

# MEASUREMENT OF STRAIN CAUSED BY RESIDUAL STRESSES IN A WELDED JOINT USING NEUTRON DIFFRACTION

## MERITEV DEFORMACIJ POVZROČENIH Z ZAOSTALIMI NAPETOSTMI V ZAVARNEM SPOJU NA OSNOVI NEVTRONOVSKEGA ODKLONA

Nenad Gubelj<sup>1</sup>, Jelena Vojvodi-Tuma<sup>2</sup>, Hans-Georg Priesmeyer<sup>3</sup>

<sup>1</sup>University of Maribor, Faculty of Mechanical Engineering Maribor, Smetanova 17, Slovenia

<sup>2</sup>Institute of Metals and Technology Ljubljana, Lepi pot 11, Slovenia

<sup>3</sup>Institute for Experimental and Advanced Physics, Christian-Albrecht-University Kiel and GKSS Research Center Geesthacht, Germany

*Prejem rokopisa - received: 1999-10-15; sprejem za objavo - accepted for publication: 1999-11-19*

The distribution and amount of residual stresses can significantly contribute to the fatigue fracture behaviour of welded joints in structures. In tensile residual stresses, which in interaction with the plane strain state, are more dangerous than residual stresses at the surface of the welded joint. If the surface of the welded joint is mechanically treated (e.g. sharpening), then significant differences between the stress states at the surface and within the volume occur. Hence, different non-destructive methods (e.g. gamma radiation, neutron diffraction) have been developed to determine strains caused by residual stresses in the volume of polycrystalline materials. However, the measurement of strains caused by residual stresses becomes difficult for large samples. In this paper the measurement procedure on a sample taken from the weld joint is presented and the effect of residual stresses on fatigue crack propagation is assessed for low and high cycle loading fatigue.

Key words: residual stresses, neutron diffraction method, fatigue crack propagation, weld joint

Porazdelitev in višina zaostalnih napetosti lahko značilno vpliva na utrujenostno obnašanje zvarnih spojev in varjene konstrukcije. Notranje zaostale napetosti so zaradi vzajemnega delovanja z ravninskimi deformacijskim stanjem bolj nevarne od zaostalnih napetosti na površini. V primeru, če je površina zvarnega spoja mehansko obdelana (npr. brušenje) se pojavijo izrazite razlike med zaostalimi napetostmi na površini in v notranjosti materiala. Zato so bile razvite različne neporokovne metode (npr. gama sevanje, nevtronska difrakcija) s katerimi se določajo deformacije, ki so posledica zaostalnih napetosti v polikristalnih materialih. Zaradi omejene penetracije neutronov (do 20mm) postaja meritev zaostalnih napetosti problematična pri večjih debelinah. V članku je predstavljen postopek meritve deformacij na iz zvarnega spoja izrezanih preizkušnic povzročeni z zaostalimi napetostmi in prikazan vpliv zaostalnih napetosti na nizko in visokociklično utrujanje.

Ključne besede: zaostale napetosti, nevtronski lom žarkov, utrujenostno trženje razpoke, zvarni spoj

## 1 INTRODUCTION

The presence of tensile residual stresses during service loading of welded structures causes the initiation of fatigue cracks from defects or flaws in welded joints. The three to four times lower stress intensity factor range  $\Delta K_h$  is caused directly by residual stresses<sup>1</sup>. Most of the publications<sup>2,3</sup> consider the effect of residual stresses in the direction of fatigue crack propagation. Nevertheless, tensile residual stresses in the thickness direction are crucial for the initiation of fatigue cracks from the defect or flaw in the welded joint. If the thickness of the welded plate increases, then the effect of residual stresses becomes more significant, because the possibility of a three axial stress state increases.

The aim of this paper is to determine strains in specimens of a weld joint caused by tensile residual stresses in the volume of polycrystalline materials, and assess the effect of residual stresses on fatigue crack propagation in low and high cycle loading fatigue.

## 2 RESIDUAL STRESSES DETERMINATION USING HIGH-RESOLUTION NEUTRON DIFFRACTION

High-resolution neutron diffraction has become a powerful method to determine strains caused by residual stresses in polycrystalline materials. The high penetration of neutrons allows the measurement of lattice plane distances by coherent Bragg scattering within the grains of polycrystalline engineering materials. Lattice plane distortions occur in the elastic regime, where the lattice plane distance has to be measured with an accuracy of  $10^{-4}$ . Neutron time-of-flight (TOF) spectroscopy has been used to determine strains caused by residual stresses. The relation between the neutron wavelength  $\lambda$ , the lattice spacing  $d$  and the scattering angle  $2\theta$  is given by the well-known Bragg formula:

$$d_{hkl} = \frac{\lambda}{2 \cdot \sin(\theta_{hkl})} \quad (1)$$

which can be written for a time-of-flight diffractometer as:

$$d_{hkl} = \frac{h}{m_n} \frac{1}{L} \frac{t_{hkl}}{2 \cdot \sin(\Theta_{hkl})} \quad (2)$$

Equation (2) shows that the neutron wave length  $\lambda$  and the neutron time-of-flight  $t$  are proportional to each other. The lattice planes are defined by their Miller indices  $hkl$ ,  $h$  is Planck's constant,  $m_n$  the neutron mass,  $L$  the neutron flight path and  $t$  the neutron flight time. With the modern crystal or time-of-flight diffractometers the scattering angles  $2\Theta_{hkl}$  or the flight times  $t_{hkl}$  can be determined to yield the required accuracy in  $d_{hkl}$ . Strains are determined as relative deviations of lattice spacings  $d_{hkl}$  (sample with residual stresses) from the equilibrium state  $d_{0hkl}$  (sample without residual stresses):

$$\epsilon_{hkl} = \frac{d_{hkl} - d_{0hkl}}{d_{0hkl}} \quad (3)$$

Strains are then converted into stresses using the generalized Hooke's law:

$$\sigma_{ij} = C_{ijkl} \epsilon_{kl} \quad (4)$$

where  $C_{ijkl}$  are the stiffness coefficients of the material. This calculation has not only to take into account the dependence of the crystal's elastic properties on orientation, but also models of intergranular force coupling as well as the influences of preferred orientation (texture), microstructure and plastic anisotropy<sup>4</sup>. As can be seen from eq. (3), the incorrect determination of lattice spacings for the stress-free case  $d_{0hkl}$  will cause systematic errors for the stressed state.

### 3 MEASUREMENT PROCEDURE

The measurements were carried out at the 5MW research reactor FRG-I of the GKSS Research Center using a (three point bend) fracture toughness specimen machined out of a welded plate. The specimen without residual stresses was stress relieved at 530°C for 2 hours. The GKSS Fourier correlation spectrometer FSS (Fourier-Strain-Spectrometer), operating in the reverse

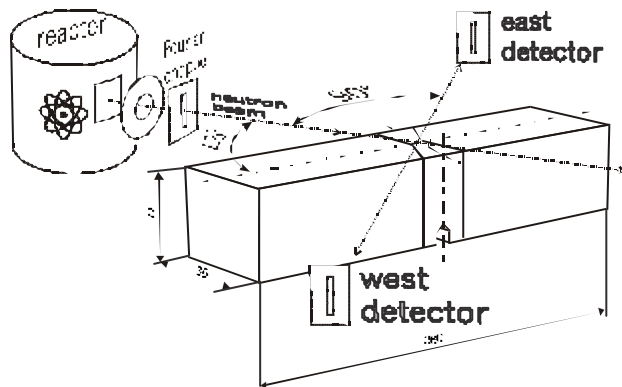

**Figure 1:** Schematic view of measuring reflections intensity of neutrons on specimen

**Slika 1:** Shematski prikaz meritve gostote odbojev neutronov na preizku{ancu

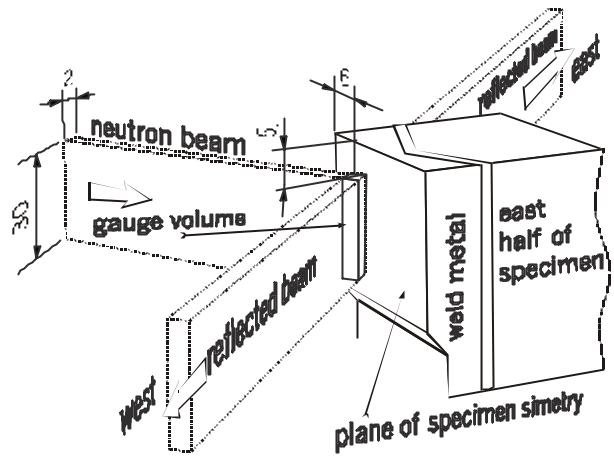

**Figure 2:** Position of gauge volume (2x2x30 mm) in the welded joint  
**Slika 2:** Polo{aj obsevanega volumna (2x2x30 mm) v zavarjenem spoju

time-of-flight mode, has been optimised to measure strains in engineering components<sup>5</sup>. The neutron flux at the sample position was  $3 \times 10^6$  n/cm<sup>2</sup>sec. Scattered neutrons were detected by a bank of 16 Lithium-6 loaded glass scintillators in time-focussing geometry. The nominal resolution was  $3 \times 10^3$ .

**Figure 1** shows a schematic diagram of the time-of-flight diffractometer FSS. The measurement was

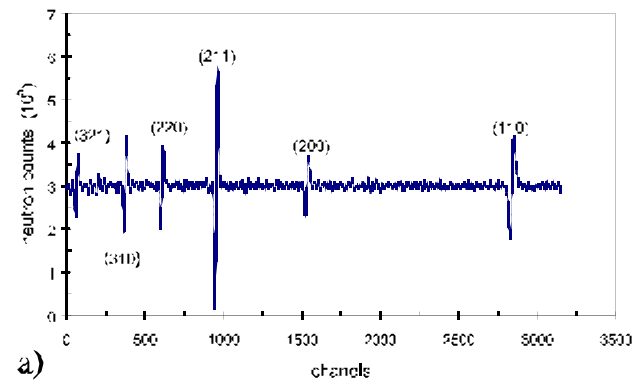

a)

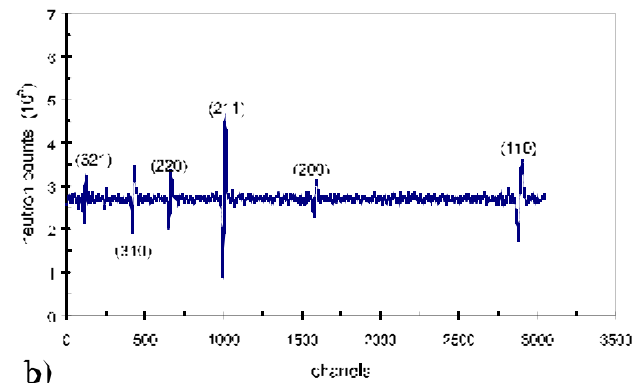

b)

**Figure 3:** Complete time-of-flight diffraction pattern measured at a) east and b) west detector

**Slika 3:** Difrakcijski vzorec izmerjen v celotnem -asu prileta neutronov na a) vzhodnem in b) zahodnem detektorju

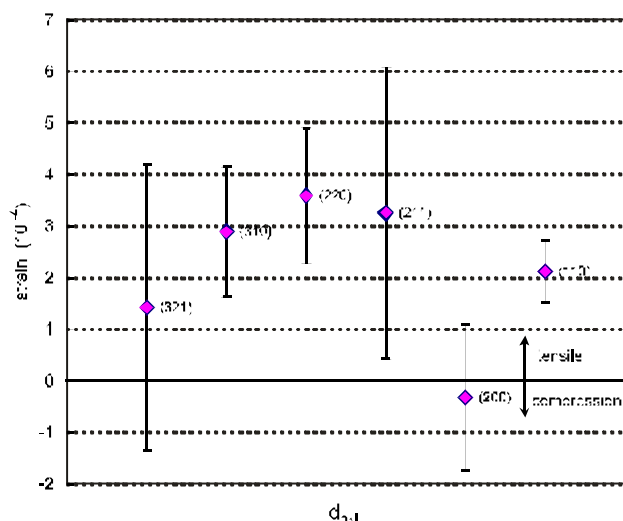

**Figure 4:** Distribution of strains in lattice planes of the ferritic phase (bcc)

**Slika 4:** Porazdelitev deformacij v kristalografskih ravninah za feritno fazo (bcc)

performed using a gauge volume of  $120 \text{ mm}^3$  ( $2 \times 2 \times 30 \text{ mm}$ ). The basic assumption was that the strain in the weld pass direction (30 mm) does not significantly change for a certain point. It is assumed that the peak of the tensile residual stresses is 6 mm away from the surface of the specimen, as shown in **Fig. 2**. The highest tensile stresses are expected in this region.

The time-of-flight (TOF) neutron diffraction method gives the average lattice distance for the whole measured volume. Using the TOF method it is possible to determine strains for many different lattice planes in the spectrum. As shown in the spectrum, see **Fig. 3**, several reflections were measured simultaneously, so it is useful to employ more than one Bragg peak for the strain determination. Each Bragg peak belongs to one of the lattice planes. The full spectrum covers the (110), (200), (211), (220), (310) and (321) reflections of the ferritic cubic-bcc structure.

#### 4 DISCUSSION

The set of equations was solved with respect to the strain components. The principal strains caused by residual stresses are shown in **Fig. 4**. The deviations in measured strains and statistical errors are large. The large statistical error is a consequence of measuring in a large volume. In the large volume the strains in a particular lattice plane are summed as tensile and compressive contributions in the same direction in the gauge volume. The neutron penetration in ferritic steels is limited but the measurement requires a minimum number of neutrons in the beam. Therefore, if the thickness of a specimen increases then the gauge volume should be larger, but then the problem of average stresses arises in the observed volume. A stronger neutron beam is not possible because the measuring is

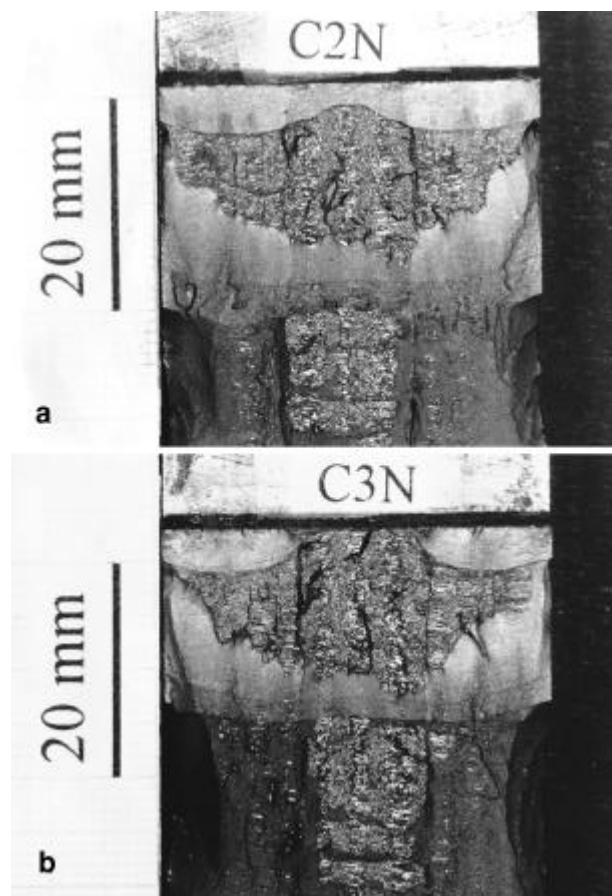

**Figure 5:** Obtained fatigue crack shapes through-the-thickness of specimen,  $a/W=0.5$ ;  $W=72 \text{ mm}$  using a) low and b) high cycling fatigue under the effect of residual stresses

**Slika 5:** Dobljene oblike fronte utrujenostne razpoke skozi debelino preizku{anca  $a/W=0.5$ ;  $W=72 \text{ mm}$  z uporabo a) nizko in b) visoko cikličnega utrujanja pod vplivom zaostalnih napetosti

limited. The strain distribution of the (200) plane in the sample is significantly lower than the other investigated lattice planes. The lattice plane (200) is in the softest direction<sup>6</sup>. The greatest Young's modulus is the consequence of the crystals grain orientation due to the direction of the neutron beam. The other lattice planes show significant tensile strain. The maximum strain of the examined lattice plane (211) is  $3-4 \times 10^{-4}$ .

The effect of tensile residual stresses on fatigue propagation was estimated using low and high cycle loading. Low and high cycle fatigue were performed on a load level of  $60\%F_y$ -yield load (amplitude load  $\Delta F = F_{\max} - F_{\min} = 18\%F_y$ ) and on a load level of  $20\%F_y$  (amplitude load  $\Delta F = F_{\max} - F_{\min} = 18\%F_y$ ), respectively. The obtained fatigue crack shapes for both cases are shown in **Fig. 5 a) and b)** respectively.

Residual stresses are present in the specimen cut out of the welded joints. For high cycling fatigue the crack shape shows a significant effect of the residual stresses on fatigue pre-cracking only in the tensile residual stress region, where tensile strain was measured. In the case of low cycling fatigue the crack shape shows a decrease of

the effect of residual stresses. However, the effect of tensile residual stresses near the surface and compressive residual stresses in the mid-thickness is still evident. Therefore, the effect of residual stresses is significant during the initiation of fatigue crack propagation.

## 5 CONCLUSION

The strains caused by residual stresses are determined on the basis of high neutron diffraction measurements. The interior strains in specified lattice planes are calculated. Except polycrystalline structure and chemical composition of microstructures, the accuracy of measurements of lattice distance depend on the thickness of the specimen. Therefore, in the case of large specimens it is necessary to use large sample volumes for neutron diffraction, if the intensity of the neutron beam is limited. For a large gauge volume the measurement integrates over all lattice planes. Hence, using a large gauge volume causes broadening of a Bragg reflection, if strain gradients are present.

The performed measurements show the largest residual stresses for crystallographic lattice planes (220), (221) and (321). Residual stresses in these planes support the initiation of fatigue crack propagation at high cycling levels. The tensile residual stresses contribute to a higher susceptibility of welded joints on fatigue

cracking. The result of this event is a lower threshold of the stress intensity factor range  $\Delta K_{th}$ . Therefore, the often unconsidered effect of residual stresses through the thickness of a welded joint presents a damage parameter of the welded structure.

## 6 REFERENCES

- <sup>1</sup> Japan Welding Engineering Society Standard: "Method of Assessment for Flaws Welded Joints with Respect to Brittle Fracture and Fatigue Crack Growth, WES 2805-1997"
- <sup>2</sup> Glinka G.: "Effect of Residual Stresses on Fatigue Crack Growth in Steel Weldments Under Constant and Variable Amplitude Loads", American Society for testing and Materials STP 677, C.W. Smith, Ed. **1979**, 198-214
- <sup>3</sup> Chang J.B., Chiu S.T., Goodemberger D.L.: "Residual Stress Effects on Safe-Life of Welded Structures", *Proceeding of 9<sup>th</sup> Int. Conf. on Fracture*, Sydney, Australia 1, **1997**, 547-554
- <sup>4</sup> Mohr A., Priesmeyer H.-G.: "Experimental Correlation Between the Elemental Composition and the Lattice Dimensions in Alloys, Using AlCu as a Model Substance", *Int. Conf. Neutrons and Their Applications*, Crete, Greece, **1994**, SPIE Vol. 2339, 350-355
- <sup>5</sup> Priesmeyer H.- G.: "Reverse time-of-flight Fourier Technique for Strain Measurements", *Proceedings NATO ARW Oxford*, Kluwer Dodrecht, **1992**, 329-334
- <sup>6</sup> Schröder J., Priesmeyer H.- G.: "Residual Stress measurements in an Inertia Welded Sample by Means of Different Neutron Diffraction Techniques", *Proceedings of 3<sup>rd</sup> Int. Conf. about Residual stresses*, 253-258