

DEVICE FOR THE MANUFACTURING OF OVENS BY RESISTANCE SEAM WELDING

NAPRAVA ZA IZDELOVANJE PEČIC Z UPOROVNIM KOLUTNIM VARJENJEM

Zdravko Praunseis[✉], Seudin Softić¹

Keywords: eresistance welding, seam welding, oven line FS16, automation line

Abstract

In the industries that simultaneously require large productivity and high reliability, it is necessary to invest much time in different studies and to choose the right equipment for the desired product. While we were designing an automated line for the production of FS16 ovens, we encountered a variety of challenges, because we used equipment that is mostly unknown in our environment. In this article, the basic device for resistance seam welding is described. Various forms of the welds are also described.

The device itself will have a huge role in the operation of the line; therefore, it was very precisely constructed and designed.

Povzetek

V industrijah, kjer se zahteva velika produktivnost in hkrati velika zanesljivost izdelkov, je treba vložiti veliko časa v razne študije in izbrati ustrezno opremo za konstrukcijo ciljnega izdelka. Pri projektiranju avtomatske linije za proizvodnjo pečice FS16 smo se srečali z najrazličnejšimi izzivi, saj smo uporabili opremo, ki je v našem okolju še neznana. V članku je opisana naprava za uporovno kolutno varjenje in različne oblike zvarov.

Naprava ima pomembno vlogo pri delovanju delovne linije, zato je natančno oblikovana in konstruirana.

[✉] Corresponding author: Zdravko Praunseis, Faculty of Energy Technology, University of Maribor, Tel.: +386 70 286 719, Mailing address: Hočevarjev trg 1, Krško, Slovenia, E-mail address: zdravko.praunseis@um.si

¹ Gorenje d.d., Partizanska 12, Velenje, Slovenia

1 INTRODUCTION

Therefore, it is necessary to make hypotheses before we start designing, and attempt to confirm or reject them. The purpose of this master's thesis is also to generally demonstrate the welding of steel constructions and the factors that are important for quality welded joint. The theoretical background knowledge is then demonstrated on the seam welding device itself. For the quality design of the device, a great deal of various knowledge is necessary. The main factors to design and realise welded joints are: characteristics of the steel, sort of loads, different varieties of welding, sort of adding materials, etc. Appropriate choice of equipment and welding procedure is a major factor. Regular maintenance is necessary to ensure a long functioning of the device without problems. The biggest focus is on cooling of the electrodes, the control unit, and the transformer. Because of the very large current that flows through those elements, the thermal burdens are enormous. They must be surrounded with a cooling liquid. Care must be taken not to produce any condensate in those elements.

2 EXPERIMENT AND RESULTS

Welding is implemented on two joints, where the plates of U-circumference and ceiling overlap by a few millimetres, [6].

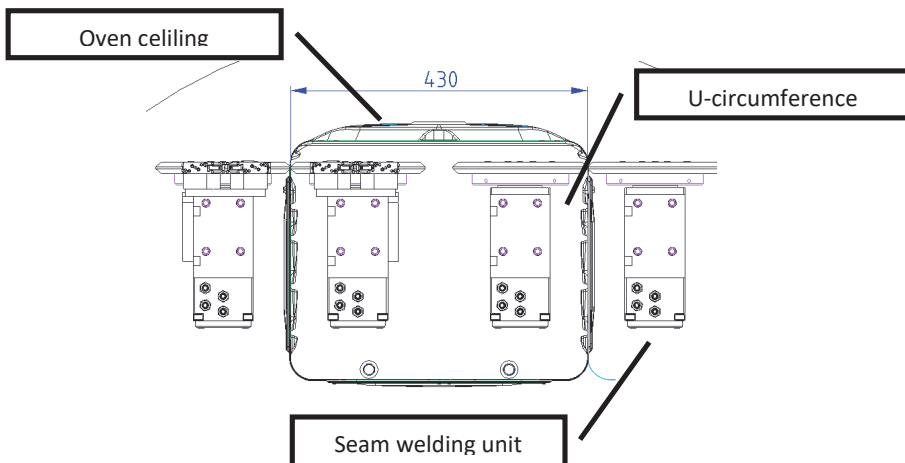

Figure 1: Welding sketch

Ceilings are taken from a specially modified transporter with a robot arm with a pneumatic gripper, and they are additionally positioned on a special unit in X,Y directions.

Ceilings are then delivered to a rotatable unit, where they are positioned on lateral glands and vacuum clamped. The U-circumference is loaded with a line manipulator (two-dimensional manipulator with several sequential grippers). The robot transfers the U-circumferences with a pneumatic gripper from a U-bending station to a line manipulator entry place, [4].

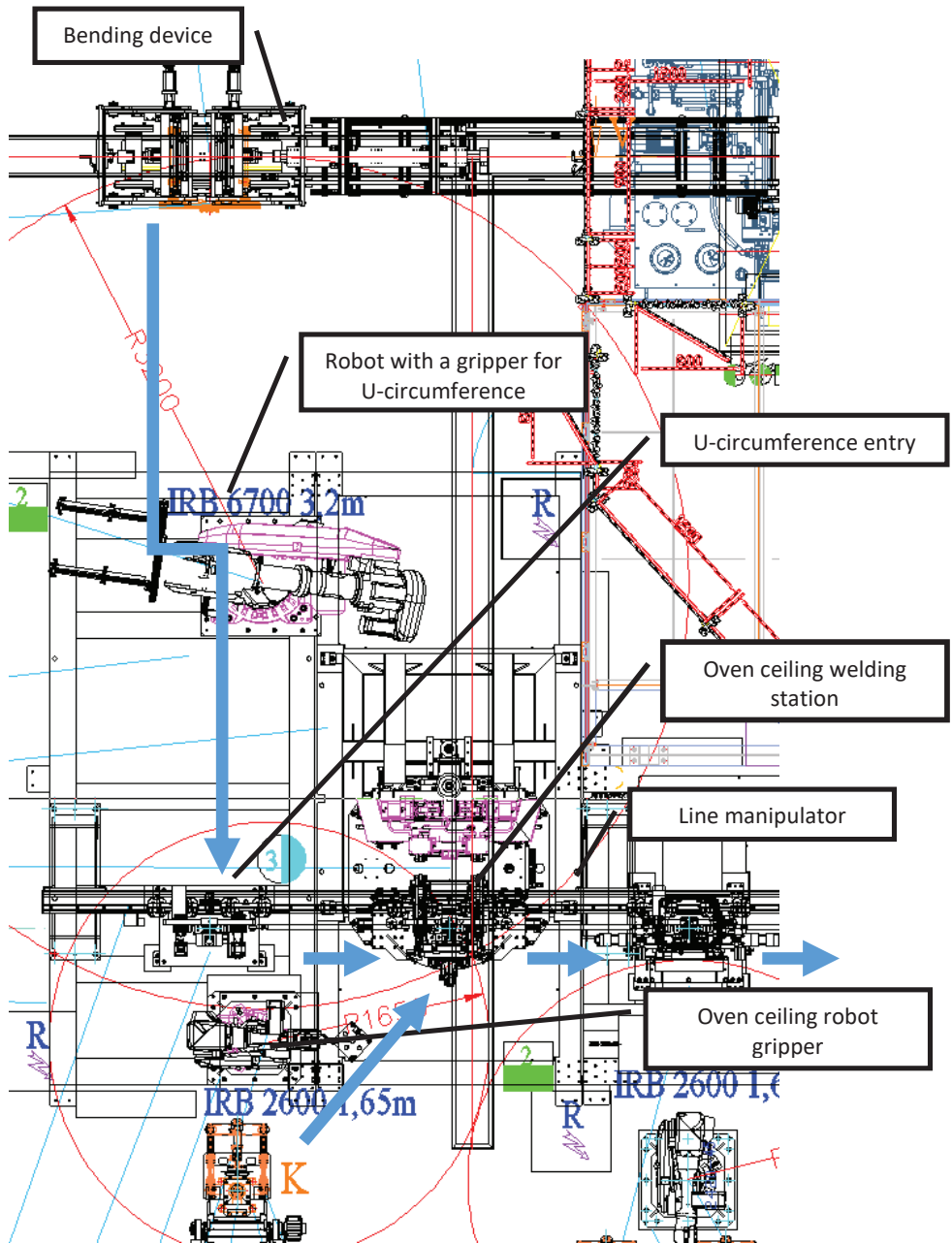

Figure 2: Station's ground plan

The line consists of four main connecting segments:

- U-circumference formation,
- composing and welding of the oven,
- manufacturing the oven's back end,
- transport system.

There is an unwinding station with a lifting unit for a sheet reel at the beginning of the line. After the straightening and cutting station is the station for storing cut sheets, which ensures smooth line functioning during the sheet reel exchanges.

After that, there is a station for the lubrication of cut sheets and a serving unit that transfers the sheets further in the presses, which contains hole-cutting tools, and after that on a conveyor. The U-bending station is at the end.

The robot is transmitting the U-circumference with a gripper on a composition and welding part of the line. The main feature of that part of the line is a line manipulator with 14 grippers, which are transferring ovens from one station to the other at the same time. In this part of the line, there are stations for welding and shaping different oven assembly parts. At the end of that part of the line, the carriers for enamelling are being welded. At the very end of the welding line, there is a unit for the automatic assembly and welding of the oven and front end, where the robot with a pneumatic gripper is transferring the front ends from a line storage container. A set of stations for manufacturing of the back ends serves for production of many variants of cut back ends and shapes. Back ends are delivered from line storage transporters and a robot with a pneumatic gripper on to a welding station. Custom-designed welding units are spot welding the housing of the oven with front ends, [4].

The station for ceiling welding has the following key features:

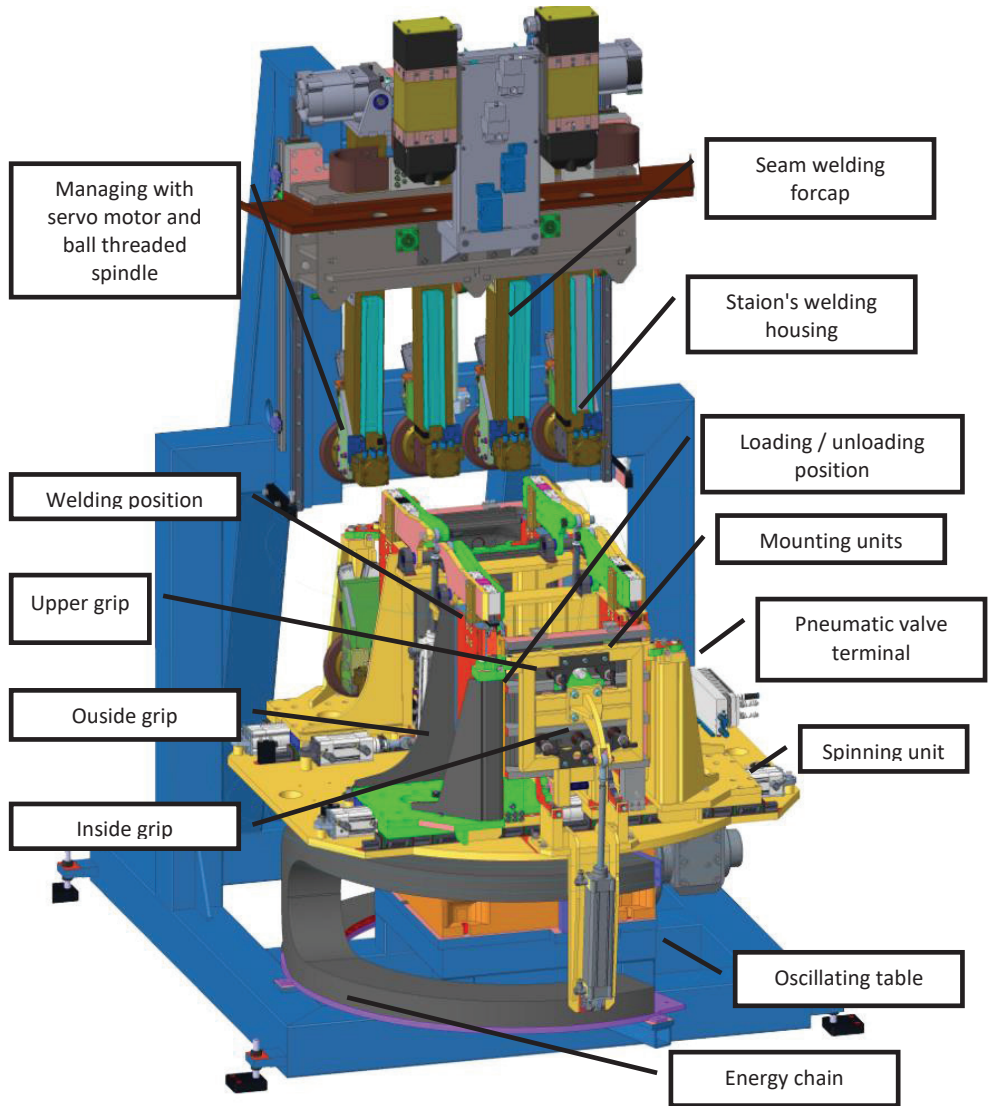

Figure 3: Final station for oven ceiling welding

Because of short deadlines, designing this kind of station is a process in which it is necessary to accept the decisions that affects the reliability, power consumption, welding quality, dimensions, appearance and price. All these criteria must be optimally coordinated for the success of a project. We can highlight two arguments among all the others.

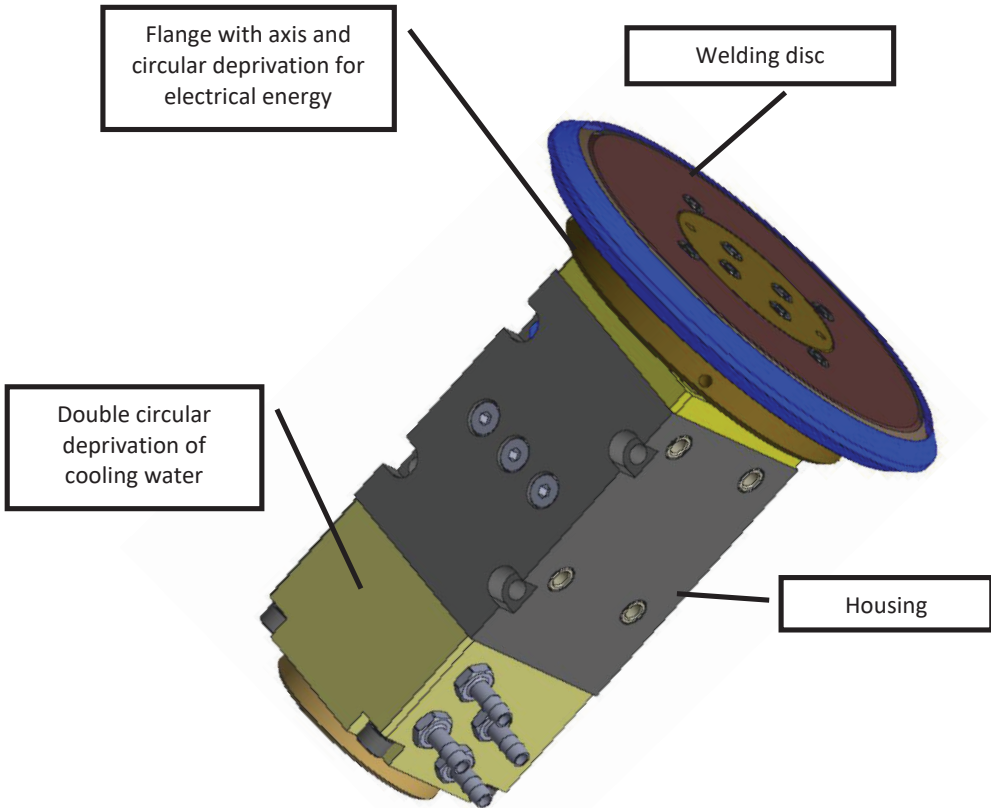

Figure 4: Seam welding unit

The transition of electrical energy from the frame to rotary axis is executed with a special space that is sealed and contains a conducting material. Previously, mercury was used, but it is currently forbidden because of environmental standards. Because of welding and the enormous amount of conducting electrical energy, conductor heating occurs. Extraction of that heat is ensured with the supply of cooling water. Two units for seam welding are installed on the seam welding forceps, [6].

Forceps for seam welding are vital at that station, among the correct mounting of the sheets. Actuating valves ensure the force needed for welding. The force is set automatically through the

welding control unit according to the welding parameters and current welding conditions. In Figure 5, the principal forceps elements are shown.

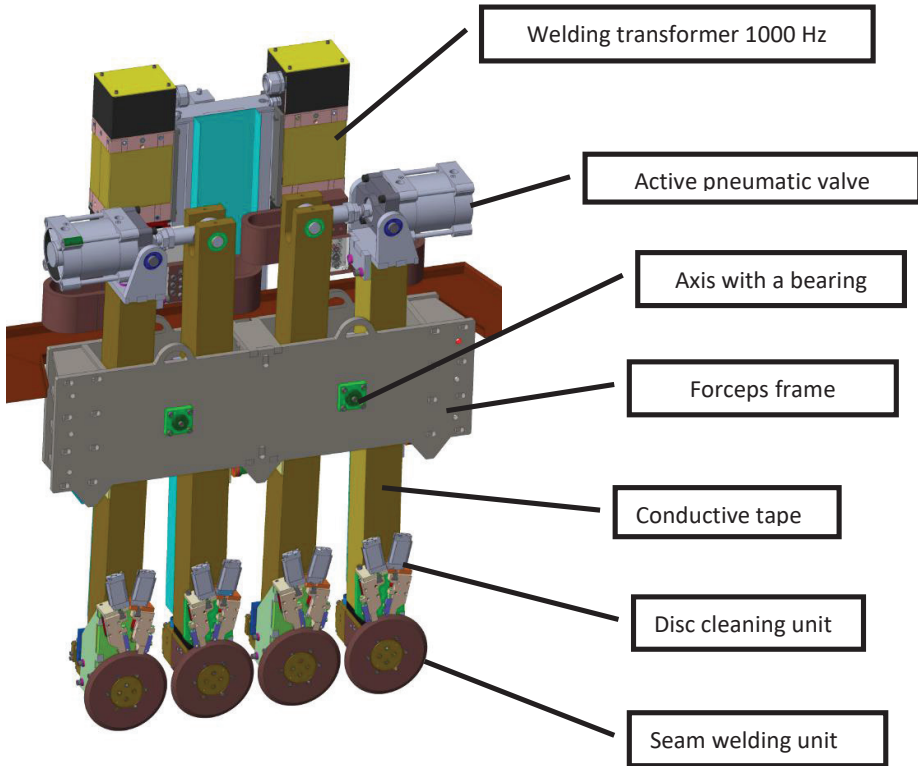

Figure 5: Seam welding forceps

Through tests that were made at different line and welding components, it was concluded that we need a principle of two seam welders for each welded joint to ensure quality welding. The previous version of the station (2008) contained a seam on a straight electrode. The principle worked, but it no longer ensures sufficient quality for new demands; the sheet on the inner side was not adequately merged to the ceiling; therefore, an edge was visible. Implementing seam forceps improved the quality of the final product.

The cooling is determined according to the type of weld, number of welds per minute, the size of the current, and the cross-section of secondary conductors. Direct cooling of the tip of the electrode would be ideal, as shown on Figure 6. That way, a direct extraction of the heat is ensured. The life span is extended, and the welding lenses and joints are of higher quality, [4].

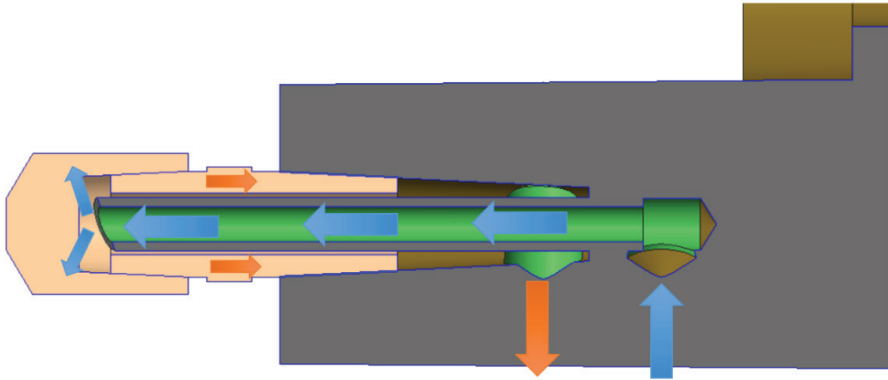
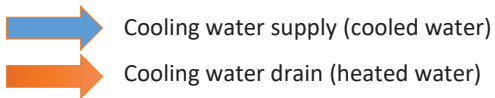

Figure 6: Supply and drain of the cooling water for electrodes

Legend:



Without the cooling of the electrodes, they would eventually reach material-melting temperature. As they are heat strengthened materials, all good mechanical characteristics that they got during the heat treatment would be lost. If the electrodes are extremely heated, so-called bonding of material on the electrode occurs, and working geometry is corrupted, which is followed by large amounts of melted metal spraying at the next weld. Much improper cooling would take place.

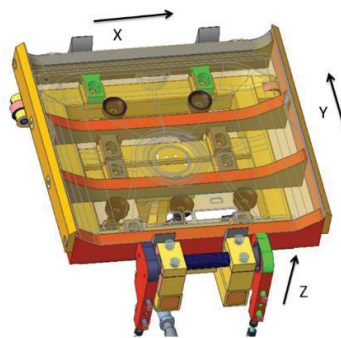

Figure 7: Ceiling placement in X,Y directions

Up and down, the ceiling sheets are placed separately in Z directions (Figure 8) so as to prevent dimension inaccuracy.

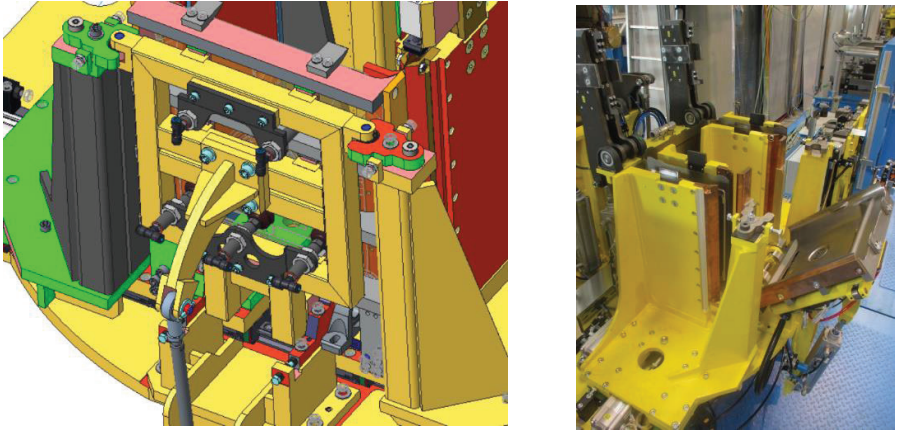

Figure 8: Ceiling placement in Z directions

The U-circumference and the oven ceiling must be correctly positioned in a final stage of disposal. When they are in position and mounted, the device is ready for the seam welding.

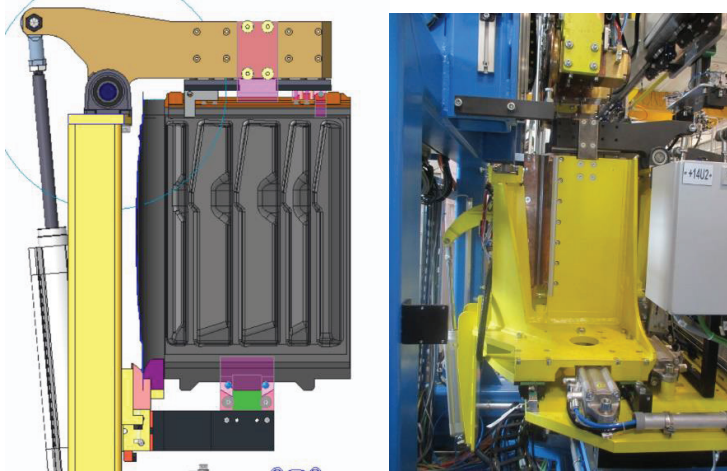

Figure 9: U-circumference and the oven ceiling are ready for seam welding

At the starting point the seams are in the top position and spaced from each other. The down move is executed by a servo motor, [4].

The first position is 10 mm above the oven, where a weld joint is made. We made a joint to prevent a deviation of the U-circumference and the ceiling of the oven.

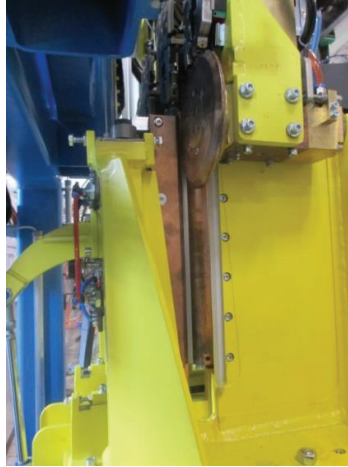

Figure 10: The position of weld joint that prevents U-circumference and ceiling deviation

When we are done with a weld joint, the welding disk performs a down move to a position 2 mm above the bottom edge of the oven. It is very important that we move the disks as close to the edge of the oven as we can, so that we prevent the deviation of the U-circumference and the ceiling of the oven.

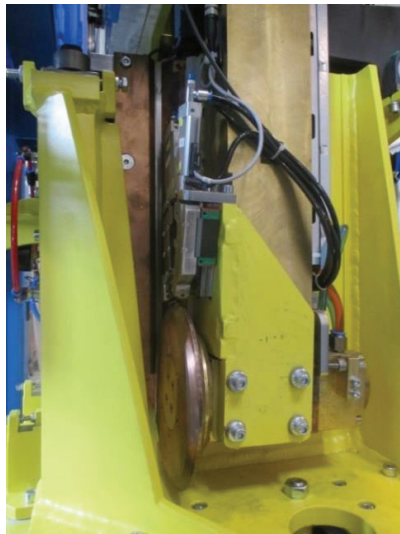

Figure 11: Bottom position of seam weld

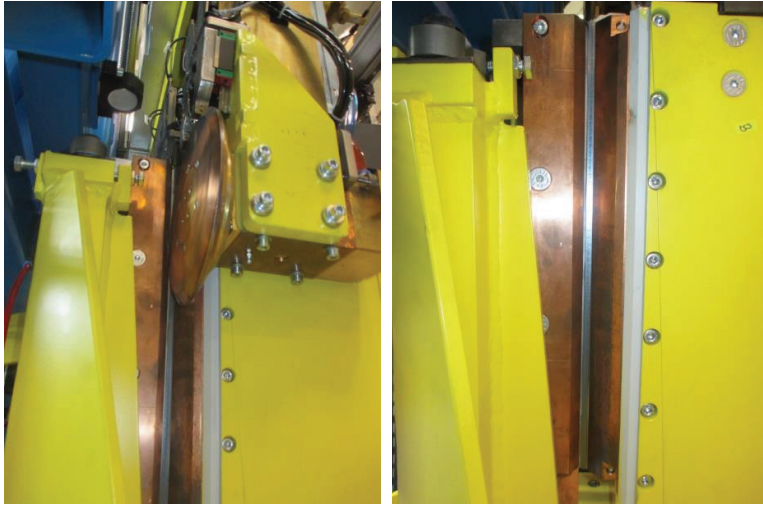

Figure 12: Upper position of seam weld



Figure 13: An example for welded U-circumference and front end.

The BOS 6000 program is specially adapted to manage all BOSCH controllers. The program allows us to adapt the blocks and welding programs. In each block or program, we can set the required parameters, such as time of prepressing, pressing, welding, cooling, etc. Among all time

parameters, we can also set the type of welding (point, seam) and the pressure of the seams to the welders. Those were the most frequent parameters used in this project. Of course, many other parameters and functions can also be set.

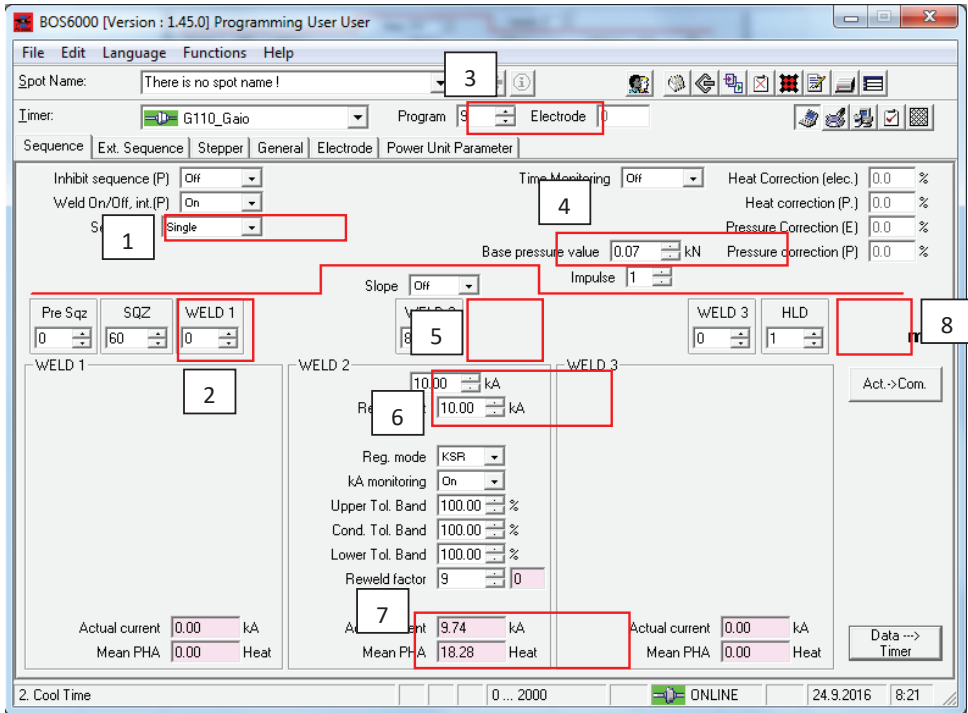
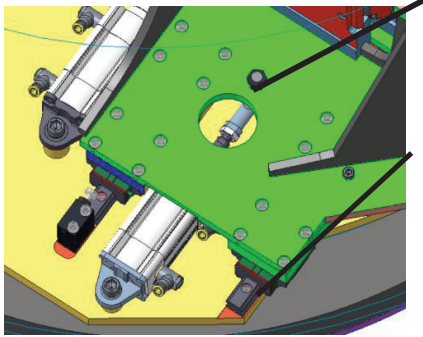

Figure 14: Spot-welding parameters

This station is highly productive, as are all other stations, which is why they are all crucial for the production of the line. In case of an error, the mistake must be easily and quickly repaired.

A permanent dynamic test is ensured for most of the elements of the station. The machines are designed so as to predict the places of installations and the easy ways to replace spare parts, [4-6].

Example of maintenance:



Construction of suitable holes for easier setting

Installation of stripper plates, that protects the trolley from welding syringes

Figure 15: Linear feed composition

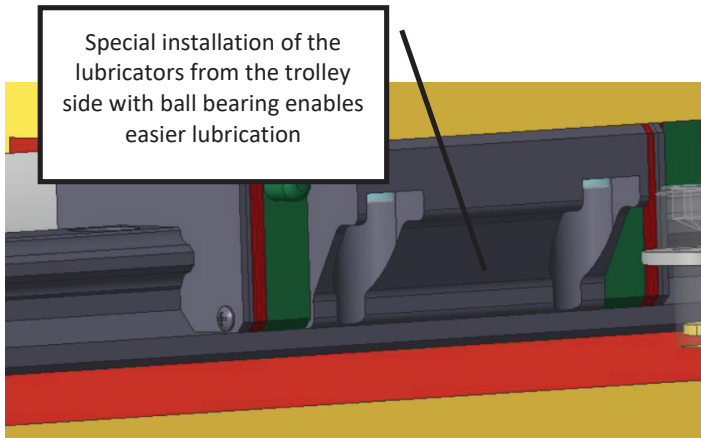

Special installation of the lubricators from the trolley side with ball bearing enables easier lubrication

Figure 16: Mounting of side lubricating nipple on to a trolley

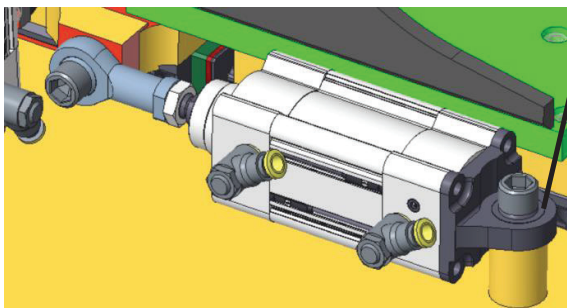

Flexible bearing mount of two-way active valves ensures their long life expectancy

Figure 17: Mounting of active pneumatic valve

3 CONCLUSION

Designing or constructing seam-welding devices have been developing dramatically lately. The designers have a huge advantage in the possibility to work in sophisticated and advanced software, so they can imagine how to improve the device and make it more efficient. In this master's thesis, I concentrated on the process of welding, which are modified and improved through time. We learn about new ways of welding metal and other materials; accordingly, we must construct a welding device. For the purposes of production in the company Gorenje Mora in the Czech Republic, we constructed a device and placed on an automated line, so as to exclude the human factor and reduce the chance of an error; the merging also became much faster. The device needs about 10 seconds to complete a weld, while a person would spend much more time for the same work. We encountered many mechanical and software problems at the start up. To have a quality weld, it is crucial to know the material that is being worked on. We have learned that the cooling of the heating components is also very important. Two ways were available: air or water cooling. Based on good experiences, we decided to cool the components with water. The investments in this project are enormous, but the company's vision is to automate the production as much as possible. Any parameter changes can be implemented through a control panel on a control desk, which is placed near a device. The seam welding discs are being used up over time, therefore the parameters as disc pressure or secondary current on the transformer must also be adjusted.

References

- [1] **S. Pešan:** *Metodika konstruiranja: univerzitetni učbenik – Maribor*, Fakulteta za strojništvo, 2005
- [2] **B. Kraut:** *Krautov strojniški priručnik*, 14. Slovenska izdaja / izdajo pripravila Jože Puhar, Jože Stropnik. Ljubljana: Littera picta, 2003
- [3] **Z. Praunseis:** *Energetski inženiring, Zapiski predavanj*, Fakulteta za energetiko, 2015
- [4] **S. Softić:** *Welding machine for cavity FS16 with resistance spot welding method, Master Theses in progress*, Faculty of energy technology, 2016
- [5] **B. Hudej:** *Koncipiranje in snovanje postaje za varjenje stropa pečice: diplomsko delo – Maribor*, Fakulteta za strojništvo, 2016
- [6] **Z. Praunseis:** *Točkovno uporovno varjenje nerjavnega bobna pralnega stroja, tehniško poročilo o raziskavi*, Fakulteta za strojništvo, 2003