

Gear Unit Housing Effect on the Noise Generation Caused by Gear Teeth Impacts

Milosav Ognjanović^{1,*} – Snežana Ćirić Kostić²

¹ University of Belgrade, Faculty of Mechanical Engineering, Serbia

² University of Kragujevac, Faculty of Mechanical Engineering, Serbia

The basic hypothesis of the paper is that machine part surfaces are membranes that divide inner and outer space, receive disturbance power from inner space and emit it to the surroundings. Additionally, machine systems operation causes numerous disturbances such as collisions, sliding, rolling, etc. Gear drives are a very interesting case for analysis of teeth impacts, which cause restorable free vibrations and spreading of disturbance power through elastic structure. The gear unit housing has a dominant role in the transformation of disturbance power and modulation of the sound emitted to the surroundings. This is an important detail for monitoring and diagnostics by emitted noise measurements. By combination of theoretical, numerical and experimental analyses, using a classical gear drive unit (reducer), this article explains the process of spreading disturbance power through the elastic structure, especially the role of the gear unit housing. Its role in the noise frequency spectrum modulation is determined by modal sensitivity to disturbances and noise isolation ability of the housing. The analysis of modal behavior of the housing and its modal shape excitation presents the main content of the paper.

Keywords: gears, noise, vibration, modal analysis

0 INTRODUCTION

The process of gear unit noise generation is complex and it is usually studied through investigations of three sub-processes: generation of disturbance power by the action of gear unit components (gears and bearings), spreading of disturbances through the gear unit structure and disturbance power emission through vibrations and noise of the gear unit. Identification of dominant causes of noise at the place where disturbances are generated was extensively studied and considered in numerous papers. Vexel and Ajmi [1] introduced their theoretical approach to the modeling of pinion-gear excitation valid for three-dimensional models of single-stage geared transmissions. Tuma [2] studied the problem of the simple gear set transmission error measurement. On the other hand, De la Cruz [3] described a model of impact dynamics of meshing gear teeth-pairs under medium to heavy loads in the presence of backlash. The model incorporates the classical Hertzian impact, governed by instantaneous geometry of the contact and the prevailing kinematics of contiguous surfaces for pairs of helical teeth. Houser and Harianto [4] considered bearing forces that are the result of mesh forces analyzing the influence of gear meshing impact forces, effective transmission error forces, shuttling forces, friction forces and forces due to the entrapment of air and lubricants. In paper [5], Houser, Harianto and Ueda presented a procedure of selection and optimization of gear profile with respect to noise reduction. Barto et al. [6] analyzed the phenomenon of rattle noise caused by the fluctuation of the engine torque (acyclic

excitation) which, under special conditions, can cause multiple impacts inside the gearbox. Thodossiadis and Rahnejat with collaborators have extensively investigated vibrations at the source of excitation of geared systems. In paper [7], they analyzed nonlinear dynamic response of a gear pair system with periodic stiffness characteristics and backlash. Later, in paper [8], they used theoretical and experimental methods to analyze the impact-induced vibrations in vehicular driveline systems. The results showed high-frequency contributions in driveline vibrational response of certain structural modes of driveshaft pieces, which are induced by remote impact of meshing transmission teeth through backlash. Also, Theodossiadis et al. in [9] and [10] introduced their approach for understanding the interactions between the transmission gears during engine idle conditions by taking into account the effect of lubrication. They showed that the lubricant film under these conditions behaves like a nonlinear spring damper, which significantly affects the response of idler gears during the meshing cycle. Kartik and Houser [11] analyzed the effects of shaft dynamics on gear vibration and noise excitations. A method for suppression of gear pair vibration by active shaft control is developed in [12] by Guan et al. The effects of bearing stiffness on critical rotational speeds of gearboxes are analyzed by Rigaud et al. in [13].

Several papers present the possibilities of numerical prediction of sound pressure level. Houser et al. compared numerical predictions for a simple gearbox to experimentally measured data [14]. Inoue [15] proposed an optimum design method,

*Corr. Author's Address: University of Belgrade, Faculty of Mechanical Engineering, Kraljice Marije 16, 11000 Belgrade, Serbia, mogjanovic@mas.bg.ac.rs

which minimizes the vibration energy, for a thin-plate structure, and applied it to the gearbox housing design for low vibrations and noise. In [16], Abbas et al. developed an FEM based model with the goal to estimate acoustic radiation of a simplified gearbox internally excited by gear mesh stiffness fluctuation. Tuma in paper [17] reviews the research work on reducing truck gearbox noise considering various relevant factors, from the source of noise to housing design. He concluded that a low noise gearbox requires sufficiently rigid housing, shafts and gears, tooth surface modifications and application of HRC (High Contact Ratio) gears.

The main goal of this paper is to present the investigation of the influence of the gear unit housing on vibrations and acoustic emission of a gear unit. Disturbances caused by teeth impacts are the strongest during the initial contact of a teeth pair, and they are periodically repeated. That is why these disturbances are selected for the definition of disturbance power and analysis of spreading the disturbance power through the gear unit structure. A casted housing of a general use gearbox is selected as the object of the research, but the obtained results are of a general nature and are applicable to all mechanical systems with a periodic generation of disturbances.

1 GEAR DISTURBANCES CAUSED BY TEETH IMPACTS

Gear teeth meshing is accompanied by different kinds of gear teeth impacts. In spur gears, teeth impact is the most intense during addendum collision. The impact is dependent on elastic deformations of the gear teeth, but deviations of dimensions and the shape of teeth profiles can intensify the impact force. The teeth deformations are proportional to the teeth load and inversely proportional to teeth stiffness. The spur gear teeth contact begins along the whole width of the gear, having the maximal stiffness c' at the beginning of the impact. On the other hand, in helical gears, teeth meshing starts with the contact at one end of the teeth and gradually extends along the contact path. Therefore, the initial stiffness c' and the initial impact force of helical gears are considerably smaller in comparison to spur gears.

The impact deformation of spur gears changes the initial contact point from position A to position A', which is ahead of point A (Fig. 1). The contact of the teeth pair starts with an intensive addendum impact, with the collision force F_c . The collision speed v_c is proportional to the deformation of the teeth, speed of rotation n and gear design parameters. After each collision of teeth, natural vibrations of meshed gears

arise. The natural frequency is proportional to the square root of average stiffness of meshed teeth c_y (according to DIN 3990 and ISO 6336) and inversely proportional to the equivalent mass m_e :

$$F_c = v_c \sqrt{c' m_e}, \quad f_n = \frac{1}{2\pi} \sqrt{\frac{c_y}{m_e}}, \quad (1)$$

$$m_e = \frac{m_{t1} m_{t2}}{m_{t1} + m_{t2}}, \quad m_{t1} = \frac{J_1}{r_{b1}^2}, \quad m_{t2} = \frac{J_2}{r_{b2}^2}.$$

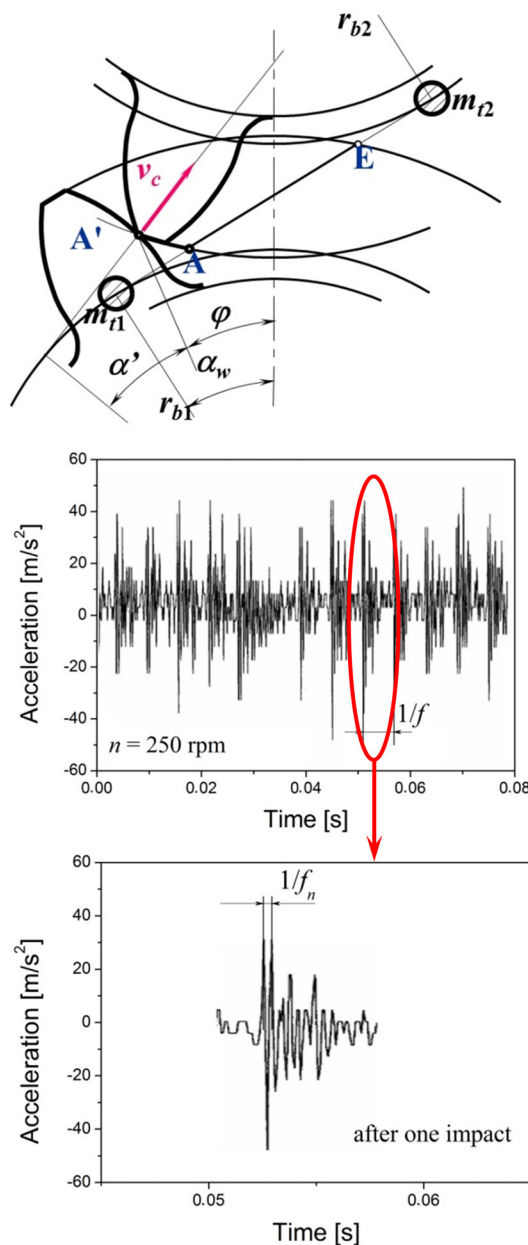

Fig. 1. Restorable gear vibrations caused by successive impacts repetition

For the purpose of natural frequency calculation, the model of rotating masses is transformed into the model of harmonic oscillator. Moments of inertia of the rotating masses J_1 and J_2 are transformed to the concentrated masses along the direction of the teeth contact line. The radii of the basic circle of the gear pair are $r_{b1} = (m z_1 / 2) \cos\alpha$ and $r_{b2} = (m z_2 / 2) \cos\alpha$, where the profile angle is $\alpha = 20^\circ$, m represents the gear module, and z_1 and z_2 are the corresponding gear teeth numbers.

Gear vibrations are non-linear because of the variation of stiffness of teeth in mesh. The variation is related to the profile of the contact position and to the number of teeth in mesh. For the purpose of practical application, the gear calculation is linearized by introducing average stiffness of teeth in mesh c_y , as described in standards DIN 3990 and ISO 6336. As further analysis is directed at the effects of gear housing, the nonlinearity of vibrations has no significant effects on the obtained results.

Teeth collision produces free damped vibrations of gear masses with the natural frequency f_n . These free vibrations are very quickly damped (Fig. 1), but the subsequent collisions restore them again. Teeth collisions repeat with each tooth entering the mesh, i.e. with the disturbance frequency (frequency

of forced vibrations) $f = nz / 60$ (n is the number of gear revolutions per minute, and z the number of gear teeth). Each subsequent collision restores vibrations, and a specific type of restorable free vibrations arises.

Fig. 1 shows time variation of acceleration of a gear during restorable free vibration in the case of small speed of gear rotation. With the increase of the rotational speed, the frequency of teeth collision f increases and resonance arises when frequency f becomes equal to the natural frequency f_n . In the supercritical range, the frequencies of teeth collisions are higher than the natural frequency of the gears, $f > f_n$. Vibrations are realized by their natural frequency, but due to the increased intensity of teeth collisions, the level of free vibrations with the frequency f_n is higher [18].

2 TRANSMISSION OF DISTURBANCES THROUGH THE GEAR UNIT STRUCTURE

Disturbances (impacts, rolling, sliding, etc.) produce micro elastic deformations which absorb disturbance power inside machine parts. This process presents a special subject for analysis. The absorbed disturbance power is transmitted through the gearbox parts in the form of elastic waves. One part of this power

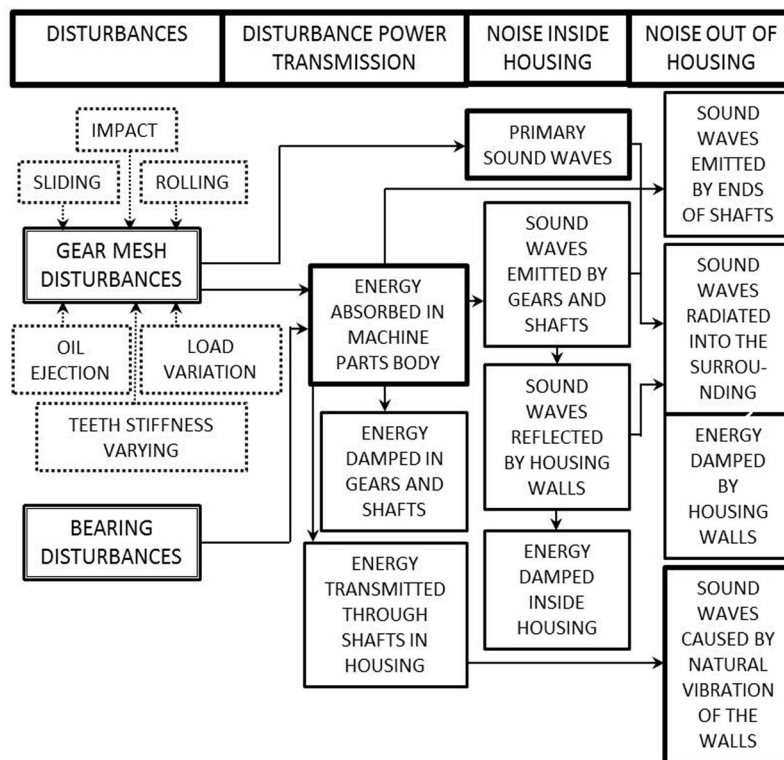

Fig. 2. General structure of disturbance energy transformation

is attenuated inside the machine parts, and the remaining power is emitted to the surroundings and transmitted to the other machine parts via contacts in the assembly. Propagation of the waves through the elastic structure of the gear unit (gears, shafts, housing) can excite natural vibrations of the gear unit parts, thus increasing disturbance power transferred to the other parts and emitted to the surroundings.

Fig. 2 shows processes of distribution, spreading and transmission of disturbance energy in the gear transmission unit, while Fig. 3 shows energy flows through the gear unit assembly. The elastic structure of the gear absorbs the disturbance power W_g , generated by teeth impacts, in the form of inner elastic waves. A part of this power is transmitted from the gear to the shaft W_{sh} via direct contact. The quantity $\zeta_{T(g-sh)} = W_{sh} / W_g$ presents the transmission factor of disturbance energy from the gear to the shaft.

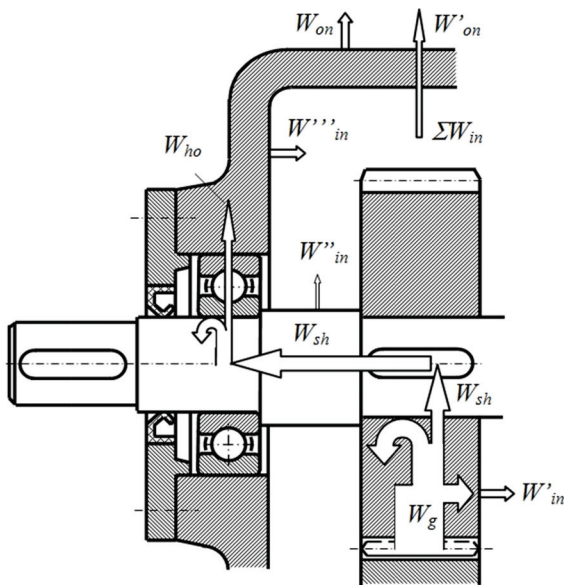

Fig. 3. Disturbance energy transmission through the elastic structure of the gear unit

The remaining part of disturbance energy W'_{in} is transmitted via other gear surfaces into the inner space of the transmission unit. The disturbance energy transmitted to the shaft W_{sh} is partially transmitted to the housing W_{ho} , while a part of the energy is emitted to the inner space of the gearbox W'''_{in} .

The disturbance power transmitted to the housing W_{ho} can produce several effects. The first effect is further transmission of disturbance energy to the air outside and inside the gearbox, in the form of outer noise W_{on} and inner noise W''''_{in} . The second effect of the housing is attenuation or intensification of the energy W_{ho} due to the excitation of natural vibrations.

In addition, excited natural (modal) vibrations of the housing modulate frequencies of emitted noise. The third effect of housing is the noise isolation of outer space from the inner noise ΣW_{in} . The noise transmission factor through the housing walls may be defined as $\zeta_{T(n)} = W'_{on} / \Sigma W_{in}$.

The presented analysis makes use of transmission factors to describe a transmission of disturbance power components. The calculation of disturbance power and transmission factors is a complex problem. It represents a wide area for research and this paper proposes a method for calculation of transmission factors that relies on experimental measurements.

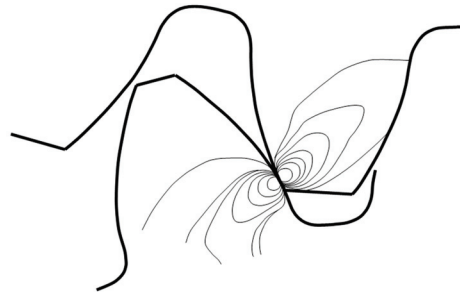

Fig. 4. Stress distribution in the elastic structure after teeth impact

The disturbance energy W_g is absorbed by elastic deformations of machine parts. Fig. 4 represents the distribution of stress within teeth at the moment of collision. The value of wave energy E_w absorbed by elastic deformation may be calculated by integration of the stress σ over the deformed volume V . The wave energy E_w represents the energy of one impact of the teeth. As the teeth collide with the teeth mesh frequency f , the disturbance power absorbed by the gear W_g may be calculated as follows:

$$W_g = E_w f = E_w \frac{zn}{60}, \quad E_w = \int_V \sigma dV. \quad (2)$$

The respective stress distribution which leads to a calculation of disturbance power may be calculated using FEM or by experimental measurements using the photometric method.

The transmission factors ζ_T depend on the characteristics of materials, shape and size of the contact surface, surface roughness and other influences, which makes the theoretical calculation of transmission factors a very difficult task. However, experimental measurement of the transmission factors is possible. Fig. 5 presents two examples of experimental setups, which are adapted for the photometric measurements of stress distribution

caused by impact. Transmission through the surface contact between two parts (Fig. 5a) may be characterized by simultaneous photometric measurements of stress distributions in the parts. Input disturbance may be generated by a modal hammer that enables measurement of impact force variation.

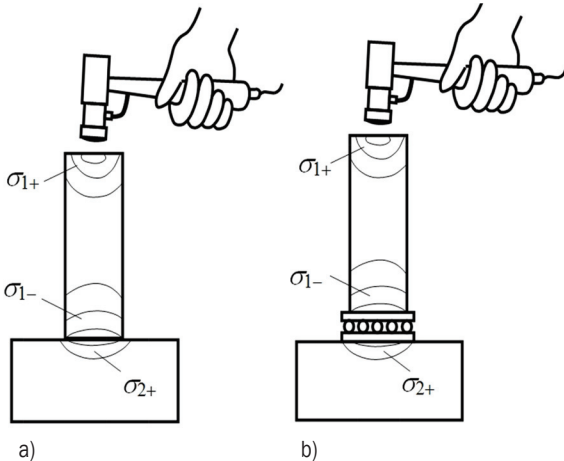

Fig. 5. Experimental setups for determination of the transmission factor

By numeric integration of stress distributions according to Eq. (2), the transmission factor may be calculated from experimental data as follows:

$$\zeta_T = \frac{E_{w2+}}{E_{w1+}}, \quad E_{w1+} = \int_V \sigma_{1+} dV, \quad E_{w2+} = \int_V \sigma_{2+} dV, \quad (3)$$

with indices 1 and 2 referring to the contact parts, and indices + and - referring to the receiving and emitting sides of the parts, respectively.

A measurement of transmission factors through bearings is more intricate, but can be accomplished in a similar manner, and by using the same devices. A possible experimental setup, in which the bearing is placed between two parts whose stress distributions are measured, is shown in Fig. 5b. The procedure for calculation of transmission factors is the same as in the previous example.

The power of an emitted sound may be determined on the basis of the fact that machine parts, including the gear unit housing, emit sounds by vibration of their surfaces as membranes. The surface motion is the result of elastic wave motion in the elastic structure of the parts. Sound waves in the air are longitudinal waves and only surface displacements along a certain direction contribute to the emitted sound. Fig. 6 presents motions of an elementary part of the surface.

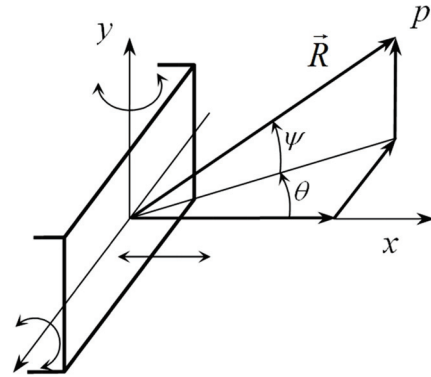

Fig. 6. Motion of surface particles and disturbance energy transmission

Displacements with the components normal to the surface, and therefore translation in the *x* direction and rotations around the *y* and *z*-axes, contribute to the sound emission. Other motions, translation in the *y* and *z* directions, and rotation around the *x*-axis do not contribute to the sound emission. Using the Helmholtz calculation model and the method of boundary elements, the pressure *p* of the sound wave emitted by the motion of the elementary part may be calculated. Sound pressure enables calculation of the intensity of the emitted sound, and the sound power *W_n*, emitted by the machine may be calculated by integrating the sound intensities emitted by all elementary parts over a surface that envelops the machine. Due to large differences between densities of the machine parts and the surrounding air, an extremely small part of disturbance energy is transmitted from the machine part to the surroundings.

The sound power *W_n* of the gear unit is the result of multiple noise components. The first component is the result of forced vibrations of the housing surface due to the conduction of disturbances caused by gear meshing. The second component is the noise produced by natural (modal) vibrations of the housing. The housing sensitivity to modal excitation and the intensity of modal vibrations are parameters influencing the outside noise. The third component of the noise emitted to the surroundings is the noise that comes through the housing walls. Isolation abilities of the housing walls and the level of inside noise define the effect of the third component on the total level of sound power of the gear unit.

The presented analysis underlines important effects of the gear unit housing on the emitted sound power. In addition, the housing modulates sound frequencies with respect to the frequencies of disturbances. For that reason, the modal behavior of the housing has a strong influence on the emitted

sound. Also, the way (mechanism) of certain modal shape excitation and intensity of respective vibrations provide important information for establishing the model of noise generation in machine systems.

3 THE SOUND MODULATION BY HOUSING MODAL BEHAVIOR

According to Fig. 3 and the analysis presented, the sound (noise) emitted by a gear unit is the part of disturbance energy released via the outer surface of the housing. The sound power W_{on} is the result of modal behavior of the housing walls, and the sound power W'_{in} is the result of transmission of the inner noise $\sum W_{in}$ through the housing walls. The relative contributions of W_{on} and W'_{on} depend on housing modal sensitivity and isolation ability. The spectrum of the outer noise is different in comparison to vibration spectra of disturbance sources. In this way, the housing performs modulation of the sound emitted to the surroundings. It is an extremely important detail for diagnostics and similar application of noise emission measurements. With the goal of identifying the modulation process, the modal analysis by FEM, a numerical calculation of frequency responses and modal testing of real gearbox housing were performed.

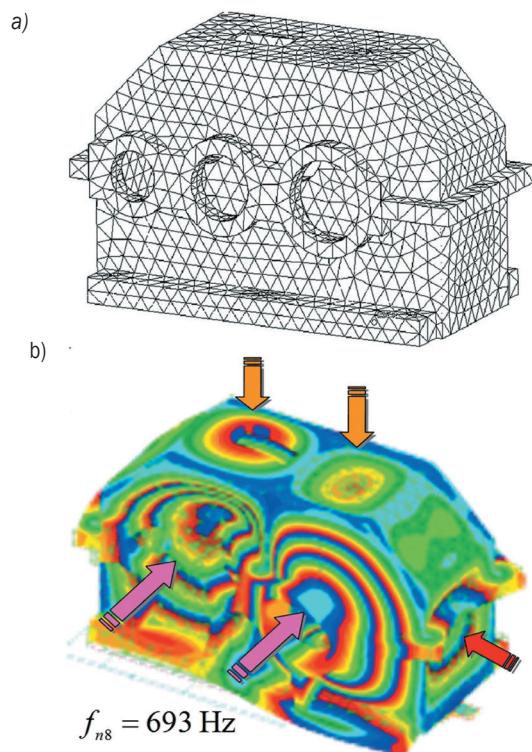

Fig. 7. The selected gearbox housing: a) discretized model, b) modal shape of a vibration mode

The research of modal behavior effects was performed on a housing model shown in Fig. 7. It is a casted housing of a two-degree gear drive, reinforced with ribs and rings for increasing stiffness. The complex shape of the housing is suitable for the investigation of excitation mechanisms of natural vibrations of mechanical structures.

Modal analysis of the given housing was performed by an application of the finite elements method. The linear 3D-brick finite element with 12 degrees of freedom (three translations per each node) was used. The finite elements mesh shown in Fig. 3a contains 6,385 finite elements, 12,950 nodes with 38,850 degrees of freedom. For the frequency range 0-3000 Hz, 88 natural frequencies and modal shapes of vibrations were calculated. Each vibration mode implies the existence of standing waves within separate zones of the considered structure. As an illustration, one of the vibrating modes is presented in Fig. 7b.

3.1 Conditions for Certain Modal Shape Excitations

The sound power W_{on} is the result of excited modal shapes of the housing walls. In real conditions, only a small number of vibration modes, out of a large number (theoretically infinite) of possible modes, are active. The main conditions for excitation of a certain modal shape are the following:

- The direction of elastic deformations caused by excitation (completely or partly) should coincide with the elastic deformations of a certain modal shape;
- The frequency of excitation should be close or equal to the frequency of the modal shape which is excited;
- The modal attenuation should be sufficiently small to prevent partial or complete attenuation of the vibration mode.

These conditions were investigated by the numerical integration method and experimental modal testing for various cases of excitation. The main investigated variable was the excitation impact force. Variations of its direction, place of action and intensity provided a possibility to excite various modal shapes. The excitation frequency depends on variation of the intensity of excitation force during impacts. In numerical integration, the intensity of impact force was increased linearly from zero to 1000 N and decreased back to zero in 0.02 s. In experimental tests, the excitation was performed by a modal hammer. In both cases, the excitation had sufficiently wide frequency spectra to excite all the vibration modes

obtained by FEM analysis. Modal attenuation depends on the material and modal shape. The performed numerical integration considered housings made of steel and cast iron, while experimental tests were carried out on the housing entirely made of cast iron.

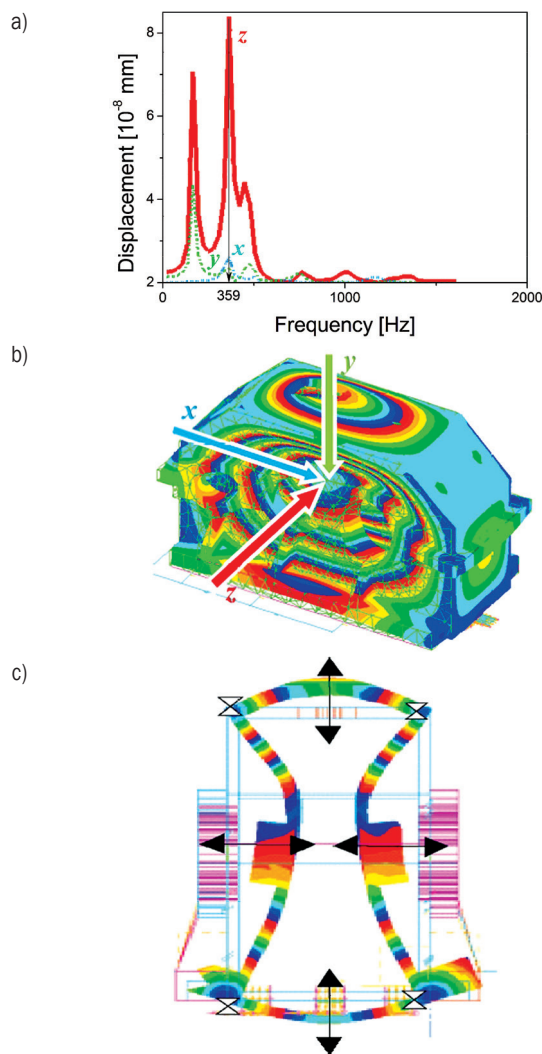

Fig. 8. The example of using the results of numerical modal excitation by impulse force; a) numerical integration results, b) modal shape displacement in chosen sections (359 Hz), c) exciting force directions

Fig. 8 presents, as an example, one of the results of numerical integration of response of the housing, which was excited in the area of maximal modal displacement of vibration mode with the frequency of 359 Hz. In addition to the corresponding modal shape, modes with similar shapes and frequencies were also excited. By the force in the z direction, in the area of the middle hole, vibration modes with

the natural frequencies 155 and 359 Hz are excited (Fig. 8a), because the force direction is the same as the direction of maximal displacement for these modal shapes (Figs. 8b and c). By action of the force in the x and y directions, the modal shape with 359 Hz is not excited, because these directions do not correspond to the displacements of the vibration mode. The force in the y -direction excites only the modal shape with 155 Hz, because the force direction corresponds to the displacement direction of vibration mode with this frequency. The maximal response is obtained with the excitation force that acts at the place and in the direction of maximal displacement of a vibration mode and has the frequency equal to the natural frequency of the vibration mode.

Measurements and analysis of vibrations and noise were performed by the application of B&K PULSE measurement system [19]. Modal testing of the gear unit housing was carried out by means of impulse excitation – the modal hammer, and measurement of vibrations, which were analyzed by an FFT frequency analyzer in the frequency range 0 to 3000 Hz. Fig. 9a, shows the positions of points of modal hammer action T1 to T11, and of point MT0 where the response was measured. As an example, Fig. 9b shows a comparison of frequency responses obtained by excitation at points T6 (in the middle of the lateral side of the housing) and T7 (at the front vertical wall, right above the point MT0). The results of experimental measurements of modal response are similar to the numerically obtained results. Differences between the calculated and measured natural frequencies vary between 0.7 and 9%. With the increase of frequency, the difference decreases.

Considering that the research was aimed at studying vibrations caused by gear impacts, further research was focused on the vibrations that are excited by force acting at point T11. The point is located at the contact surface between the housing and the bearing, and the corresponding excitation force has a radial direction, aimed at the y -direction at point T11.

Fig. 10a shows the measured transfer function. Out of the possible 88 vibration modes numerically calculated by modal analysis, the impulse excitation at point T11 excites 23 modes. Some of excited modal shapes are shown in Fig. 10b.

3.2 Modal Excitation by Teeth Impacts

The response obtained with the modal hammer acting on the housing walls can be different in comparison to vibrations of the transmission unit in operating conditions.

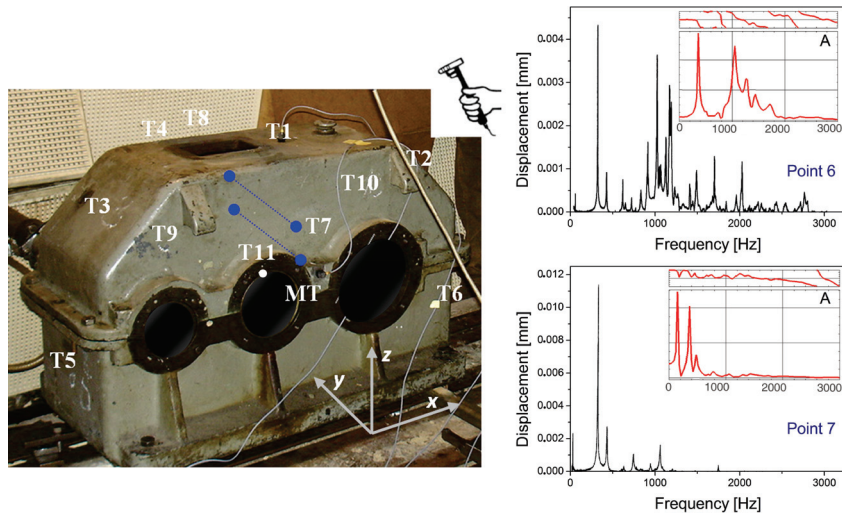

Fig. 9. Amplitude-frequency diagrams of vibrations obtained by modal testing and numerically (insert A)

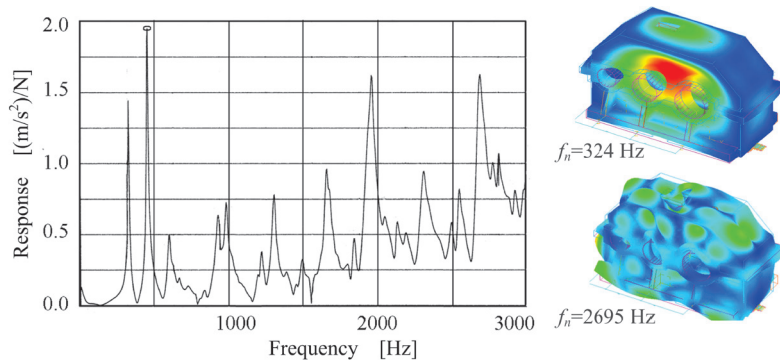

Fig. 10. Modal responses of the housing; a) response measured at point MT0 due to excitation at point T1, b) some of excited modal shapes obtained numerically

There arises a question - which natural frequencies and vibration shapes in the housing walls could be excited by excitation that is transmitted through the bearings? The procedure of predicting modal shapes of vibration primarily begins with the selection and consideration of only those shapes of vibrations in which deformations exist in the area of holes intended for placement of bearings. In order to satisfy the first condition for excitation of a modal shape, it is necessary to have the point of action of disturbance in the area where deformations exist in the modal shape. This means that all modal shapes that do not have deformations in the area of holes for placement of bearings should be excluded from further consideration.

Disturbances are transmitted from the teeth mesh through the bearings to the housing in the axial (z) and radial ($x - y$) directions. The radial direction corresponds to the direction of the gear pair contact

line. Dissipation, i.e. attenuation in the contacts of parts (gear-shaft-bearing-housing) cause a weaker response in comparison to the case of direct impact in the housing walls in the area of bearing hole. For the purpose of characterizing transmission factors of disturbances between the shaft and the housing, a set of experiments in the form of modal testing was carried out. Fig. 11a presents the diagram of response of the housing excited by impact inside the bearing hole, in the direction of the gear contact line. This diagram is compared to the diagram presented in Fig. 11b, which shows the response of the housing with mounted bearings, middle shaft and gear. The excitation was carried out by modal hammer acting at a gear tooth. The additional components changed the modal response of the system, especially its intensity. From the comparison between the responses presented in Fig. 11 the following may be concluded:

- In the presented frequency spectra, the strongest response corresponds to the high frequency range, 2 to 3 kHz.
- When the excitation force acts in the area of the bearings (the area of thick housing walls), the maximum response corresponds to the frequency range 2 to 2.4 kHz (Fig. 11a).
- When the excitation force acts upon the tooth addendum of the middle gear, the maximum response corresponds to the frequency range 2 to 3 kHz, but its intensity is approximately six times lower than in the previous case (Fig. 11b).
- Frequency spectra of the responses are similar in both cases, having the components with the same frequencies.

In the case of excitation of the tooth addendum with a modal hammer, the absorbed disturbance energy is transmitted from the gear body through the shaft and bearings. A large part of that energy is dissipated, causing a very low level of response of the housing. However, the presented analysis shows that the response of the gear unit in operating conditions consists of the same natural vibrations as the response of the housing to excitation by the modal hammer at the place of the bearing.

4 EXPERIMENTAL PROOF OF THE EFFECT OF THE GEAR UNIT HOUSING ON THE EMITTED NOISE

In order to prove the main hypothesis that the housing of housing vibrations and noise caused by gear pair rotation with strong teeth impacts were carried out. With the goal to separate the influences of gear excitation and housing strong teeth collision in the course of slow rotation were excited. Two teeth, symmetrically distributed around the pinion, were intentionally damaged by welding. The damage

caused strong impacts of the gear flanks. During the test, the pinion rotated with 500 rpm and the two damaged teeth caused impacts with the frequency of 16 Hz. By comparing the response diagram of modal testing (Fig. 11) and the frequency spectrum of housing vibration (Fig. 12a), it is possible to notice that there is only one harmonic with the frequency of 16 Hz produced by teeth impacts, and the remaining spectral components are natural vibrations of the gear housing.

Another experiment was designed to confirm the hypothesis that the noise emitted into the surroundings by the gearbox is the consequence of natural vibrations of the housing. For that purpose, the sound pressure of the gearbox was measured at the distance of 0.5 m above the gearbox. The frequency spectrum of noise of the gear unit, for the driving shaft speed of 500 rpm, is presented in Fig. 12b. By comparing these spectra with the spectrum of housing vibrations in Fig. 12a, the following can be concluded:

- Natural vibrations of the gear unit housing produced by impacts of damaged teeth (16 Hz, Fig. 12a) have stronger intensity in the range of lower frequencies because the excitation frequency is low.
- The noise spectrum of the gear unit (Fig. 12b) is similar to the spectrum of vibrations of the housing because the noise is mainly produced by natural vibrations of the housing that follow each of teeth impacts. Vibrations of the structure produce sound, but only if certain conditions (Fig. 6) are met: in this case, strong vibrations with the frequencies around 700, 1000 and 2000 Hz produce only a low level of noise.
- Stronger responses in the frequency spectrum of noise (Fig. 12b) correspond to the frequencies of natural vibrations of the housing that are

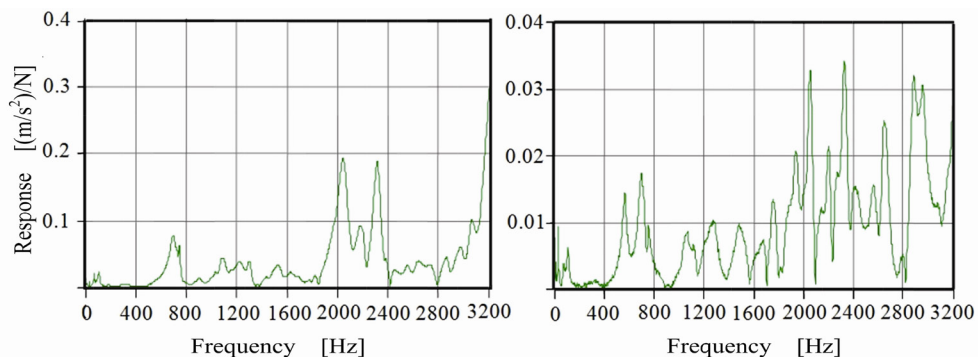

Fig. 11. Comparison of the results of modal tests of the housing with the gear system; a) excited by the impact inside the bearing hole in the direction of the gear contact line, b) excited by the impact at the tooth addendum of the middle gear

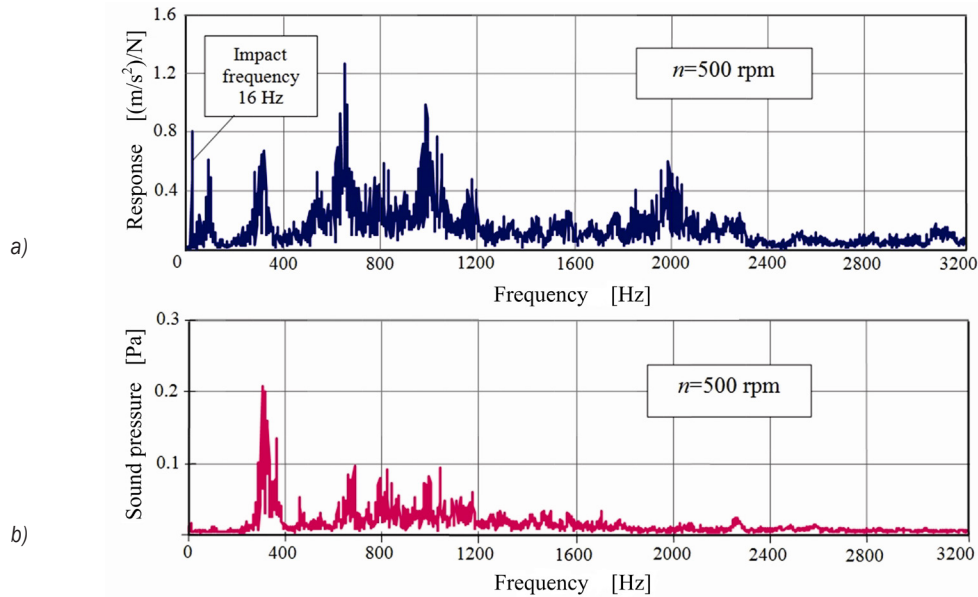

Fig. 12. Comparison of vibration acceleration spectrum; a) and noise pressure spectrum, b) of the gear drive unit with strong impact simulation in the gear mesh

more effective in the sound emission. One of the vibrations has the frequency of around 359 Hz, and it was identified by modal analyses of the housing and by modal testing.

- Vibration and noise spectra presented in Fig. 12 prove the hypothesis that the housing modulates noise emitted by the gear unit.
- The effectiveness of noise modulation of the housing is in direct relation with design parameters of the housing. Housings with lower sensitivity to disturbances and higher attenuation will have lower levels of emitted noise.

The disturbance power W_g is in direct relation with the angular speed of the driving shaft and with intensity of teeth collision. The frequency of impacts, related to the speed, is one of the key parameters of disturbance power absorption Eq. (2). Increase of the angular speed results in a significant increase of the excitation frequency, absorption of disturbance power and the level of noise of the corresponding natural frequencies of the housing.

5 CONCLUSION

The main hypothesis of the presented investigation has been proved: the gear unit housing has a dominant effect on the level and frequency content of the emitted noise of the gear unit. The conclusion is

supported by the following facts and results of the presented research:

- The noise emitted by the gear unit is the consequence of disturbing energy absorbed during the operation of machine parts;
- The disturbing power absorbed in the elastic structure by addendum teeth impact contributes to restorable free vibrations of the gears.
- The transmission of disturbance power through the gearbox elastic structure is explained and the corresponding transmission factors are introduced.
- The modal behavior of the gear unit housing is investigated and the mechanism of excitation of certain modal shapes of natural vibration are explained.
- The gearbox noise modulation by the gear unit housing is the result of housing modal sensitivity and housing ability isolation of internal noise.

A set of questions for further research is open. The transmission factors of disturbance energy through the elastic structure are defined, but their exact calculation and measurement need further research efforts.

6 ACKNOWLEDGEMENT

This paper is a contribution to the project TR 035006 funded by the Ministry of Education and Science of the Republic of Serbia.

7 REFERENCES

- [1] Velex, P., Ajmi, M. (2006). On the Modeling of Excitations in Geared Systems by Transmission Errors. *Journal of Sound and Vibration*, vol. 290, no. 3-5, p. 882-909, DOI:10.1016/j.jsv.2005.04.033.
- [2] Tuma, J. (2006). Dynamic Transmission Error Measurements. *Engineering Mechanics*, vol. 13, no. 2, p. 101-116.
- [3] De la Cruz, M., Rahnejat, H. (2008). Impact dynamic behaviour of meshing loaded teeth in transmission drive rattle. *Proceedings of the Sixth EUROMECH Nonlinear Dynamics Conference*, p. 418-430.
- [4] Houser, D.R., Harianto, J. (2008). Microgeometry and bias in helical gear noise excitations. *Gear Solutions*, feb., p. 21-39.
- [5] Houser, D.R., Harianto, J., Ueda, Y. (2004). Determining the source of gear whine noise. *Gear Solutions*, feb., p. 17-22.
- [6] Barthod, M., Hayne, B., Tebec, J.L., Pin, J.C. (2007). Experimental study of dynamic and noise produced by a gearing excited by a multy-harmonic excitation. *Applied Acoustics*, vol. 68, no. 9, p. 982-1002, DOI:10.1016/j.apacoust.2006.04.012.
- [7] Theodossiades, S., Natsiavas, S. (2000). Nonlinear dynamics of gear-pair systems with periodic stiffness and backlash. *Journal of Sound and Vibration*, vol. 229, no. 2, p. 287-310, DOI:10.1006/jsvi.1999.2490.
- [8] Gnanakumarr, M., Theodossiades, S., Rahnejat, H., Menday, M. (2005). Impact-induced vibration in vehicular driveline systems: theoretical and experimental investigations. *Proceedings of the Institution of Mechanical Engineers, Part K: Multi-body Dynamics*, vol. 219, K01804.
- [9] Theodossiades, S., Tangasawi, O., Rahnejat, H. (2007). Gear teeth impacts in hydrodynamic conjunctions promoting idle gear rattle. *Journal of Sound and Vibration*, vol. 303, no. 3, p. 632-658, DOI:10.1016/j.jsv.2007.01.034.
- [10] Tangasawi, O., Theodossiades, S., Rahnejat, H. (2007). Lightly loaded lubricated impacts: Idle gear rattle. *Journal of Sound and Vibration*, vol. 308, no. 3-5, p. 418-430, DOI:10.1016/j.jsv.2007.03.077.
- [11] Kartik, V., Houser, D.R. (2003). An investigation of shaft dynamic effects on gear vibration and noise excitation. *SAE International*, p. 1737-1746, DOI:10.4271/2003-01-1491.
- [12] Guan, Y.H., Lim, T.C., Shepard W.S. (2005). Experimental study on active vibration control of a gearbox system. *Journal of Sound and Vibration*, vol. 282, no. 3-5, p. 713-733, DOI:10.1016/j.jsv.2004.03.043.
- [13] Rigaud, E., Mayeux, F., Driot, N., Perret-Liaudet, J., Mevel, B. (2003). Dispersion of critical rotational speeds of gearboxes: Effect of bearing stiffnesses. *Mechanique & Industries*, vol. 4, no. 2, p. 107-112, DOI:10.1016/S1296-2139(03)00016-2.
- [14] Houser, D.R., Sorenson, J.D., Harianto, J., Wijaya, H., Satyanarayana, (2002). Comparison of analytical predictions with dynamic noise and vibration measurements for a simple gearbox. *Proceedings of International Conference on gears, vol. 2, VDI-Berichte*, p. 995-1002.
- [15] Inoue, K., Yamanaka, M., Kihara, M. (2002). Optimum stiffener layout for the reduction of vibration and noise of gearbox housing. *Journal of Mechanical Design*, vol. 124, no. 3, p. 518-523, DOI:10.1115/1.1480817.
- [16] Abbes, M.S., Bouaziz, S., Chaari, F., Maatar, M., Haddar, M. (2008). An acoustic-structural interaction modeling for the evaluation of a gearbox-radiated noise. *International Journal Mechanical Sciences*, vol. 50, no. 3, p. 569-577, DOI:10.1016/j.ijmecsci.2007.08.002.
- [17] Tuma, J. (2009). Gearbox noise and vibration prediction and control. *International Journal of Acoustics and Vibration*, vol. 14, no. 2, p. I-II.
- [18] Ognjanovic, M., Agemi, F. (2010). Gear vibrations in supercritical mesh-frequency range caused by teeth impacts. *Strojniški vestnik - Journal of Mechanical Engineering*, vol. 56, no. 10, p. 653-662.
- [19] Ciric-Kostic, S., Ognjanovic, M. (2007). The noise structure of gear transmission units and role of gearbox walls. *FME Transactions*, vol.35, no. 2, p. 105-112.