

THE USE OF THE HOOK-JEEVES METHOD FOR THE CALCULATION OF COMPLEX NONLINEAR EQUIVALENT MAGNETIC CIRCUITS

UPORABA METODE HOOK – JEEVES ZA IZRAČUN KOMPLEKSNIH NELINEARNIH ENAKOVREDNIH MAGNETNIH VEZIJI

Mykhaylo Zagirnyak³¹, Oksana Usatiuk¹, Volodymyr Usatyuk¹

Keywords: Magnetic system, flow distribution, section method, equivalent circuit, multidimensional parametric optimization, scalarization, criteria-weighted sum method, electromagnetic separator.

Abstract

The Hook-Jeeves method was used as a basis for the development of a magnetic system mathematical model suitable for carrying out engineering and optimization design calculations. It provides minimum expenditure for preparation of initial data, acceptable counting time and automatic convergence at a large interval of input parameter variation. The proposed model also enables highly accurate calculation of nonlinear equation systems describing complex nonlinear magnetic circuits. It is demonstrated that this approach can be used for the creation of design methods for direct current electric devices, in particular, electromagnetic separators.

³¹ Corresponding author: Prof. Mykhaylo Zagirnyak, Kremenchuk Mykhailo Ostrohradskyi National University, Department of Electric machines and Apparatus, vul. Pershotravneva, 20, 39600, Kremenchuk, Ukraine, Tel.: +38 05366 36218, E-mail address: mzagirn@kdu.edu.ua

¹ Kremenchuk Mykhailo Ostrohradskyi National University, Department of Electric machines and Apparatus, vul. Pershotravneva, 20, 39600, Kremenchuk, Ukraine

Povzetek

Hook-Jeeves metoda je bila uporabljena kot podlaga pri razvoju matematičnega modela magnetnega sistema, primerneza za izvedbo inženirskih izračunov in optimizacije pri načrtovanju. Zagotavlja minimalne izdatke pri pripravi začetnih podatkov, sprejemljivega časa štetja in avtomatsko konvergenco v velikem intervalu variacij vhodnih parametrov. Predlagani model omogoča pridobivanje visoko natančnih izračunov sistemov nelinearnih enačb, ki opisujejo zapletena nelinearna magnetna vezja. Predstavljen pristop je možno uporabiti pri oblikovanju metod za načrtovanje električnih naprav na enosmerni električni tok, zlasti elektromagnetnih ločevalnikov.

1 INTRODUCTION

The determination of flux distribution and optimization of magnetic loads in magnetic circuits of various electric devices are carried out on the basis of the calculation of their magnetic systems. The lumped element method is one such calculation method commonly used in engineering, [1]. According to this method, the whole magnetic field is divided into local areas, and the magnetic circuit is divided into a number of sections, and the magnetic circuit device with distributed parameters is substituted by an equivalent complex branched electric circuit with lumped nonlinear parameters. This circuit consists of k nodes, l branches. It is known that, to describe this circuit, $(k - 1)$ independent equations can be formulated according to Kirchhoff's first law for the magnetic circuit and $(l - k + 1)$ equations according to Kirchhoff's second law.

However, application of conventional numerical methods (e.g. Seidel's method, Newton's method, etc.), based on relevant iteration processes for the solution of nonlinear equation systems describing electric device equivalent magnetic systems [1], is hampered by a number of challenges. First, the preparation of initial data is laborious: the necessity for the formulation of a Jacobian matrix according to partial derivatives for all the equations in the system; the necessity for assignment of the vector of initial values of the required flux, etc. Second, possible failure of meeting the condition of the iteration process convergence because of the high degree of nonlinearity of the system. Moreover, particular difficulties in the practical realization of these methods are related to the presentation of the solved system as a certain function in a multidimensional space.

2 THEORETICAL OUTLINE

The purpose of this paper consists in the creation of a magnetic system mathematical model suitable for carrying out engineering and design calculations. Furthermore, it must guarantee minimum expenditure for the preparation of initial data, acceptable counting time, and automatic convergence at a large interval of input parameters and, at the same time, be sufficiently accurate.

The basis of this mathematical model can be presented by a system of nonlinear algebraic equations written according to Kirchhoff laws. It should describe the equivalent magnetic circuit created by the section method. Such an equation system can be transformed into a mathematical model of multi-criteria parametric optimization, [2].

$$\min_{\vec{x}} \{f_1(\vec{x}), f_2(\vec{x}), \dots, f_k(\vec{x})\},$$

where each of the equations in the system will represent a separate objective function $f_i : R^n \rightarrow R$.

In a general case, equations written according to Kirchhoff's first and second laws for the magnetic circuit

$$\sum_{j=1}^n \Phi_j = 0, \quad \sum_{k=1}^n U_k = \sum_{l=1}^m F_l,$$

cannot be used as objective functions, because it cannot be stated that they are restricted from below and it is possible to find a solution vector that will provide the minimum value $f(\vec{x}^*)$ of the given function $f(\vec{x})$ (Fig. 1, solid line).

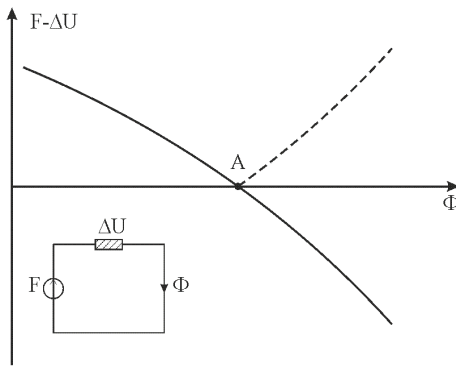

Figure 1: Graphic presentation of magnetic potential closure error in a flux function for a single-loop equivalent circuit (Kirchhoff second law)

To guarantee meeting the requirements to the objective functions within the limits of the solution to the problem of parametric optimization, the equation data are to be presented in the form:

$$f(\vec{x}) = \left| \sum_{j=1}^n \Phi_j \right|; \quad f(\vec{x}) = \left| \sum_{k=1}^n U_k - \sum_{l=1}^m F_l \right|$$

In this presentation, the equations for Kirchhoff first and second laws will be restricted from below by zero at one point (Fig. 1, point A). This point corresponds to the required solution of the initial problem of calculation of flux distribution in the magnetic system.

A reworked mathematical model of optimization is formed on the equation system adequately describing the real magnetic system and physical processes taking place in it. So, it can be stated that the vector of solution to the problem $\vec{x} = (x_1, x_2, \dots, x_n)^T$ will belong to non-empty set $\vec{x} \in S$.

Due to the same circumstance, it can also be stated that the vector objective function formed in such a way is convex, and the mathematical model has one global optimum in which the solution vector reflects the only real flux distribution in this magnetic system.

Eventually, the solution to the problem of multi-criteria optimization consists in the search for objective variables (fluxes) vector, meeting the imposed constraints and optimizing the vector function whose elements correspond to the objective functions (the equations of the system).

To lower the degree of optimization of the mathematical model (reduction of the number of objective variables and the number of objective functions), a convolution method, [3], can be used. This method is based on the acceptance of initial values of several fluxes (fluxes-arguments) with the following determination of all the others on the basis of equations of the solved problem. In this case, the same number of equations written by Kirchhoff's second law and included in the system (characteristic equations of the system) remain unused in the process of convolution during the determination of all the fluxes. Thus, it is these initially accepted fluxes-arguments that will be the controlled parameters of optimization, and the characteristic equations will be included into the vector objective function.

As all the objective functions in this problem statement will be of equal weight (the criteria are homogeneous) and mutually "non-conflictive", it is possible to perform scalarization of the vector objective function by the method of weighted sum of criteria (MWSC), [4]

$$F(\vec{f}(\vec{x})) = k_1 f_1(\vec{x}) + \dots + k_k f_k(\vec{x}),$$

with all the weight co-efficients equal to one and, thus, to reduce the problem to a one-criterion problem of multidimensional parametric conditional optimization

$$\vec{x}^* \in X: f(\vec{x}^*) = \min_{\vec{x} \in X} f(\vec{x}),$$

where

$$X = \{\vec{x} | g_i(\vec{x}) \leq 0, i = 1, \dots, m\} \subset R^n.$$

In this case, to reduce the counting time, the acceptable set X can be restricted by zero from below, as the initial equation system takes into account the real directions of the fluxes (negative value corresponds to the opposite direction of the flux) and from above – by the fluxes values calculated for the same equivalent circuit without taking into account the drop of magnetic intensity at nonlinear elements (elements with steel).

The choice of the Hook-Jeeves method, [5], was because it refers to one-criterion methods of multidimensional parametric optimization, requires only calculation of the objective function at approximation points (direct method) and constraints meeting support is easily introduced into its algorithm.

3 PROPOSED METHOD AND RESULTS

An equivalent circuit of a roll separator (Fig. 3a) was taken as a calculation equivalent circuit. It is difficult for calculation due to its branched form, and the convergence of five fluxes at node 4 hampers the convolution process. Parameter values (permeances Λ_i and magnetic potential drops ΔU_i) of the magnetic circuit are assumed to be determined by formulas given in [6].

This equivalent circuit (Fig. 3b) is described by the system of equations (Fig. 2).

$$\left. \begin{aligned}
 & \Phi_{C1} - \Phi_{C2} - \Phi_S = 0 \\
 & \Phi_{C2} - \Phi_{P2} - \Phi_{PPV} = 0 \\
 & \Phi_{P2} - \Phi_{SP} - \Phi_{N2} - \Phi_{D1} - \Phi_{V1} = 0 \\
 & \Phi_{D1} + \Phi_{V1} - \Phi_{V3} = 0 \\
 & \Phi_{N2} - \Phi_{D2} - \Phi_{N3} - \Phi_{NNV} = 0 \\
 & \Phi_{D2} + \Phi_{V3} - \Phi_{V4} = 0 \\
 & \Phi_{N3} + \Phi_{D3} - \Phi_{NNT} = 0 \\
 & \Phi_{V4} - \Phi_{D3} - \Phi_{V5} = 0 \\
 & \frac{F}{2} - \Delta U_{C1} - \Delta U_{C2} - \Delta U_{P1} - \frac{\Phi_{PPV}}{\Lambda_{PPV}} = 0 \\
 & \frac{F}{4} - \Delta U_{C1} - \frac{\Phi_S}{\Lambda_S} = 0 \\
 & \frac{F}{4} + \frac{\Phi_S}{\Lambda_S} - \Delta U_{P2} - \Delta U_{P1} - \Delta U_{C2} - \frac{\Phi_{SP}}{\Lambda_{SP}} = 0 \\
 & \frac{\Phi_{SP}}{\Lambda_{SP}} - \Delta U_{N2} - \frac{\Phi_{NNV}}{\Lambda_{NNV}} = 0 \\
 & \Delta U_{V3} + \Delta U_{N1} + \frac{\Phi_{D1}}{\Lambda_{D1}} - \Delta U_{N2} - \frac{\Phi_{D2}}{\Lambda_{D2}} = 0 \\
 & \frac{\Phi_{V1}}{\Lambda_{TV}} + \Delta U_{V1} + \Delta U_{V2} - \frac{\Phi_{D1}}{\Lambda_{D1}} - \Delta U_{N2} = 0 \\
 & -\frac{\Phi_{NNV}}{\Lambda_{NNV}} + \frac{\Phi_{NNT}}{\Lambda_{NNT}} + \Delta U_{N3} = 0 \\
 & \frac{\Phi_{D2}}{\Lambda_{D2}} - \Delta U_{N3} + \Delta U_{V4} - \frac{\Phi_{D3}}{\Lambda_{D3}} = 0 \\
 & \Delta U_{V5} - \frac{\Phi_{NNT}}{\Lambda_{NNT}} + \frac{\Phi_{D3}}{\Lambda_{D3}} = 0
 \end{aligned} \right\}$$

Figure 2: The system of equations

The solution to the above-mentioned equation system concerning 17 unknown parameters is rather difficult. Therefore, to decrease the number of the independent equations, the convolution is used:

- 1) Flux Φ_{C1} is used as the first flux-argument.
- 2) Circuit II. Flux $\Phi_S = \Lambda_S \cdot \left(\frac{F}{4} - \Delta U_{C1}\right)$ is determined.
- 3) Node 2. Flux $\Phi_{C2} = \Phi_{C1} - \Phi_S$ is found.

- 4) Circuit I. Flux $\Phi_{PPV} = \Lambda_{PPV} \cdot \left(\frac{F}{2} - \Delta U_{C1} - \Delta U_{C2} - \Delta U_{P1}\right)$ is determined.
- 5) Node 3. Flux $\Phi_{P2} = \Phi_{C2} - \Phi_{PPV}$ is found.
- 6) Circuit III. Flux $\Phi_{SP} = \Lambda_{SP} \cdot \left(\frac{F}{4} + \frac{\Phi_S}{\Lambda_S} - \Delta U_{P2} - \Delta U_{P1} - \Delta U_{C2}\right)$ is determined.

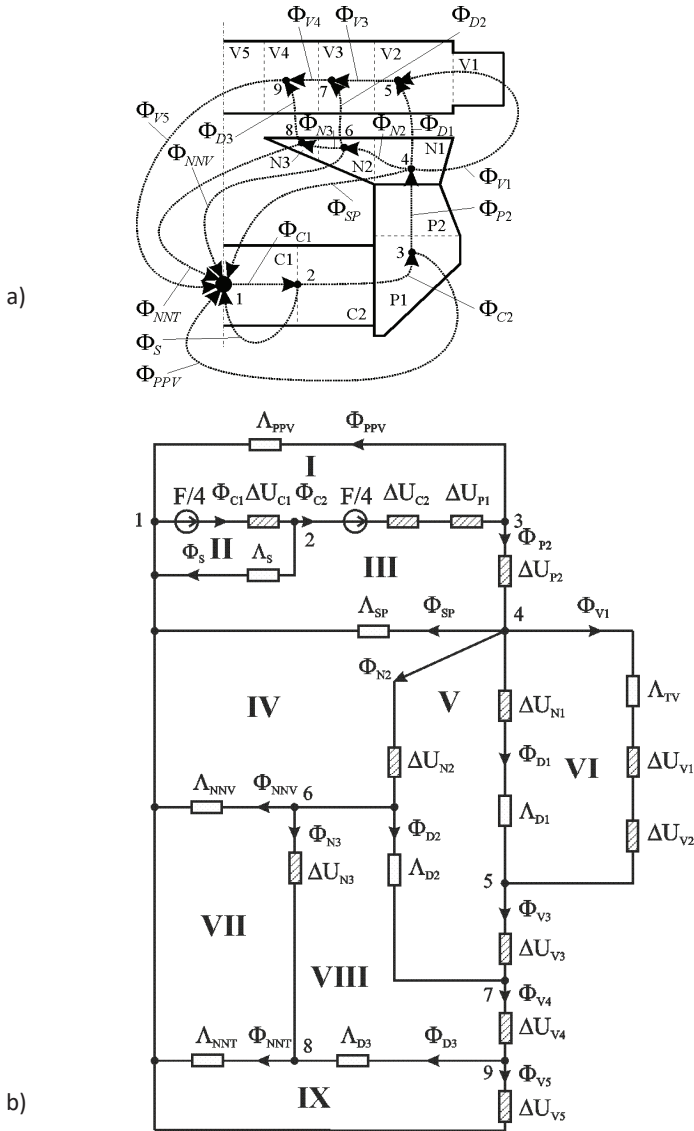

Figure 3: Scheme of flux distribution (a), and equivalent circuit of a roll separator (b)

Thus, fluxes Φ_{P2} and Φ_{SP} are determined via the known value of flux-argument Φ_{C1} by convolution of the equivalent circuit. To solve the equation for node 4 we have to assign two more fluxes-arguments, for which purpose we choose fluxes Φ_{V1} and Φ_{D1} .

7) Node 4. Flux $\Phi_{N2} = \Phi_{P2} - \Phi_{SP} - \Phi_{V1} - \Phi_{D1}$ is found.

8) Node 5. Flux $\Phi_{V3} = \Phi_{D1} + \Phi_{V1}$ is determined

9) Circuit V. Flux $\Phi_{D2} = \Lambda_{D2} \cdot (\Delta U_{V3} + \Delta U_{N1} + \frac{\Phi_{D1}}{\Lambda_{D1}} - \Delta U_{N2})$ is determined

10) Circuit IV. Flux $\Phi_{NNV} = \Lambda_{NNV} \cdot (\frac{\Phi_{SP}}{\Lambda_{SP}} - \Delta U_{N2})$ is found

11) Node 7. Flux $\Phi_{V4} = \Phi_{V3} + \Phi_{D2}$ is found.

12) Node 6. Flux $\Phi_{N3} = \Phi_{N2} - \Phi_{D2} - \Phi_{NNV}$ is found.

13) Circuit VIII. Flux $\Phi_{D3} = \Lambda_{D3} \cdot (\frac{\Phi_{D2}}{\Lambda_{D2}} - \Delta U_{N3} + \Delta U_{V4})$ is determined.

14) Node 9. Flux $\Phi_{V5} = \Phi_{V4} + \Phi_{D3}$ is found.

15) Node 8. Flux $\Phi_{NNT} = \Phi_{N3} - \Phi_{D3}$ is found.

Thus, we managed to determine the remaining 14 fluxes when the values of three fluxes-arguments Φ_{C1} , Φ_{V1} и Φ_{D1} were assumed. Now, the correctness of the assumed initial values of fluxes is to be determined using Kirchhoff's second law for independent closed circuits (that did not take part in convolution). In this case, these are circuits VI, VII and IX (Fig. 3). The characteristic equations of the system are of the form:

$$f_1(\vec{x}) = \left| \frac{\Phi_{V1}}{\Lambda_{TV}} + \Delta U_{V1} + \Delta U_{V2} - \frac{\Phi_{D1}}{\Lambda_{D1}} - \Delta U_{N2} \right|;$$

$$f_2(\vec{x}) = \left| -\frac{\Phi_{NNV}}{\Lambda_{NNV}} + \frac{\Phi_{NNT}}{\Lambda_{NNT}} + \Delta U_{N3} \right|;$$

$$f_3(\vec{x}) = \left| \Delta U_{V5} - \frac{\Phi_{NNT}}{\Lambda_{NNT}} + \frac{\Phi_{D3}}{\Lambda_{D3}} \right|.$$

The scalar form of the objective function will be obtained on the basis of these characteristic equations:

$$F(\vec{f}(\vec{x})) = \left[\left(\frac{\Phi_{V1}}{\Lambda_{TV}} + \Delta U_{V1} + \Delta U_{V2} - \frac{\Phi_{D1}}{\Lambda_{D1}} - \Delta U_{N2} \right) + \left(-\frac{\Phi_{NNV}}{\Lambda_{NNV}} + \frac{\Phi_{NNT}}{\Lambda_{NNT}} + \Delta U_{N3} \right) + \left(\Delta U_{V5} - \frac{\Phi_{NNT}}{\Lambda_{NNT}} + \frac{\Phi_{D3}}{\Lambda_{D3}} \right) \right],$$

which can be minimized by the Hook-Jeeves method in a 3D space of input-controlled parameters (Φ_{C1} , Φ_{V1} and Φ_{D1}).

The calculation results were analogous to those of [7], and the attained accuracy exceeds the accuracies presented in Table 2, [7] for corresponding nodes and circuits.

4 CONCLUSIONS

The obtained results and positive experience make it possible to recommend the application of this approach to the solution of nonlinear equation systems describing complex, branched magnetic equivalent circuits. In turn, the absence of difficulties with the convergence of iteration process of searching solutions to many fluxes-arguments also provides the possibility to abandon simplification of the topology of equivalent circuits and to completely take into consideration the real pattern of flux distribution. Hereafter, the authors will to verify the tempo of the solution of such optimization problems by other methods of multidimensional optimization and use this method in the generation of engineering methods for designing direct current electric devices, in particular, electromagnetic separators.

References

- [1] **M. V. Zagirnyak:** *Electromagnetic calculations: textbook* / M.V. Zagirnyak. – 2nd ed., revised and updated – Kharkov: “Tipografiia Madrid”, p. p. 320, 2015
- [2] **A. F. Izmailov, M. V. Solodov:** *Numerical methods of optimization: texbook* – Moscow: FIZMATLIT, p. p. 304, 2005
- [3] **V. V. Kogen-Dalin, E. V. Komarov:** *Calculation and test of systems with permanent magnets* – Moscow: Energiia, p. p. 248, 1977
- [4] **R.L. Keeney, H. Raiffa:** *Decisions with multiple objectives–preferences and value tradeoffs*, Cambridge University Press, Cambridge & New York, p. p. 569, 1993
- [5] **R. Hooke and T. A Jeeves:** *Direct Search Solution of Numerical and Statistical Problems*, Journal of the ACM, Vol. 8, Iss. 3, p.p. 212-229, 1961
- [6] **M. V. Zagirnyak, I. Yu. Bukhtiiarov, N. I. Kuznetsov:** *Calculation of magnetic systems of roll separators*, Proc. of heigher educ. estab. Elektromekhanika, No. 5, p.p. 84-93, 1993
- [7] **M. V. Zagirnyak, V. M. Usatyuk, O. S. Akimov:** *Modification of the quadrosection method for calculation of complicated equivalent circuits*, Tekhnichna elektrodinamika, No. 2. p. p. 11-14, 2001