

# Uporaba neobičajnih nevronskih mrež za ovrednotenje okoljskih vidikov modeliranja

## The Application of an Atypical Neural Network when Quantifying the Modeling of Environmental Aspects

Jelena Jovanović - Zdravko Krivokapić  
(University of Podgorica, Podgorica)

*Prispevek podaja novo metodo, ki bazira na nevronski mreži, in je vpeljana v fazi ocenjevanja okoljskega vidika. Metoda naj bi zagotovila zadostno objektivnost in natančnost v ocenjevanju vplivov na okolje za vse oblike organizacij in temelji na specifičnosti dosegljivih matematičnih modelov, uporabljenih pri že certificiranih organizacijah v Srbiji in Črni Gori.*

© 2006 Strojniški vestnik. Vse pravice pridržane.

**(Ključne besede: mreže nevronske, zaščita okolja, vidiki okoljski, vplivi okolja, vrednotenje)**

*This paper looks at the environmental aspects' quantification phase, where a new method based on a neural network was initiated. The method should provide sufficient objectivity and accuracy in the assessment of environmental impacts for all types of organization, and it is based on the specificity of available mathematical models used by certified organizations in Serbia & Montenegro.*

© 2006 Journal of Mechanical Engineering. All rights reserved.

**(Keywords: neural networks, environmental protection, environmental aspect, environmental impact, quantification)**

### 0 INTRODUCTORY REMARKS

Implementation of the environmental protection management system according to the ISO 14000 series standards is very arduous work and demands the validation of the following:

- Specificity of the company
- Specificity of the locality
- Validation of the standard's requests
- Validation of the legal regulations

The aspects and impacts on the environment represent the most significant request of the standard and the procedure of environmental protection in general, where further compliance with the requests of the standard does not lead to the complete fulfillment of assigned goals, if it is not defined in details at this point, and in this way the whole work on environmental protection of one organization can be put into question. Concerning the great importance of 4.3.1 requests, the arbitrariness and insufficient accuracy in the approach protected by the standard, represents a stimulus for the investigation toward the quantification of environmental impacts by using scientific methods and work techniques. In particular, the ISO 14004

standard, article 4.3.1.5 justified by the argument "significance is a relative concept: it cannot be defined in absolute terms" gives organizations complete freedom in relation to these problematics. The purpose, to find possibilities for a determination of the unique approach for all organizations in the quantification of environmental impacts, due to the diversity of data and given result, the application of neural networks represents the basis for this paper.

### 1 ENVIRONMENTAL ASPECTS

Aspects of the environment represent a complex field, and also one of the most demanding articles of standards, considering that the efficiency of environmental protection management depends exactly on the substantial and fundamental respect of this request.

The essence of EMS lies in good identification and quantification of the environmental impacts, considering that from there the indicators of environmental protection efficiency originate, whose measurement serves for the determination of the fulfillment level of the appointed general and special goals of the organization and

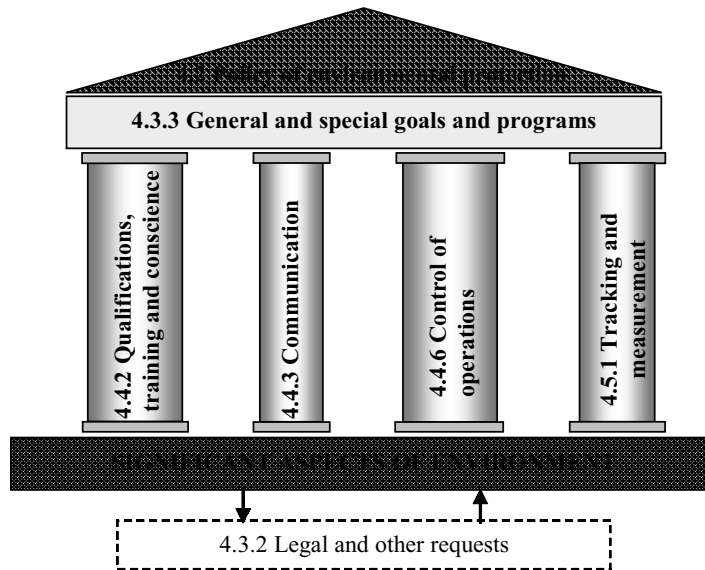

Fig. 1. Articles of the standard, based on significant environmental aspects

evaluation of the system itself. Most of the key articles are based on a knowledge of the significant environmental aspects, such as those presented in Figure 1, while other standard articles stand in certain correlation with them, although they are not entirely dependent on them.

This topic was elaborated in both versions of the standard (ISO 14001:1996 and ISO 14001:2004) under the same title "Environmental aspects" and the same article 4.3.1.

As for the standard ISO 14004, the difference is obvious because ISO 14004:2004 goes more in-depth with the identification processes and the significance of aspects and environmental impacts. The fact that five sub-articles were formulated within the article "Environmental aspects" in ISO 14004:2004,

where the guidelines and recommendations had been given, shows what value this new standard attributes to this request (Figure 2). Through an analysis of 4.3.1 and part of the aspects' significance and the environmental impacts evaluation in the standard ISO 14004, too much freedom of choice can be left for the organizations observed:

- methodology
- significance criterion
- criteria ranking
- limited values of significance

In accordance with this, certification institutions do not enter into the evaluation methodology selected by the organization either. They only analyze the final results and evaluate the way of monitoring and rehabilitation of the

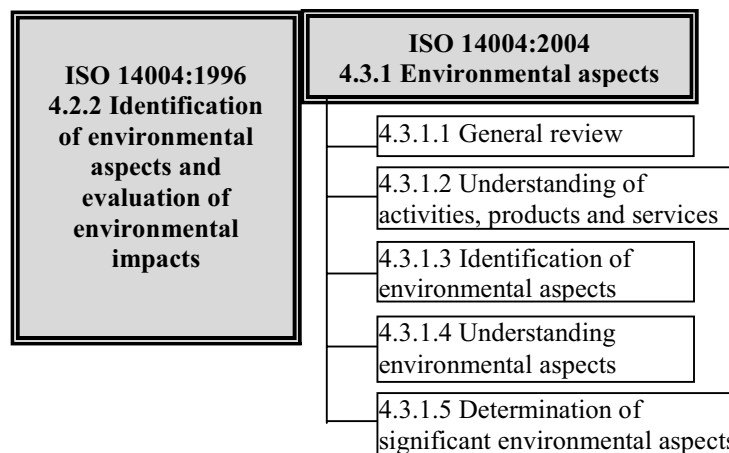

Fig. 2. Structure fact "Environmental aspects" in standards ISO 14004:1996 and ISO 14004:2004

Table 1. Comparison II (A and C)

	C	A	
<b>VOLUME</b>	1	1,2	C (significant) A (insignificant) <b>84</b>
	2	3	
	3	4	
	4	5, 6	
	5	7, 8	
<b>PROBABILITY</b>	1	1, 2	A (significant) C (insignificant) <b>0</b>
	2	3, 4	
<b>IMPACT SEVERITY</b>	1	1	
	2	2	
	3	3	
<b>Influence on public opinion</b>	1	1	
	2		
	3		

significant aspects' consequences. Therefore, this leaves too much room for manipulation with data on which the whole environmental protection management system relies, and the system should be determined to the greatest possible extent. Namely, based on the available data from three certified organizations (A, B and C) in Serbia and Montenegro that are related to the chosen mathematical model and the evaluations of the environmental aspects, a worrying reduction in the number of significant impacts can be seen, depending on the applied verified model, and which cannot be justified by the different activities of the

organizations. A comparative analysis was realized through programming in the JAVA programming language, software package JDK 1.2.2. (Java Development Kit) in the available text editor JCreator 3.50. In order to carry out a comparison of the applied methodology in these organizations, first of all it was necessary to make an adjustment of the evaluation and the selected criteria (e.g., Table 1 for organizations A and C). A comparison was realized for all three organizations, such as follows:

1. Comparison I (organization A and organization B)
2. Comparison II (A and C), Table 1
3. Comparison III (organization B and organization C)

▪ EVALUATION OF ORGANIZATION A

**ENVIRONMENTAL ASPECTS: SIGNIFICANCE EVALUATION CRITERIA**

**Environmental aspects: volume**

<b>Environmental aspect volume</b>	<b>Criteria description</b>	<b>Evaluation</b>
Immediate environment	The consequences of the environmental aspect are limited to the immediate environment of the place of its emergence.	1
Work premises level	The consequences of the environmental aspect are limited to the work premises in which it emerged.	2
Department level	The consequences of the environmental aspect are limited to the department in which it emerged.	3
Operation level	The consequences of the environmental aspect are limited to the operation level in which it emerged.	4
Industrial complex level	The consequences of the environmental aspect are limited to the industrial complex level.	5
Municipal level	The consequences of the environmental aspect are limited to the municipal level.	6
Regional level	The consequences of the environmental aspect include more municipalities.	7
International level	The consequences of the environmental aspect are extended over the state borders.	8

**Environmental aspect: emergence frequency**

Frequency	Criteria description	Evaluation
Small	The environmental aspect emerges only under extreme working conditions (explosion, fire etc.).	1
Medium	The environmental aspect can emerge only under unusual working conditions (power-supply discontinuation, equipment breakdown, irrelevant executor, malicious damage etc.)	2
Big	The environmental aspect can emerge if the executor is negligent, unskilled or the equipment is not maintained.	3
Very big	The environmental aspect emerges under normal working conditions.	4

**Environmental aspect: consequences severity**

Severity	Criteria description	Evaluation
Minor	There are no measurable environmental consequences.	1
Medium	The measured presence of matters which are not dangerous matters, or their influence on the environment is not known.	2
Big	<ul style="list-style-type: none"> <li>• Presence of dangerous matters measured in quantities higher than permitted by law.</li> <li>• Lack of information.</li> </ul>	3

▪ EVALUATION OF ORGANIZATION C

**Public opinion**

- Small impact (1 point) – Loss of reputation of local character, short-term effect.
- Medium impact (2 points) – Loss of reputation of local character, long-term effect.
- Big impact (3 points) – Loss of reputation of regional or wider character, long-term effect.

**Severity of impact**

- Small impact (1 point) – Impact on the environment with insignificant influence on human beings, flora and fauna.
- Medium impact (3 points) – Impact on the environment with a harmful effect on human beings'

**Intensity of impact**

• for waste

Intensity of impact	Quantity
1	to 0.1 t / year
2	from 0.1 t / year to 0.5 t / year
3	from 0.5 t / year to 1 t / year
4	from 1 t / year to 5 t / year
5	over 5 t / year

• for discharges into water / emissions into air

Intensity of impact	Quantity
1	to 1 m <sup>3</sup> / year
2	1–5 m <sup>3</sup> / year
3	5–10 m <sup>3</sup> / year
4	10–100 m <sup>3</sup> / year
5	over 100 m <sup>3</sup> / year

health and/or a temporary impact on flora and fauna.

- Big impact (3 points) – Impact on the environment posing a direct threat to human lives and long-term and/or permanent consequences for the flora and fauna.

**Probability of impact**

- Small probability (1 point) – If the aspect does not have an impact on the environment in the course of technological process realization, but there is a possibility due to failing to keep to technological technical measures of protection, the impact may have an effect.
- Big probability (2 points) – If the aspect has a continuous impact on the environment in the course of technological process realization.

Intensity of the impact on the environment of organization C is analogous with the environmental aspect volume of organization A.

To overcome the stated non-uniformities of certain methodologies but still to adopt their specificities and gained results, we approached the production of a program for the evaluation of the environmental impacts through the application of a neural network. The aim was to establish a model with as little as possible subjectivity in the individual evaluation so as to avoid possible manipulations with the results.

## 2 FEED-FORWARD BACK-PROPAGATION NEURAL NETWORK

The feed-forward back-propagation neural network is most commonly applied in practice because of its simplicity as well as for the wide spectrum of problems it can solve (shape recognition, robot and vehicle management, figure classification, knowledge processing and the other different problems of shape analysis). Considering that the input data available in a certain problem are grouped, and that the exact response is known for every input, a feed-forward back-propagation neural network is the simplest and best solution for the choice of network.

The feed-forward back-propagation neural network belongs to a group of networks that have the following characteristics:

- number of layers: multi-layer
- architecture: layered
- training: statically supervised
- direction of information flow: non-recurrent
- kind of data: discrete static

The feed-forward back-propagation is an abbreviation of "back error propagation", which is translated as the propagation of an error backwards. It is a network with two or more layers; therefore, it has at least one hidden layer, and most commonly networks with completely linked layers are used (Fig. 3).

The linear function of the input interaction is represented by the expression:

$$n_j = \sum p_{ij} \cdot W_{ij}; \quad i=0, \dots, R \quad (1),$$

where  $p_{ij}$  is an input signal of  $j$  units and  $W_{ij}$  is the weight coefficient of the relation that links units  $i$  and  $j$ .

The neuron threshold in this case is represented by a constant input  $p_{0j}=1$  and a weight  $W_{0j}$ . The output signal of the same neuron is:

$$a_j = f(n_j) \quad (2).$$

When the network is excited with a signal =  $(p_1, \dots, p_i, \dots, p_R)$  its response will be  $a = (a_1, \dots, a_s)$ , so during the learning process the difference between the real "a" and the desired response "o" should be minimized, and the error function can be represented by:

$$\varepsilon = \frac{\sum (o_j - a_j)^2}{2} \quad (3),$$

$j = 1, \dots, S$  – the counter of the output signals

The feed-forward back-propagation neural network has two phases in the procedure of training, as follows:

- phase (propagation) forward
- phase (propagation) backward

During first propagation (forward), the computation of all the neuron responses is performed starting from the first, until the last layer, based on

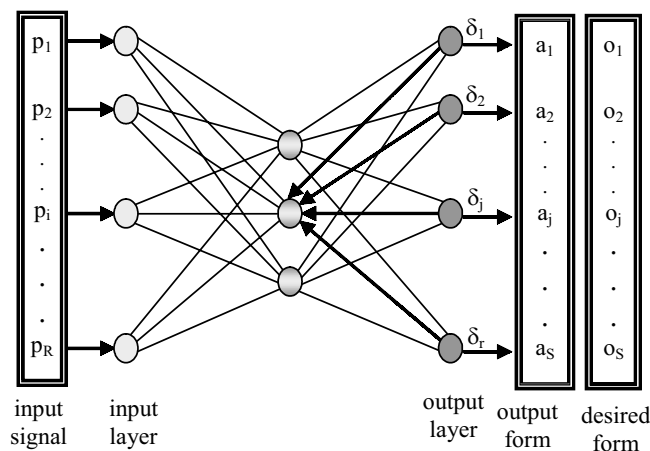

Fig. 3. Two propagation steps of the back-propagation neural network

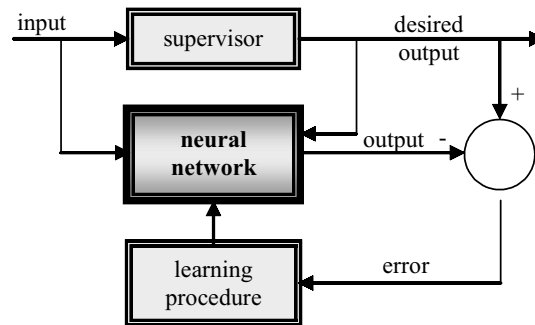

Fig. 4. Supervised (offline) learning

the input signals that are presented to the network. All the weight coefficients are calculated during this phase.

The second propagation (backward) implies the correction of weight coefficients based on the calculated error that is gained as a difference between the real and desired responses. This phase is only finished when the correction of the weight coefficients for all the neurons in all the layers is done.

The statically supervised training of the back-propagation neural network is represented in Figure 4.

After the neural network is trained, the testing of the model by the simulation (test) sample can begin.

For the feed-forward back-propagation network type, in the Matlab software package it is possible to chose the following parameters:

1. Training function
2. Adoption learning function
3. Network performance function
4. Number of neuron layers
5. Number of neurons in layer

#### 6. Transfer function

within the window “Create New Network” represented in Figure 5.

The choice of the training function is of great significance for providing the speed of learning for the given network, i.e., the algorithm. It is difficult to answer in advance the question as to which function will give the best results for the given problem, because there are several factors on which it depends (the number of training samples of the training set, the expected accuracy, the number of neurons in the network, etc.)

The Trainlm network training function, which updates the weight and bias values according to the Lovenberg-Marquardt optimization, gave the best results as regards the concrete problem.

Immediately following the training-function selection, it is placed at the user’s disposal to select an adoption learning function that is related to the manner of the calculation of the weight coefficients change, and which can have a big impact on the speed of convergence and size of the error for certain network and training-function selection.

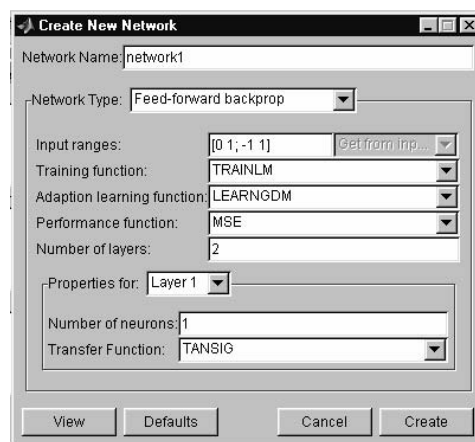

Fig. 5. Choice of back-propagation neural-network performances

The Network Performance Function for the network characteristics' modification is related to the manner of the error-function calculation. When the network is stimulated by the input signal  $p = (p_1, p_2, \dots, p_R)$  its response will be  $a = (a_1, a_2, \dots, a_n)$ , so that in the learning procedure the difference between this response and the required one should be minimized  $o = (o_1, o_2, \dots, o_s)$ . Depending on the manner of the error-function definition there are software proposals to calculate it in three ways:

1. "mse" - (Mean-squared error)
2. "msereg" - (Mean-squared error with regularization)
3. "sse" - (Sum-squared error)

There are three options offered for the selection of the transfer, i.e., activation function, so there is one linear and two sigmoid functions:

1. purelin (linear transfer function)
2. logsig (logarithmic sigmoid transfer function)
3. tansig (tangential sigmoid transfer function)

It is considered that the tansig function produces the best results in terms of the biggest number of concrete problems, and for that reason when selecting the transfer functions in the framework of the window, "Create new network" it is set as the "default".

Apart from these basic characteristics of neural networks, which are related first of all to the procedure of the training, it is necessary to define two more network parameters:

- the number of layers,
- the number of neurons in each of the layers.

The selection of the number of epochs is done following the selection of these parameters and starts the network training. The obtained output value for the defined synaptic weights and input values is brought to the network entry in order to make a potential correction of the mentioned coefficients and obtain the final output with a certain accuracy in the framework of the defined number of epochs. Obtaining the output once for all the input values and one set of placed weight coefficients represents an iteration, which is known as an epoch in the terminology of neural networks.

### 3 BACK-PROPAGATION NEURAL NETWORK (MEDIUM AIR)

Previously the significance of the request 4.3.1 was indicated, so in that respect the arbitrariness and the insufficient preciseness in the procedure of quantification of the aspects and

impacts on the environment favored by the standard ISO 14000 encouraged us to initiate research in this field on the basis of scientific methods and techniques. The objective of the research was to try to define, exactly in this part of analysis, the regularity in the quantification of the environmental impacts on the basis of data obtained from organizations that are certified in accordance with the requirements of standard ISO 14001, and to perform the application and checking on a new as well as certified organization by means of a generalization of the obtained results.

Taking into account that there is a very small number of certified organizations in Serbia and Montenegro in accordance with the standard ISO 14000 (28 in total) the first idea was to create a neural network on the basis of due diligence from all the organizations, which would then be trained to evaluate the significance of the impact in the new organization on the basis of such a large amount of input-output information and the different mathematic models. The data sought from the organizations were related to the register of all the identified aspects and the impacts on the environment and to their evaluation of the significance according to their own mathematical models. The organizations independently created and adjusted the mathematic models for the evaluation of the significance of the impact and the aspects on the environment to their criteria for meeting the requirements of the ISO 14001 standards.

However, due to impossibility of a cooperation with a larger number of organizations, data from four organizations were collected, so the training of the neural network was performed on the basis of data from three organizations, and the data from the fourth organization were used for the simulation of the model. Having in mind that in the course of due diligence from the certified organizations, the fields of activities of which are completely different, they bound themselves to respect the principle of absolute discretion and not to use any names or any organization's identity anywhere, we will use in the following text the letters A, B and C for the organizations, and the data will be analyzed to work out the new model, and D will be the letter for the organization whose data will be used for the simulation of the work of the model. As a lot of different data is in question (2184 impacts in total), pursuant to the recommendation of the standards we approached the classification

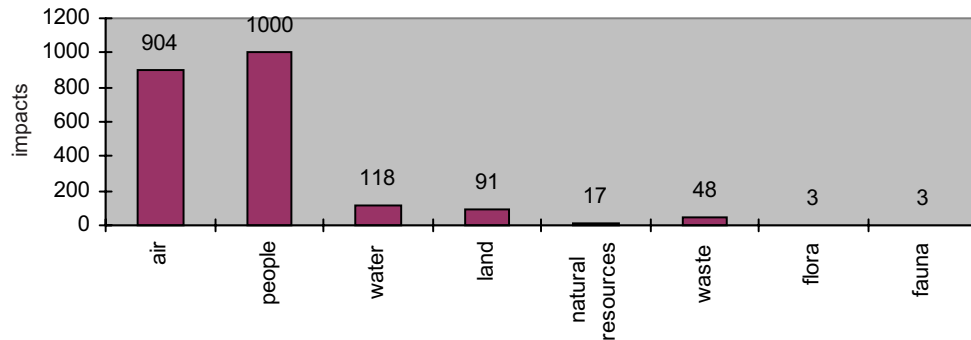

Fig. 6. Diagram of impacts number division according to the mediums of the effect

according to the medium on which the observed impacts have an effect:

- Air
- People
- Water
- Land
- Natural resources
- Waste
- Flora
- Fauna

The data schedule presented in Figure 6 is obtained by this procedure

As evaluations for all the three organizations (A, B and C) were obtained on the basis of different methodologies (mathematical models) it is necessary to perform a normalization of the input data in relation to the organization with the highest range of evaluations in order to harmonize the evaluation differences. The biggest range of evaluations is in organization A in relation to the criterion

“Environmental Impact Volume”, so that the evaluation is taken as a maximum, also for other organizations, and the relation of the evaluations among the criteria within the organizations, characteristic for its own mathematical model, aimed at a preservation of their particular quality, is kept in this process.

The procedure which will be presented for medium air, for which 904 inputs were obtained, is applied to other mediums, except for flora, fauna, waste and natural resources because the number of data in relation to flora, fauna and natural resources is very small, and as regards waste it is obtained from only one organization. Therefore, these impacts were not further considered, due to impossibility of obtaining real results.

The output values of the network (the final evaluation of the significance of impacts) are normalized in relation to the limitations set by the software package Matlab, and they are related to the allowed output width (-1, 1) so that all the

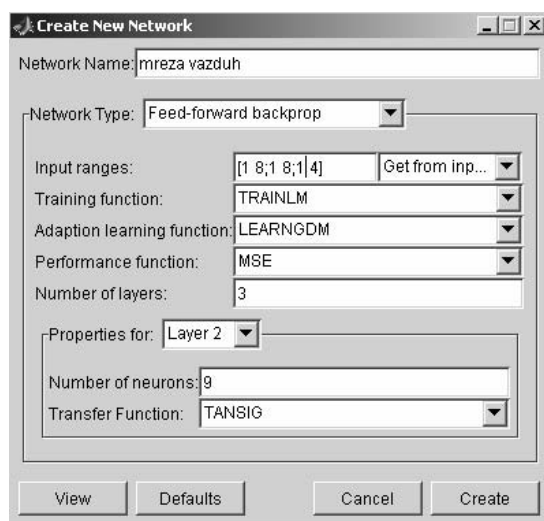

Fig. 7a. Performances of neural network

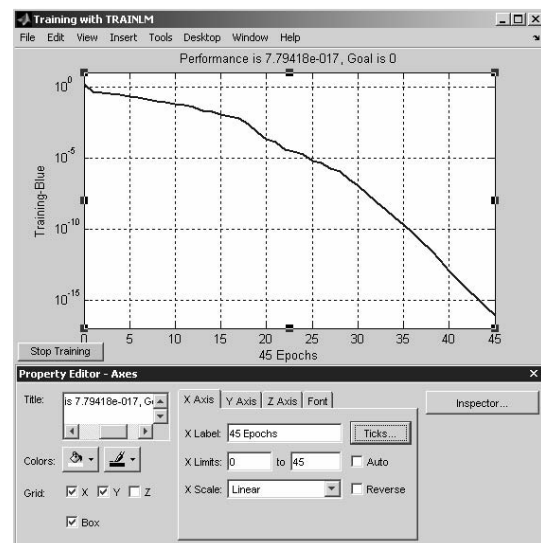

Fig. 7b. Convergence of neural network



significant impacts according to our own mathematical models were evaluated by evaluation 1 and those insignificant by -1. The performance of the selected back-propagation neural network for medium air is given in Figure 7a, and its convergence diagram, which defines speed and accuracy of training, in Figure 7b.

The appearance of the selected neural network with three layers, out of which the first two each have nine neurons, and the last output according to the rule 1 is presented in Figure 8.

After the results derived in this way, with a relatively fast convergence and a high accuracy, the model was tested with data from organization D, and produced results that completely coincided with the mathematical model of organization D, chosen from the four available models (models of organizations A, B, C and D) to serve as the reference model. The appearance of the basic window in Matlab with the results of the network training and the simulation

for the medium air is given in Figure 9.

Analogously with the previously defined procedure, we approached the neural-network creation and training for the medium people. The network that gave the best output results for the included evaluations of this environmental impact is the network with the characteristics given in Figure 10

The appearance of the selected neural network with three layers, out of which the first two have got 12 neurons and the last output 1, is presented in Figure 11

The accuracy of the network output for these performances is accomplished with  $10^{-15}$  in a total of 29 epochs. The appearance of the convergence diagram of the created neural network for the influence on the health of people is presented in Figure 12.

The network is tested analogously with the pervious procedure for the medium air using the data from organization D. The results of the simulation

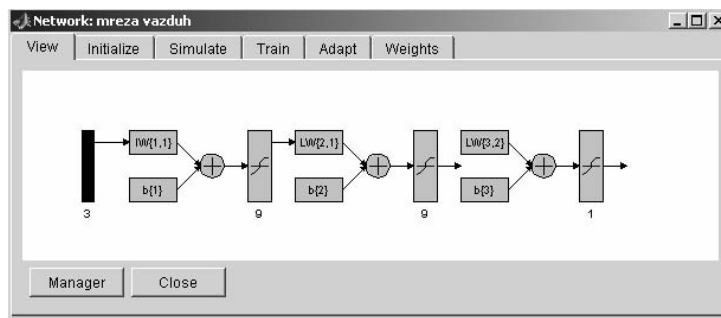

Fig. 8. Appearance of the neural network (air)

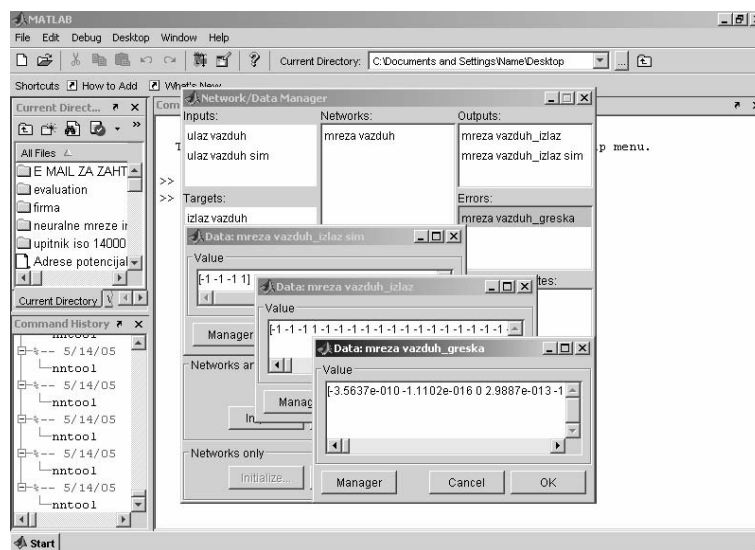

Fig. 9. Appearance of the basic window with results of the network training and simulation (air)

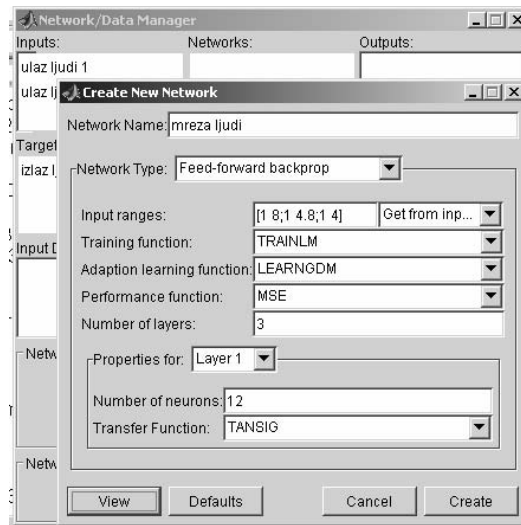

Fig. 10. Performances of neural network (people)

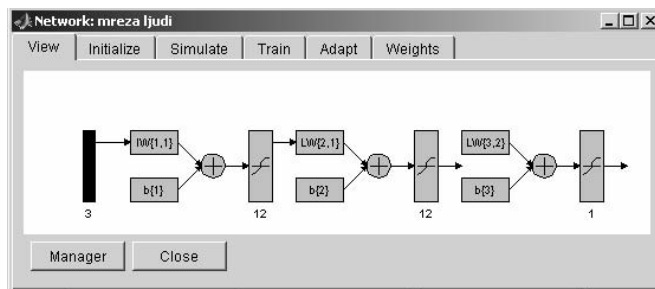

Fig. 11. Appearance of neural network (people)

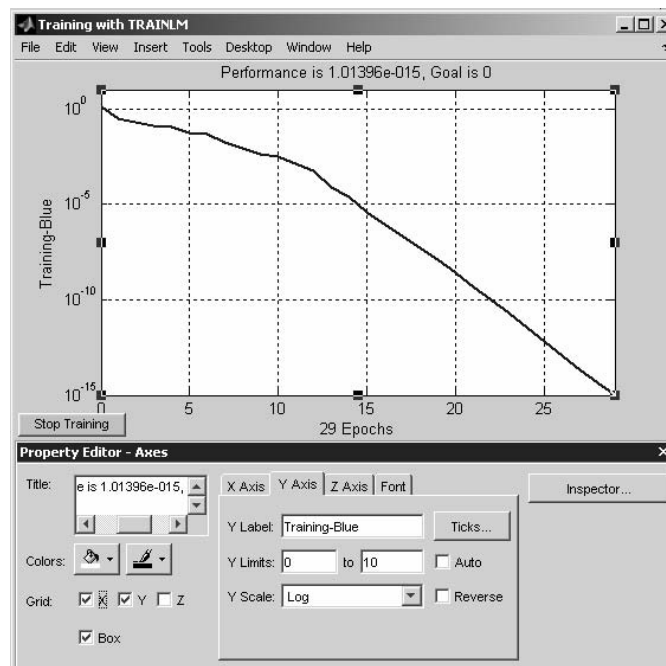

Fig. 12. Diagram of convergence of neural network (people)

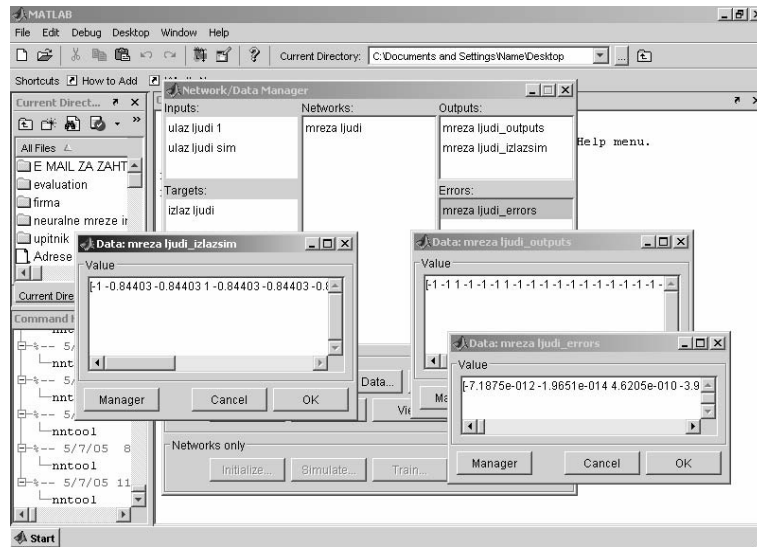

Fig. 13. Appearance of the basic window with results of network training and simulation (people)

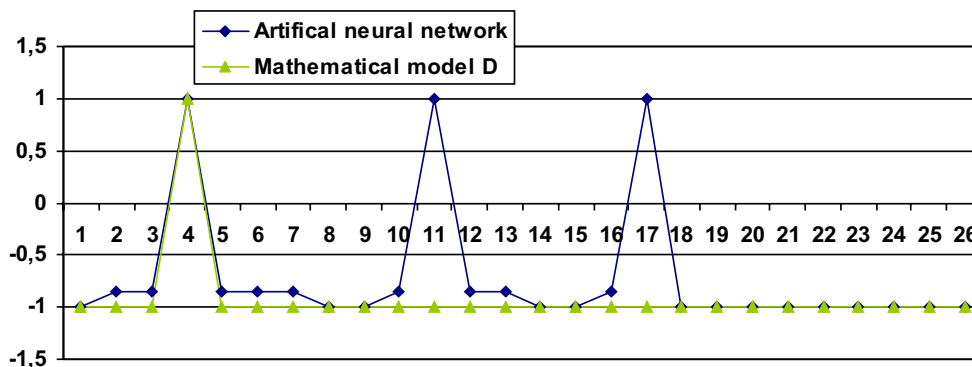

Fig. 14. Comparative analyses of the results for medium people

are presented in the Figure 13 within the window "Data: mreza ljudi\_izlazsim", and a certain deviation can be observed when compared to the data obtained by the methodology of organization D.

A comparative analysis of the results obtained by the neural network and the mathematical model of organization D are given in the diagram in Figure 14

The difference in the results obtained by the application of these two different models is the impact for 11 and 17. However, by an analysis of the mathematic model of organization D it can be seen that the impacts 11 and 17 belong to the limiting value that is not included as significant for the given model while the neural network acquires these data as significant. Therefore, it can be realized that the neural network, as regards the influence on health, is more sensitive about the significance of impact than the mathematical model of the organization D,

although the limiting values for each model as well as the neural network can be deemed as critical points due to the inexistence of recommendations of the standards or an exact analysis for their determination.

Taking into account a small training sample, the results that are obtained for the medium water and land showed a certain deviation in relation to the model of organization D.

#### 4 CONCLUSION

A comparative analysis of the available mathematical models and the obtained results through the application of a neural network has determined that the chosen back-propagation neural network gave satisfactory results for a sufficiently large training sample for the medium air and people. In particular, a reduction in the results for two samples out of a total of 26 for medium people is

negligible, considering that the evaluations of these impacts belong to the limited value of the mathematical model that certainly has to be a matter of dispute, and the model of the organization D itself in the part of the evaluation is certainly not perfect.

Satisfactory results for the mediums water and land were not obtained exactly because of the relatively small training sample, based on which the network was not able to produce the correct output.

The evident fact is that an evaluation like this, that itself has incorporated the specificities of available models from practice, has the highest character of objectivity and does not leave enough space for manipulations in the part of forming a register of significant impacts, and its efficiency and objectivity could be significantly improved through additional training of the neural network with innovated data.

## 5 REFERENCES

- [1] Jelena Jovanović (2005) Application of ICT on modeling of environmental aspects quantification, M.Sc thesis, *University of Podgorica, Faculty of Mechanical Engineering*, Podgorica.
- [2] Zdravko Krivokapić. School of quality – Managers of EMS, Book 1, *University of Podgorica, Faculty of Mechanical Engineering*, Podgorica.
- [3] Zdravko Krivokapić, Miodrag Bulatović. School of quality – Managers of EMS, Book 2, *University of Podgorica, Faculty of Mechanical Engineering*, Podgorica.
- [4] Milan Perović (1998) Management - informatics - quality, *CIM Center - Kragujevac*.
- [5] ISO 9000 for small business (1997) *What to do*, Beograd.
- [6] Poul Buch Jensen. Introduction to the ISO 14000 family of environmental management standards.
- [7] A. Wright, F.T. Allen. Environmental management system manual.
- [8] ISO 14001:2004 (2004) Environmental management systems – General guidelines on principles systems and support techniques, *ISO*.
- [9] ISO 14004:2004 (2004) Environmental management systems – General guidelines on principles systems and support techniques, *ISO*.
- [10] Demuth H., Beale M. (2000) Neural network toolbox - For Use with Matlab, *The MathWorks*.
- [11] Milenković S. (1997) Artificial neuron networks, *Foundation Andrejević*, Beograd.
- [12] Jocković, Ognjanović, Stankovski (1997) Artificial intelligence (Intelligent machines and systems), Beograd.

Authors' Address: Mag. Jelena Jovanović  
Prof. Dr. Zdravko Krivokapić  
University of Podgorica  
Faculty of Mechanical Eng.  
Cetinjski put bb  
81 000 Podgorica  
Montenegro

Prejeto: 22.11.2005  
Received:

Sprejeto: 23.2.2006  
Accepted:

Odrpto za diskusijo: 1 leto  
Open for discussion: 1 year