

ACTA ENTOMOLOGICA SLOVENICA

LJUBLJANA, MAY 1995

Vol. 3, No. 1: 43-48

PHYLOGENETIC RELATIONSHIPS OF THE BEE GENUS *DIOXYS* LEPELETIER & SERVILLE, 1825 (HYMENOPTERA: MEGACHILIDAE, MEGACHILINAE)

Andrej GOGALA
Ljubljana

Abstract – Phylogenetic analysis is made of several genera of Megachilinae using eleven adult characters. The genus *Dioxys* should be classified in its own tribe Dixini. Genera commonly placed in the tribe Osmiini should be included in the Megachilini.

Izvleček – Sorodstvena razmerja čebeljega rodu *Dioxys* Lepeletier & Serville, 1825 (Hymenoptera: Megachilidae, Megachilinae)

Narejena je filogenetska analiza več rodov poddružine Megachilinae z upoštevanjem enajst znakov odraslih osebkov. Rod *Dioxys* bi moral biti uvrščen v lasten tribus Dixini. Rodovi, ki jih navadno združujemo v tribus Osmiini, bi morali biti vključeni v tribus Megachilini.

Introduction

Species of the genus *Dioxys* Lepeletier & Serville, 1825 are cleptoparasitic and for this reason the older entomologists classified them together with other parasitic genera, especially *Coelioxys*. Species of *Coelioxys* are very similar to *Dioxys*, but this is the result of parallel evolution. Later, the genus *Dioxys* was included in Anthidiini. But because of many differences, a separate tribe was proposed for *Dioxys* (MICHENER, 1948). POPOV (1947) recognized a separate subfamily, Dioxynae. MAVROMOUSTAKIS (1968) also distinguished among Anthidiinae and Dioxynae. WINSTON (1979), in a comparative study of the proboscis, recognized *Dioxys* as a sister group to all the other Megachilinae. In spite of this, the genus *Dioxys* was included in the Anthidiini by ROIG-ALSINA & MICHENER (1993).

The genus *Dioxys* has a holarctic distribution. It was split into many genera by Popov and Mavromoustakis, but this was recognized as inappropriate by WARNCKE (1977).

In this study, the genus *Dioxys* is compared with other megachiline bees. It was found that it has many plesiomorphic character states, even more than the Lithurgini. If this is true, it would be the most primitive genus of the Megachilinae. It is interesting that the Nomadini, also a cleptoparasitic group, have the same position in Apidae (ROIG-ALSINA & MICHENER, 1993). Their closest relatives, collecting their own food for their progeny, had been obviously less successful than their modern successors, and became extinct. This did not happen to the cleptoparasitic species. Hosts of the Nomadini and species of the genus *Dioxys* are not closely related to their parasites as are the majority of hosts of other cleptoparasitic bees. If the genus *Dioxys* belonged to the tribe Anthidiini, it would be expected that its hosts would be from the same tribe. But this is not the case.

Taxa examined

Among the genus *Dioxys*, two species were examined: *D. tridentata* and *D. cincta*. The Lithurgini are represented by *Lithurgus chrysurus*, the Anthidiini are considered as a well defined group. Some genera commonly placed in Osmiini and Megachilini are treated separately. The genera *Hoplitis* and *Osmia* are recognized as treated by GOGALA (1995). Apart from observed characters, some data from ROIG-ALSINA & MICHENER (1993) were also used. If a character is represented in several states in the same group, only the state that is believed to be plesiomorphous for this group is considered.

List of characters

1. Supraclypeal area: 0) delimited by a sulcus directed toward inner margin of antennal socket (Fig. 1a); 1) delimited by subantennal suture directed toward outer margin of socket.

Subantennal suture is directed toward outer margin of socket only in Megachilinae. It is directed toward lower margin in most other bees, also in Fideliinae. In *Dioxys*, subantennal suture is directed toward outer margin of socket, but a sulcus arises from it and is directed toward inner margin of socket. The shape of supraclypeal area is therefore of the plesiomorphous type. Antennal sockets face forward, not sideward as in other Megachilinae.

2. Mandibular apex of female: 0) bifid; 1) tridentate with middle tooth longest; 2) tridentate or multidentate with lower tooth longest.

Bifid mandibles are present only in *Dioxys* (Fig. 1b). Other Megachilinae have at least tridentate mandibles, but third tooth in *Lithurgus* is not homologous with third tooth in others (ROIG-ALSINA & MICHENER, 1993).

3. Claws of female: 0) bifid; 1) simple.

4. Arolia: 0) present; 1) absent.

5. Membraneous outgrowths in laterodistal corners of clypeus: 0) present; 1) absent.

6. Preapical ridge of tergum 6 of male: 0) absent; 1) present.

This ridge has probably been lost in the majority of *Osmia*, and probably also in *Chelostoma* and *Hoplitis*, as it is present in closely related genera *Pseudoheriades* and *Hofferia*.

7. Nervulus of forewing: 0) interstitial or prefurcal; 1) interstitial or postfurcal.
 8. Horizontal basal zone of propodeum: 0) sharply delimited; 1) not evident.
 9. Transverse carina or sulcus of tergum 1: 0) present; 1) absent.
 10. Submarginal cells of forewing: 0) first cell longer than second; 1) cells of approximately equal length.

Fideliinae have three submarginal cells. In Megachilinae, the first transverse vein is lost (MICHENER, 1993). Thus, the first of the remaining two cells should be bigger. But this state is present only in *Lithurgus* and *Dioxys* (Fig. 1c). In other Megachilinae, the cells are equal.

11. Dististipital process: 0) absent; 1) present, curved anteriorly.

WINSTON (1979) reported that all Megachilinae except *Dioxys* have a dististipital process perpendicular to the distal end of the stipes, extending anteriorly. It is absent in Fideliinae.

Matrix of Character States

	12345678901
<i>Dioxys</i>	00010010000
<i>Lithurgus</i>	11110001101
Anthidiini	12000010011
Heriades	12100000011
Chelostoma	12100000111
Hoplitis	12100001111
<i>Osmia</i>	12101101011
<i>Megachile</i>	12111101011
<i>Coelioxys</i>	12111101011

Classificatory results

Some symplesiomorphies have been found among *Dioxys* and *Lithurgus*, but no reliable synapomorphies. Genus *Dioxys* should be placed in its own tribe Dioxini. Anthidiini share some important synapomorphies with Megachilini that are absent in *Dioxys*. Although *Dioxys* has been placed several times in Anthidiini, this is inappropriate.

Another result of this study is the proposed merger of Osmiini and Megachilini. The genera *Megachile* and *Coelioxys* are considered closely related to *Osmia*. Osmiini are, therefore, a paraphyletic group. This conclusion is confirmed also by Cladogram 5 in ROIG-ALSINA & MICHENER, 1993.

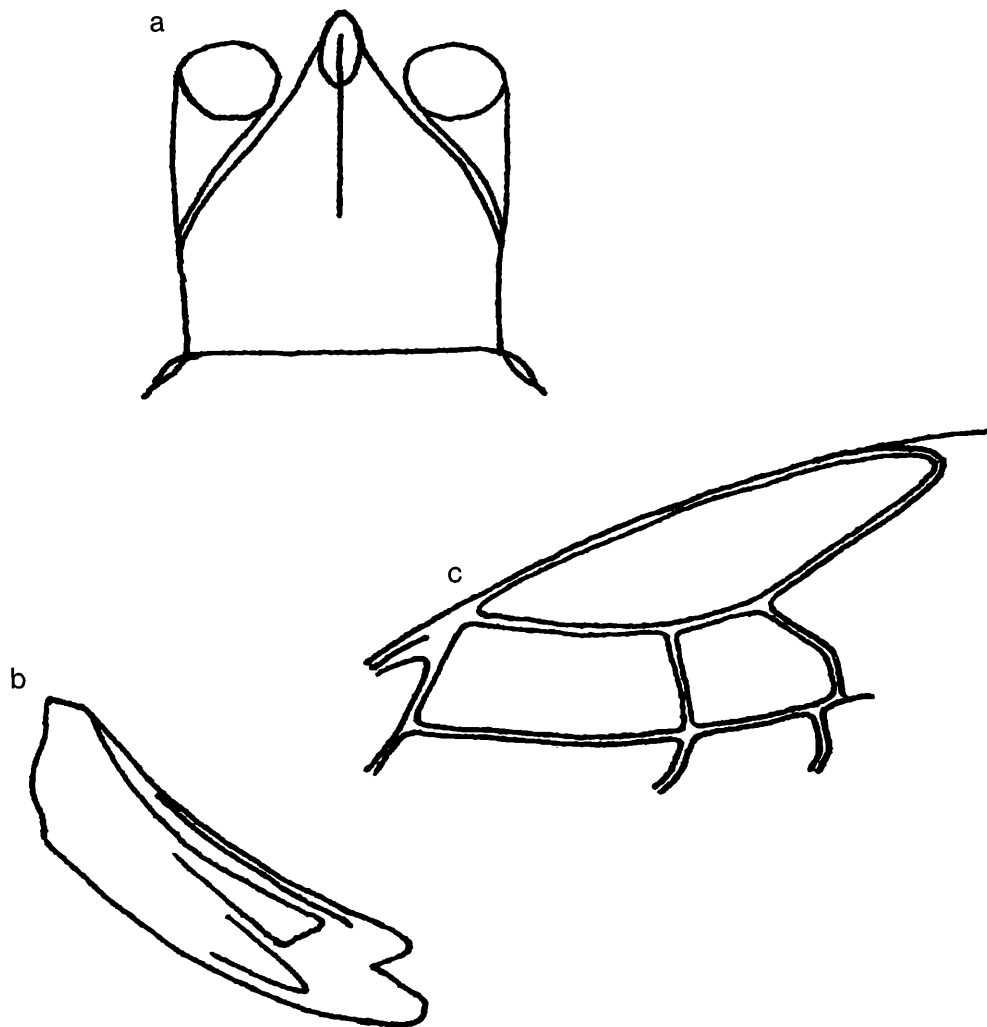

Fig.1: *Dioxys tridentata* (Nylander), a) supraclypeal area with antennal sockets (σ), b) mandible (ϱ), c) marginal and submarginal cells of forewing (σ).

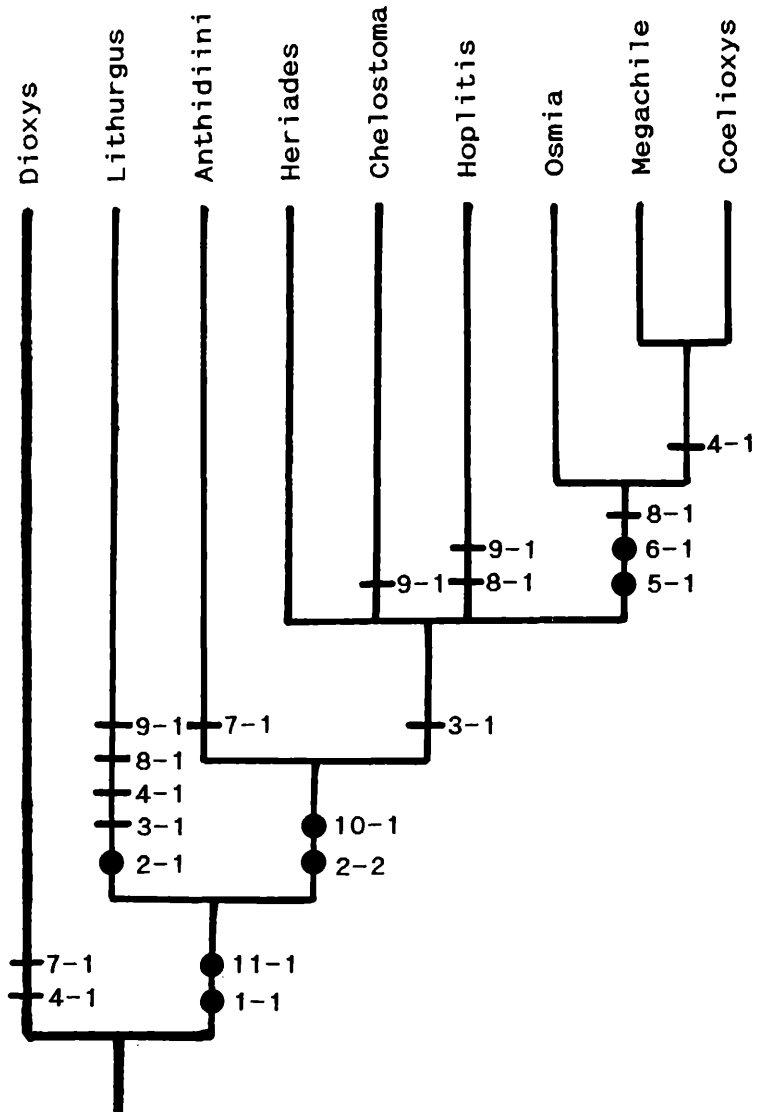

Fig. 2: Cladogram of Megachilinae, as based on characters examined in this study. Dots indicate character transformations that occur only once in the tree. Bars indicate changes that also occur in parallel elsewhere in the tree.

References

- Gogala, A.**, 1995: Partial generic revision of the bee tribe Osmiini (Hymenoptera: Megachilidae). *Acta entomol. slov.*, 3: 37-41.
- Mavromoustakis, G.A.**, 1968: New and little known bees of the family Megachilidae. *Boll. Mus. civ. Stor. nat. Venezia*, 18: 125-149.
- Michener, C.D.**, 1948: The generic classification of the Anthidiine bees. *Am. Mus. Novitates*, 1381: 1-29.
- Michener, C.D.**, 1993: Apoidea, Apiformes. In: Goulet, H., J.T. Huber [Eds]: *Hymenoptera of the world: an identification guide to families*. Canada Communication Group, Ottawa.
- Popov, V.B.**, 1947: Generic groupings of subfamily Dioxyinae. *Ent. Obozr.*, 1: 84-92.
- Roig-Alsina, A., C.D. Michener**, 1993: Studies of the phylogeny and classification of long-tongued bees. *Univ. Kansas Sci. Bull.*, 55(4): 124-162.
- Warncke, K.**, 1977: Beitrag zur Systematik der westpaläarktischen Bienengattung Dioxys. *Reichenbachia*, 16: 265-282.
- Winston, M.L.**, 1979: The proboscis of the long-tongued bees: a comparative study. *Univ. Kansas Sci. Bull.*, 51: 631-667.

Author's address/Naslov avtorja
Andrej GOGALA
Prirodoslovni muzej Slovenije
Prešernova 20, p.p. 290
SLO-61001 Ljubljana, Slovenia