

Modular Design and Its Application to Overhead Traveling Crane

Hong-Zhong Huang^{1,*} - Yanfeng Li¹ - Zhonglai Wang¹ - Li-Hua Xue² - Yong-Fu Wang²

¹ University of Electronic Science and Technology of China, School of Mechatronics Engineering, China

² Dalian University of Technology, School of Mechanical Engineering, China

In this paper, the method of modular design of a crane is presented. First, the main customer groups and their expectations of the new product are confirmed. Then, the main function of the new product is decomposed into smaller function modules. Based on these function modules, the relativity of function modules is analyzed and quantified. By the entropy method, the best scheme is selected through the evaluation of design, manufacture, assembly and maintenance, etc. Finally, a product platform is set up by analyzing the degree of influence of the function modules on customer needs. The storage format of a function module and the structure of the function module database are also investigated. The function of a model is set as the keyword in the function model database, and a module-selecting algorithm based on fuzzy pattern recognition is developed. The validity of the modular design method presented is verified by the design of an overhead traveling crane.

© 2009 Journal of Mechanical Engineering. All rights reserved.

Keywords: modular design, product planning, function decomposition, similarity theory, overhead traveling crane

0 INTRODUCTION

A modern mechanical system often consists of power modules, transmission modules, execution modules, computer modules and control modules. As traditionally, products are designed and manufactured individually according to design requirements, the overall performance of the products may not be satisfactory. This leads to difficulties in maintenance, because function components are hard to change or upgrade. Modular design is a method proposed by Occident in the 1950's. The method mainly solves the conflicts between types, specifications, design cycles, and cost. In short, modular design is such a method that standardizes the connecting sizes of congeneric components that fulfill certain functions. These components can be interchanged easily, so it is convenient to replace and change the assemblies. The purpose of this method is to improve the design efficiency and to make the design experience transferred and inherited. The evident advantages of this method are not only the satisfied customer needs, but also the shortened design cycle and reduced development cost. The method therefore, ensures the enterprises to be competitive in the market.

In 1900, a German company designed the so-called "ideal bookshelf" with modular

principles. In this design, the bookshelf was decomposed into a base locator, shelf and upper plate. There are several shelves with different sizes. A customer could select different shelves to build up an "ideal bookshelf" according to his or her specific requirements. An "Ideal bookshelf" is one of the earliest products that were designed according to modular design. Afterwards, the idea and the theory of modular design was studied further and applied by scholars and engineers into every aspect of life. The theory of modular design has been evolving gradually. Around 1920, the modular principles began to be applied in the design of mechanical products in Europe, especially in Germany. In the 1950's, after a great deal of exploration, modular design was formally and systematically practiced as an advanced design method by Euro-American experts. With the improvements of the theory and techniques, modular design is generally used in the development of all kinds of products.

Research on modular design is still progressing, and the theory of modular design continues to be enriched. For example, many researchers like Huang, Peter, Liang and Kusiak, are studying the object-oriented modular design [1] to [5]. Mok et al. [6] have also made much progress in the modularization of products. Combined with life cycle theory, research on the modular design of products has been conducted

*Corr. Author's Address: School of Mechatronics Engineering, University of Electronic Science and Technology of China, Chengdu, Sichuan, 611731, China, hzhuang@uestc.edu.cn

by Gu et al. [7]. From a different angle, Tong views modular design as a system problem. He believes that modular design is an integrated process where modular systems are set up and modules are combined to build up a product system through module decomposition and combination. He concludes that modularization is a superior form to standardization [8].

Many Chinese scholars have done considerable studies on modular design. For example, Xu et al. work on the modular design of numerically-controlled machine ([9] and [10]). Their contribution is the generalized modularization system and flexible modular system. Wang and Chen have developed the machine center using the method of modular design [11]. The theory of modular design has been used to develop the main drive system of the numerically-controlled machine center by Deng and Wang [12]. Wang et al. applies the method of modular design to the design of product families [13].

The focus of this work is to apply the method of modular design to crane design. The whole system and components of a crane are traditionally designed according to the main parameters and performance requirements. The use of some function components in span product series is seldom considered and therefore, the universal performance of components is not satisfied, since due to a lack of idea of standardization, experience is difficult to transfer and accumulate. Because the developing cycle can be shortened, the developing pace can be expedited, the cost can be lowered, new techniques can be employed, the manufacturing management is convenient and the modular design of a crane has been developed greatly.

This paper is organized as follows. Section 1 illustrates the method of modular design. The product specification of the modular design is discussed in Section 2. The definition of customer groups and the planning of product families according to customer group requirements has been investigated. The construction and evaluation of a module system are discussed in Section 3. The establishment of module databases and the storage structure of modules are discussed in Section 4. In Section 5, with the example of the design of an overhead traveling crane, the validity and usability of the proposed method of modular design is verified. Section 6 concludes this paper with discussions of future work.

1 METHOD OF MODULAR DESIGN

1.1 Concepts of Modular Design

1.1.1 Relevant Concepts [14]

(1) **Product series:** A group of products with the same functionality, similar structure and manufacturing process and different performance parameters.

(2) **Classification of product series:** Product series can be classified into vertical, parallel and whole product series.

(3) **Vertical product series:** A group of products with the same functionality, similar structure and manufacturing process, but different sizes and different major performances.

(4) **Parallel product series:** A group of products with the same performances or power, but different relationships between the main performances through only interchanging some executable components with the same kind of functions and different performance parameters.

(5) **Whole product series:** A group of product series by adding or changing some function modules of the vertical product series. They therefore, consist of both vertical product series and parallel product series.

(6) **Product families:** A product family consists of products that share a common product platform but have specific features and functionality to satisfy different sets of customers.

From the above concepts, it is obvious that product series with the same overall functionality and different performances are formed through the combination of various function modules with different sizes.

Corresponding to the above definitions, modular products can be classified into vertical product series, parallel product series and span product series. Modular design can be classified into modular design of parallel product series, vertical product series and span product series.

One process of modular design is to abstract functions and construct modules according to the requirements. The other process is to select a group of modules rationally to constitute a product scheme.

We define modular design as: Determine function modules of a product family through the requirement analysis and function decomposition. Construct the product platform of the product family through the relativity analysis of the

function modules. Form the vertical, parallel, and span product series through adding auxiliary function modules and supporting function modules.

1.2 Classification of Function Modules

Function modules help implement technical functions independently or are combined with other functions. Product modules are designed independently of their functions and are based only on production-based considerations. Function modules are classified as basic, auxiliary, adaptive, special, and non-modules in [1] and [15].

Basic functions do not vary in principle and are fundamental to a product. A basic function can fulfill an overall function by itself or in combination with other functions. A basic module is a module implementing basic functions [15].

Auxiliary functions are complementary and task-specific sub-functions that need not appear in all overall function variants. An auxiliary module corresponds to auxiliary functions that are used in conjunction with the basic modules to create various products.

Adaptive functions are necessary for the adaptation to other systems and to marginal conditions. An adaptive module is a module in which adaptive functions are implemented. Adaptive functions adapt a part or a system to other products or systems. Adaptive modules handle unpredictable constraints.

Special function modules are specific complementary sub-function modules, which correspond to basic function modules and are required by the development of new products. Special function modules are only designed to perform special functions required by some products.

Customer-specific functions not provided in the modular system will recur even in most careful development. A non-module implements customer-specific functions that do occur even in most careful design development. Non-modules have to be designed individually for specific tasks to satisfy customer needs.

1.3 Principles of Modular Design

The modular design consists of product planning, general layout and function analysis, feasibility evaluation and the design of modular structure. The design of modular structure

belongs to detailed design, which is beyond the scope of this paper.

The product types will be specified at first in the design of product series or product families. The main contents of the specifications are the investigation and analysis of market requirements, the identification of product series, the analysis of parameter ranges and the determination of main parameters.

The general layout of products is a general scheme of a group of products acquired through modular design, which includes main functions and structure features and further responds to the market requirements [16].

According to the coverage form and the extent of modular products in product series, the layout scheme is classified into the vertical, parallel, span, and whole series, etc.

The product will be broken down into several modules at first when modular design is implemented. The design will continue with modules as basic units. The main action of the function analysis is to decompose the overall product function, to determine the correlation degree between function modules, and to reassemble function modules back in order to form the entire modular systems.

In essence, the product can be classified in arbitrary levels to form modules. When determining the decomposition schemes of modules many factors such as design, assembly, maintenance and cost, etc. should be taken into account.

Function analysis includes the following two aspects: the function decomposition and the clustering of function modules.

Function decomposition specifies the overall functions of a product. The sub-functions that are required to perform the overall functions can be acquired. These sub-functions can be divided gradually until every sub-function has corresponding physical modules.

The clustering of function modules determines the relativity between function modules and the form correlation matrices of function modules. Based on evaluation criteria, a group of schemes can be selected as the final concept.

The design and manufacture complexity of modules increases with the decreased number of modules. But the assembly and maintenance complexity of products increases with the number of modules. Therefore, an optimal number of modules may exist.

In modular design, every module partition scheme constitutes a system; and the information entropy about assembly, maintenance and cost exists in this system. Therefore, the algorithm entropy can be used to measure the complexity in [17] to [19].

An important feature of modular design is that function modules are convenient to interchange, which not only requires the connecting factors in connecting site to be consistent, but also requires that the performance of the whole machine does not decrease after the modules are changed. To meet these requirements, the key of modular design is to identify the relativity between modules, to construct the consistency of module interfaces and to build module structures by physical similarity principles [16].

2 PRODUCT PLANNING

Product planning includes the definition of product requirements, the development of product families and the construction of the modular system. In this section, the definition of product requirements and the development of product families are discussed.

2.1 Product Series Planning of Modular Design

A product family is a collection of a series of products that share universal core components. They can meet multi-market and multi-customer needs through simple modifications or variations.

The planning of product families includes the following hierarchies [20]:

1. **Definition of product requirements:** Acquiring function and parameter requirements through the analysis of customer needs and constructing the function structure of product.

2. **Definition of a product series:** In terms of function and parameter requirements, specifying the proper product series parameters and function ranges, and identifying the product series spectrum.

3. **Definition of a flexible module series:** According to the product series spectrum, the planning of a flexible modular series can be performed. This mainly includes the partition of modules, the planning of module series, the construction of modules, the normalization and serialization of components, the planning and construction of modular structures, and similarly.

Product requirements are the expression of customer needs. Product series and module series are the expression of design. The planning and the construction of the elements of product can be completed from defining product series to defining module series. The enlargement of product families is performed through the mapping from product series to module series.

2.2 Definition of Generalized Modular Products

The definition of products generally represents normalized information of customer needs and all kinds of technical information needed in the design process. An exact definition of products is the foundation of enterprises to make strategies of product development, which is the basis and source of product design. For generalized modular design, the definition of products can be understood as follows. On one hand, it is the classification process of customer groups based on customer needs while on the other hand, the parameter specification ranges of products can be identified rationally in terms of customer needs and the structural design of products. Fig. 1 [20] describes the process of the definition of a generalized modular product.

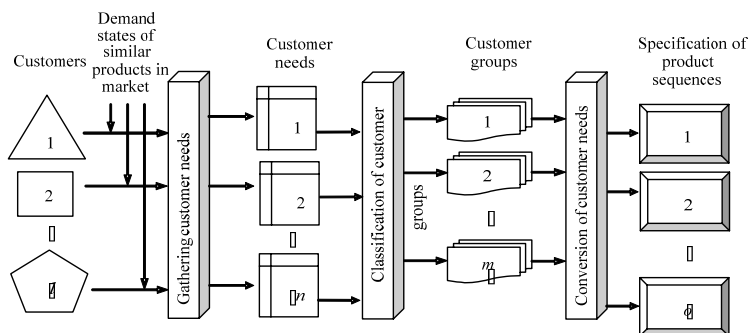

Fig. 1. Product definition of modular design

2.2.1 Acquisition and Analysis of Customer Needs

Enterprises should gather raw data from customers through as many approaches and kinds of investigation as possible. The main ways to gather customer needs are as follows [22]. Acquiring the past and present customer needs by analyzing the order forms in the past two or three years. Acquiring the product value increment needs of customers by investigating and analyzing customer needs, and acquiring the potential customer needs indirectly. Acquiring the trend of future customer needs and other information by analyzing the effects of new techniques, new materials, the new manufacturing process, environment and zoology balance, etc. Acquiring the possible customer needs by analyzing economical and political situations.

The main way of gathering customer needs is market investigation. The main content of market investigation is illustrated in [16] in detail. Moreover, the investigation and analysis of other factories that produce same or similar products should be conducted.

2.2.2 Data Analysis of Customer Needs

After the raw data of customer needs are gathered, they need to be further generalized and interpreted on the premise of not distorting customer wills. Customer needs with the same or similar meanings will be incorporated.

From the point of view of life cycle, customer needs consist of four elements: customer consultation, product purchase, product use and product abandonment and recovery. Fig.

2 depicts the classification tree of generalized customer needs based on life cycle [23].

2.2.3 Mapping From Customer Needs to Function Modules

After customer needs are gathered and customer groups are classified, customer needs can be ranked according to the importance of customer groups. After the investigation of customer needs and the classification of customer groups, the matrix of customer groups and customer needs can be identified as

$$S = \begin{bmatrix} S_{11} & S_{12} & \cdots & S_{1n} \\ S_{21} & S_{22} & \cdots & S_{2n} \\ \vdots & \vdots & \vdots & \vdots \\ S_{m1} & S_{m2} & \cdots & S_{mn} \end{bmatrix} \quad (1)$$

where s_{ij} is the requirement degree of the i^{th} customer group to the j^{th} customer need.

Let the weights of customer groups be $W = [w_1, w_2, \dots, w_m]$. (2)

By synthesizing customer needs, the weighted vector of customer group needs is

$$U = W \times S \quad (3)$$

As shown in Fig. 3 [24], after the weighted vector of customer group needs is acquired, quality function deployment is used to describe the product groups-oriented relation between customer group needs and function modules. There are many approaches to realize the mapping between customer group needs and function modules. They are chosen according to different situations [25].

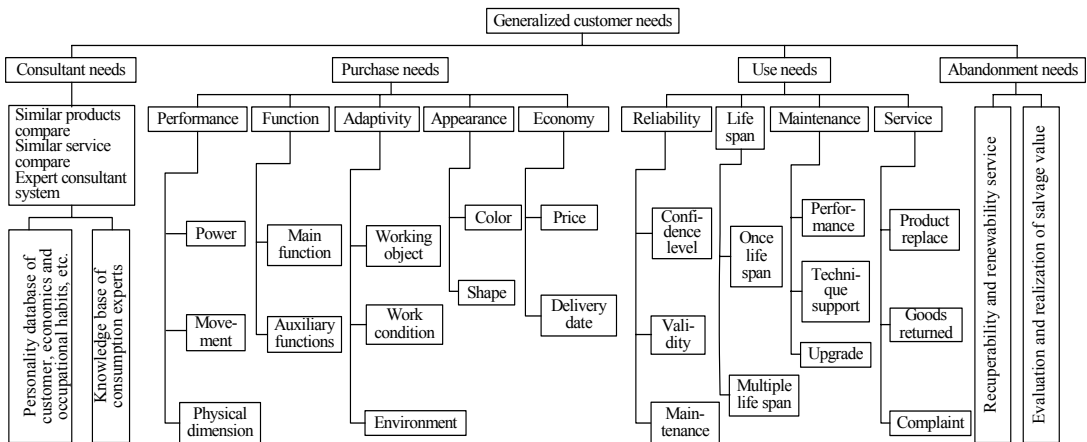

Fig. 2. Tree of generalized customer needs

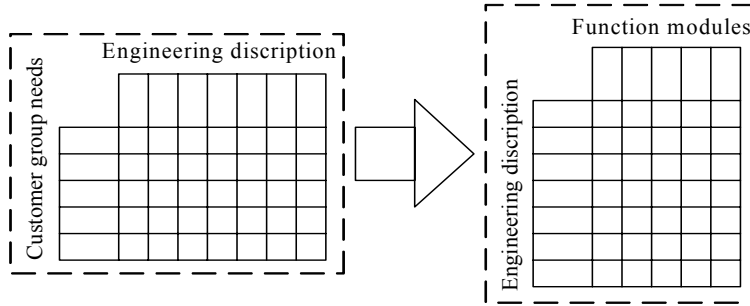

Fig. 3. Mapping between customer group needs and function modules

According to the structural features of products, customer group needs, function module needs of products and the range of parameter specification can be identified through qualitative analysis and quantitative comparison.

2.3 Definition of Modular Product Series

A generalized modular product model is a parameterized model consisting of flexible modules from which a group of products with different parameters can be derived. Therefore, the emphasis of planning generalized product series is to analyze the main parameters that influence structural design. By analyzing the relation between functions, structures and parameters, a parameter that affects the whole design can mostly be selected as the basis to classify product series. And other main parameters are used to further perform the planning of module series.

2.3.1 Similarity Laws and Preferred Number Series

Geometric similarity is widely accepted because of its simplicity. However, technical artifacts stepped up in geometric proportions are not satisfactory except in very rare cases. In modular design, similarity laws are usually the evaluation criteria.

We talk about similarity if the relationship of at least one physical quantity in the basic and sequential designs is constant. It is possible to define basic similarities with the help of fundamental quantities, such as length, time, force, quantity of electricity, temperature and luminous intensity (Table 1) [15].

Thus, there is geometric similarity if the ratio of the length of any sequential design to all the lengths of the basic design is constant. Here, the non-dimensional parameter to be held constant is $\varphi_L = L_1/L_0$, where L_1 is any length of the first member of the size range (sequential design); and L_0 is the corresponding length of the basic design. In the same way, we can describe similarities in time, force, electricity, temperature and luminous intensity.

Table 1. Basic similarities

Similarity	Basic quantity	Invariants
Geometric	Length	$\varphi_L = L_1/L_0$
Temporal	Time	$\varphi_t = t_1/t_0$
Force	Force	$\varphi_F = F_1/F_0$
Electrical	Charge	$\varphi_Q = Q_1/Q_0$
Thermal	Temperature	$\varphi_T = T_1/T_0$
Photometric	Luminous intensity	$\varphi_B = B_1/B_0$

The definitions of kinematic, static, dynamic and thermal similarities are introduced in [15] in detail. Moreover, some important similarity relationships in the development of product series are illustrated and the matters that need special attention in similar design are also given.

After similarity relationships are identified to the vertical series modular products, the next task is to choose the individual steps of a size range. Practice has shown that the 10-step method is suitable for geometric scaling.

Table 2. Main values of preferred numbers

Basic series				Basic series				Basic series				Basic series				Basic series			
R5	R10	R20	R40	R5	R10	R20	R40	R5	R10	R20	R40	R5	R10	R20	R40	R5	R10	R20	R40
1.00	1.00	1.00	1.00	1.60	1.60	1.60	1.60	2.50	2.50	2.50	2.50	4.00	4.00	4.00	4.00	6.30	6.30	6.30	6.30
			1.06				1.70				2.65				4.25				6.70
		1.12	1.12			1.80	1.80			2.80	2.80			4.50	4.50			7.10	7.10
			1.18				1.90				3.00				4.75				7.50
	1.25	1.25	1.25		2.00	2.00	2.00		3.15	3.15	3.15		5.00	5.00	5.00		8.00	8.00	8.00
			1.32				2.12				3.35				5.30				8.50
		1.40	1.40				2.24			3.55	3.55			5.60	5.60			9.00	9.00
			1.50				2.36				3.75				6.00				9.50

A decimal-geometric progression is based on multiplication by a constant factor φ and is developed within one decade. The constant factor φ determines the step sizes of the series and can be expressed as:

$$\varphi = \sqrt[\varepsilon]{a_\varepsilon / a_0} = \sqrt[\varepsilon]{10} \quad (4)$$

where ε is the number of steps within a decade.

For the 10 steps, the series would then have a factor: $\varphi = \sqrt[10]{10} = 1.25$ and is called R10. The number of terms in the series is $z = \varepsilon + 1$.

The need for geometric scaling is often found in daily life and also in technical practice. The resulting series conform with the Weber-Fechner law which states that the physiological sensation produced by a stimulus is proportional to the logarithm of the stimulus. Table 2 identifies the main values of preferred numbers.

2.3.2 Analysis of Parameter Ranges and Identification of Main Parameters

The product parameters can be classified into size, kinematical and dynamic parameters.

Size parameters denote those for sizes, such as the key sizes of structure, the relative sizes associated with product use and installation sizes, etc. Kinematical parameters denote the velocity of moving components, such as the number of revolutions and the feeding speed of the main bearing in machine tools, the number of revolutions of electrical fans and the highest speed of automobiles, etc. Dynamic parameters are those for power, torque, pressure and voltage, etc.

The main parameters are those that express the main performances and specifications of

products, such as the processing temperature of CPUs, the size of computers or TV display, the largest machining diameters, the power of electric bulbs, the volume of refrigerators, and so on. The main product parameters should be determined at the same time with the design of product series. In the design of products series, the main parameters of different specifications will be ranked according to geometric progression. Identifying the main parameters according to geometric progression is the most rational scheme which meets extensive needs with less specification.

Apart from the main parameters, the identification of other basic parameters is fulfilled with the use of geometric progression, approximate geometric progression or hybrid common-ratio progression. There are many series of relations existing in like parameters of different product specifications.

3 CONSTRUCTION AND EVALUATION OF MODULAR SYSTEM

In this section, the construction and evaluation of a modular system will be discussed in detail, and then the establishment of product platform will be introduced.

3.1 Construction of Modular System

The construction of a modular system consists of the following two sections. One is the general layout of modular systems, viz. the classification of modules according to product functions and structure characteristics. The other one is the detailed construction of modular systems, which belongs to detailed design and will not be discussed here.

3.1.1 Module Classification

When modular design is performed, the customer needs can be divided into several modules and then these modules will be the basic units to continue the design. Therefore, the rationality of module classification has an important influence on the quality, appearance, generality and cost of products. There are many ways to decompose modules [26]. From different points of view of function, structure ([27] and [28]), there are different classification methods. The rationality of module classification is the foundation and the key to evaluate modular design. So all the effects of life cycle must be taken into consideration [7] and [17].

3.1.2 Analysis of Conventional Function

Function analysis is the basis of module classification. The modules designed according to the modular idea will have one or several functions. When all the modules are aggregated together, these modules must cooperate to fulfill the overall function.

According to function analysis, the product will be generally divided into several units, viz. function modules. These function modules will fulfill the overall function.

3.1.3 Principles of Module Classification

The division of modules can follow these basic rules [16] and [14]:

1. Decomposition of function units. The classification degree of function units can be determined by customer needs of the product development and the results of the technical and economic analysis.
2. Independence of function units. The decomposed function units need to be as independent as possible. Such modules are easy to be consolidated and composed to constitute many types of derivative products.
3. Modularity of parts. The popular module type is parts. The structure and performance of modules is decided by customer needs and economy.
4. Modularity of components. Some components in parts can be further modularized after a detailed function decomposition. The components will be of different purposes and performances by

replacing some accessories, which are more economical and flexible than changing all the parts. So component modularity is a module type worthy of emphasis.

5. Modularity of basic units. Sometimes, basic units are the main parts of mechanical products. The purpose of their modularity is to enlarge the working space of products and to enable the specification of products to have the possibility of change on the premise of ensuring rigidity.

3.1.4 Function Analysis Based on Function Modules

The conventional methods of function analysis can not provide the optimal degree of function decomposition, which results in the highest design efficiency and economic effectiveness. We therefore, propose an improved function analysis method based on function modules.

In the process of function decomposition, if one of the following conditions is satisfied, the module will be viewed as an independent module [29].

1. Heredity: The carrier of sub-function can be utilized by the next generation products.
2. Technical innovation: Implementation techniques of sub-functions can be substituted by new techniques in the product life cycle.
3. Change of plan: Sub-functions are characteristic carriers changed with plans.
4. Technical parameters: Sub-functions embody changeable technical parameters.
5. Pattern: The form and color of sub-function carriers will change with the social fashion.
6. General units: The sub-functions with the same carrier in all products.
7. Process/Organization: As independent modules, sub-functions can be organized and produced individually or have a special production cycle.
8. Separate experiment: The functions and performances of sub-functions can be tested separately.
9. Independent currency: Sub-functions can circulate through market as a "black box" independently.
10. Maintenance: As independent modules, sub-functions are convenient to maintain.
11. Upgrade: If the upgrade is foreseeable, sub-functions are easy to upgrade.

12. Recovery: The materials of sub-function carriers are polluted and retrievable.

The top-down method is used to perform function decomposition until all the functions of customer needs can be decomposed into sub-functions. If no proper sub-function modules can be found to fulfill some sub-functions, the new sub-function modules will be defined and added to the function module base by designers.

Fig. 4 illustrates the decomposition process of sub-functions. Where GF denotes the general function, SF denotes sub-functions.

For the function modules that do not satisfy the conditions of independent module, the relation between sub-functions and customer group needs can be established indirectly through identifying the corresponding sub-functions and customer group needs.

The correlation degree between sub-function modules identified according to the decomposition of function modules can be classified into two types: relevance and irrelevance. If the sub-function SF2 consists of the sub-functions SF21 and SF22, the correlation degree between SF21 and SF22 is 5. The correlation degree between sub-function and itself is also 5. Therefore, the diagonal elements of the correlation matrix are all 5.

The geometric and physical correlation can be further identified. Geometric correlation

denotes the precision requirements of two modules in static position or relative motion locus. The identification of geometric correlation can start with size relation, verticality, parallelism and coaxiality.

The evaluation principles of geometric correlation between two sub-functions are constructed as in Table 3.

Physical correlation means that physical relations exist between two modules, such as the transmission of energy flow, information flow and material flow, etc. Energy flow means that the driving force, torque, movement, electric current and hydraulic pressure are transferred between modules. The function of energy flow bears the acting force or drives executive components to perform certain action and fulfill special functions. Information flow denotes the transmission of light and electricity between modules.

The evaluation rules of physical correlation between two sub-functions are constructed as in Table 4.

Sub-correlation matrix A_i ($i = 1, 2, 3, \dots, k, k+1, k+2$) of N sub-functions can be constructed with the reference to the function and assembly structure of products acquired from function analysis, where A_{k+1} is the geometric correlation matrices, and A_{k+2} is the physical correlation matrices.

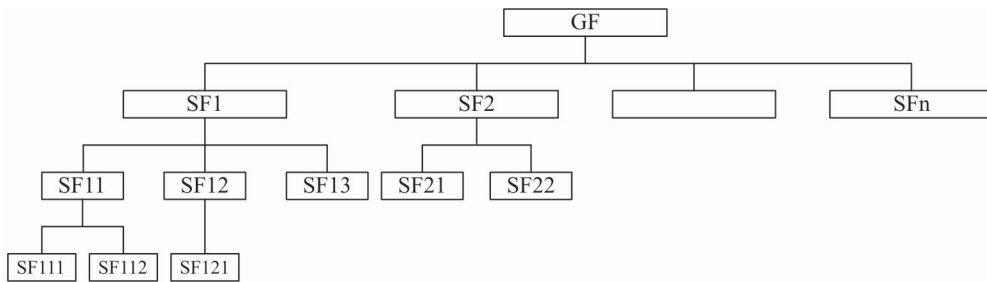

Fig. 4. Function decomposition

Table 3. Geometric correlation degree

Description	Correlation degree
Strict verticality, parallelism and coaxiality exist between each other	5
Geometric correlation only exists between one and another sub-function, which is determined according to precision requirements	1-4
No geometric correlation	0

$$A_i = [a_{pq,i}] = \begin{bmatrix} 3 & 2 & \dots & 2 \\ 1 & 0 & \dots & 0 \\ \vdots & \vdots & \vdots & \vdots \\ 2 & 4 & \dots & 0 \end{bmatrix} \quad i=1,2,\dots,k,k+1,k+2 \quad (5)$$

$$a_{pq,i} \in \{1,2,3,4,5,0\}, p, q = 1,2,\dots,N \quad (6)$$

where N is the number of sub-functions in new products.

Table 4: Physical correlation degree

Description	Correlation degree
Physical correlation of energy flow	5
Physical correlation of information flow	3-4
Physical correlation of material flow	1-2
No physical correlation	0

In terms of sub-correlation matrices A_i , the correlation matrices of sub-function module $R = [r_{pq}]$ are generated as follows ([10] and [17]).

$$r_{pq} = \begin{cases} \beta \left(\mu_1 \sum_{i=1}^k w_i a_{pq,i} + \mu_2 a_{pq,k+1} + \mu_3 a_{pq,k+2} \right), & p \neq q \\ 1, & p = q \end{cases} \quad (7)$$

where β is the regularization coefficient. To ensure $r_{pq} \in \{0, 1\}$, let $\beta = 0.2$, μ_1 be the weight of customer group needs, μ_2 be the weight of geometric correlation rules, μ_3 be the weight of physical correlation rules, and w_i be the weight of i th customer group.

The analytic hierarchy process (AHP) can be used to identify μ_1 , μ_2 and μ_3 ([19] and [30]). The identification of w_i was discussed in Section 2.

3.2 Evaluation of Module Decomposition Scheme

Each module decomposition scheme constitutes a system in which information entropy (also called system complexity) exists in design, manufacture, assembly, maintenance and cost. Based on this point of view, the realization of a modular system is determined by the complexity, viz. information entropy. The smaller the complexity, the more rational the module decomposition scheme [18] and [24].

3.2.1 Complexity of Design and Manufacture

The more the function characteristics are integrated in a module, the more complicated the interior structure is and the more difficult the design and manufacture is, and vice versa. The definition of the complexity of design and manufacture is:

$$H_p(a) = -\frac{1}{k_a} \sum_{i=1}^N [p_i \ln p_i + (1-p_i) \ln(1-p_i)] \quad (8)$$

where a is the granularity of modules, k_a is the number of modules corresponding to the granularity of modules a , N is the number of sub-functions required by products, p_i is the determinate degree of the i th function in design and manufacture, and $p_i \in [0, 1]$. If $p_i = 1$, the function is definite completely. If $p_i = 0$, the function is not definite completely.

3.2.2 Assembly

The smaller the granularity, and the greater the number of modules k_a , the more assembly relations are identified, the longer the assembly time, and the assembly difficulty will increase, and vice versa. The definition of the assembly complexity is:

$$H_a(a) = -\sum_{j=1}^{k_a} \frac{n_l(j)}{n} \ln \frac{n_l(j)}{n} \quad (9)$$

where $n(j)$ is the number of modules to compose the j th module.

3.2.3 Cost

From the point of view of cost, during the process of function decomposition, the sub-function modules with high cost and additional value will be isolated to form different function modules. So during product maintenance, if one of the modules fails, only the failed one needs to be replaced; hence the maintenance cost can be reduced. As a whole, the average information entropy of cost should be decreased. The cost complexity is defined as

$$H_c(a) = -\frac{1}{k_a} \sum_{i=1}^n (c_{ri} \ln c_{ri} + (1-c_{ri}) \ln(1-c_{ri})) \quad (10)$$

where c_{ri} is the relative cost of the i th sub-function and can be determined by AHP method.

3.2.4 Maintenance

The vulnerable sub-function modules should be separated. Therefore, the products are prone to be subdivided under the consideration of maintenance. As a whole, the average information entropy in maintenance should be decreased. The definition of maintenance complexity is

$$H_m(a) = -\frac{1}{k_a} \sum_{i=1}^n (\eta_i \ln \eta_i + (1-\eta_i) \ln(1-\eta_i)) \quad (11)$$

where η_i is the relative vulnerable probability (relative damage vulnerability) of the i^{th} sub-function module and can be determined with AHP method.

3.2.5 Synthetic Evaluation

Normalize the assembly, cost and maintenance complexity as follows [17] and [30]:

$$\bar{H}_p(a_i) = \frac{H_p(a_i)}{\sum_{i=1}^M H_p(a_i)} \quad (12)$$

$$\bar{H}_a(a_i) = \frac{H_a(a_i)}{\sum_{i=1}^M H_a(a_i)} \quad (13)$$

$$\bar{H}_c(a_i) = \frac{H_c(a_i)}{\sum_{i=1}^M H_c(a_i)} \quad (14)$$

$$\bar{H}_m(a_i) = \frac{H_m(a_i)}{\sum_{i=1}^M H_m(a_i)} \quad (15)$$

where M is the number of module decomposition schemes. $H_a(a_i)$, $H_c(a_i)$ and $H_m(a_i)$ are the assembly, cost and maintenance complexity, respectively. They are decided by the granularity of module a_i ($i = 1, 2, \dots, M$).

According to the complexities after the normalization, the model of unconstrained optimization is given by:

$$\min \{ \bar{H}(a) = \bar{H}_p(a) + \bar{H}_a(a) + \bar{H}_c(a) + \bar{H}_m(a) \}$$

All the possible granularities of module a_i can be acquired from the definition of module granularity. If e is the number that makes $H(a_e)$ smallest, then the corresponding module decomposition scheme is optimal.

3.3 Construction of Product Family Platform

For a product family, the product platform is a fixed and universal product core that can

support the development and manufacture of product family by adding some function modules and corresponding constraint conditions. The construction of the product platform through the mathematical description is illustrated below [13].

Let K be the ultimate number of modules determined in modular system, m the customer group needs and $W = \{w_1, w_2, \dots, w_m\}$ the weight of customer group needs. The matrix F that describes the influence of the change of the requirements to function modules can be constructed as follows.

$$F = \begin{bmatrix} & R_1 & R_2 & \dots & R_m \\ M_1 & 1 & 0 & \dots & 0 \\ M_2 & 1 & 1 & \dots & 0 \\ \vdots & \vdots & \vdots & \dots & \vdots \\ M_K & 0 & 0 & \dots & 0 \end{bmatrix} \quad (16)$$

where R_i ($i = 1, 2, \dots, m$) is customer needs. M_j ($j = 1, 2, \dots, K$) are modules. For example, if the change of R_1 influences M_1 , the number in crossing point of R_1 and M_1 is 1, which ensures the influence of R_i on M_j to be identified easily. Suppose that the influence matrix of function changes on modules is E , then

$$E = W \cdot F. \quad (17)$$

According to the functional principle diagram of product family, the number of connections between one module and others can be confirmed. Counting the connecting number c_i of Module M_i and other modules to form Convex $C = [c_i]$. Let

$$P = [p_i] = E + C \quad (18)$$

where p_i reflects the influence of Module M_i on the whole product family. The bigger p_i is, the higher the influence of the function module on the product family and the more closely the function module combines with the product family. Associated with the importance of function modules, the modules can be rearranged. The first function modules after rearranging can be confirmed as the product platform.

4 DATA MANAGEMENT

A module database is used to store module data, which are the working achievements in the process of module construction. The module

database is also the basis of customization [31]. Therefore, the module database is the medium to relate the construction of function modules to redesign in modular design.

Module management can be divided into design management and production management. The main purpose of design management is to utilize the current modules adequately to fulfil rational combinations, and make them satisfy the actual customers needs quickly and effectively. Moreover, if the current module combinations do not satisfy the customer needs, the determining indicating information can be presented to design departments through design management, such as which modules need to be designed and modified, etc. The main purposes of production management are the decomposition and summary of modules, the statistics of materials and the print of all kinds of summary sheets, and so on.

In this section, the encoding and storage of modules, the structure of module database of design management are discussed and the module index mechanism based on fuzzy pattern recognition is set up.

4.1 Module Encoding

Module encoding mainly reflects the function of modules and the features of correlative connections and interfaces. The rules of module encoding are uniqueness, extendibility, adaptability, implication, stability, identity, manipulability, brevity and format unification [32].

The encoding rules will affect designers to recognize the modules and to name the newly developed function modules. To adapt to the encoding rules of modules, an encoding rule of 9-bit codes is adopted in this section.

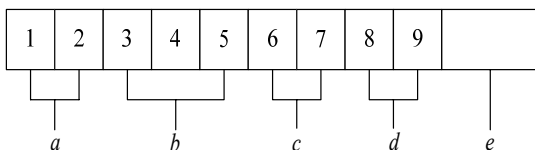

Fig. 5. 9-bit codes

In Fig. 5, *a* represents the primary recognition codes, which are the abbreviations of function module names and are used to identify the types of function modules. *b* contains the primary parameter codes, which are the main

function parameters. *c* consists of the interface type codes. Different encoding of interface types corresponds to different interface types. *d* is the design edition codes, which are the design series of modules and indicate the number of module modifications. *e* is the additional codes, which are used to illustrate other important information of modules.

In the process of module encoding, the 9 bit code must be complete. When the number in a bit is empty, the 0 will be used to fill-up. Additional codes can be added behind the encodement, which are some additional information of modules. The length of additional codes is confined within 7 bits.

4.2 Storage of Module Data

The storage of module data means to store module data, construct the module database with certain structure and organization. The storage thus makes the management and utilization of modules more convenient. The key of accessing data with high efficiency is the encoding of modules, the organized form of module data and the structure of the module database.

4.2.1 Data Structure of Single Module

The storage structure of modules is different from ordinary components, which not only describes the information of function structure, performance and management of the module itself, but also expresses all the attributes and methods relevant to the module manipulation.

The main information expressed by the storage structure of modules is as follows [33]: the management, structure, composition, interface and performance information of modules.

All kinds of information should be stored in different data sub-modules according to types, which is beneficial in decreasing the recognition number in the index process of modules.

4.2.2 Construction of Module Database

The purpose of constructing the module database is to organize and manage function modules better. Based on this point of view, the

module database with the organization of function is adopted. For the function modules fulfilling the same function, they can be further managed systematically according to the basic realization principles of module function or they can be constructed directly and stored in the same function table. There can be different realization methods to the same function but the different realization methods must correspond to different structures and performances and should generate different function modules. In the early development stage of new product series, viz. conceptual design, all the constructed module databases are function structure models of product system [15].

4.2.3 Additional Information Tables in Database

The main parameter and interface of modules are designed according to the idea of serialization or product family in the module database. So the mapping method can be used to encode modules, which can simplify the encoding of modules. But after this mapping is adopted, the corresponding additional information tables in module database must be established.

In terms of the process of constructing the module database system, the required additional information tables include the interface definition table, main parameter definition table, etc. If other information is needed in the construction of module database system, the corresponding additional tables must be established.

4.3 Index of Module Database

In the computer-aided modular design of new products, the algorithm of module selection is very important. Much research on the algorithms has been conducted ([10] and [34]). An algorithm of module selection based on fuzzy pattern recognition is presented in this section.

4.3.1 Module Selection Policy

In the development of new products, after the requirements of a function module is proposed, the designer will index the module database to find whether the existing function modules can satisfy the current design requirements. Fig. 7 is the detailed flow chart of module selection.

4.3.2 Module Index Based on Fuzzy Pattern Recognition

Let $R = \{r_1, r_2, r_3, \dots, r_m, r_{m+1}, \dots, r_{m+n}\}$ be a group of attributes of a design module, where r_i ($i = 1, 2, 3, \dots, m$) are structure attributes and r_{m+j} ($j = 1, 2, 3, \dots, n$) are the function attributes. Suppose that $D = \{d_1, d_2, d_3, \dots, d_m, d_{m+1}, \dots, d_{m+n}\}$ is the set of design requirement parameters and $L = \{l_1, l_2, l_3, \dots, l_m, l_{m+1}, \dots, l_{m+n}\}$ is the set of module parameters in module database.

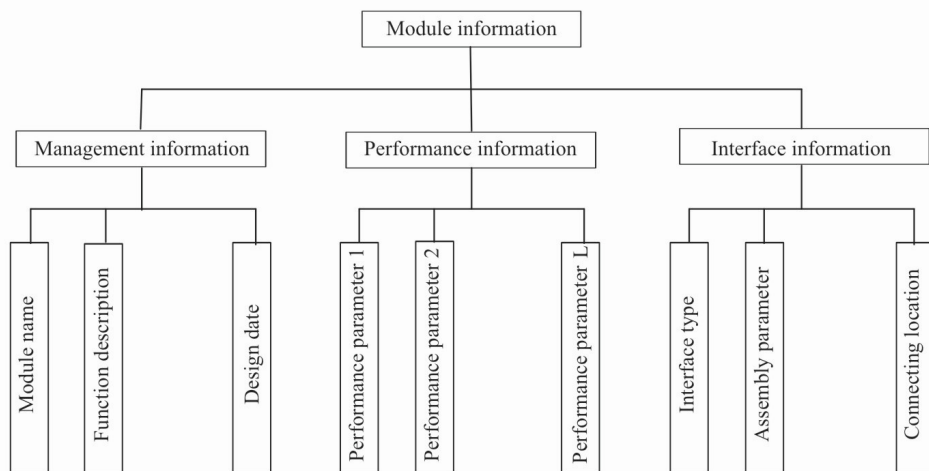

Fig. 6. Storing framework of a function module

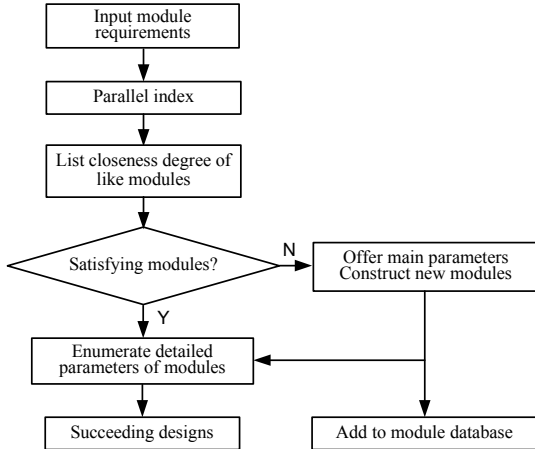

Fig. 7. Flow chart of module selection

A normal membership function is constructed as follows:

$$\mu_{\tilde{B}}(u_i) = e^{-\left(\frac{d_i - l_i}{b_i}\right)^2} \quad (20)$$

where d_i and l_i are the module requirement parameter and the parameter of existing modules in module database, respectively. b_i is constant corresponding to the parameter, which expresses the acceptance error of the parameter.

Each recognition object (modules in module database) corresponding to a requirement module is a fuzzy set and can be expressed as

$$\tilde{B} = (\mu_{\tilde{B}}(u_1), \mu_{\tilde{B}}(u_2), \dots, \mu_{\tilde{B}}(u_{m+n})) \quad (21)$$

where $\mu_{\tilde{B}}(u_i)$ denotes the membership degree of an attribute parameter to the requirement module attribute of the identification object.

The correspondence between the module to be designed and itself is a fuzzy set.

$$\tilde{A} = (\mu_{\tilde{A}}(u_1), \mu_{\tilde{A}}(u_2), \dots, \mu_{\tilde{A}}(u_{m+n})) \quad (22)$$

It is obvious that the module to be designed is completely same as itself. So all the elements of \tilde{A} are 1.

The closeness degree of two sets can be calculated by employing lattice closeness degree [16]. Because the importance of every module attribute and the corresponding weights are different, in this paper, the least weighted arithmetic mean method is used to calculate closeness degree.

Let $W = \{w_1, w_2, w_3, \dots, w_{m+n}\}$ be the weight of module attributes. The closeness degree is given by

$$N(\tilde{A}, \tilde{B}) = \frac{\sum_{i=1}^{m+n} w_i (\mu_{\tilde{A}}(u_i) \wedge \mu_{\tilde{B}}(u_i))}{\frac{1}{2} \sum_{i=1}^{m+n} w_i (\mu_{\tilde{A}}(u_i) + \mu_{\tilde{B}}(u_i))} \quad (23)$$

After the closeness degrees of design modules and current modules in module database are acquired, the designer can select the module with the largest closeness degree or modify the existing module data or design requirements to meet design needs on the basis of the module with the largest closeness degree.

5 MODULAR DESIGN OF DOUBLE-GIRDER OVERHEAD TRAVELING CRANE

An overhead traveling crane is an extensively used hoisting and transportation machine. It is a kind of bridge crane that moves in three dimensions. It has many advantages, such as large carrying capacity, high reliability, and simple manufacturing processes, etc.

Based on the method of modular design discussed above, two aspects are addressed in this section: First, the product family planning and function decomposition of the overhead traveling crane is performed; second, the results are evaluated from assemblies, designs and manufacturing processes.

5.1 Identification of Crane

The technical parameters determine the working ability of the crane and are the basis of the crane design [35]. The main technical parameters of the overhead traveling crane are lifting capacity Q , lifting height H , working speed of mechanism V , group classification code, etc.

5.1.1 Lifting Capacity

The maximum lifting capacity of the crane is called the rated lifting capacity. The rated lifting capacity of overhead traveling crane is constant. Table 5 shows the series of maximum lifting capacity defined by the ISO 2374. These numbers are for all types of cranes.

5.1.2 Lifting Height

The lifting height of the overhead traveling crane is the vertical distance from the ground to the maximum lifting position of load handling device. The lifting height is decided by the

working requirements. If there are no special requirements, the lifting height can be simply determined according to a design standard, e.g. the national standard of China GB 791-65 (Table 6).

5.1.3 Crane Span

The horizontal distance between the crane rail centers is called crane span L . The crane span of overhead travelling crane should be less than the workplace span. Table 7 is the crane span series suggested by GB 790-65.

5.1.4 Working Speed

Working speeds of a crane include main lifting speed, auxiliary lifting speed, trolley travelling speed and crane traversing speed. The actual working speeds are decided according to

working requirements. Working speeds can be identified according to Table 8.

5.1.5 Group Classification

The group classification of cranes is the basis of the steel structure and mechanism design. It provides a reference range to users and manufacturers. Table 9 is the group classification of overhead travelling cranes suggested by GB 3811-83.

5.2 Traditional Structure Decomposition of the Overhead Travelling Crane

According to the traditional design, the overhead travelling crane consists of the following sections: electric control, trolley, crane travelling and bridge. Fig. 8 is a detailed decomposition of traditional overhead travelling crane.

Table 5. Maximum lifting capacity series (t)

0.1	0.125	0.16	0.2	0.25	0.32	0.4	0.5	0.63
0.8	1	1.25	1.6	2	2.5	3.2	4	5
6.3	8	10	(11.2)	12.5	(14)	16	(18)	20
(22.5)	25	(28)	32	(36)	(40)	(45)	50	(56)
63	(71)	80	(90)	100	(112)	125	(140)	160
(180)	200	(225)	250	(280)	320	(360)	400	(450)
500	(560)	630	(710)	800	(900)	1000		

Table 6. Lifting height series of overhead travelling crane (GB 791-65)

Lifting capacity Q		3-50		80		100		125		160		200		250	
Lifting height H	Main hook	12	16	20	30	20	30	20	30	24	30	19	30	16	30
	Auxiliary hook	14	18	22	32	22	32	22	32	26	32	21	32	18	32

Table 7. Crane span series of overhead travelling crane (GB 790-65)

Workplace span		9	12	15	18	21	24	27	30	33	36
Crane span L	$Q = 3-50$ t	7.5	10.5	13.5	16.5	19.5	22.5	25.5	28.5	31.5	-
		7	10	13	16	19	22	25	28	31	-
	$Q = 80-250$ t	-	-	-	16	19	22	25	28	31	34

Table 8. Rated working speed of cranes

Crane types		Lifting speed (m/s)		Crane travel speed (m/s)	
		Main	Auxiliary	Trolley	Crane
General-purpose overhead travelling crane with hook	A1, A2	0.016 - 0.05	0.133 - 0.166	0.166 - 0.332	0.05 - 0.667
	A3, A4	0.033 - 0.2	0.133 - 0.332	0.332 - 0.667	0.667 - 1.5
	A5, A6	0.133 - 0.332	0.3 - 0.332	0.667 - 0.833	1.167 - 2
Overhead travelling crane with magnet		0.3 - 0.332	0.332 - 0.416	0.667 - 0.833	1.667 - 2
Overhead travelling crane with grab		0.667 - 0.833		0.667 - 0.833	1.667 - 2

Table 9. Group classification of overhead travelling cranes (GB3811-83)

Hooks	Application situation		Group classification	
	Instalment and maintenance of power		A1-A3	
	Shop and warehouse		A3-A5	
	Heavy duty, Shop and warehouse		A6-A7	

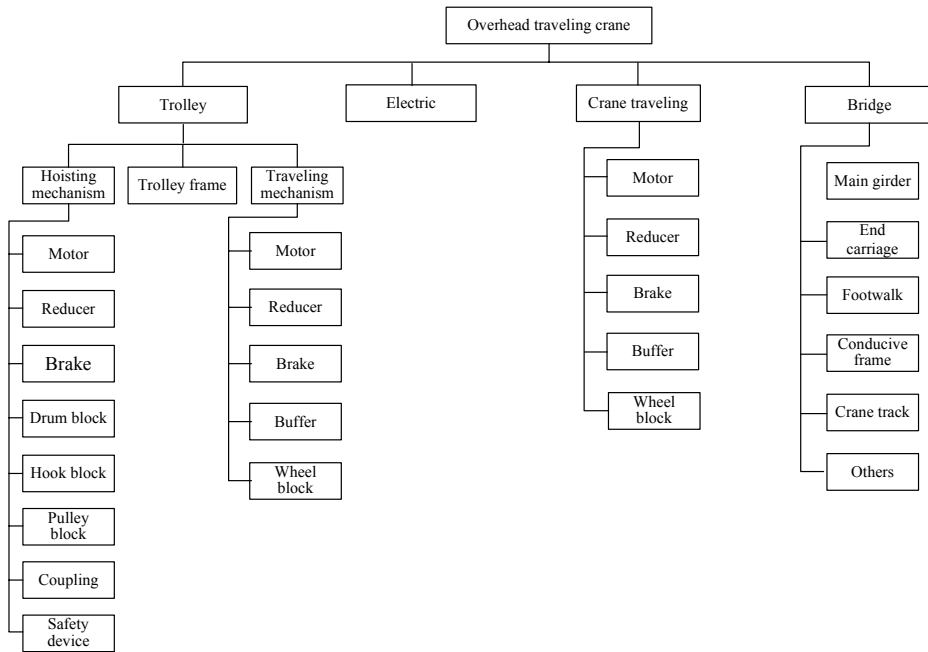

Fig. 8. Structure decomposition of traditional overhead travelling crane

From Fig. 8, it is obvious that the traditional design process of the overhead travelling crane contains the idea of modular design. However, the idea of modular design does not carry out completely, and the following problems exist in traditional design:

1. Since the sizes of components are not in the same order of magnitudes, the design workload and complexities for components are different and some components are difficult to be integrated.

2. The connectivity among components is not high, and it is hard to achieve standardization and serialization.

3. The connections of components are complicated and are not beneficial to manufacturing and maintenance.

4. The exchangeability of components is weak.

The traditional design method of cranes does not meet the market requirements. In this section, the modular design is employed to the design of overhead travelling crane.

5.3 Function Decomposition of Overhead Travelling cranes

The main function of the overhead travelling crane is to safely and reliably move materials with a certain speed from one place to another. This process is performed under the action of control information within the specified field.

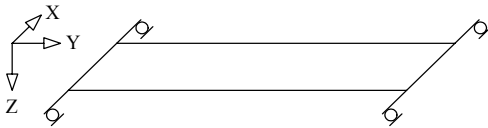

Fig. 9. Diagram of double-girder bridge

In the three-dimension coordinates of Fig. 9, Axis X represents the length of the workplace, Axis Y represents the width of the workplace, Axis Z represents the lifting direction. According to the working cycle of the overhead travelling crane, the carrying function is performed by the following three basic actions: moving along the horizontal X and Y directions and moving along the vertical Z direction. The realization of the load handling function depends on certain tools.

According to the working cycle diagram, the overall function of the overhead travelling crane can be divided into two sub-functions, viz. the movement along the horizontal axes X and Y and the movement along the vertical axis Z. Compared with the traditional structure diagram, the function carriers of these sub-functions can be found. The horizontal movement along X is realized by the crane travel module, the horizontal movement along Y is fulfilled by the trolley and the vertical movement along Z is accomplished by the lifting mechanism.

In order to realize the horizontal movement, the realization form can be divided into pull-type and self-propelled type according to different types of power. The pull-type does not have a power source and the movement can be fulfilled by corresponding components. Self-propelled type completes the horizontal movement by combining the driving function, transmission function, control function and working function into a system.

Among them, the driving function can be performed by a motor, hydraulic motor, etc. The transmission function is used to transfer torque and change speed to meet the requirements of

working components. It can be further decomposed into the speed-reducing function, force-transfer function and coupling function i.e. a speed reducer, transmission shaft and coupling. The control function is used to control the beginning and the end of horizontal movements. The brake function can change the state of objects from moving to stationary. The travelling function can be fulfilled by wheels and other components.

The vertical movement is lifting the loads up and down. The function of the crane is to transport heavy materials. In the process of horizontal movement, the vertical direction will undergo suspending heavy materials, which is an important function to be fulfilled by the crane. In the fulfilling process of this function, safety and reliability are very important.

The decomposition of driving function, transmission function and control function is similar to the decomposition of horizontal movement function. The working function will be further decomposed into load handling, reducing force and lifting function. The brake function is used to suspend heavy objects. The protect function will be divided into limiting position and limiting force functions, which are used to limit the height and weight, respectively.

Through function decomposition, we can find that the double-girder overhead travelling crane consists of five modules of Class II, sixteen modules of Class III and six modules of Class IV (Table 10).

According to the realization principle of function modules, the modules of the overhead travelling crane can be classified into the following types: the supporting function module, driving function module, controlling function module, braking function module, working function module, reducing function module, coupling function module, transferring function module, lifting function module, reducing force function module, limiting position function module and limiting force function module.

5.4 Function Module Classification

5.4.1 Identification of Correlation Degree Between Functions

1. Function relativity determined by main parameters

For the overhead travelling crane, the customized parameters include lifting capacity Q ,

Table 10. *Function modules of overhead travelling crane*

Class II	Support (I), Support (II), Brake (DR _U), Control (CON _{U+}), Brake (B _U)
Class III	Drive (DR _X), Control (CON _X), Working (W _X), Brake (B _X) Drive (DR _Y), Control (CON _Y), Working (W _Y), Brake (B _Y) Reduce speed (RB _U), Coupling (COU _U), Transfer force (TF _U), Lifting (RI _U), Reduce force (DB _U), Load handling (S _U), Limit position (LP _U), Limit force (LF _U)
Class IV	Reduce speed (RB _X), Transfer force (TF _X), Coupling (COU _X) Reduce speed (RB _Y), Transfer force (TF _Y), Coupling (COU _Y)

Table 11. *All classification schemes of function modules*

Threshold	Design complexity	Regularization	Assembly complexity	Regularization	Overall complexity
1.0000	1.0000	0.0409	3.2958	0.1042	0.1451
0.8566	1.1674	0.0478	3.1738	0.1003	0.1481
0.7232	1.3827	0.0566	3.1224	0.0987	0.1553
0.7222	1.3846	0.0566	3.0711	0.0971	0.1537
0.6818	1.4667	0.0600	3.0004	0.0949	0.1549
0.5789	1.7275	0.0707	2.6535	0.0839	0.1546
0.5334	1.8748	0.0767	2.5702	0.0813	0.1580
0.5272	1.8967	0.0776	2.4456	0.0773	0.1549
0.4950	2.0202	0.0826	1.9673	0.0622	0.1448
0.4684	2.1349	0.0873	2.0406	0.0645	0.1518
0.4036	2.4777	0.1014	1.7157	0.0542	0.1556
0.3710	2.6954	0.1103	1.3827	0.0437	0.1540
0.3108	3.2175	0.1316	1.1899	0.0376	0.1692

function 12 of the horizontal movement along Axis Y are independent function modules.

Functions 14, 15, 16, 3, 5, 17, 18, 19, 21 are combined to form the lifting function module.

Functions 6, 9, 22, 23, 24 are combined to form independent horizontal movement along the Axis X.

Functions 10, 13, 25, 26, 27 are combined to form independent horizontal movement along the Axis Y.

6 CONCLUSIONS AND FUTURE WORK

The method of modular design is mainly discussed in this paper. This method has been applied in the design of an overhead travelling crane. Promising results are obtained.

Our main research work is as follows:

1. The design methodology is introduced into the modular design.
2. The acquisition of customer needs and the

classification of customer groups in the process of modular design are studied.

3. The construction process, methods and the theoretical knowledge of modular system are investigated.

4. The proposed method has been successfully applied to the design of the overhead travelling crane by accounting for the design characteristics of the overhead travelling crane.

Methods of modular design will continue to advance with technical innovations, and there are many challenging research issues to be solved [37]. Examples of the future research work include:

1. Improve the theory of generalized modular design [38].
2. Explore the construction method of flexible platforms of product families.
3. Investigate virtual modular design.
4. Integrate collaborative design and concurrent design with modular design.

5. Apply modular design widely to practical engineering design.

7 ACKNOWLEDGEMENT

This research is partially supported by the National Natural Science Foundation of China under the contract number 50775026, and the Specialized Research Fund for the Doctoral Program of Higher Education of China under the contract number 20060614016. Constructive suggestions and comments from the referees and editors are very much appreciated. The authors would also like to acknowledge constructive revision suggestions and help by Dr. Christopher Hoyle, Department of Mechanical Engineering, Northwestern University, USA.

8 REFERENCES

- [1] Huang, C.C. (2000) Overview of modular product development. *Proceedings of the National Science Council, ROC (A)*, vol. 24, no. 3, p. 149-165.
- [2] Peter, O.G., Liang, W.Y. (1998) An object oriented approach to design with modules. *Computer Integrated Systems*, vol. 11, no. 4, p. 267-283.
- [3] Peter, O.G., Liang, W.Y. (2001) OODS: An object-oriented design system – an example of electronics assemblies. *Internet Lab Technical Report TR, 02*.
- [4] Kusiak, A., Huang, C.C. (1996) Development of modular products. *IEEE Transactions on Components, Packaging and Manufacturing Technology-Part A*, vol. 19, no. 4, p. 523-537.
- [5] Huang, C.C., Kusiak, A. (1998) Modularity in design of products and systems. *IEEE Transactions on Systems, Man and Cybernetics Part A: System and Humans*, vol. 28, no. 1, p. 66-77.
- [6] Mok, H.S., Yang, T.I., Moon, K.S., etc. (2000) Modularization of a product. *Proceedings of the 5th Annual International Conference on Industrial Engineering-Theory, Applications and Practice*. Hsinchu, Taiwan, p. 1-5.
- [7] Gu, P., Sosale, S. (1999) Product modularization for life cycle engineering. *Robotics and Computer Integrated Manufacturing*, 15, p. 387-401.
- [8] Tong, S.Z. (1997) The implementary ways of modular design. *Mechanical Manufacturing & Automation*, (1), p. 14-17.
- [9] Hou, L., et al. (2001) Template module based modularizing design of frame structure of hydraulic press. *Metallforming Machinery*, (4), p. 30-33.
- [10] Gao, G.D., Xu, Y.S. (2002) Algorithm of module selection in modularized design of products. *Journal of Mechanical Design*, (8), p. 5-7.
- [11] Wang, X.J., Chen, Z.C. (2001) Modularization design of XH754 Series machining center. *Machine Tool & Hydraulics*, (3), 46.
- [12] Deng, Y.Y., Wang, H.P. (2001) Main Transmission system CAMD in numerical control center based on the design theory of modularization. *Journal of Chongqing Institute of Technology*, vol. 15, no. 2, p. 85-89.
- [13] Wang, A.M., Meng, M.C., Huang, J.Y. (2003) Research on modular product family design methodology under multipurpose constraint environment. *Mechanical Science and Technology*, vol. 22, no. 4, p. 521-524.
- [14] Hu, W.G. (1994) Research and practice of the modular design of machine tools and the intelligent support system [Doctoral dissertation]. Huazhong University of Technology.
- [15] Pahl, G., Beitz, W. (1984) Engineering Design. *Spring-Verlag, The Design Council*, London.
- [16] Shi, J.F., You, L.H., Liang, X.C. (1997) Mechanical modularity. *Chongqing Press*, Chongqing.
- [17] Pan, S.X., Gao, F., Feng, P.E. (2003) Module partition method research under the circumstances about mass customization. *Chinese Journal of Mechanical Engineering*, vol. 39, no. 7, p. 1-6.
- [18] Gao, G.D. (2001) Research on virtual modular design and its application in numerical control machine [Doctoral dissertation]. Tianjin University.
- [19] Wang, G.Y., Wang, Y.Z. (2003) Application of information entropy fuzzy matter-element model based on AHP for projects assessment of foundation treatment. *Journal of Shandong University*, vol. 33, no. 4, p. 457-460.

- [20] Hou, L., Xu, Y.S. (2003) Research on product family modeling for generalized modular design. *China Mechanical Engineering*, vol. 14, no. 7, p. 596-599.
- [21] Stone, R.B. (1997) Towards a theory of modular design [Doctoral dissertation]. *The University of Texas at Austin*.
- [22] Sun, W., Liu, X.B., Han, Y.S., etc. (2001) Research on the methods of product design and product planning for mass customization. *Mechanical Science and Technology*, vol. 20, no. 3, p. 315-317.
- [23] Wang, J.J., et. al. (2002) Research of the system of customer requirement classification. *Journal of Dalian University*, vol. 23, no. 12, p. 48-54.
- [24] Wang, A.M., Meng, M.C., Huang, J.Y.(2002) Mathematical description and determining method of product platform for developing product families. *Journal of Tsinghua University*, vol. 42, no. 8, p. 1049-1052.
- [25] Gu, Y.K., Huang, H.Z. (2004) Fuzzy mapping between physical domain and function domain in design process. *International Journal of Uncertainty, Fuzziness and Knowledge-Based Systems*, 12(1).
- [26] Su, Q., Wang, K.L., Sun, J.C. (2001) Modularization of product in agile manufacturing. *Modular Machine Tool & Automatic Manufacturing Technique*, (4), p. 1-4.
- [27] Du, T.J., Huang, H. (2003) Research on the class and level of module decomposition in modular design. *Development & Innovation of Machinery & Electrical Products*, 2, p. 50-53.
- [28] Salhieh, S.M., Kamram, A.K. (1999) Macro level product development using design for modularity. *Robotics and Computer Integrated Manufacturing*, (15), p. 319-329.
- [29] Jiang, H., Xu, Y.S., Xie, Y. (1999) Research on modular dividing method of machinery products. *Manufacturing Technology & Machine Tool*, (3), p. 7-9.
- [30] Huang, H.Z. (1999) Fuzzy design. *China Machine Press*, Beijing.
- [31] Ren, S.L. (2002) Research on the modular design of artillery and the database [Master's dissertation]. Nanjing University of Science and Technology.
- [32] Guo, Y. (2000) Research on mass customization and key supporting techniques [Master's dissertation]. Dalian University of Technology.
- [33] Chen, Y.L., Xu, Y.S., Jiang, H., etc. (2000) Computer aided coding tools for modules of machining centers based on MDT. *Mechanical Science and Technology*, vol. 19, no. 3, p. 491-493.
- [34] Ying, J., Jiang, L., Pan, S.X. (1999) A solving model of cased based reasoning design problem. *China Mechanical Engineering*, vol. 10, no. 5, p. 555-558.
- [35] Zhang, Z.W., et al. (1998) Design manual of crane. *China Railway Publishing House*. Beijing.
- [36] Han, L. (2003) A new design system of overhead traveling crane based on AutoCAD [Master's dissertation]. Dalian University of Technology.
- [37] Kušar, J., Duhovnik, J., Tomažević, R., Starbek, M. (2007) Finding and evaluating customers' needs in the product-development proces. *Strojniški vestnik - Journal of Mechanical Engineering*, vol. 53, no. 2, p. 78-104.
- [38] Xu, Y.S., Hou, L., Zhang, L.H., etc. (2001) Theory of the generalized modular design of hydraulic press and its application. *Journal of Machine Design*, (7), p. 1-3.