

A PRELIMINARY S-N CURVE FOR THE TYPICAL STIFFENED-PLATE PANELS OF SHIPBUILDING STRUCTURES

PRELIMINARNA KRIVULJA S-N ZA TOGE PLOŠČATE PANELE ZA LADJEDELNIŠKE STRUKTURE

Luljeta Gusha¹, Skender Lufi², Marenglen Gjonaj²

¹Technological University "I. Q. Vlora", Marine Faculty, Naval Engineering Department, Lagja: Pavaresia, Rruga: Sadik Zataj, Vlora-Albania

²Politechnical University of Tirana, Mechanical Faculty, Mechanical Department, Sheshi: Nene Tereza, Tirana-Albania
gusha@aul.com.al

Prejem rokopisa – received: 2006-05-17; sprejem za objavo – accepted for publication: 2007-07-10

This paper presents the results of a preliminary study focused on the structural behavior of typical stiffened plate panels used for shipbuilding structures and their fatigue strength under a lateral load. The investigated panels are thin plates, welded with longitudinal bulb stiffeners through alternate welding seams. This makes the panel a composite structural element with a complex strength behavior. The aim of the research was to obtain data about the failure conditions of the panels. Testing covers the bending tests carried out on the real-size panels of shipbuilding structures. A reliable definition of a fatigue design curve was not possible due to the limited number of specimens, although a tentative S-N curve was drawn on the basis of the test data.

Key words: shipbuilding panels, fatigue, real-size testing, S-N data

Članek predstavlja rezultate preliminarne študije ciljane na strukturno vedenje tipičnih togih ladijskih panelov in utrujenostno trdnost pri bočni obremenitvi. Paneli so tanke plošče zvarjene z podolžnimi rebri za preprečenje izbočenja z alternativnimi spoji. Taki paneli so kompozitni strukturni elementi s kompleksnim trdnostnim vedenjem. Cilj raziskave je bil opredeliti podatke o pogojih za nastanek preloma panelov. Preizkusi so obsegali upogib panelov realne velikosti za ladijske strukture. Zanesljiva opredelitev krivulje S-N ni bila mogoča zaradi omejenega števila preizkusnih panelov. Zato je bila določena le poizkusna krivulja S-N na podlagi rezultatov preizkusov.

Ključne besede: ladjedelniški paneli, utrujenost, preizkušanje v realni velikosti, podatki S-N

1 INTRODUCTION

Stiffened plate panels are the basic structural components of a ship's structure. Fatigue constitutes a major source of local damage in ships and other marine structures, since the most important loading on the structure, the wave-induced loading, consists of large numbers of load cycles of alternating sign. The prevention of fatigue failure in ship structures is strongly dependent on proper attention to the design and fabrication of structural details. Much of the quantitative information on fatigue obtained by experiments and S-N fatigue design curves is drawn on the basis of test data.

With the test results, and based on Wöhler's diagram, a tentative attempt is made to construct an S-N curve for the stiffened panels, where the thin plates are welded with longitudinal bulb stiffeners through alternate welding seams.

According to IIW documents, more than 15 specimens are in general necessary to establish the fatigue limit and more than 25 for the S-N curve, using static analysis methods (e.g., the staircase method) ⁸.

2 EXPERIMENTAL

The experimental measurements were made at the DINAV of the Naval Structural Laboratory of Università degli Studi di Genova.

2.1 Data on the panel and model description

As a model for the experimental test, a stiffened plate panel of real size, simply supported, was considered. The effects of stress and initial distortion were not considered.

Panel-type stiffeners were welded in the span between the transversal T-beams, using alternate welding seams with a length of 50 mm and a step of 200 mm. It is worth pointing out that at a 50-mm interval the stiffeners are welded to the plate, alternatively on one or the other. The panels were built according to standard fabrication practice using semi-automatic arc welding. The welding parameters are as follows:

Wire: FRO Fluxofil 19, $d = 1$ mm

Voltage: 23/24 V, Current: 140/150 A

Welding speed: 50 cm/min

Throat: 3.5 mm

Table 1: Geometrical characteristics of the panel

Tabela 1: Geometrijske značilnosti panelov

Plate dimensions	$(1800 \times 2600 \times 5)$ mm
Stiffeners(HP80X6)	$I_x = 39.0 \text{ cm}^4$ $W_{\min} = 8.15 \text{ cm}^3$
Effective plate width included ($s = 500$ mm)	$I_x = 155 \text{ cm}^4$ $W_{\min} = 21 \text{ cm}^3$
Transversal beams	$(180 \times 90 \times 5 \times 8)$ mm $(180 \times 5; 90 \times 8)$ mm

Reference standard: MM-042F-331
 Welding on unpainted surfaces

Table 2: Characteristics of materials
Tabela 2: Lastnosti materiala

Yield stress	$\sigma_y = 355 \text{ N/mm}^2$
Yield load ($s = 500 \text{ mm}$)	$P_y = 49.7 \text{ MPa}$
Young's modulus	$E_s = 2 \cdot 10^5 \text{ MPa}$
Shear modulus	$G_{xy} = 0.793 \cdot 10^5 \text{ MPa}$
Poisson's modulus	$\nu = 0.33$
Density of the material	$d = 7.9 \cdot 10^{-5} \text{ kg/mm}^3$

All the panels were manufactured from the same material. The panel is modeled as shown in **Figure 1**, and is considered to be supported on two T-beams along both its longest sides (2600 mm) and along two other free sides (**Figure 2**).

The assumed failure criteria are:

- A crack propagation over the section of the bulb,
- A number of cycles $N = 1.0 \times 10^6$

2.2 Procedure and experimental tests

The bending was achieved with a transversal beam along the whole panel width. The loading beam had an

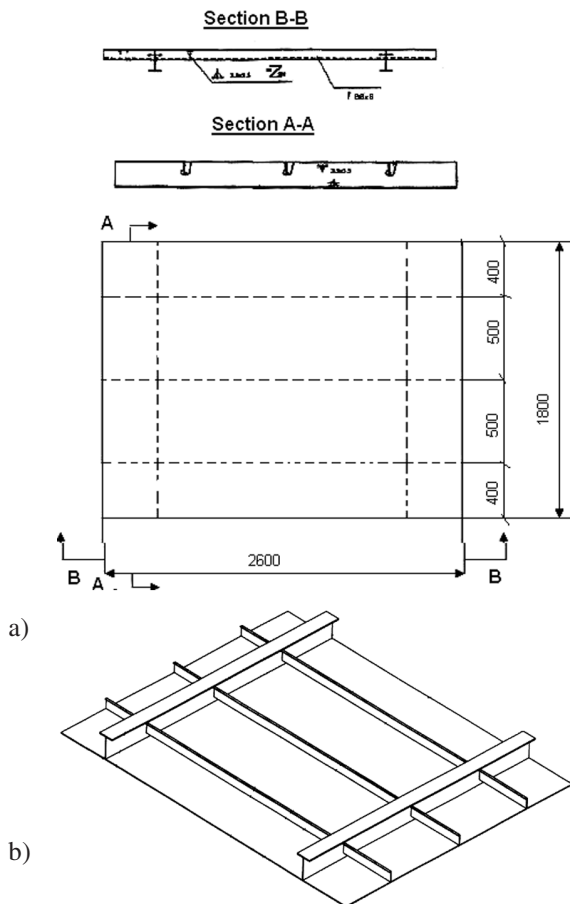

Figure 1: Sketch (a) and isometric view (b) of the tested panel
Slika 1: Skica (a) in izometričen (b) pogled preizkusnega panela

"I" section with two large flanks of size (1800 × 200) mm and a thickness of 20 mm^{1,12}. Its inertia moment is large enough to ensure a constant distribution of the load along the beam. Between the flat and the panel surface, a thick rubber strip was interposed during the tests in order to prevent damage to the surface. The strip had a width of 200 mm and this should be regarded as the area of the 200 MPa load application. The load jack is hinged to a frame and acts vertically downward, as shown in **Figures 2 and 3**. It was selected on the basis of the predicted limit load of 10 t. A load cell was interposed between the jack and the loading beam^{3,12}. Seven linear strain gauges for each panel and one load cell (200 MPa max. load), as in **Figure 3**, were applied for each test. Two rows of linear strain gauges were placed near the loading "I" beam (**Figure 3**). These strain gauges measure the strain in the longitudinal direction of the bulb after each loading sequence. The panels were tested in the range of about 0.7 yield stress with a sinusoidal pulsating load. The maximum stress during the fatigue test did not exceed the yield stress^{7,8,9,10}. The load and strain were continuously monitored. The tests were monitored with strain-gauge measurements and visual inspections. The signals were stored in the data files in millivolts and converted into the real physical quantities by means of a calibration (**Figure 4**). The displacement transducers were placed in their position and then calibrated "in situ" with mechanical gauges.

The acquisition program was run for every test at a sampling rate of 1.4–1.5 Hz^{1,8} for a predetermined period of time. For each acquisition the maximum, minimum, mean and range values were evaluated and subsequently converted into stress and the acting force.

The range versus cycles and the maximum range versus cycle plots are presented in **Figure 5 and 6**.

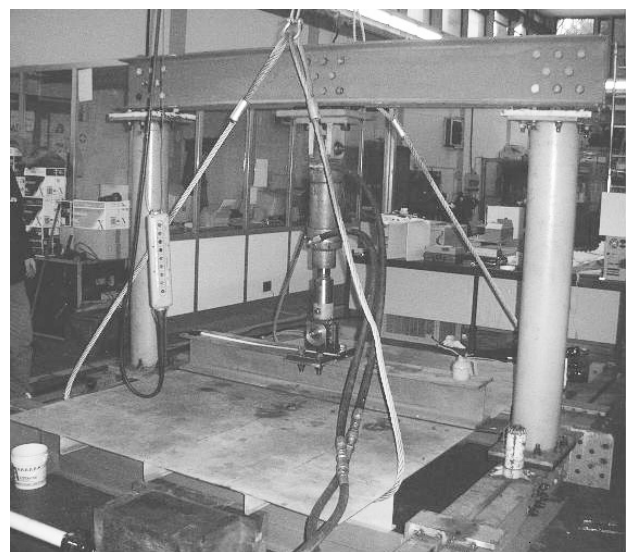

Figure 2: View of the testing device
Slika 2: Preizkusna naprava

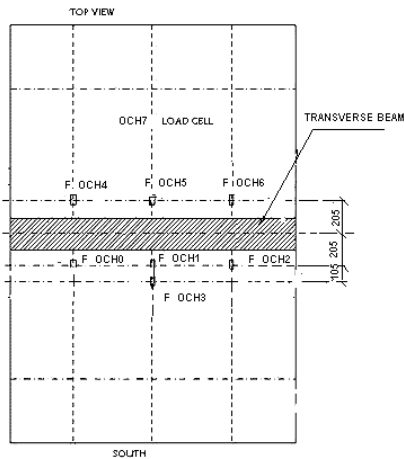

Figure 3: View of the position of the strain gauges
Slika 3: Položaji merilnih doz

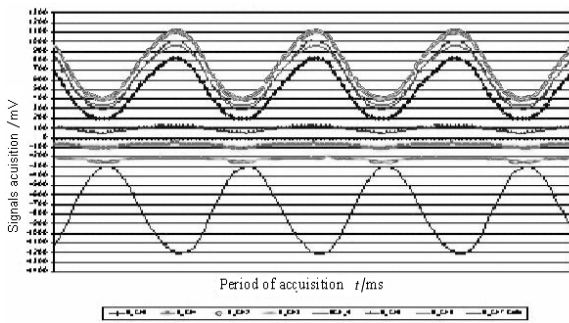

Figure 4: Gauges and load-cell measurements at the end of the test after about 1.45×10^6 cycles
Slika 4: Doze in meritve obremenitvenih celic pri koncu preizkusa pri $1,45 \cdot 10^6$ amplitudah

2.3 Results and discussion

The results are shown in graphical form in Figures 5, 6 and 7. The panel was loaded with a pulsating sinusoidal loading wave with a range of about 41 MPa, at a mean level of about 25 MPa for 10^6 cycles (stress ratio $R \approx 0.1$). No cracks were found.

The range load was then increased up to 52 MPa, at a mean level of 33 MPa (stress range $R \approx 0.1$) for 1.35×10^6 cycles. Then another 10^6 cycles were applied at 46.5 MPa, at the same mean level. No cracks were detected

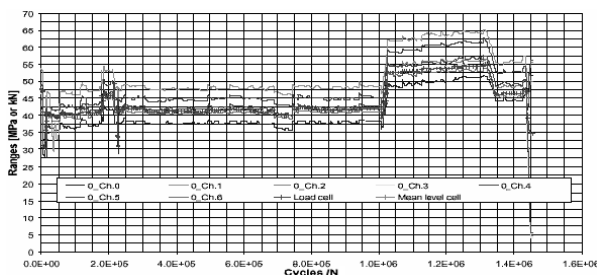

Figure 5: Test measurements plot: range vs. cycles.
Slika 5: Rezultati meritev obremenitev v odvisnosti od števila amplitud

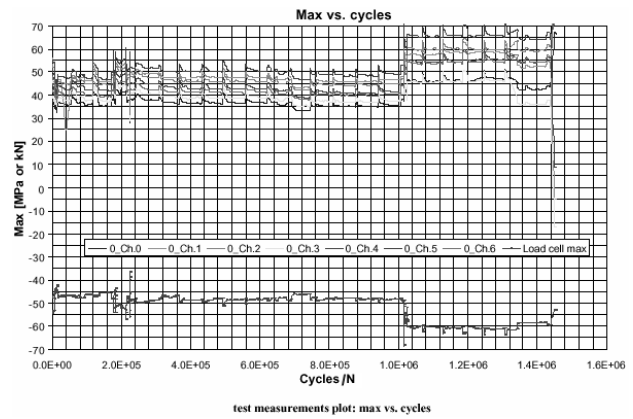

Figure 6: Test measurements plot: max vs. cycles
Slika 6: Rezultati meritev obremenitev v odvisnosti od števila amplitud



Figure 7: Cracks in the central stiffener, both sides and the lateral stiffener (after panel dismantling)
Slika 7: Razpok v centralnem rebri, obe strani in bočna utrditev (po demontaži panela)

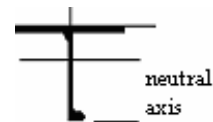

Figure 8: Composite cross-section of beam
Slika 8: Prečni prerez rebra

with a visual examination and strain-gauges signal analysis.

At about 1.45×10^6 cycles a crack started from the head of the central bulb stiffener about the span middle and propagated up to the plating, while a second crack started in the west side bulb stiffener in the same position and propagated up to the stiffener web. From the analysis of the gauge measurements, it is concluded that the crack propagated for about 10^4 cycles.

The boundary conditions of the panel are considered as simply supported, the load is applied in the center of the panel and the panel is in a positive bending moment condition with the maximum of the bending moment in the center of the panel.

According to the elastic beam theory, in this case, the neutral axis is near the plate, as in **Figure 8**, so the maximum stress is achieved at the head of the bulb.

In the preliminary assessment using the finite-element method, for these panels¹¹ and in static loading, three critical areas of the panels' collapse were identified:

- a) The region including the plate area between the stiffeners (in compression);
- b) The region including the plate area around the stiffeners (in compression);
- c) The region including the head area of the stiffeners (in tension)

The specific stress-strain situation in each of these regions defines the type of collapse that can occur in them. The expected collapse in the region (a) is generally of a static nature, while in the regions (b) and (c) it is generally of a fatigue type. In this case, since the region (b) is in compression, the region (c) is expected to collapse in fatigue^{2,4,10,11}. The finite-element analysis showed the region (c) as the hottest stress area between the (b) and (c) regions.

3 PRELIMINARY S-N CURVE

Due to the limited number of specimens it was not possible to obtain a curve. For this reason, a preliminary S-N curve was drawn on the basis of the test data. According to the IIW documents, more than 15 specimens are necessary to establish a reliable fatigue limit and more than 25 for the S-N curve, using static analysis methods (e.g., the staircase method)⁸. To construct the S-N curve, we relied on Wohler's curve. The shape of this curve is shown in **Figure 9**^{1,2,3,4,5,6,10}.

Where:

- S is the upper point, static resistance σ_r vs. 10^3 cycles.
- G is the point of the fatigue limit $\sigma_{a\infty}$ vs. 2×10^6 cycles (or an endurance limit).
- In the $\lg \sigma_a - \lg N$ diagram the curve slope is a constant k .

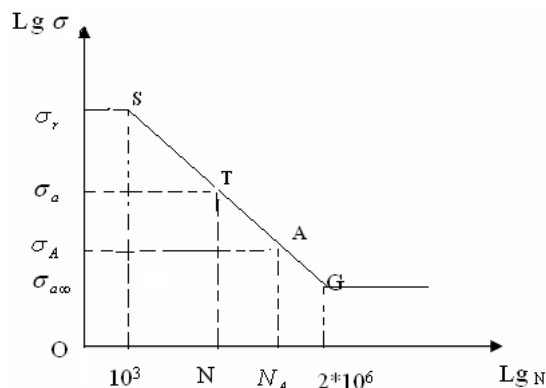

Figure 9: Typical S-N curve for a mild steel
Slika 9: Tipična krivulja S-N za konstrukcijsko jeklo

- The point A is the point of the conventional reference, N_A, σ_A

$$N\sigma_a^k = N_A\sigma_A^k \tag{1}$$

$$k = \frac{\lg_{10} \frac{N_A}{N}}{\lg_{10} \frac{\sigma_a}{\sigma_A}} \tag{2}$$

A typical value of $k = 3$ is given in several references^{1,2,3,13}.

In our case, since the load is a sinusoidal pulsing load: $r \approx 0.1$, $\Delta\sigma_E \cong \sigma_y = 355 \text{ N/mm}^2$ (see HSS $\Delta\sigma_E = 330 - 360 \text{ N/mm}^2$), where $\Delta\sigma_E = \sigma_{a\infty}$, and σ_y is the stress at the S point. The coordinates of the point G are $1.5 \cdot 10^5$ and 330, and the panel is loaded with 42 MPa at 10^6 cycles and with 52 MPa at $0.45 \cdot 10^6$ cycles.

From the De Saint Venant relation, $\sigma = \frac{M_b y}{I_{xx}}$, it is

deducted:

At 10^6 cycles, $P = 42 \text{ MPa}$, $\sigma_A = 278.8 \text{ N/mm}^2$ and at $0.45 \cdot 10^6$ cycles, $P = 52 \text{ MPa}$, $\sigma_T = 278.8 \text{ N/mm}^2$.

The proof of the service fatigue strength on the basis of the damage is the accumulation rule according to Miner:

$$D = \sum_{j=1}^n \frac{N_j}{N_{fj}} \tag{3}$$

$$D \leq D_{\text{per}} \text{ where } D_{\text{per}} = 0.5 - 1.0 \tag{4}$$

where D is the total damage, D_{per} is the permissible total damage, ΔN_j is the number of cycles on level j , N_{fj} is the number of cycles of failure on the level j according to the allowed stress S-N curve, j is the number of the stress level and n is the total number of stress levels.

- Let us now deduce the value of k :

$$1 = \frac{N_1}{N_{f1}} + \frac{N_2}{N_{f2}} \tag{5}$$

$$N_{f1}\sigma_1^k = N_{f2}\sigma_2^k \tag{6}$$

Starting from the conventional point S($10^3, \sigma_y$) with $\sigma_y = 355 \text{ N/mm}^2$ it is possible to write:

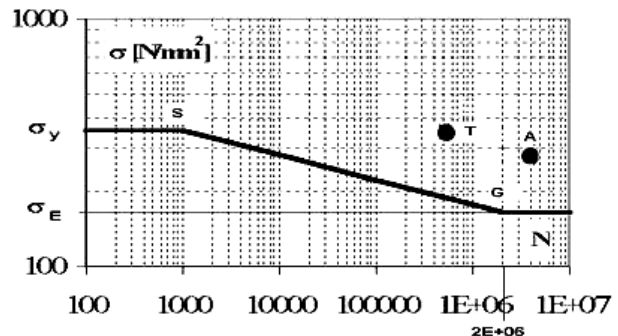

Figure 10: Wöhler curve for the panels
Slika 10: Wöhlerjeva krivulja za panele

$$10^3 \left(\frac{\sigma_y}{\sigma_2} \right)^k = N_1 \left(\frac{\sigma_1}{\sigma_2} \right)^k + N_2 \quad (7)$$

where, $\sigma_1 = \sigma_A = 278.8 \text{ N/mm}^2$, $\sigma_2 = \sigma_T = 345.2 \text{ N/mm}^2$

From the three mentioned equations a tentative value of $k = 10$ is deduced. This is in agreement with NAFEMS³, because the crack propagated in the bulb head, without weld seams and the material behaves as if it is unwelded².

From equations 5,6 N_{f1} , N_{f2} we deduced:

$$\begin{cases} N_{f1} = 4810000 \\ N_{f2} = 568091 \end{cases}$$

In this step it is necessary to verify that $\sigma_{a\infty} = \sigma_E$, assuming a known number of cycles corresponding to the endurance limit $\sigma_{a\infty} = \sigma_E$ at $2 \cdot 10^6$.

From the relation $N\sigma_a^k = N\sigma_A^k$ we can write:

$$N_{f1} \sigma_1^k = N_{fE} \sigma_E^k \Rightarrow \sigma_E = 166.006 \text{ N/mm}^2$$

Finally, it is possible to construct the preliminary S-N curve for the panel shown in **Figure 10**.

The S-N curve with these characteristic points, based on the damage-accumulation rule according to Miner and the curve of Wohler, has the following coordinates.

$$A(N_{f1}, \sigma_1) = A(4810000, 278.8)$$

$$T(N_{f2}, \sigma_2) = T(568091, 345.2)$$

$$G(N_E, \sigma_E) = G(2 \cdot 10^6, 166.006)$$

$$S(10^3, \sigma_Y) = S(10^3, 166.006)$$

4 CONCLUSIONS

From the experimental point of view, it is evident that the points A and T are situated in the safety zone.

The value of the curve's slope is $k = 10$, and it can be increased up to $k = 14$ (the results can be in a scatter band with the value of "k" from 10 up to 14).

Future results will permit a further revision and implementation with the aim to obtain good agreement between the Wöhler curve and the experimental data.

5 REFERENCES

- ¹ G. Sines, J. L. Waisman, Metal fatigue, London, (1959)
- ² S. J. Maddox, Fatigue strength of welded structure, England, 1991
- ³ B. P. Atzori, Introduzione alla progettazione a fatica, *NNAMFES*, Italy, 2001
- ⁴ O. Hughes, Ship structural design, Sydney, 1983
- ⁵ O. Hughes, J. B. Caldwell, Marine structures selected topics, examples and problems, Sydney, 1991
- ⁶ J. J. Jensen, Load and global response of ships, Denmark, 2000
- ⁷ I. S. O. Standard proposal. Fatigue testing of welded components, France, 1996
- ⁸ H. P. Lieurade, I. Huther, IIW Fatigue Testing Standard and Effect of Quality and Weld Improvement Methods WRC Proceeding IIW, 1996
- ⁹ International Institute of Welding, IIW Recommendation on large scale fatigue testing of welded components, Germany, 1999
- ¹⁰ D. Radaj, C. M. Sonsino, Fatigue assessment of welded joints by local approaches, England, 1998
- ¹¹ L. Gussha, S. Lufi, Strain-stress analysis of stiffened plate panels of shipbuilding structures, *ACTA Universitatis Pontica Euxinus, Rumania* 5 (2005), 2
- ¹² L. Gussha, Typical stiffened plate panels in shipbuilding – ultimate and fatigue strength. Università degli Studi di Genova DINAV, Genova (Internal Report 03CRI04), 2003
- ¹³ M. Gjonaj, F. Pejani, Detale Makinash. Kritere Kryesore te Llogaritjes se Detaleve te Makinave, Tirana, Albania, 1987