

Integrated Hall Magnetic Angle Sensors

Radivoje S. Popović

EPFL - Swiss Federal Institute of Technology; Lausanne, and SENIS AG, Zug, Switzerland

Abstract: A magnetic angle sensor is a matched combination of a permanent magnet, affixed to a rotating shaft, and a magnetic field sensor. The magnet part of the angle sensors is configured so as to create either a magnetic field with an angle-dependent component perpendicular to the chip surface; or two angle-dependent components parallel with the chip surface. The magnetic field component perpendicular to the sensor dice is measured by planar Hall devices. The two in-plane magnetic field components are measured either by a combination of planar Hall devices and an integrated magnetic flux concentrator (IMC-Hall), or by vertical Hall devices. The IMC-Hall is the most used technology for implementing a compass in mobile telephones. The circular vertical Hall device is most suitable for high-speed rotation angle sensing. The major performance-limiting factors of magnetic angle sensors are non-uniformity of magnets, imperfections in the integrated magnetic sensor IC, and thermal drift. The magnetic sensing part of contemporary magnetic angle sensors is a CMOS IC, incorporating Hall devices, biasing circuit, amplifiers and other analog signal conditioning circuits, analog-to-digital convertors, and digital circuits for angle retrieval and correction of errors.

Keywords: magnetic angle sensor, Hall device, compass

Integriran Hallov magnetni senzor kota

Izveček: Magnetni senzor kota je kombinacija trajnega magneta, nameščenega na rotirajoč držaj, in senzorja magnetnega polja. Magnetni dela senzorja kota je konfiguriran tako, da ali ustvarja magnetno polje s kotno komponento pravokotno na površino čipa ali dve kotno odvisni komponenti vzporedni s površino čipa. Magnetno polje v normalni s površino čipa se meri s planarno Hallovo napravo. Dve planarni komponenti magnetnega polja se merita lahko s kombinacijo planarnega Hallovega senzorja in integriranega koncentradorja magnetnega pretoka (IMC-Hall) ali pa z dvema vertikalnima Hallovima senzorjema. IMC-Hall je najbolj uporabljena tehnologija za izdelavo kompasa v mobilnih telefonih. Rotirajoča vertikalna Hallova naprava je bolj primerna za zaznavanje rotirajočih kotov z veliko hitrostjo. Največje omejitve lastnosti magnetnih kotnih senzorjev je nehomogenost magneta, nehomogenost integriranega magnetnega senzorja in temperaturne spremembe. Magnetni senzorski del kotnega senzorja je CMOS integrirano vezje, ki vključuje Hallove senzorje, usmerniško vezje, ojačevalce in ostala analogna vezja, analogno digitalne pretvornike in digitalno vezje za kompenzacijo in popraviljanje napak.

Ključne besede: magnetni senzor kota, Hallov senzor, kompas

* Corresponding Author's e-mail: radivoje.popovic@epfl.ch

1 Introduction

An angle sensor converts the angular position of a rotating mechanical part into a corresponding electronic signal. The oldest known angle sensors were based on the sliding-contact resistor potentiometer. Modern angle sensors are contactless and consequently much more reliable. Contactless angle sensors may be based on various operating principles, including optical, capacitive, inductive, and magnetic. Optical angle sensors, better known as optical (angle) encoders, have the best performance, but they are also the most expensive. In a large application area requiring accuracy up to 0.1°, magnetic angle sensors have by far the best performance – price ratio. By analogy with optical encoders, magnetic angle sensors are also called magnetic angle encoders, particularly if they have a digital output signal.

A magnetic angle sensor consists of a combination of a permanent magnet and an adequate magnetic sensor, as shown in Figure 1. The magnet is typically mounted on a rotating shaft so that the magnetic field sensed by the magnetic sensor also rotates. The angular position of the magnet, and so also of the shaft, can be then retrieved from the output signals of the magnetic sensor. The structure shown in Figure 1 is called end-of-shaft configuration. If the end of a shaft is not available, then the shaft may be inserted into a hole in the magnet, and the magnetic sensor is positioned off-axis, near the magnet. This configuration is known as trough-shaft or side-shaft magnetic angle sensor.

The notion of angle is closely related with the notion of direction. Since direction is the basic property of a

vector, a magnetic vector sensor can be readily used as an angle sensor. But in most cases, the form of the magnetic field in the magnetic angle sensor is such that the associated magnetic sensor needs to measure only two, and in some cases even only one component of the magnetic field.

A compass can be also considered as a kind of magnetic angle sensor, in which the role of the magnet plays Earth. But a good electronic compass has to measure all three components of the Earth's magnetic field, that is, it should be a magnetic vector sensor.

Magnetic angle sensors provide contactless measurement, can work in harsh environments, and are inexpensive. Good magnetic angle sensors have measurement range from 0° to 360° , without a dead angle, and absolute accuracy up to 0.1° .

Magnetic angle sensors are typically applied as contactless potentiometers, valve position sensors, single- and two-axis joysticks, motor shaft angle sensors, compasses, etc. They are widely used in industrial, automotive, and consumer products.

The maximum rotation velocity in most magnetic sensor applications do not exceed a few thousands rotations per minute (rpm). But in order to insure a low delay between an instantaneous angular position and the related output signal of the angle sensor, it is often necessary that the angle sensor's bandwidth is several tens of kHz. Moreover, there are applications where a much higher sensor's bandwidth is required, for example: high performance hard disc drives rotate at 15 000 rpm, the fastest gas turbine engines reach 165 000 rpm, electromechanical batteries can reach 200 000 rpm, to mention but a few.

The magnetic sensors applied in magnetic angle sensors may be Hall devices [1] or ferromagnetic magneto-resistors, i.e., AMRs [2] and GMRs [3, 4]. Hall devices have a great advantage of being fully compatible with IC technologies, which allows for making a Hall magnetic sensor as an application-specific integrated circuit (ASIC). Accordingly, a modern magnetic sensor typically incorporates a single Hall magnetic sensor IC chip, containing Hall elements, biasing and signal conditional electronics, and means for angle retrieval.

In this paper I will review the most successful contemporary concepts of magnetic angle sensors based on integrated Hall magnetic sensors. This is an updated version of an earlier review [5]. In the present paper I will also briefly discuss the magnets for magnetic angle sensors.

2 Angle sensors based on classical hall devices

A classical Hall device is a plate-like structure with 4 contacts, also called a Hall plate [1]. When implemented by using integrated circuit technology, a Hall plate is positioned "horizontally" (in parallel) with respect to the surface of the IC dice. For this reason, a classical Hall device is sometimes referred to as a horizontal Hall device. A Hall plate responds to a magnetic field that is perpendicular to its plane. Therefore, the magnets of the first Hall magnetic angle sensors were designed so as to provide a convenient angular dependence of the component of the magnet's field perpendicular to the Hall sensor chip. One concept of such magnetic angle sensors, which is still much used, is illustrated in Figure 1.

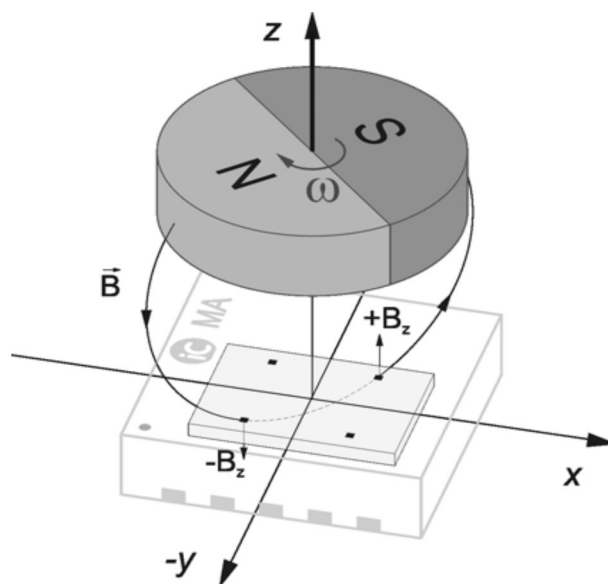

Figure 1: A magnetic angle sensor based on an integrated array of Hall plates.

Figure 1 illustrates a magnetic angle sensor based on an integrated array of Hall plates [6, 7]. In this concept, several "horizontal" Hall plates measure the local vertical components of the magnetic field carried by a radially polarized magnet, which is fixed on the end of a shaft. In the Hall sensor chip, the difference of the magnetic fields "seen" by the diametrically positioned Hall plates (for example, $+B_z - (-B_z)$ in Figure 1) is built. As the magnet turns, this difference varies as the sinus or cosine of the rotation angle. The rotation angle can be retrieved from the output signals of at least two pairs of the Hall devices in several ways – see Section 6.

A sensor like that in Figure 1 can measure angles at end-of-shaft over the whole range 0° to 360° . Thanks to the differential measurement, several parasitic effects cancel, including the matched parts of the offsets

of the diametrically positioned Hall plates and the external magnetic fields. An unpleasant feature of this concept is that, for good performance at a reasonable distance magnet – chip, it requires the Hall elements to be positioned on a circle of a relatively large diameter, typically $\geq 2\text{mm}$. Therefore, the IC-chip of such an angle sensor can be neither very small nor very inexpensive. Moreover, this concept is not convenient for through-shaft angle sensors.

3 Angle sensors based on hall sensors with magnetoconcentrator

If combined with a “soft” ferromagnetic plate, in the way illustrated in Figure 2, a group of horizontal Hall device can be converted into a magnetic sensor that responds to all three components of magnetic field [8]. The ferromagnetic plate functions as a magnetic flux concentrator. An integrated combination Hall plates – magnetic flux concentrator (in short: integrated magneto-concentrator or IMC) can be used to build a two-axis or three-axis Hall magnetic field sensor.

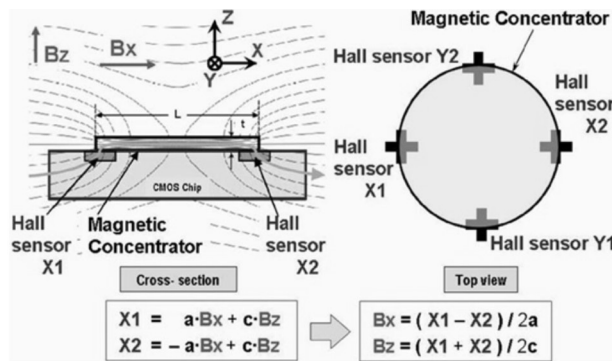

Figure 2: The principle of the IMC-Hall two-axis or three-axis magnetic field sensor (figure from [9]).

In Figure 2, the IMC has the form of a thin disk. The Hall elements are positioned under the periphery of the disk. For each horizontal sensing axis (X and Y) there are two Hall elements placed at the two opposite ends of the disk diameter parallel with the corresponding axis. The concentration of the magnetic flux lines by IMC produces (locally, near the Hall plates) the perpendicular components of a magnetic field B . The difference of the output signals of the Hall plates X1 and X2 is proportional to the parallel field component B_x . The B_y component is measured in the analogous way. The B_z component is the sum of all Hall signals.

A two-axis (X and Y) version of an IMC-Hall magnetic sensor, combined with a permanent magnet like that in Figure 1, gives a magnetic angle sensor. As the in-chip-plane component of the magnetic field of the magnet

rotates for an angle α , the difference of the Hall voltages of the two non-neighboring Hall elements vary as $\cos\alpha$ and $\sin\alpha$. The angular position of the magnet can be found from these two signals - see Section 6. This device provides, without any calibration, accuracy better than 0.5° over the measurement range of 360° [8].

The main advantages of an angle sensor based on the IMC-Hall combination are robustness and scalability. For the in-chip-plane component of the magnetic field, the IMC provides a magnetic gain, which is illustrated by the high density of the magnetic flux lines penetrating the Hall plates in Figure 2. This leads to a good signal to noise ratio of the sensor, even when the magnet is small or is placed at a relatively large distance from the IMC-Hall chip. For these reasons, an IMC-Hall angle sensor is very immune to the variations of the shape, strength, and the position of the applied permanent magnet. The magnetic field sensing area of an IMC-Hall sensor typically occupies very small portion of the sensor IC chip area, and does not hamper miniaturization of the chip. The IMC-Hall technology enabled development and successful commercialization of a number of IC for magnetic angle sensors and some other products [10]. An IMC-Hall IC for magnetic angle sensors is suitable also for the implementation of through-shaft angle sensors [11]

But the IMC-Hall technology brings about also some secondary effects that limit the range of the magnetic fields in which an IMC-Hall angle sensor functions well. At high magnetic fields the magnetic saturation of the magnetic flux concentrator produces nonlinearity error [12]. In some commercially-available IMC-Hall angle sensor ICs, the saturation starts when the external flux density reaches 60mT. At low magnetic fields, two other effects may deteriorate angle measurement accuracy. One is perming – a remnant magnetization of the IMC, which may produce in the Hall elements an unpredictable offset field of some micro-tesla. The other is the influence of external magnetic field, which is also amplified by IMC, and cannot be distinguished from the local field carried by the rotating magnet.

The deposition and structuring of the IMC requires post-processing of the Hall IC wafers. Therefore, at the same other circumstances, an IMC-Hall sensor has to be more expensive than a “bare” Hall sensor.

4 Angle sensors based on vertical hall devices

In a vertical Hall device [13] the region that plays the role of the Hall plate is made to be perpendicular to the

chip plane (therefore the attribute “vertical”). A merged combination of two mutually orthogonal vertical Hall devices gives a good magnetic sensor for the simultaneous sensing of the two in-plane components of a magnetic field. Based on this device a magnetic angle sensor was demonstrated [14]. But this first two-axis vertical Hall device was fabricated in a specific process, which is not compatible with modern IC technologies. Later, we developed also integrated vertical Hall devices: we applied a high-voltage CMOS technology, and used the deep n-well for the active region of the vertical Hall device. An integrated magnetic angle sensor based on such integrated vertical Hall devices [15] has similar performance as the one based on the IMC-Hall technology.

The most recently developed magnetic angle sensors are based on the circular vertical Hall device (CVHD) [16, 17]. The CVHD is illustrated in Figure 3. The active region of this device is a deep N-well ring, on whose surface are positioned several equally spaced N+ contacts. Any adjacent 5 contacts and the corresponding segment of the N-well make a vertical Hall device. The contacts can be connected to a current source and/or to an amplifier via an array of CMOS switches. By activating the appropriate switches, the active 5-contact-portion of the ring can be moved, step by step, around the ring. This is equivalent with moving a vertical Hall device around the ring. At each instant, the magnetic sensitivity vector of the device is collinear with the radius vector of the central contact of the currently active vertical Hall device. That means that the magnetic sensitivity vector of the CVHD rotates. The Hall voltage of a Hall device is given by the scalar product

$$V_h \approx \mathbf{S} * \mathbf{B} \tag{1}$$

where \mathbf{S} denotes the magnetic sensitivity vector of the Hall device and \mathbf{B} denotes the magnetic flux density vector. If the \mathbf{S} - vector rotates so fast that \mathbf{B} could be considered stationary, then the output voltage of a CVHD is given by

$$V_h \approx S B \cos(\omega t + \alpha) \tag{2}$$

where S denotes the magnitude of the magnetic sensitivity vector of the Hall device, B - the in-chip-plane component of the magnetic flux density vector, ω - the angular velocity of the magnetic sensitivity vector of the CVHD, t - the time, and α - the instantaneous in-plane angle (azimuth) of the B - vector with respect to a reference axis. Therefore, the phase shift of the CVHD output signal directly gives the angle α of the in-plane magnetic field. This means that a CVHD-based magnetic angle sensor does not need any additional angle-

retrieving calculation or other procedure, which makes it very suitable for high-speed rotation angle sensing.

Another version of such magnetic angle sensor is based on two miniaturized 8-contact CVHDs (8CVHD) whose sensitivity vectors rotate in opposite directions, Figure 4 [18, 19]. The output voltages of the two 8CVHDs are separately processed in two channels and act as a reference one to another. Therefore there is no need for the reference signal as in [17]. The output of the sensor is a pulse-width modulated signal whose width is proportional to twice the angle enclosed between the in-plane magnetic field vector and the reference axis. The use of two devices doubles the sensitivity of the sensor, though at the expense of reduced angular measurement range. Logic circuit, driven by an on-chip clock controls the switches. The dimensions of the chip are about 2 x 2 mm.

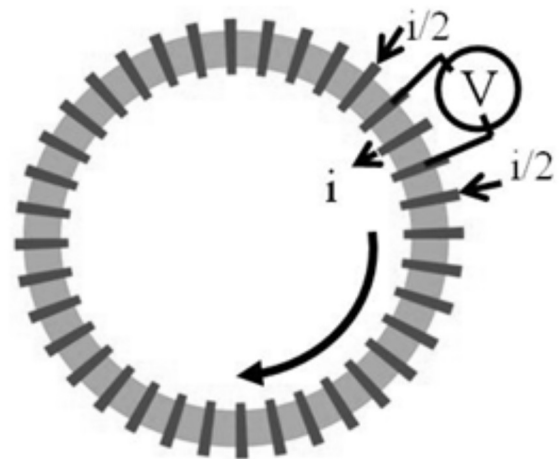

Figure 3: Principle of the circular vertical Hall device (CVHD). The ring represents a narrow n-well region, and the radial bars are the N+ contacts. An array of integrated CMOS switches (not shown) connects sequentially a set of 5 contacts, so that the 5-contact vertical Hall device virtually moves along the ring.

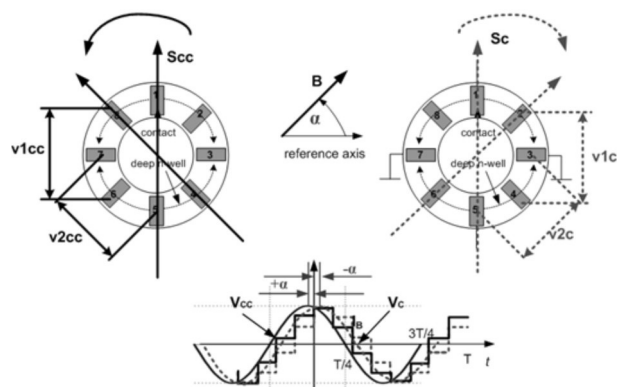

Figure 4: Biasing and sensing of the Hall voltages of the two 8CVHDs. Low-middle figure: clockwise (dashed line), counter clockwise (full line) and the band-pass fil-

tered signals for the DC magnetic field enclosing the angle α with the reference axis.

The angle sensors based on the vertical Hall technology are even more robust than those based on the IMC-Hall technology. A vertical Hall device responds to a strictly in-chip-plane component of a magnetic field with negligible non-linearity. In particular, in vertical Hall technology the problems of perming and magnetic saturation do not exist. On the other hand, integrated vertical Hall devices tend to have higher equivalent offset field and noise than the IMC-Hall devices. Therefore, in angle sensors based on the vertical Hall technology it is beneficial to apply stronger magnets.

5 Compass and other magnetic direction sensors

The magnitude of the magnetic field at the Earth's surface ranges from 25 to 65 micro-tesla. This had been long considered a too weak field to be measured by integrated Hall magnetic sensors. Moreover, an electronic compass should measure all three components of the Earth's magnetic field, whereas a classical Hall plate is a single-axis magnetic sensor. But the advent of the IMC-Hall technology has changed the circumstances: an IMC provides a magnetic gain for the two in-chip-plane components of the measured magnetic field; and the combination IMC-Hall allows for sensing all three components of a magnetic field on a single chip: see Figure 2. Thanks to these facts, the IMC-Hall is currently the dominant technology used in electronic compass ICs, particularly in mobile telephones [9], [20].

An integrated three-axis magnetic sensor, a magnetic vector sensor, can be also realized by combining at least two vertical Hall devices, one horizontal Hall device, and signal conditioning electronics on a same chip [21]. The latest improvement in the magnetic resolution of the integrated vertical Hall devices [22] opens the way for the realization of the integrated magnetic vector sensors with nearly as high resolution as that of an IMC-Hall 3-axis magnetic sensor, but without the shortcomings of the IMC (perming, saturation, cost).

A high resolution, high magnetic range, and low-cost magnetic vector sensor would be a key component of a 3D position and/or direction sensor [23].

6 The magnet and its position

The magnetic signal that is measured by any of the magnetic sensors described so far is provided by a

moving magnet, which is a part of an angle or direction sensor system. The optimal shape of the magnet's field depends on the type of the employed magnetic sensor. Tolerances in the distribution and the angular dependence of the magnet's field with respect to the "normal" (assumed) values may deteriorate the performance of the magnetic angle sensor.

By way of example, consider a magnetic angle sensor with a magnetic field sensor that responds to the in-plane component of the magnetic field, such as that based on IMC-Hall or vertical Hall technology. Then the rotation angle of the in-chip-plane component of the magnet's field vector should be the same as the rotation angle of the shaft. This is the case if the magnetic field is homogeneous. Since real magnets are subject to manufacturing tolerances, it is often necessary to measure the homogeneity of its magnetic field over an area of interest. Figure 5 [24] shows the result of such a measurement.

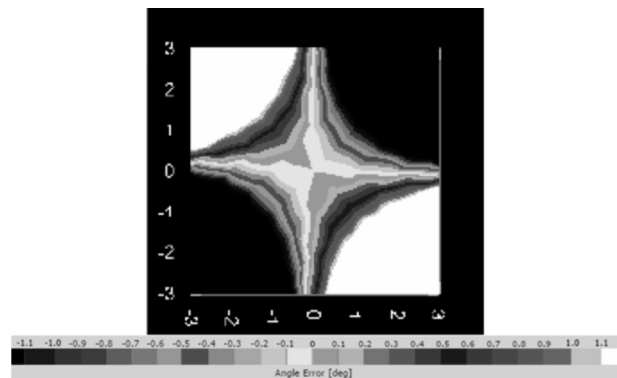

Figure 5: Measured distribution of the homogeneity error of a ferrite disc-shaped magnet, diameter 10mm. The measurement was performed by a precise 3D magnetic field mapper [25].

The quality of the magnet and the accuracy of the positioning of the magnet and the magnetic sensor IC may be the dominant factors that determine the accuracy of a magnetic angle sensor.

6 Signal conditioning

All integrated Hall magnetic sensors described above include biasing and signal conditional electronics. The signal conditioning includes amplification, reduction of offset, noise, and influence of temperature, analog to digital conversion, and retrieval of the angle of the magnetic field vector.

In contemporary integrated Hall magnetic sensors the crud offset is reduced by orthogonally coupling of 2 or more integrated Hall elements, and the residual offset

and $1/f$ noise are further reduced by the spinning current method [1].

The temperature dependence of the magnetic sensitivity per se is not a problem in most of the magnetic angle or direction sensors, since the retrieved angle depends on the ratio of two signals. However, the effective temperature coefficients of apparently equal devices may depend on their position on the chip. This comes about mostly because of the “co-operation” of the thermo-mechanical stress in the chip and the piezo-resistive, piezo-Hall, and piezo-junction effects. These effects are also the origin of offset and gain instability and miss-match of different signal processing channels. This problem can be alleviated by passing all sensor signals as much as possible through a same processing channel.

After A-D conversion of the Hall signals, the rotation angle can be retrieved in several ways, including the application of CORDIC algorithm (COordinate Rotation Digital Computer) [25], calculation of tangent and finding arc tangent from a look-up table, and by interpolation of the signals from an array of several Hall devices positioned around a circle.

In the CVHDs, the result of angle measurement appears as the phase shift between two ac signals, which can be measured by a phase detection circuit. Then the sensor output signal can be a pulse-width modulated signal, or a digital signal – the number of the clock periods within the pulse-width.

The accuracy of a magnetic angle sensor can be much improved by calibration. To this end, the sensor system should incorporate a temperature sensor, memory, and an adequate information processing. The calibration procedure might look like that used in an advanced 3-axis teslameter [27]. The efficiency of calibration is ultimately limited by noise and instability phenomena.

7 Conclusions

A magnetic angle sensor incorporates a magnet and a magnetic field sensor. The magnetic field sensor is usually an integrated sensor based on classical planar Hall devices, an integrated combination of Hall plates and magnetic flux concentrators (IMC-Hall), or vertical Hall devices.

The IMC-Hall technology provides magnetic gain and 3-axis magnetic sensing. The majority of compass chips in contemporary mobile telephones are based on the IMC-Hall. A magnetic angle sensor based on the IMC-

Hall can work with smaller or more distant magnets. However, an IMC-Hall saturates at about 60mT; and at low magnetic fields, it suffers from perming and external disturbances.

In the sensors based on the vertical Hall technology the problems of perming and magnetic saturation do not exist; but the vertical Hall sensors have higher offset and noise than IMC-Hall sensors, and therefore require stronger magnets.

The magnetic angle sensor based on the circular vertical Hall device provides the measured angle very quickly; therefore they are very suitable for high-speed rotation angle sensing.

The dominant sources of errors in a magnetic angle sensor are related to the inhomogeneity of the magnet and the temperature drifts. Most of the errors can be corrected by calibration, but the ultimate limit of accuracy comes from noise and instability phenomena.

References

1. R.S. Popovic, “Hall Effect Devices”, 2nd edition, Inst. of Physics Publishing, Bristol and Philadelphia 2004.
2. AMR angle sensor products - for example: www.sensitec.com/english/products/angle/winkel.html
3. C. Giebler, D.J. Adelerhof, A.E.T. Kuiper, J.B.A. van Zon, D.Oelgeschläger, G. Schulz, “Robust GMR sensors for angle detection and rotation speed sensing”, *Sens. Actuators A* 91 (2001) 16–20
4. GMR angle sensor products - for example: <http://www.infineon.com/cms/de/product/sensor-ics/magnetic-sensors/angle-sensors/channel.html?channel=db3a304332ae7b090132b007569a015d>
5. R. S. Popovic, S. Reymond, P. Kejik, M. Banjevic, “Integrated Magnetic Angle Sensors”, Invited Paper, 31st International Conference MIPRO, May 26-30, 2008, Opatija, Croatia.
6. M. Metz, A. Häberli, M. Schneider, R. Steiner, C. Maier, H. Baltes, “Contactless angle measurement using four Hall devices on single chip”, in: *Proceedings of the Transducers’97, Chicago, USA, 1997*, pp. 385–388.
7. Planar Hall angle sensor products - for example: <http://www.ams.com/eng/Products/Position-Sensors>; <http://www.rls.si/en/onaxis-magnetic-encoder-technology--15867>
8. R.S. Popovic, C. Schott, P.M. Drljaca, R. Racz, “A new CMOS Hall angular position sensor”, *Technisches Messen*, tm Vol 6, June 2001, 286-291.

9. <http://asia.iop.org/cws/article/news/42833>, <http://spectrum.ieee.org/semiconductors/devices/a-compass-in-every-smartphone>
10. IMC-Hall products - for example: <http://www.melexis.com/Hall-Effect-Sensor-ICs/Triaxis®-Hall-ICs/Triaxis-760.aspx>
11. <http://www.melexis.com/Assets/MMT-and-Melexis-Development-Note-Through-Shaft-360°-Magnetic--Rotary-Position-Sensor-5056.aspx>
12. P. M. Drljaca, M. Demierre, C. Schott, R. S. Popovic, "Nonlinear Effects In Magnetic Angular Position Sensor With Integrated Flux Concentrator", Proc. 23rd Int. Conference On Microelectronics (MIEL 2002), Vol. 1, Nis, Yugoslavia, 12-15 May, 2002, pp. 223-226.
13. R. S. Popovic, "The vertical Hall-effect device", IEEE Electron. Dev. Lett. EDL-5, 5(1984), 357-358.
14. F. Burger, P.A. Besse and R.S. Popovic, "New Fully Integrated 3-D Silicon Hall Sensor for Precise Angular Position Measurements", Sensors and Actuators, A 67(1998), 72-76.
15. M. Demierre, E. Schurig, C. Schott, P.A. Besse and R.S. Popovic, "Contactless 360deg absolute angular CMOS microsystem based on vertical Hall sensors", Sensors and Actuators A: Physical, 116, 1(2004), 39-44.
16. Popovic Radivoje, Kejik Pavel, Reymond Serge, "Magnetic field sensor for measuring a direction of a magnetic field in a plane", patent application Nr. EP20070109063 20070529
17. P. Kejik, S. Reymond, R. S. Popovic, "Circular Hall transducer for angular position sensing", Transducers '07 & Eurosensors XXI conference, June 10-14, 2007, Lyon, France, Digest of technical papers vol. 2, 2593-2596.
18. Popovic Radivoje, Mirjana Banjevic, "Magnetic field sensor for measuring a direction of a magnetic field in a plane and current sensor", US patent 8,624,587 B2
19. M. Banjevic, B. Furrer, M. Blagojevic, R.S. Popovic, "High-speed magnetic angle sensor based on miniaturized circular vertical Hall devices", Sensors and Actuators A 178 (2012) 64-75.
20. <http://spectrum.ieee.org/semiconductors/devices/a-compass-in-every-smartphone>
21. D. Popovic, S. Dimitrievic, M. Blagojevic, P. Kejik, E. Schurig, R. S. Popovic, "Three-Axis Teslameter With Integrated Hall Probe", IEEE Transactions on Instrumentation and Measurement, vol. 56, August 2007, 1396-140.
22. R.S. Popovic, "High Resolution Hall Magnetic Sensors", MIEL May 12-14, 2014, Belgrade, Serbia.
23. E. Paperno, I. Sasada, and E. Leonovich, "A New Method for Magnetic Position and Orientation Tracking", IEEE TRANSACTIONS ON MAGNETICS, 37 (2001) 1938- 1940.
24. M. Blagojevic, N. Markovic, and R. S. Popovic, "Testing the Homogeneity of Magnets for Rotary Position Sensors", May 4-8, 2014, Dresden, Germany
25. <http://www.senis.ch/magnetic/magnetic-field-scanner/overview-magnetic-field-scanner>
26. J. E. Volder, "The CORDIC trigonometric computing technique" IRE Trans. Elect. Comp. EC-8, 330 (1959)
27. Dragana Popovic Renella, Sasa Dimitrijevic, Sasa Spasic and Radivoje S. Popovic, "High-Accuracy Teslameter with Thin Three-Axis Hall Probe", 20th IMEKO TC4 International Symposium and 18th International Workshop on ADC Modelling and Testing Research on Electric and Electronic Measurement for the Economic Upturn Benevento, Italy, September 15-17, 2014.

Arrived: 02. 10. 2014

Accepted: 17. 11. 2014