

A Cooperative Control Strategy of the Hybrid Energy Recuperation System for Metro Trains

Ertao Lei¹, Xiaoyu Liu¹, Xin Yin², Xianggen Yin¹, Minghao Wen¹

¹ State Key Laboratory of Advanced Electromagnetic Engineering and Technology (Huazhong University of Science and Technology), Wuhan 430074, Hubei, China

² School of Electrical and Electronic Engineering, The University of Manchester, Manchester M13 9PL, U.K.
E-mail: leiertaot2008@163.com

Abstract. This paper presents a novel cooperative control strategy of the hybrid energy recuperation system (HERS) for regenerative braking energy recovery in metro trains. HERS consists of a wayside supercapacitor (SC) energy storage system and a voltage source converter (VSC). The regenerative energy is preferentially stored in SC during train electrical braking through large current charging to limit the contact line peak current. The excess energy is fed back to the auxiliary equipment in metro stations through VSC when SCs are fully charged. VSC is also working as STATCOM to achieve the reactive-power compensation for the metro traction substation. A scale-down simulation model of HERS is developed to verify the cooperative control strategy. The simulation results show that the voltage drop and surge during acceleration and braking are limited and the regenerative energy usage rate is improved. Furthermore, the power factor of the auxiliary power supply system is increased.

Keywords: urban mass transit system, regenerative braking, hybrid energy recuperation, cooperative control strategy

Regulacija hibridnega regenerativnega napajalnega sistema v podzemni železnici

V članku je predstavljena nova regulacijska metoda hibridnega regenerativnega napajalnega sistema (HRNS) podzemne železnice s poudarkom na učinkoviti izrabi zavorne energije. HRNS sestavljata superkondenzatorski hranilnik energije in napetostni močnostni pretvornik, ki nista del vlakovne kompozicije, temveč sta locirana ob železniški trasi. Ob zaviranju vlaka je smiselno z zavorno močjo sprva polniti superkondenzatorski hranilnik, s čimer omejimo maksimalen tok v napajanem vodu. Če kapaciteta superkondenzatorskega hranilnika ne zadostuje, višek energije preko napetostnega močnostnega pretvornika uporabimo za napajanje pomožne opreme v sistemu podzemne železnice. Napetostni pretvornik obenem služi tudi kot statični kompenzator, ki izboljšuje vhodni faktor delavnosti napajalne postaje.

Razvit je simulacijski model, s katerim verificiramo strategijo hibridnega regenerativnega napajalnega sistema. Simulacijski rezultati potrjujejo, da sta napetostni upad oz. porast med pospeševanjem oz. zaviranjem omejena, da je stopnja regeneracije zavorne energije večja ter da se izboljša faktor delavnosti napajalne postaje.

1 INTRODUCTION

Reduction of the energy consumption and control of the overhead contact line voltage in urban mass transit (UMT) systems have become a hot topic being studied so as to increase the energy efficiency and stabilize the contact line voltage. Nowadays, the traction load usually accounts for more than half of the power consumption in DC traction systems, while energy of regenerative braking is only used if there is another train powering at the same time near the same electrical section. Researches show that up to 40% of the consumed energy could be fed back to catenary [1]. Unfortunately, measurements show only 19% of recuperation [2]. This means that 21% of the regenerative energy is wasted by the ballast resistor bank on-board or mechanical brakes in heat. If not, the contact line voltage could increase to a dangerous level, because the AC-DC substations are usually not bidirectional in the power flow, which is a great threat to the whole traction system.

To increase the regenerated energy usage rate, there are several solutions suggested in the literature for the regenerative energy so far. These solutions can be classified into three categories: revising or optimizing the operation profile [3,4], applying energy storage

devices, such as supercapacitors (SC), flywheels (FW), or chemical battery (fuel-cell, lithium battery, etc.) [5,6], equipping substations with bidirectional inverters which allow to feed the DC energy regenerated by braking trains back into the AC network [7].

Revising or optimizing the speed profile of the trains along the route mainly adjusts the departure interval and coast points, which can partly reduce the peak power. However, it is difficult to make an accurate prediction of the number of passengers. Hence, the actual time coordination of the trains in the acceleration and deceleration phase at the same time is always unsatisfactory (less than 10%). So the energy storage system (ESS) becomes a more promising solution for energy saving in UMT. The regenerative energy is stored during braking and reused in the next acceleration [8]. Since the peak power is supplied by ESS, the contact line voltage drop can be limited during accelerations. The energy storage devices are always placed on-board, which simplifies the energy management since the control is independent of the traffic conditions. With respect to the solution with the on-board storage devices, the wayside storage devices reduce the mass of the train as much as possible. Besides, it can be expected that the supercapacitor-based energy storage system will not have enough capacity to store all the available potential energy. It is still necessary to configure a bulky resistor bank during braking. To realize the regenerative energy feeding back to the AC network, the bidirectional inverter is essential. However, it is expensive to replace the diode rectifier devices by the IGBT bridges, which also make the control strategy complex. Further, the voltage stability must not be ignored for the AC network feedback. Just like the grid-connected wind power, an intermittent or unstable energy feedback can lead to imbalance of the local voltage.

For these reasons, a combination of different methods becomes a viable technology applicable to the railway system. In literature [3,8], the energy storage devices and converters as well as resistors bank are placed on-board for the recuperation of the regenerative energy. Although it can avoid the transmission losses, the total mass of the trains is obviously increased and an additional place is required in the trains. Besides, if the flywheels are chosen as the energy storage devices, they will not be allowed to be placed on-board for safety reasons. Hence, the solution of placing ESS and inverter wayside in the substation is a favourable choice. On the one hand, the mass of the train is decreased, which can carry more passengers. On the other hand, the SC capacity limitation could be avoided because the excess energy which SC can't handle can be fed back to the auxiliary equipment in substations by a bidirectional inverter.

This paper presents a novel Hybrid Energy Recuperation System (HERS), combining wayside SC ESS and voltage source converter (VSC) feedback to the AC network. A cooperative control strategy for the

energy management of SC and feedback is also included, taking into account the lower power factor of the subway auxiliary system. The effectiveness of the proposed structure and control strategy is validated by simulation in MATLAB/Simulink. The result shows that the proposed solution can not only increase the regenerative energy usage rate but also stabilize the contact line voltage, and realize the reactive-power compensation for the auxiliary power supply system in the substation.

2 HERS CONFIGURATION

2.1 General Structure of HERS

The structure of HERS proposed in this paper is shown in Fig. 1. It mainly consists of five parts: SC energy storage bank, bidirectional chopper, voltage source converter (VSC), coupling transformer and cooperative control system. Fig.1 is a schematic overall topology, and the control system is not completely included.

When the trains are in the braking phase, the regenerative energy (except the energy used by trains in the acceleration phase at the same time) can flow to SC through a DC chopper as well as the auxiliary equipment (including lighting, air conditioning, communication, elevators, etc.) in a metro station through VSC. The capacity of the SC bank which is actually installed off-board is not enough due to economic considerations. (Nowadays, each energy storage system, such as the SIEMENS's *SITRAS SES* costs \$1,000,000 and its peak power is only 1MW, and the capacity is only $2.3 \text{ kW} \cdot \text{h}$.) According to the field measurements, the peak power of one train during regenerative braking can be 3MW, and the total energy can be about $12 \text{ kW} \cdot \text{h}$. Taking the Beijing subway Line 5 as an example, four sets of the SIEMENS's *SITRAS SES* have been installed along the line. There is still about 10% of the regenerative energy wasted by the brake resistor. Therefore, the SC capacity is not enough to store all the available braking energy. The regenerative energy can be fed back to the low-voltage distribution network for auxiliary equipment, especially when SCs are fully charged. This way, the regenerative energy cost in resistor banks on-board can be reduced as much as possible and the number of the resistor banks is decreased. VSC handles a part of the regenerative energy, which will help to reduce the number of the serial-parallel SCs. On the other hand, the regenerative energy can be stored in SC preferentially, which can help VSC to form a stable active-power feedback.

Since the weight increment of the train should be optimally reduced, it is important to point out that the proposed HERS is placed wayside or in the metro station instead of on-board.

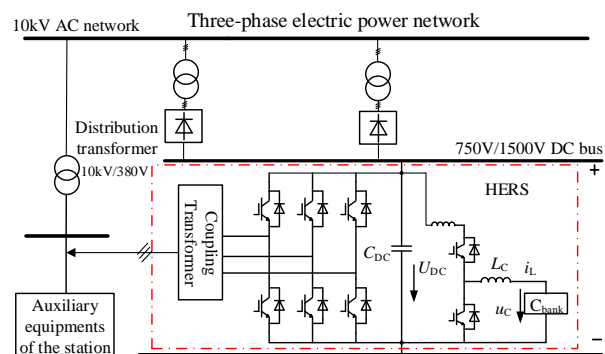

Figure 1. Block diagram of HERS

If both SC and resistor bank are placed on-board, just like in literature [3], the total mass of the train will increase to a high level and an extra space must be reserved irrespective of the safety reasons. Nowadays, a common configuration of a metro train has six cars in a train with four motor cars and two trailers. Research shows that the resistor bank of each car weighs about 800 kilograms. Then the total mass of the resistor bank on-board is m_{res_bank} (only the motor cars have a resistor bank).

$$m_{res_bank} = 4 \times 800kg = 3.2t \quad (1)$$

The size and weight of the SC bank on-board depends on its capacity (the number of SCs in series or parallel). Taking the *Bombardier's MITRAC* as an example, its dimension is $1.9 \times 0.95 \times 0.46$ meters and it weighs about 500 kilograms. If the accessories (forced-air cooling device, etc.) are included, the total weight loss of the train is about 5%~8%, which is not considerable. However, every ton of the added weight to a train equates to 10,000 kW·h of the energy cost per year (as reported by a technician of the Hong Kong Metro) [9]. It is still a lot of energy which can be saved especially when there are more trains running. A Lightweight metro is a general trend in modern mass transit. The reduction of the train weight means less energy consumption and larger passenger loads. So this paper chooses a wayside or metro station as the prior place.

2.2 SuperCapacitor Bank

The electrochemical batteries, SCs and FW are always chosen as the energy storage devices. For the electrochemical batteries, their specific energy and power are lower than those demanded by the train. In addition, their charging times (hours) are longer than the braking time intervals (several seconds) [8] and their mean lifetime is shorter. So, they are always used for back power applications. The Flywheels of the capacity of 3 MW have been in service in several countries. They seem to be a good choice for regenerative-energy utilization, but their maintenance might be complex and their safety questionable. The supercapacitors have a longer lifetime (up to ten years), higher storage

efficiency (up to 0.95) and power densities (1–6 kW/kg). As SCs permit a sudden large charging and discharging current, it is easier to design charging and discharging circuits and control strategy. Therefore, the supercapacitors are chosen as energy storage devices in HERS.

2.3 DC Chopper

Fig. 2 shows a simple Two-Quadrant type A chopper used in this paper, which works as a buck converter when it charges SC and as a boost converter when it discharges SC.

In order to stabilize the contact line voltage, the DC chopper mainly works in the following three modes:

- If contact line voltage U_{DC} falls below its lower limit U_{ref1} when the trains are in acceleration, the chopper is in the BOOST mode, where T_1 is off and T_2 is under a cyclic on/off switching control.
- If contact line voltage rises up to its upper limit U_{ref2} when the trains are braking, the chopper operates in the BUCK mode, where T_2 is off and T_1 is under a cyclic on/off switching control.
- If contact line voltage fluctuates within the permissible set, both T_1 and T_2 are blocked.

2.4 Three-phase Voltage Source Converter (VSC)

A three-phase VSC is designed to feed the energy which can not be stored in SCs to the AC network, especially when SCs are fully charged. Furthermore, the converter can work as STATCOM to compensate the reactive power. At the very beginning of braking, the regenerative peak power is stored in SCs through a large charge current until they are fully charged. Then the excess regenerative energy is gently fed back to the auxiliary equipment.

The converter applies a three-phase full IGBT bridge circuit, which can operate in four quadrants through PWM control technology. The converter can manage the voltage and current in the AC side to control the DC side and vice versa.

Regardless of the harmonic component and resistance of the AC side, the phasor diagram of the output voltage and current of the converter is shown in Fig. 3, where U_{pcc} and U_{inv} are the voltage of the point of common coupling and the output AC voltage of the converter respectively, while U_L and I are the voltage and current of the connection inductance.

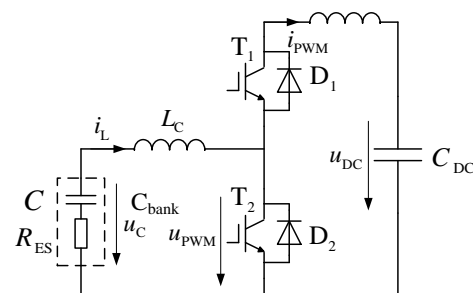

Figure 2. Two-Quadrant type A chopper

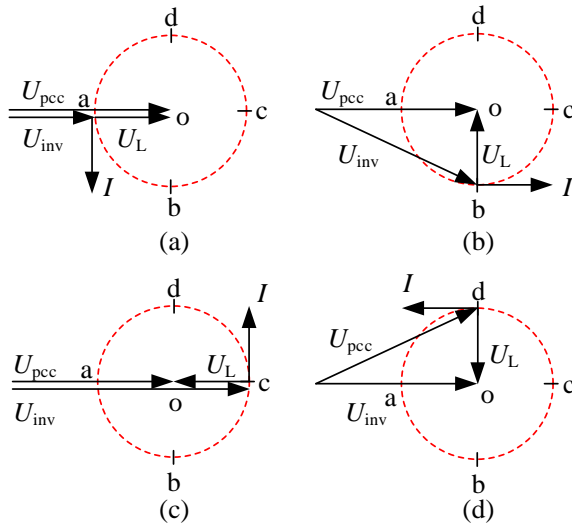

Figure 3. Phasor diagram of the voltage and current

(a) Lag 90° (b) In-phase (c) Lead 90° (d) Antiphase

Assuming that the amplitude of I is constant, the amplitude of U_L won't change so that the endpoint trace of phasor U_{inv} would be a circle, as shown in Fig. 3. For a different phase shift of I , the phasor diagrams are shown in Fig. 3(a)-(d). The active and reactive power exchanged between the low-voltage AC supply network and DC link can be managed by controlling the amplitude and phase of U_{inv} .

3 CONTROL STRATEGY OF HRES

3.1 Unified Control strategy of HERS

HERS is designed to stabilize the contact line voltage both in the acceleration and braking phase and to maximize the regenerative energy usage rate. To achieve the goals, a unified cooperative control strategy is implemented, as shown in Fig. 4. The controller detects the state of charge (SOC) of SC, instantaneous voltage V_{DC_bus} of the contact line, as well as voltage V_{load_abc} and current I_{load_abc} of the auxiliary electric load in metro stations. There are two kinds of the algorithms in the controller, i.e. the voltage-stabilization algorithm (VSA) and power-allocation algorithm (PAA). PAA and VSA are two important operating modes of the whole system.

The voltage stabilization algorithm mainly keeps the energy content of SC at a high level during braking and triggers discharging when the contact line voltage falls below a specified limit (for 750V DC, it is 500V). Meanwhile, the power-allocation algorithm controls the HERS working in the energy saving mode where both SC and VSC converter are controlled to optimally utilize the regenerative braking energy.

The braking energy handled by VSC and SCs would be controlled through allocation coefficients a and b , respectively. The constraint equation of a and b is given by the following relation:

$$a + b \leq 1 \quad (2)$$

Since SCs can be charged through a large current, for both PAA and VSA, the braking energy is stored in SC preferentially and b is usually greater than a .

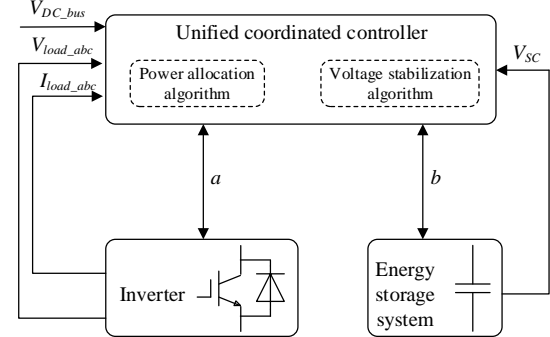

Figure 4. Schematic diagram of the unified coordinated controller

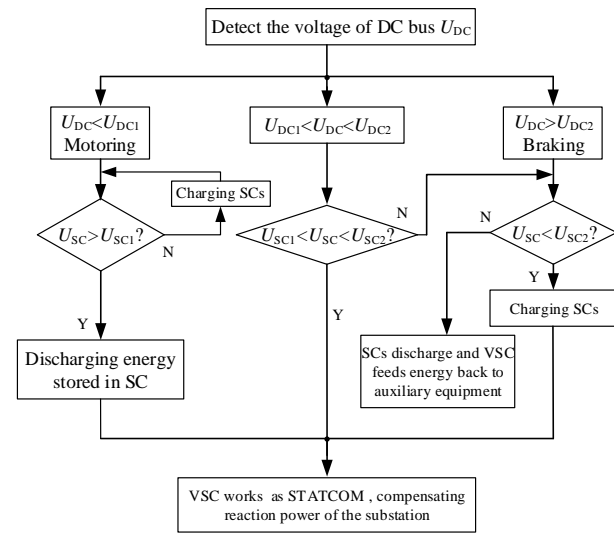

Figure 5. Flowchart of the cooperative control strategy

The variation range of the contact line voltage must be controlled strictly in order to prevent the surge voltage from damaging the equipment and the low voltage from triggering the low-voltage protection. A feasible control method is presented in Fig. 5. Actually, the trains start and brake frequently. The working life of SC should be considered, so its voltage has to be in the range of $[U_{sc1}, U_{sc2}]$ [10]. Similarly, the contact line voltage should also be limited in the range of $[U_{DC1}, U_{DC2}]$ (For the 750V DC system, it is $[500V, 900V]$). The possible operation modes are listed below:

- If $U_{DC} < U_{DC1}$ and $U_{SC} > U_{SC1}$, SCs discharge energy through a bidirectional chopper.
- If $U_{DC} > U_{DC2}$ and $U_{SC} < U_{SC2}$, SCs get charged through a bidirectional chopper.
- If $U_{DC} > U_{DC2}$ and $U_{SC} > U_{SC2}$, VSC works as an inverter, which feeds the braking energy back to the AC auxiliary system in the metro station.

- If $U_{DC1} < U_{DC} < U_{DC2}$ and $U_{SC1} < U_{SC} < U_{SC2}$, that is both the contact line voltage and SC voltage are right in their range, then the chopper is blocked and VSC works as STATCOM at the same time.
- If $U_{DC1} < U_{DC} < U_{DC2}$ and U_{SC} doesn't meet $U_{SC1} < U_{SC} < U_{SC2}$, the program jumps to judge whether the voltage for SC has reached its upper limit in the next step.

It should be noted that the total capacity of SCs should be increased if the mode of $U_{DC} < U_{DC1}$ and $U_{SC} < U_{SC1}$ often happens. In addition, VSC always operates as STATCOM to achieve the reactive-power compensation in most cases.

3.2 Control Method of the Bidirectional Chopper

The primary goal of the controller is to stabilize the contact line voltage and charge SCs until they are fully charged.

A dual-loop controller is implemented to control the chopper. Fig. 6 shows a control block diagram, in which two PI controllers are used. For a 750V DC traction system, the range of the contact line voltage is 500~900. The outer voltage loop controls the DC contact line voltage and generates the reference signal for the inner current loop. The inner current controller generates modulation signal u_{PWM_ref} . The popular PWM method is used to control the bidirectional chopper.

According to the unified control strategy, reference voltage u_{DC_ref} of the outer loop is not a constant. When a train accelerates, the contact line voltage drops and the reference voltage is set to a certain value a little higher than the lower limit (It is 500 for the 750V DC traction system). In our case, the value is set to 530V. When trains are in a braking phase, the contact line voltage swells and the reference voltage is set to a certain value slightly smaller than the upper limit considering the safety margin. In this paper, 860V are chosen as the reference value.

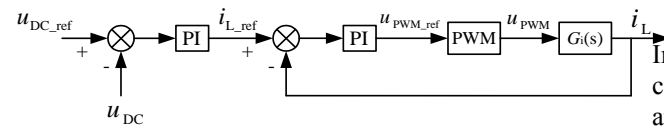

Figure 6. Control block diagram of the DC/DC converter

3.3 Control strategy of the Inverter

The wayside VSC is designed for an excess energy recuperation especially when SCs are fully charged, which is helpful to reduce the number of the SC banks and on-board braking resistor bank. For most operation modes, the converter works as STATCOM for the reactive-power compensation to increase the power factor of the metro traction substations.

This paper designs two decoupling control strategies for VSC, i.e. voltage-control strategy and active-power control strategy. PAA and VSA defined in subsection 3.1 correspond to the active-power control strategy and voltage-control strategy, respectively. Fig. 7 (a) shows a scheme of the voltage-control strategy. Compensating

current reference i_{q_ref} for the inner current loop is calculated by applying the transformation from abc to dq to the current of I_{load_abc} . Active current reference i_{d_ref} derives from the voltage controller. Fig. 7 (b) shows a scheme of the active-power control. The only difference is the access of i_{d_ref} acquired by the active-power controller. The inner current loop for both the voltage-control strategy and the active-power control strategy applies the same controller with different parameters.

The choice of different schemes is triggered in software by a unified coordinated controller (Fig. 4). When the inverter works as STATCOM, the voltage-control strategy would be chosen so as to maintain a stable DC bus voltage. When the inverter feeds the regenerative energy back to the auxiliary equipment, the active-power control strategy would be chosen to ensure a relatively stable power feedback.

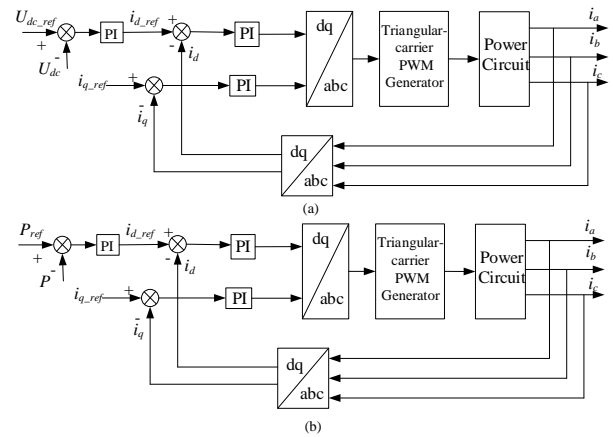

Figure 7. Control algorithm of the VSC inverter: (a) contact line voltage-control algorithm (b) active-power control algorithm

4 SIMULATION TESTS

In order to verify the effectiveness of the proposed control technique, a scale-down model of UMT is applied for simulations by using Matlab/Simulink.

4.1 Model and parameters of the simulations

The simulation model consists of several parts. A conventional 24-pulse rectifier is implemented to supply the traction energy to the trains. In most of the available literature, the motors of the trains are always simulated by a controlled current source, which is not close to the actual condition. So a Direct torque and flux control (DTC) induction motor drive model is implemented to simulate the traction load. Besides, the whole Variable Velocity Variable Frequency (VVVF) system and on-board resistor bank are included. The double layer supercapacitor model in [11] is connected to a buck/boost converter. A static load is applied to simulate the auxiliary equipment in a metro station. The main parameters of the model used for simulation are

reported in Table 1. The rotor speed of the traction motor is shown in Fig. 9.

Table 1. Main parameters for the simulations

| Items | Value |
|---|--------------|
| No-load rated voltage (V_{dc_bus}) | 750V |
| Rated motor power | 180kW |
| Number of motors | 6 |
| Total capacitance of SC | 1.7F |
| Total line resistance | 0.4 Ω |
| Auxiliary load | 70.7kVA |
| Power factor($\cos \varphi$) | 0.707 |
| Simulation time period | 1min |

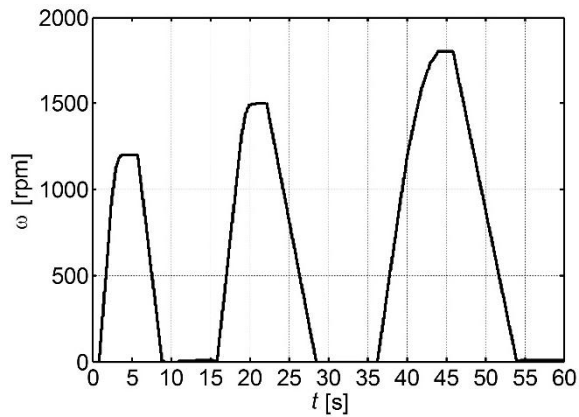

Figure 8. Rotor speed of the traction motor

4.2 Simulation results

The contact line voltage is shown in Fig. 9, from which the advantage of SC is evident. For the 750V DC traction system, the variation range of the contact line is [500, 900] referring to the relevant standards. If SCs are not configured, the contact line voltage drops below its limit value at 17s and 39s during acceleration. Similarly, if the braking resistor bank is not put into operation timely, the contact line voltage may increase above its upper limit during braking. When SCs are implemented, both the voltage drop and surge are limited. Besides, the normal voltage level of the contact line is increased, especially when SCs are working in the energy-saving mode. The peak power required is partially saved. But Fig. 9 also presents that the surge voltage may exceed the upper limit in a short time if the total capacity of SCs is not enough to handle all the regenerative braking energy (provided that all the on-board rheostats are not applied and most of the trains are in the braking phase at worst). In this scenario, for HERS, the excess energy will be fed back to the auxiliary equipment in the stations through VSC.

The SC current is shown in Fig. 10 (a), while the state of charge (SOC) of SC is shown in Fig. 10 (b).

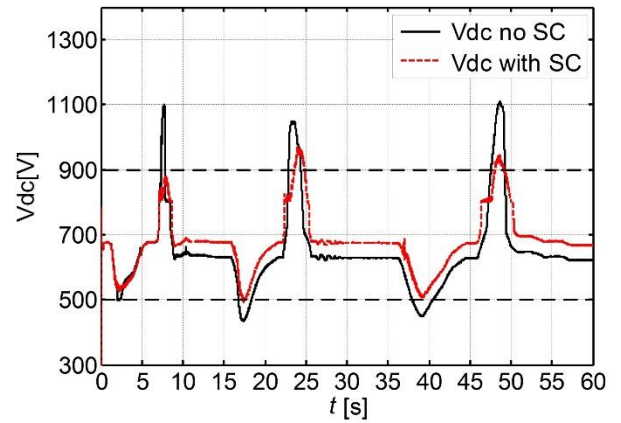

Figure 9. Contact line voltage

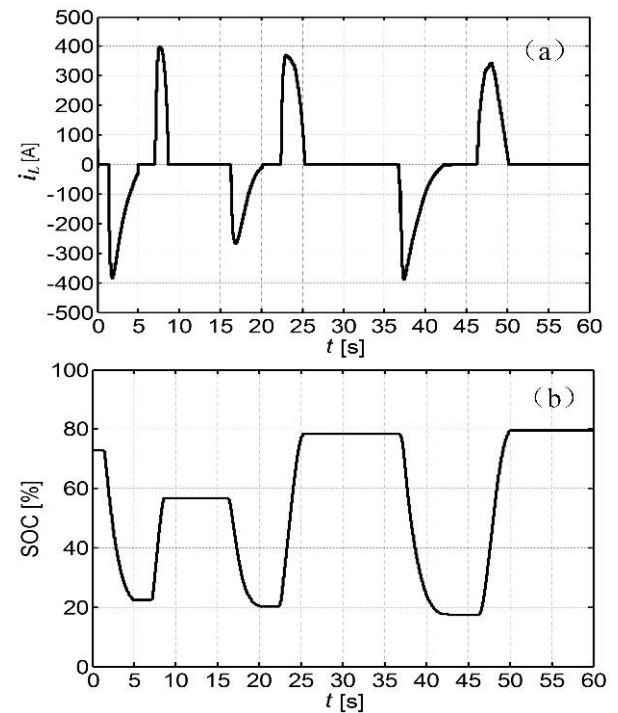

Figure 10. SC simulation results: (a) SC current (b) SC state of charge

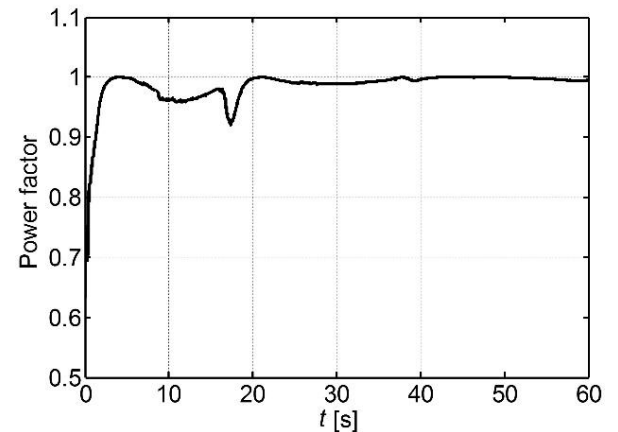

Figure 11. Power factor of the auxiliary power-supply system

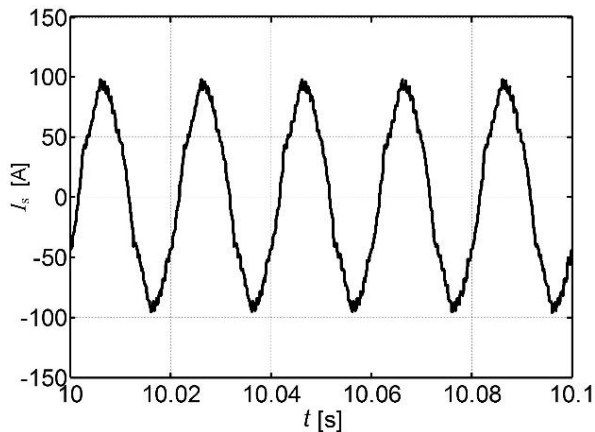

Figure 12. Current of the auxiliary power-supply system

As mentioned above, VSC is commonly working as STATCOM to compensate the reactive power following a decrease in losses and an improvement of the power quality. The power factor (PF) of the auxiliary power-supply system is shown in Fig. 11. The PF is increased from 0.707 to above 0.9. The inherent weaknesses of VSC are harmonic problems. Fig. 12 shows the current of the auxiliary power-supply system. To a certain extent, distortion of the current waveform may limit the applications of HERS and additional filter devices may be necessary. However, for HERS, the power circuit of VSC consists of the IGBT bridges. The switching frequency is generally somewhere between 5k and 40 kHz. The more mature and reliable PWM control technology has been widely used. Hence, the filter design may be greatly simplified. So, the harmonic is no longer a severe problem.

5 CONCLUSION

This paper presents a hybrid energy recuperation system of SC integrated with energy feedback through the inverter. The SC capacity limitation can be partially avoided, which can help to increase the regenerative energy usage rate. The cooperative control strategy is flexible to realize the power flow of SCs and inverter. The braking energy is preferentially stored in SCs at the very beginning of braking and released during acceleration. When SCs are fully charged, the spare energy can be fed back to the low-voltage distribution network for the auxiliary equipment instead of being wasted by the resistor bank. Moreover, the inverter can operate as STATCOM to improve the power factor of the auxiliary power supply network in metro stations. The simulation results show that using the proposed method increases the regenerative energy usage rate and consequently reduces the voltage drops during acceleration and the surge voltage during braking.

ACKNOWLEDGEMENT

This work was supported in part by the National Natural Science Foundation of China under Grant 51277084 and Grant 51177058.

REFERENCES

- [1] S. Açıkbaz and M. T. Soylemez. Parameters affecting braking energy recuperation rate in DC rail transit: American Society of Mechanical Engineers, 2007. 263.
- [2] A. Adinolfi, R. Lamedica, C. Modesto, A. Prudenzi and S. Vimercati. Experimental assessment of energy saving due to trains regenerative braking in an electrified subway line, *IEEE Transactions on Power Delivery*, 13(4): 1536, 1998.
- [3] M. Dominguez, A. Fernandez-Cardador, A. P. Cucala and R. R. Pecharroman. "Energy Savings in Metropolitan Railway Substations Through Regenerative Energy Recovery and Optimal Design of ATO Speed Profiles", *IEEE Transactions on Automation Science and Engineering*, 9(3): 496, 2012.
- [4] S. Acikbas and M. T. Soylemez. "Coasting point optimisation for mass rail transit lines using artificial neural networks and genetic algorithms", *Electric Power Applications, IET*, 2(3): 172, 2008.
- [5] P. Garcia, L. M. Fernandez, C. A. Garcia and F. Jurado. "Energy Management System of Fuel-Cell-Battery Hybrid Tramway", *IEEE Transactions on Industrial Electronics*, 57(12): 4013, 2010.
- [6] M. B. Richardson. "Flywheel energy storage system for traction applications", *Proceedings of International Conference on Power Electronics Machines and Drives*, Bath, UK, 2002. pp. 275-279.
- [7] M. C. Falvo, R. Lamedica, R. Bartoni and G. Maranzano. "Energy saving in metro-transit systems: Impact of braking energy management", *Power Electronics Electrical Drives Automation and Motion (SPEEDAM)*, 2010 International Symposium on, Pisa, 2010. pp. 1374-1380.
- [8] D. Iannuzzi and P. Tricoli. "Speed-Based State-of-Charge Tracking Control for Metro Trains With On-board Supercapacitors", *IEEE Transactions on Power Electronics*, 27(4): 2129, 2012.
- [9] H.D., Liu, B.H., Mao, Y. Ding, W. Jia, and S.K., Lai "Train energy-saving scheme with evaluation in urban mass transit systems." *Journal of Transportation Systems Engineering and Information Technology* 7(5): 68-73, 2007.
- [10] Z. Cheng, W. Chen, Q. Li, Z. Jiang and Z. Yang. "Modeling and Dynamic Simulation of an Efficient Energy Storage Component- Supercapacitor", *Power and Energy Engineering Conference (APPEEC)*, 2010 Asia-Pacific, Chengdu: IEEE, 2010. pp. 1-4.
- [11] K. B. Oldham. "A Gouy - Chapman - Stern model of the double layer at a (metal)/(ionic liquid) interface", *Journal of Electroanalytical Chemistry*, 613(2): 131, 2008.

Ertao Lei is currently working towards his Ph.D. degree at Huazhong University of Science and Technology, Wuhan, China.

His research interests include power-electronics application technology and protective relaying.

Xiaoyu Liu is currently working towards his Master degree at Huazhong University of Science and Technology, Wuhan, China.

His research interests include power-electronics application technology and protective relaying.

Xin Yin is currently working towards his Ph.D. degree at The University of Manchester, Manchester M13 9PL, U.K.

His research interests mainly include cooperative control for complex industrial systems and monitoring of power grid with distributed generation.

Xianggen Yin (M'07) received his Ph.D. degree in electrical engineering from the School of Electrical and Electronic Engineering, Huazhong University of Science and Technology, Wuhan, China, in 1989. Currently, he is a Professor of the same School.

His research interests include protective relaying and power-system stability control, and power-electronics application technology.

Minghao Wen received his Ph.D. degree in electrical engineering from the School of Electrical and Electronic Engineering, Huazhong University of Science and Technology, Wuhan, China, in 2000. Currently, he is an Associate Professor of the same School.

His research interests include protective relaying and power-system analysis and control.