

Speed-Control of Energy Regulation Based Variable-Speed Electrohydraulic Drive

Ming Xu^{1,*} – Bo Jin² – Guojin Chen¹ – Jing Ni¹

¹ Hangzhou Dianzi University, Department of Mechanical Engineering, China

² Zhejiang University, State Key Laboratory of Fluid Power Transmission and Control, China

The variable-speed electrohydraulic drive is a promising drive principle due to its high energy efficiency and large speed-range. However, its slow response and poor low-speed behaviour limit its application. To address these disadvantages, a energy regulation based variable-speed electrohydraulic drive is proposed. This novel drive principle is combined with the advantages of variable-speed drive and valve-control drive. The speed-control of the energy regulation based variable-speed electrohydraulic drive is discussed. The speed-control strategy, which is aimed at the multiple-input multiple-output (MIMO) structure of the proposed drive principle, is analysed. The results of simulations and experiments comparing it with three other drive principle systems show that the proposed drive principle has not only a good speed-control accuracy, but also a perfect energy-saving performance.

Keywords: variable-speed, speed-control, energy regulation, energy-saving

0 INTRODUCTION

With the developments in frequency converters, the variable-speed electrohydraulic drive (a speed-controlled electric motor in combination with a hydraulic constant pump) has been greatly improved. A review of the literature [1] shows the development of the variable-speed drive. References [2] to [7] discuss the energy-saving performance of variable-speed drive, while references [8] to [11] discuss the control strategy. In addition to the high energy efficiency of the volume drive (a constant-speed electric motor in combination with a hydraulic variable-displacement pump), the variable-speed drive can enhance system reliability and expand the speed-range [12]. However, due to the large inertia of the electric motor and hydraulic pump, the main disadvantages of the variable-speed drive are slow response and poor control precision [13].

To address these disadvantages, a flow valve was added into the variable-speed (AKA variable-frequency) drive system to create a compound drive, in which the frequency converter adjusts the speed of the electric motor to satisfy the actuator's flow requirement and the flow valve controls the actuator's position or speed. The compound drive principle can improve control precision and low-speed performance [14]. In the low-speed range, the hydraulic pump maintains a constant speed to gain sufficient flow, while the flow-valve drives the actuator. The compound drive can also improve the deceleration response owing to the fast dynamic response of the flow valve, although it is unable to improve the response when accelerating [13]. Therefore, it

is mainly applied in hydraulic elevators, injection machines, etc., which do not require a fast response.

A energy regulation based variable-speed electrohydraulic drive has been proposed in order to improve responsiveness, especially when accelerating [12]. This drive is distinguished from the compound drive by the inclusion of an energy regulation device (ERD). The electric motor-pump cannot always speed up as needed when accelerating, so the ERD releases energy to improve the acceleration response. When decelerating but the electric motor-pump cannot always slow down as needed, so the ERD absorbs redundant hydraulic oil. In other cases, the ERD is turned off.

The position-control of the variable-speed drive based on energy regulation has been studied [13], although the speed-control has not. Speed-control is widely used in hydraulic systems, such as hydraulic cutting machine, hydraulic elevators, and so on. The key issues associated with speed-control research for hydraulic systems, in addition to energy savings, are how to deliver high speed-control accuracy and a fast acceleration response. The goal of this research is to develop a novel electrohydraulic drive principle for speed-control, which is useful for practical application.

1 SYSTEM STRUCTURE

Fig. 1 shows the cylinder speed-control in a variable-speed drive system based on energy regulation. A hydraulic constant pump is driven by a frequency converter via an asynchronous electric motor. The cylinder is controlled by a proportional directional valve. The position of the cylinder along its stroke

*Corr. Author's Address: Hangzhou Dianzi University, Department of Mechanical Engineering, Hangzhou, China, xumzju@163.com

is measured by a position sensor mounted inside the cylinder. The cylinder velocity is calculated by differentiating the position signal, because there is no suitable speed sensor for this system. The pressures p_s and p_e are measured by two pressure sensors. The flow of the hydraulic pump outlet is measured by a high-pressure flowmeter.

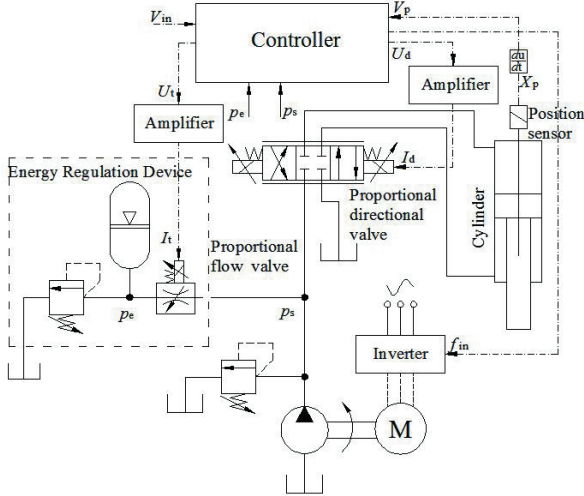

Fig. 1. Cylinder speed-control of a variable-speed drive system based on energy regulation

The ERD, mounted on the hydraulic pump outlet, is composed of a bladder accumulator, a proportional flow valve, and a relief valve. Due to its simple structure and fast response characteristics, the bladder accumulator was chosen for storing hydraulic energy. The flow between the ERD and the main hydraulic circuit is controlled by the proportional flow valve. The relief valve is used as a safety valve. The ERD is a semi-active device because its function depends on the pressure difference between the ERD and the hydraulic pump outlet.

Fig. 2 shows a multifunctional test-rig where experiments for four different drive principles can be implemented.

- (1) Valve control. The ERD is closed. The electric motor speed is 1500 r/min at all times. The proportional directional valve controls the speed of the cylinder rod.
- (2) Variable-speed drive. The ERD is closed. The speed of the hydraulic constant pump can be adjusted. The proportional directional valve controls the movement direction of the cylinder without throttling.
- (3) Compound drive. The ERD is closed. The proportional directional valve and the speed-

controlled hydraulic constant pump control the cylinder rod together.

- (4) Variable-speed drive based on energy regulation.



Fig. 2. Energy regulation test-rig

As shown in Fig. 1, the controller is composed of an industrial computer, an analogue-to-digital converter (ADC), and a digital-to-analogue converter (DAC). The Visual C++ was selected as the programming environment. The control voltage of the proportional directional valve's amplifier is from -10 to +10 V. For the proportional flow valve of the ERD, it is from 0 to 5 V. The main parameters of the test-rig are shown in Table 1. The control period indicates that the control process is executed per 0.01 s.

Table 1. Main parameters of the test-rig

Parameters	Value
Power of the frequency converter P_f [kW]	15
Electric motor nominal power P_M [kW]	15
Electric motor nominal speed n_m [r/min]	1 500
Pump displacement s_p [cm ³ /rad]	3.185
Cross-sectional area of no rod-side A_{p1} [dm ²]	0.313
Cross-sectional area of rod-side A_{p2} [dm ²]	0.153
Cylinder-rod stroke S [m]	0.3
Piston mass m [kg]	50
Accumulator volume V_{a0} [dm ³]	6.3
Accumulator precharge pressure p_{e0} [MPa]	2
Relief valve cracking pressure p_{cr} [MPa]	4
Nominal flow of the flow valve ($\Delta p = 0.5$ MPa)	0.533
q_{tnom} [dm ³ /s]	
Nominal flow of the directional valve ($\Delta p = 0.5$ MPa)	0.533
q_{dnom} [dm ³ /s]	
Effective bulk modulus of hydraulic oil E_h [MPa]	700
Density of hydraulic oil ρ [kg·m ³]	850
Control period t_c [s]	0.01

The parameters of the ERD (such as accumulator volume, precharge pressure, etc.)

have been studied [12] and they are very important for energy regulation. However, the aim of this research is to demonstrate the applicability of ERD in cylinder speed-control, not to have a general discussion of ERD.

2 SPEED CONTROL STRATEGY

Fig. 3 shows the MIMO scheme of the cylinder speed-control system in a variable-speed drive system based on energy regulation. There are four inputs (v_{in} , v_p , p_s , p_e) and three outputs (f_{in} , u_d , u_t).

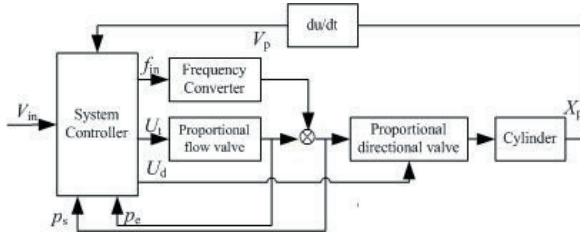

Fig. 3. Speed-control principle of the variable-speed drive system based on energy regulation

The speed-control strategy can be explained as following.

- (1) If $v_{in} > v_p$, the cylinder needs to accelerate. f_{in} and u_d should be increased. If $p_e > p_s$, the ERD will be open to release energy. If $p_e < p_s$, the ERD is closed.
- (2) If $v_{in} < v_p$, the cylinder needs to decelerate. f_{in} and U_d should be reduced. If $p_e > p_s$, the ERD is closed. If $p_e < p_s$, the ERD absorbs energy.
- (3) If $v_{in} = v_p$, the electric motor maintains the current speed and the proportional directional valve is used for speed-control. If $p_e > p_s$, the ERD is closed. If $p_e < p_s$, the ERD absorbs energy.
- (4) If v_{in} is very small, the electric motor maintains the preset minimum speed v_{m0} . The proportional directional valve is used for speed-control. If $p_e > p_s$, the ERD is closed. If $p_e < p_s$, it absorbs energy.

The detailed strategies of the three controlled-objects are discussed as below.

- (1) Frequency converter.

The frequency converter adopts the “Input-Feedforward + Proportional-Integral-Differential (PID) control.” The input-feedforward plays a major role in reference tracking. And the PID corrects the error caused by load disturbance. The expression for the frequency converter is shown in Eq. (1).

$$f_{in} = \min[\max(|K_{in} \cdot V_{in} + u(k)|, f_{inmin}), f_{inmax}], \quad (1)$$

where

$$u(k) = k_{fp} \cdot e(k) + \lambda_f k_{fi} \sum e(i) + k_{fd} [e(k) - e(k-1)],$$

$$\lambda_f = \begin{cases} 1 & e(k) \leq e_f \\ 0 & e(k) > e_f \end{cases}$$

- (2) Proportional directional valve.

The proportional directional valve uses a PID control strategy.

$$u_d = \min(\max((k_{dp} \cdot e(k) + \lambda_d k_{di} \sum_{i=0}^k e(i) + k_{dd} \cdot [e(k) - e(k-1)]), -10), 10), \quad (2)$$

where $\lambda_d = \begin{cases} 1 & e(k) \leq e_d \\ 0 & e(k) > e_d \end{cases}$.

- (3) ERD.

The ERD uses “PID + Logical judgment.” In Eq. (3), v_{m0} is the smallest speed of the cylinder rod. It is determined by the allowable minimum-speed of the electric motor.

$$u_t = \begin{cases} k_{tp} \cdot e(k) + \lambda_e k_{ti} \cdot \sum_{i=0}^k e(i) + k_{td} \cdot [e(k) - e(k-1)] & v_{in} > v_p, P_e > P_s \\ k_{tp} \cdot e(k) + \lambda_e k_{ti} \cdot \sum_{i=0}^k e(i) + k_{td} \cdot [e(k) - e(k-1)] & v_{in} < v_p, P_e < P_s \\ k_{tp} \cdot e(k) + \lambda_e k_{ti} \cdot \sum_{i=0}^k e(i) + k_{td} \cdot [e(k) - e(k-1)] & v_{in} = v_p, P_e < P_s \\ k_{tp} \cdot e(k) + \lambda_e k_{ti} \cdot \sum_{i=0}^k e(i) + k_{td} \cdot [e(k) - e(k-1)] & v_{in} < v_{m0}, P_e < P_s \\ 0 & \text{others} \end{cases} \quad (3)$$

where $\lambda_e = \begin{cases} 1 & e(k) \leq e_e \\ 0 & e(k) > e_e \end{cases}$.

There are a lot of control parameters, shown in Eqs. (1) to (3) and Fig. 4, which need to be determined before simulations and experiments are carried out. Fig. 4 shows the setting order of these parameters.

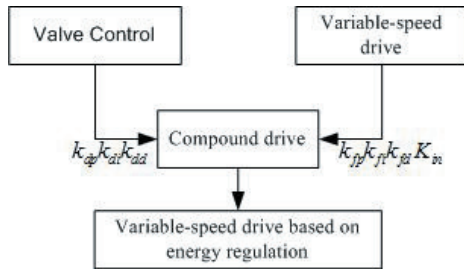

Fig.4. Setting order of control parameters

The setting rules of the control parameters are explained below.

- (1) In the valve-control drive system, the control parameters are k_{dp} , k_{di} , k_{dd} and e_d . The PID parameters k_{dp} , k_{di} , k_{dd} were determined by the Ziegler-Nichols method. The parameter e_d was obtained by experimentations.
- (2) In the variable-speed drive system, the control parameters are K_{in} , k_{fp} , k_{fi} , k_{fd} , e_f . The input-feedforward parameter K_{in} equals the reciprocal of the actuator's speed-gain. In a variable-speed drive, the frequency converter controls the speed of the hydraulic cylinder throughout. If the frequency converter has an input frequency of f_{in} , the hydraulic cylinder has a steady-state speed of v , accordingly. The cylinder's speed-gain is defined as v/f_{in} . K_{in} is therefore defined as f_{in}/v . The PID parameters k_{fp} , k_{fi} , k_{fd} were also determined by the Ziegler-Nichols method, whereas the parameter e_f was obtained by experimentations.
- (3) In the compound drive system, the control parameters of the directional valve k_{dp} , k_{di} , k_{dd} , e_d were the same as those in the valve-control drive system. The control parameters of the frequency converter K_{in} , k_{fp} , k_{fi} , k_{fd} , e_f were the same as those in the variable-speed drive system.
- (4) In the variable-speed drive system based on energy regulation, the control parameters of the direction valve (k_{dp} , k_{di} , k_{dd} , e_d) and the frequency converter (K_{in} , k_{fp} , k_{fi} , k_{fd} , e_f) were the same as in the compound drive system. The PID parameters of the ERD (k_{ip} , k_{ii} , k_{id} , e_i) were determined by experimentations.

Table. 2. Ziegler-Nichols Method

Control Type	k_p	k_i	k_d
P	$0.5 k_{max}$	0	0
PI	$0.45 k_{max}$	$1.2 f_0$	0
PID	$0.6 k_{max}$	$2.0 f_0$	$0.125 / f_0$

The parameter determination method is based on the principle of the Ziegler-Nichols method. This method firstly sets the integral and differential gain to zero, and then gradually increases the proportional gain until system oscillation occurs. At this time, the value of the unstable proportional gain is k_{max} , and the oscillation frequency is f_0 . Table 2 shows the Ziegler-Nichols method.

3 SIMULATION RESULTS

To demonstrate the speed-control performance of the variable-speed drive based on energy regulation, some simulations and experiments were carried out. In order to compare the speed-control performance, the simulations and experiments of the valve-control drive, variable-speed drive and compound drive principles are also implemented.

AMESim was chosen to carry out the simulations. The components of the model are described using analytical models representing the hydraulic, pneumatic, electric or mechanical behaviour of the system. To create the system simulation model in AMESim, the user can make use of a large set of validated libraries of pre-defined components from different physical domains.

The expression of each controlled-object in the above three drive principle systems is the same as it is in the proposed drive principle system. Correspondingly, the conditions of the simulations and experiments are the same, as well as the control parameters. Numbers 1 through 4 represent the valve-control, variable-speed drive, compound drive, and energy regulation drive, respectively, without specification, in the following texts and figures.

In simulations, the cylinder stroke is assumed to be 1 meter for convenience. Fig. 5 shows the velocity response of the cylinder using the four drive principles on a rectangular reference signal. Curve 4 coincides with Curve 1 exactly when accelerating because the ERD releases hydraulic oil to accelerate the cylinder response. This clearly shows that the tracking performance of the proposed drive principle is better than that of the variable-speed drive and compound drive. Curves 2 and 3 are almost the same because their accelerations depend on the electric motor. When decelerating, the proportional directional valve can shut down rapidly, so the four curves are almost the same. The upward and downward curves of each drive principle system are not the same due to the asymmetry of the single-rod hydraulic cylinder.

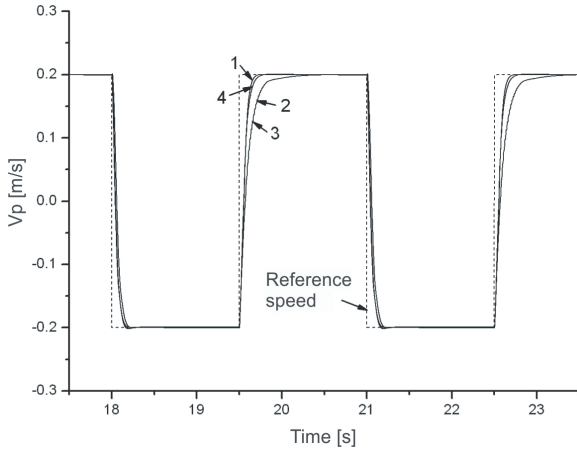

Fig. 5. Velocity simulations of the cylinder using the four drive principles on a rectangular signal

The hydraulic power consumption of the systems using four different drive principles are shown in Fig. 6. They are calculated by:

$$P_s = p_s \cdot Q_s \cdot \quad (4)$$

The hydraulic power of the valve-control system is always highest. The hydraulic power in the variable-speed drive is the lowest, most of the time. When the direction of the cylinder movement changes, the hydraulic power increases rapidly because of the pressure shock. The hydraulic power of Curve 4 is smaller than that of Curve 3 because the ERD can absorb hydraulic oil so as to keep the hydraulic power from overflowing and throttling when the cylinder decelerates or maintains a constant speed. Table 3 shows the average hydraulic power consumption of each system.

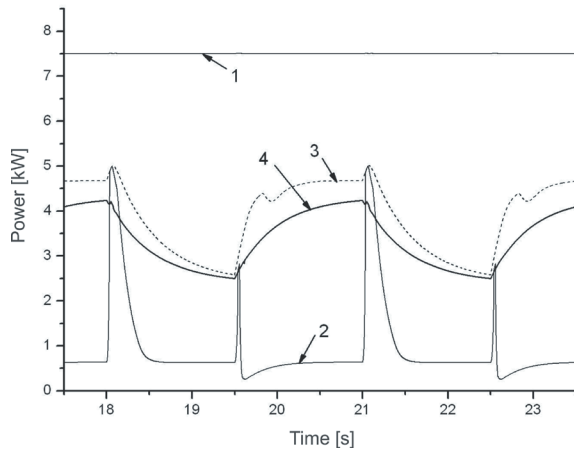

Fig. 6. Hydraulic power consumption simulations of the four drives principles on a rectangular signal

Table 3. Average hydraulic power simulations using the four drive principles on a rectangular signal

System	1	2	3	4
Average hydraulic power [kW]	7.50	0.87	3.82	3.30

Fig. 7 shows the performance of flowrate compensation in a variable-speed drive based on energy regulation. The positive flowrate represents the ERD as it releases oil. The negative flowrate represents the ERD as it absorbs oil. The ERD therefore plays the role of regulating energy consumption according to the system's requirements.

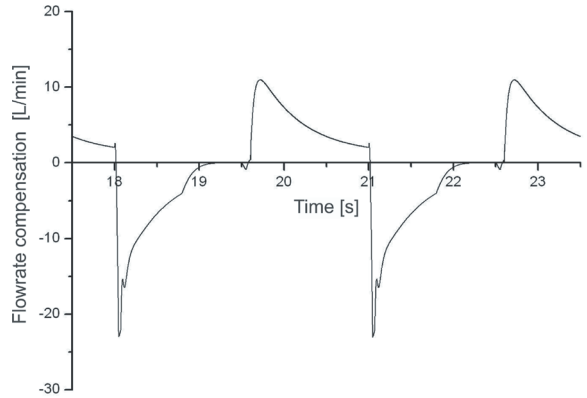

Fig. 7. The flowrate compensation effect in a variable-speed drive based on energy regulation

To analyse the speed-control performance comprehensively, simulations on the sine reference signal were also carried out. Because the cylinder stroke is only 0.3 meter, the four drive principle systems have the smallest work-frequency below the designated speed.

If the reference speed of the cylinder is:

$$v_{in} = v_A \cdot \sin(\omega t + \theta), \quad (5)$$

and $\theta = 0$,

$$v_{in} = v_A \cdot \sin(\omega t) \quad (6)$$

where

$$\omega t \in [2k\pi, (2k + 1)\pi] \text{ or } \omega t \in [(2k + 1)\pi, (2k + 2)\pi],$$

($k = 0, 1, 2, \dots$), then the actual displacement of the piston rod is:

$$s = \int_0^{\pi/\omega} v_{in} dt = \int_0^{\pi/\omega} v_A \cdot \sin(\omega t) dt, \quad (7)$$

and

$$s \leq l. \quad (8)$$

From Eqs. (5) to (8), the lowest work-frequency is where $l = 0.3 \text{ m}$ and $v_A = 0.2 \text{ m/s}$: $f_{\min} = 0.21 \text{ Hz}$.

If the frequency is smaller than 0.21 Hz, the piston rod will collide with the cylinder block. Therefore, the frequency of the sine reference signal can be taken to be 0.25 Hz.

Fig. 8 shows the velocity response of the four drive principle systems under the condition of $v_A = 0.2 \text{ m/s}$ and $f = 0.25 \text{ Hz}$. Although the simulation results for the tracking performance look similar for all of the four drive principles, there are differences. The total error of tracking performance in a cycle is $2 > 3 > 4 > 1$. Table 4 shows the mean square error (MSE) of the four drive principles.

Table 4. MSE of sine simulations using the four different drive principles

System	1	2	3	4
MSE [$10^{-4} \text{m}^2/\text{s}^2$]	0.551	1.283	1.148	0.847

It Table 4 $MSE = \frac{1}{n} \sum_{i=0}^n (v_{in}(i) - v_p(i))^2$, n is the numerical value of the sampling times.

Table 5 shows the average hydraulic power consumption of the four drive principle systems. Because the electric motor has a preset minimum speed in energy regulation drive, the average hydraulic power of the energy regulation drive is a little greater than that of the compound drive.

Table 5. Average hydraulic power of the sine simulations using four different drive principles

System	1	2	3	4
Average hydraulic power [kW]	7.50	0.26	1.79	2.26

Fig. 9 shows the spectrums of speed-amplitude simulations using four different drive principles (the speed-amplitude is 0.2 m/s). The bandwidth of Curves 2 and 3 are almost the same. According to common sense, the bandwidth of the energy regulation drive principle system should be the smallest out of all four drive principle systems due to the large volume (6.3 l) of the accumulator. However, Curve 4 still has good bandwidth characteristics, which is attributed to the energy regulation performance.

Fig. 10 shows the spectrums for hydraulic power simulations using four different drive principles. The hydraulic power of System 1 is greater than the other three systems. In the high frequency region, the electric motor always maintains a high speed and does not slow down in a timely manner. Therefore Curves 2 to 4 almost coincide. The hydraulic power of Curve 4

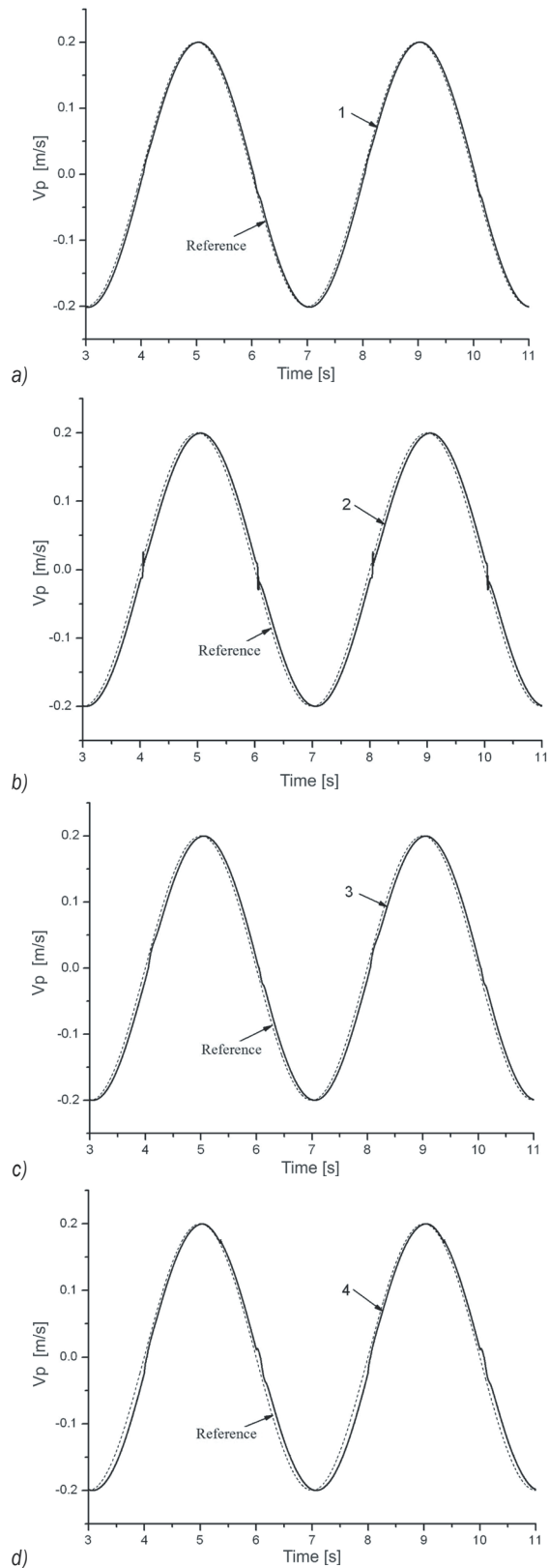

Fig. 8. Sine simulations of the cylinder using four different drive principles; ; a) to d)

is always bigger than that of Curve 3, because there is a preset minimum-speed in System 4.

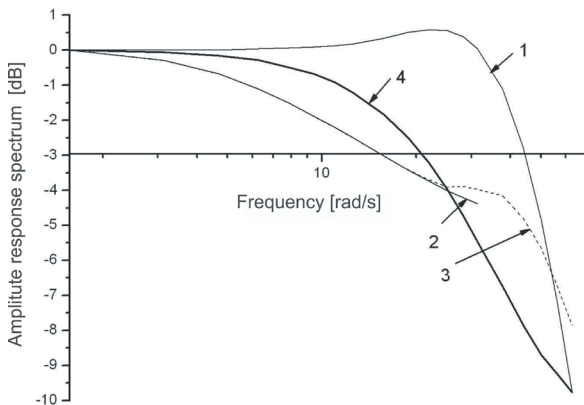

Fig. 9. Spectrums of speed-amplitude simulations of the cylinder using four different drive principles

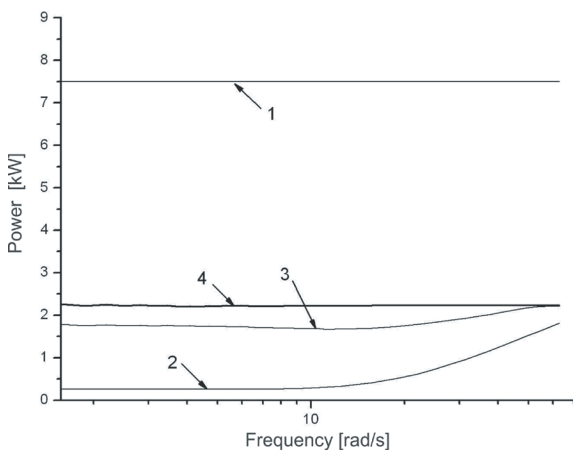

Fig. 10. Spectrum of hydraulic power simulations of the cylinder using four drive principles

4 EXPERIMENTAL RESULTS

Since there are not any suitable speed sensors for this test-rig, the cylinder velocity is calculated by differentiating the position signal. However, this causes high-frequency interference. To calculate the cylinder velocity accurately, a Butterworth filter of order 10, whose cutoff frequency is 150 Hz, was designed by using the Filter Design&Analysis Tool of MATLAB. A moving-average filtering algorithm is also employed to reduce random interference.

Since the cylinder stroke is only 0.3 m, the piston can only move in one direction during a signal period. Fig. 11 shows the velocity tracking experiments of the cylinder using the four drive principles on a rectangular signal. Curve 4 coincides with Curve 1 exactly and their responses are obviously faster than those of Curves 2 and 3. When decelerating, the

four drive principle systems have almost the same responses because their decelerations basically depend on the proportional directional valve.

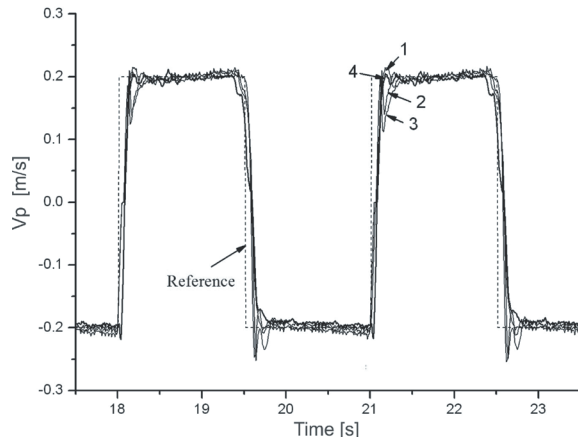

Fig. 11. Velocity experiments of the cylinder using the four drive principles on a rectangular signal

Fig. 12 shows the p_s and p_e in the energy regulation drive principle system. When the cylinder accelerates, the ERD releases hydraulic oil. When the cylinder decelerates or maintains a constant speed, the ERD absorbs hydraulic oil.

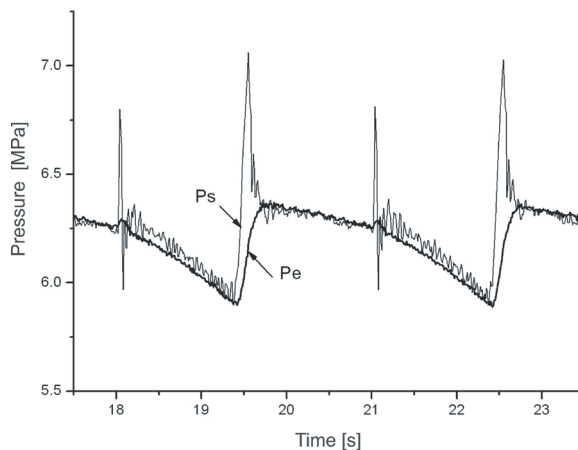

Fig. 12. p_e and p_s in the energy regulation drive

Fig. 13 shows the electric motor speed in the energy regulation drive. It can be seen that the acceleration time of the electric motor is long (about 0.2 s from 460 r/min to 900 r/min). Therefore, the flow discharged by the hydraulic pump cannot meet the requirements of the cylinder speed-control in a timely manner.

Fig. 14 compares the hydraulic power consumption of four drive principles. The hydraulic power in System 1 is consistently the highest. The other three systems have almost the same power

consumption. Because the electric motor has the preset minimum-speed in System 4, the hydraulic power in System 4 is a little bigger than that in Systems 2 and 3. Due to the pressure shock caused by the change in direction of the cylinder motion, the four curves have power shocks.

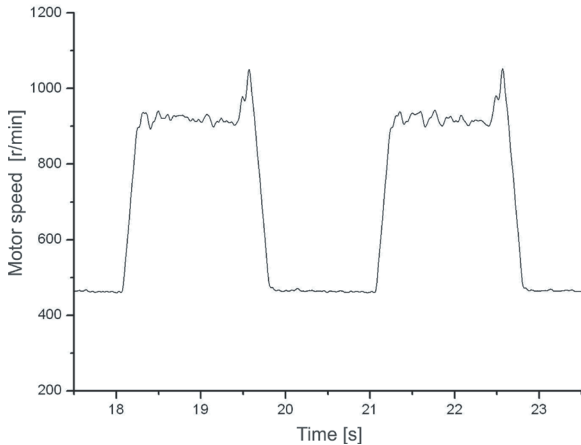

Fig. 13. Speed of the electric motor in the energy regulation drive

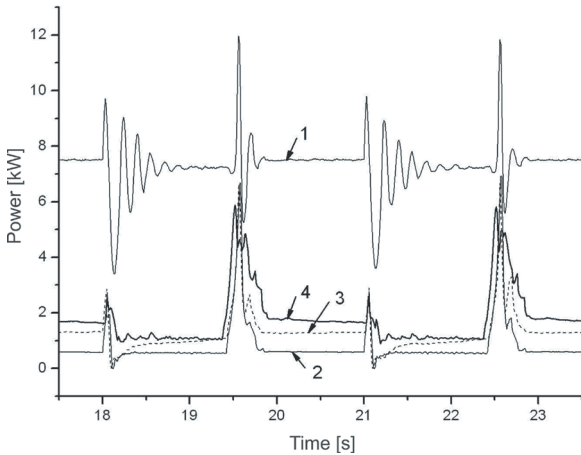

Fig. 14. Hydraulic power experiments using four drive principles on a rectangular signal

Fig. 15 shows the velocity experiments on the cylinder using four different drive principles on the sine reference signal. The speed-tracking error is very small in System 4, which is approximately equivalent to Curve 1.

Table 6 shows the mean square error of the four drive principles.

Table 6. MSE of the sine experiments using the four different drive principles

System	1	2	3	4
MSE $\times 10^{-4}$ [m ² /s ²]	1.672	2.157	1.996	1.743

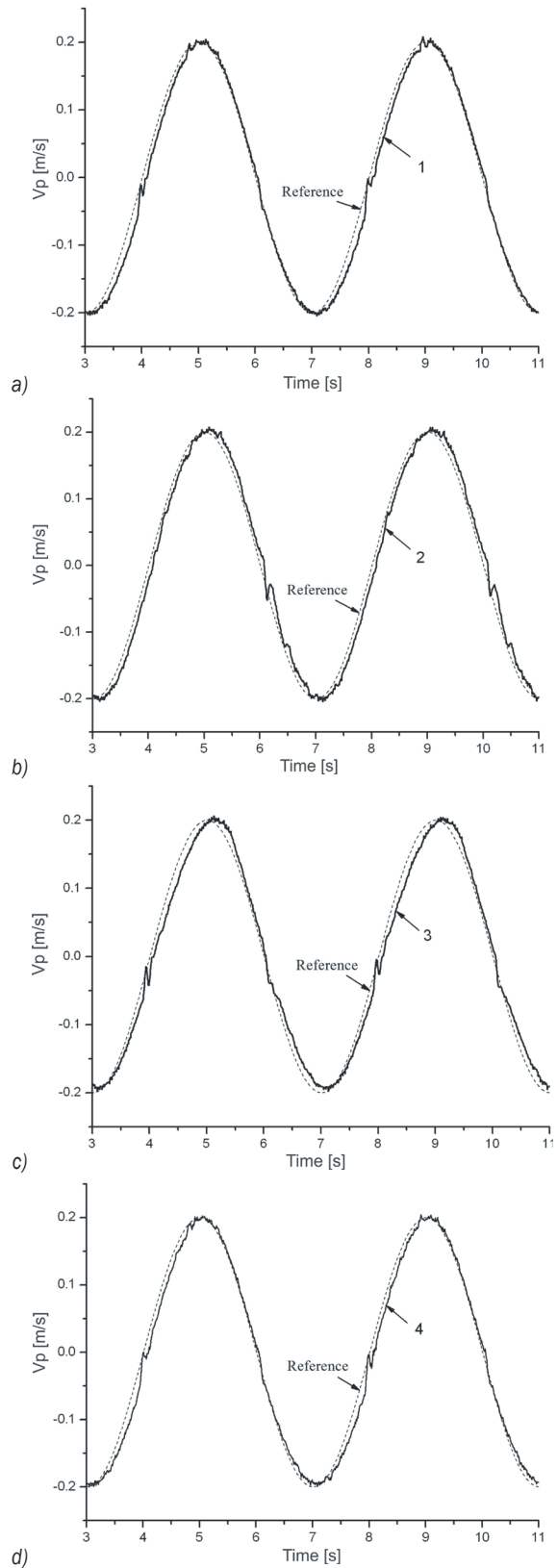

Fig. 15. Velocity experiments on the cylinder using the four drive principles on the sine reference signal; a) to d)

Fig. 16 shows the spectra of hydraulic power consumption of the cylinder using the four different drive principles on the sine reference signal. The frequency of the sine reference signal ranges from 0.25 to 3 Hz. As shown in Fig. 16, the hydraulic power consumption in System 1 is always the largest. System 2 has the smallest hydraulic power consumption. System 4 consumes a little more hydraulic power than System 3 because the electric motor has little time to slow down at high frequency bandwidths.

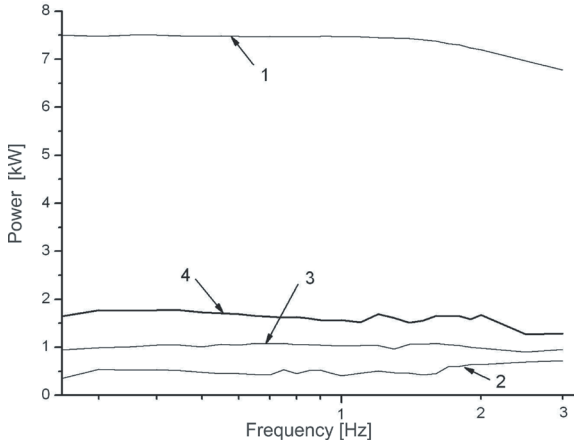

Fig. 16. Spectra of hydraulic power experiments of the cylinder using the four different drive principles on the sine reference signal

According to Figs. 15 and 16, it can be seen that the energy regulation drive not only speeds up the response when the cylinder needs to accelerate but also contributes to better speed tracking and improved energy-saving performance.

5 CONCLUSIONS

The energy regulation based variable-speed electrohydraulic drive is a good method of improving the response and low-speed performance of the variable-speed drive. However, it is a MIMO control system, coupled with strong nonlinear and structural uncertainties, which make the control strategy complex. A compound PID control strategy, as well as a parameter tuning rule, is proposed to address these issues.

The proposed novel drive principle will increase the cost of the system and increase control complexity. However, the simulation and experimental results show that it demonstrates a good comprehensive performance with high speed-control accuracy, a fast response, and a good energy-saving performance, all of which are useful in practical applications.

6 ACKNOWLEDGEMENT

This research is supported by the National Natural Science Foundation of China (Grant No. 51205099), the Zhejiang province key science and technology innovation team (Grant No. 2010R50003), and the Zhejiang Open Foundation of Most Important Subjects.

7 NOMENCLATURE

- e_d integral separation threshold of directional valve control [m/s]
- e_f integral separation threshold of frequency converter control [m/s]
- e_e integral separation threshold of ERD control [m/s]
- f_{in} input frequency of frequency converter [Hz]
- f_{imax} maximum input frequency of frequency converter [Hz]
- f_{imin} minimum input frequency of frequency converter [Hz]
- f_{min} minimum work-frequency [Hz]
- K_{in} feedforward parameter of frequency converter control
- k_{fp}, k_{fi}, k_{fd} PID control parameters of frequency converter
- k_{ip}, k_{iv}, k_{id} PID control parameters of ERD
- k_{dp}, k_{di}, k_{dd} PID control parameters of proportional directional valve
- λ_d integral separation parameter of proportional directional valve control
- λ_f integral separation parameter of frequency converter control
- λ_e integral separation parameter of ERD control
- l stroke of the cylinder rod [m]
- p_e pressure of energy regulation device [Pa]
- p_s pressure of hydraulic pump outlet [Pa]
- P_s hydraulic power consumption [kW]
- Q_s flow of hydraulic pump outlet [m³/s]
- u_d control voltage of proportional directional valve [V]
- u_t control voltage of proportional flow valve in ERD [V]
- v_A maximum velocity of cylinder rod [m/s]
- v_{in} reference velocity of cylinder rod [m/s]
- v_p actual velocity of cylinder rod [m/s]
- v_{m0} preset minimum speed of cylinder [m/s]
- w frequency [Hz]
- x_p position of cylinder rod [m]

8 REFERENCE

- [1] Ristic, M. (2008). Conversant technology – New key aspects: Development of variable speed drives. *Proceedings of International Fluid Power Conference*, Dresden, p. 93-108.
- [2] Yutaka, T., Kazuo, N. [1991]. Variable-speed control of hydraulic pump for energy-savings. *International Symposium on Fluid Power Transmission and Control*, Beijing, p. 10-14.
- [3] Manasek, R. (2000). Simulation of an electro-hydraulic load-sensing system with AC motor and frequency changer. *Proceeding of the 1st FPNI-PhD Symposium*, Hamburg, p. 311-324.
- [4] Helduser, S. (2003). Improved energy efficiency in plastic injection molding machines. *The 8th Scandinavian International Conference on Fluid Power*, Tampere, Finland, p. 1219-1229.
- [5] Jelali, M., Kroll, A. (2003). *Hydraulic Servo-system: Modeling, Identification and Control*. Springer, DOI:10.1007/978-1-4471-0099-7.
- [6] Berubger, A.G. (1998). The frequency-controlled hydraulic drive. *Elevator World*, vol. 46, no. 2, p. 94-96.
- [7] Biedermann, O., Engelhardt, J., Geerling, G. (1998). More efficient fluid power systems using variable displacement hydraulic motors. *The 21st International Council of the Aeronautical Sciences Congress*, Melbourne, Australia.
- [8] Dahmann, P. (2002). Closed loop speed and position control of a hydraulic manipulator in brick works with a frequency controlled internal gear pump in motor/pump operation. *The 3rd International Fluid Power Conference*. Aachen.
- [9] Detiček, E., Župerl, U. (2011). An intelligent electro-hydraulic servo drive positioning. *Strojniški vestnik - Journal of Mechanical Engineering*, vol. 57, no. 5, p. 394-404, DOI:10.5545/sv-jme.2010.081.
- [10] Lovrec, D., Kastrevc, M., Ulaga, S. (2009). Electro-hydraulic load sensing with a speed-controlled hydraulic supply system on forming-machines. *International Journal of advanced manufacture technology*, vol. 41, no. 11, p. 1066-1075, DOI:10.1007/s00170-008-1553-y.
- [11] Lovrec, D., Kastrevc, M. (2011) Modeling and simulating a controlled press-brake supply system. *International Journal of Modeling and Simulation*, vol. 10, no. 3, p. 133-144, DOI:10.2507/IJSIMM10(3)3.184.
- [12] Xu, M., Jin, B., Shen, H.K., Li, W. (2010). Analysis and design of energy regulation device in energy regulation based variable speed electro-hydraulic control system. *Chinese Journal of Mechanical Engineering*, vol. 46, no. 4, p. 136-142, DOI:10.3901/JME.2010.04.136.
- [13] Shen, H.K., Jin, B., Chen, Y. (2006). Research on variable-speed electrohydraulic control system based on energy regulating strategy. *ASME International Mechanical Engineering Congress and Exposition*, Chicago.
- [14] Xu M., Jin, B., Yu Y.X., Shen H.K., Li W. (2010). Using artificial neural networks for energy regulation based variable-speed electrohydraulic drive. *Chinese Journal of Mechanical Engineering*, vol. 23, no. 3, p. 327-335, DOI:10.3901/CJME.2010.03.327.