

Surge wave distribution over the power transformer continuous disc winding

Mislav Trbušić¹, Marko Čepin²

¹Kolektor Etra, Šlandrova ul. 10, 1000 Ljubljana, Slovenija

²Fakulteta za elektrotehniko, Univerza v Ljubljani, Tržaška 25, 1000 Ljubljana, Slovenija
E-mail: mislav.trbusic@etra33.si

Abstract. The paper presents a method enabling calculation of the radial and serial capacitance, inductance and voltage between adjacent coils of the power transformer continuous disc winding. Definition of the equivalent electric circuit is based on the assumption of a short circuit and grounded winding next to the iron core. This way all radial capacitances are at the same time also ground capacitances. Calculation of the serial capacitance is based on the assumption of linear voltage distribution along the coil. The inductance is obtained from the stray magnetic field in the transformer window calculated in the FEMM 4.2 computer code. The equivalent circuit with respect to the 1st and 2nd Kirchhoff's law gives two systems of ordinary differential equations for the voltage and current that are solved using MATLAB calculation. Results are compared with measurement results obtained on a dry type transformer TBS (22/6.3 kV, 800 kVA, $u_k = 5.5\%$). A comparison shows that differences between the calculated and measured values are acceptable.

Keywords: Transformer, continuous disc winding, surge wave, capacitance, inductance

1 PREFACE

Overvoltages occurring in the power transformer windings, are caused by lightning or switching overvoltages. The distribution of voltages along the windings is heavily affected by the forehead and back shape of the high voltage pulses. As these events are inevitable during the transformer operation, winding insulation must be carefully planned to withstand them.

The IEC 60076 standard specifies shapes and levels of insulation at which the transformer is tested [6]. The surge wave that simulates the atmospheric discharge takes the form of 1.2/50 and it is the standard test that every power transformer must pass.

Interleaved and continuous disc type of the coil is commonly used for the power transformer high voltage windings. Due to technological and time reasons, the use of interleaved windings is usually avoided. On the other hand, the interleaved winding has 3-6 times lower initial voltage distribution than the continuous disc winding, which is vital for voltage fluctuations in the winding.

Because of the large volume of work and congestion of winding machines in the production cycle, the need for continuous disc winding is growing. In order to adapt to new requirements, it is essential to know the voltage conditions inside the winding during the surge wave test as this is the basis for assessing the winding suitability.

The paper presents a method enabling calculation of the capacitance, inductance and voltage distribution over the transformer continuous disc winding. By comparing the obtained measurements and results, the applicability of the method in everyday engineering practice is proven.

2 SURGE WAVE CALCULATION

Surge wave distribution over the continuous disc winding of power transformer is calculated based on the equivalent electric circuit, which is represented by lump parameters L , C , K (Figure 1). Mutual inductances M are also included, but are not plotted for better clarity. The equivalent circuit elements are made of two coils, so the voltage along each element represents the voltage in the gap between the adjacent coils. The winding end is grounded.

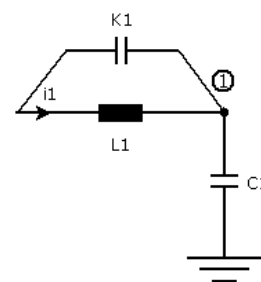

Figure 1. Lumped parameter model of the transformer continuous disc winding.

2.1 Capacitance calculation

To determine the capacitance, the winding can be represented as a capacitive circuit that includes both the shunt and serial capacitance. Figure 2 shows a winding made of six coils and associated capacitive circuit.

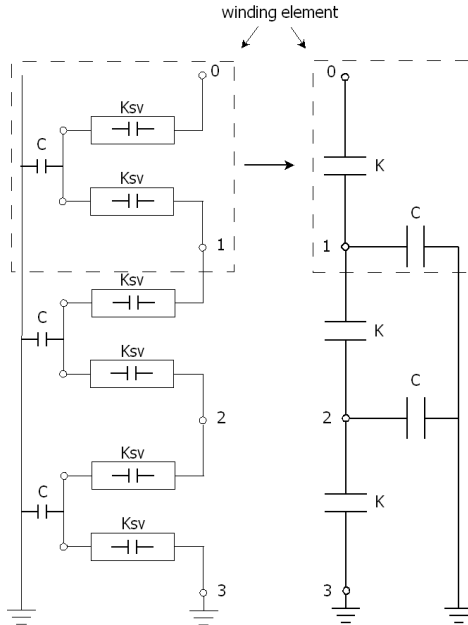

Figure 2. Equivalent capacitive circuit of the transformer continuous disc winding.

Letters *C* and *K* mark the shunt and serial capacitance of the winding element, respectively. The relationship between the serial capacitance of coil *K_{sv}* and the serial capacitance of equivalent element *K* is defined by equation (1) [1].

$$K = \frac{K_{sv}}{2} \tag{1}$$

2.1.1 Serial capacitance calculation

The serial capacitance refers to the capacitance between the turns and adjacent coils of the test winding. With a sufficiently good approximation the coil serial capacitance can be obtained by term (2) [1], [2].

$$K_{sv} = \frac{4}{3} \cdot C_d + \frac{C_{ov}}{m-1} \tag{2}$$

The end coil serial capacitance with no potential ring can be calculated from equation (3) [1].

$$K_{sv} = \frac{2}{3} \cdot C_d + \frac{C_{ov}}{m-1} \tag{3}$$

m ...number of turns in the coil

C_d is the capacitance in the radial gap between adjacent coils (Figure 3) calculated using equation (4) [3].

$$C_d = 27,8 \cdot d_i \cdot \left[\frac{a_{ti} + 2 \cdot (h_k + pap)}{\frac{pap}{\epsilon_{pap}} + \frac{h_k}{\epsilon_{TB-Oil}}} \right] \cdot 10^{-15} \text{ [F]} \tag{4}$$

- h_k* ... height of the radial gap [mm]
- a_{ti}* ...width of winding [mm]
- pap* ...double side thickness of paper insulation [mm]
- d_i* ...mean diameter of the winding [mm]
- β'* ...spacing coverage factor of the winding
- ε_{pap}* ...relative dielectric constant of paper insulation
- ε_{TB-Oil}* ...relative dielectric constant for radial gap between the adjacent coils

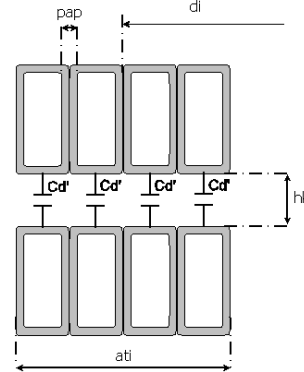

Figure 3. Capacitance in the radial gap between the adjacent coils

C'_d is the capacitance in the radial gap between the adjacent turns of the adjacent coils (5).

$$C'_d = \frac{C_d}{m} \tag{5}$$

The capacitance between the adjacent turns (Figure 4) is determined by equation (6) [3].

$$C_{ov} = 27,8 \cdot \epsilon_{pap} \cdot d_i \cdot \left[\frac{b_0 + 2 \cdot pap}{pap} \right] \cdot 10^{-15} \text{ [F]} \tag{6}$$

b_0 ...height of the bare wire or transpose cable [mm]
 d_i ...mean diameter of the winding [mm]
 pap ...double side thickness of paper insulation [mm]
 ϵ_{pap} ...relative dielectric constant of paper insulation

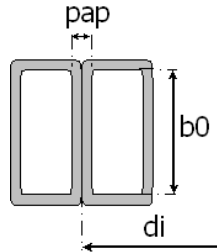

Figure 4. Capacitance between the turns.

2.1.2 Shunt capacitance calculation

The shunt capacitances are capacitances of the test winding at the adjacent windings and grounded parts of the transformer (yoke, tank). During the test, all the adjacent windings are short-circuited and grounded, thus all shunt capacitance become ground capacitance. The capacitance is determined depending on the position of the test winding. Figure 5 shows the earth capacitance of the middle phase of the transformer.

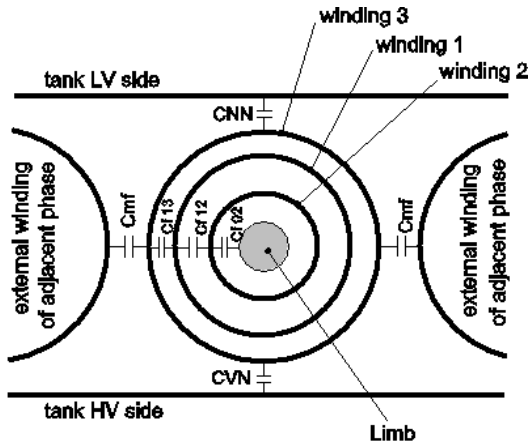

Figure 5. Shunt (ground) capacitances for the middle phase of the three phase transformer.

Among the windings of the same phase (Figure 6) there are capacitances C_f , which are calculated by equation (7) [3].

$$C_f = \frac{27,8 \cdot d_{sr} \cdot (b_g + 2 \cdot d)}{d - fak \cdot deb} \cdot 10^{-15} \text{ [F]} \quad (7)$$

d_{sr} ...mean diameter of the gap between the windings [mm]
 b_g ...height of the shorter winding [mm]
 d ...double width of the gap between windings [mm]
 deb ...thickness of solid insulation between the the windings [mm]

ϵ_{TB} ...relative dielectric constant of solid insulation between the windings
 ϵ_{Oil} ...relative dielectric constant of oil
 $fak \dots (\epsilon_{TB} \cdot \epsilon_{Oil}) / \epsilon_{TB}$

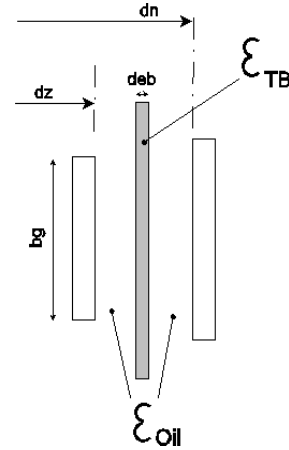

Figure 6. Capacitance between the two windings of the same phase.

Equation (8) [3] holds for the capacitance between the outer windings of the adjacent phases (Figure 7).

$$C_{mf} = \frac{27,8 \cdot b_g}{\ln \left(\frac{x_n}{R_s} + \sqrt{\left(\frac{x_n}{R_s} \right)^2 - 1} \right)} \cdot \kappa \cdot 10^{-15} \text{ [F]} \quad (8)$$

$$\kappa = \frac{x_n - R_s}{\frac{x_n - R_s - deb}{\epsilon_{Oil}} + \frac{deb}{\epsilon_{TB}}}$$

x_n ... half the distance between the limb center [mm]
 R_s ...outer diameter of the most outer winding [mm]
 Other marks have the same meaning as above.

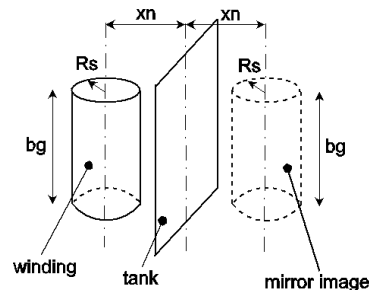

Figure 7 : Geometry used in determination of the shunt capacitances between the most outer windings of the adjacent phases and between the most outer winding and the tank.

Equation (8) can be used to determine the capacitance between the external winding and tank (C_{NN} , C_{VN}). Instead of half the distance between the limb center x_n , the minimum distance between the axe of the external winding and the tank is inserted, and the entire expression multiplied by 2 (9)[3].

$$C_k = 2 \cdot C_{mf} \tag{9}$$

The total ground capacitance of winding C_g is the sum of all partial ground capacitances appearing in a particular case.

Capacitance C of the equivalent winding circuit is determined by dividing the total ground capacitance by the number of elements in the equivalent winding circuit (10).

$$C = \frac{C_g}{N_{el}}, \tag{10}$$

N_{el} ... number of elements in the equivalent electric circuit

2.2 Inductance calculation

Inductances in the equivalent electric circuit are determined based on the assumption (of a short circuit winding next to the iron core). This assumption allows us to neglect the influence of the iron core in the inductance system [1].

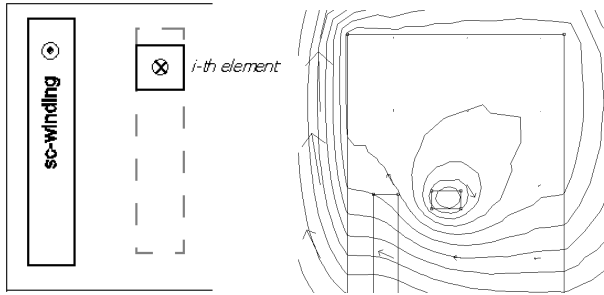

Figure 8. Elements layout and calculation $L_{\sigma-KS}$ using the computer program FEMM 4.2.

Due to a good magnetic coupling between the windings and coils, self and mutual inductances can be determined from the stray magnetic field in the transformer window (11) [1].

Figures 8 and 9 show a layout of the elements and directions of the currents in the inductance calculation using the FEMM 4.2 computer program [4].

$$L_{\sigma} = \frac{2 \cdot W_{mag}}{I^2} \quad (I = I \text{ A, DC}) \tag{11}$$

W_{mag} ...magnetostatic energy in the transformer window

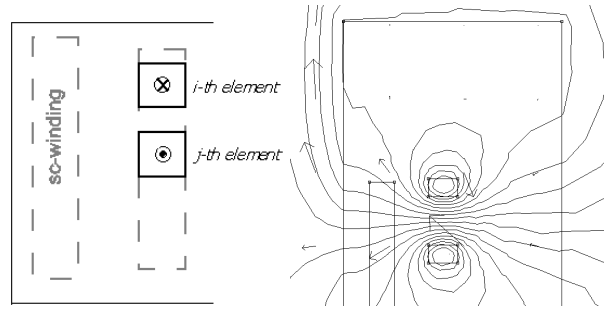

Figure 9. Elements layout and calculation $L_{\sigma-j}$ using the FEMM 4.2 computer program.

Self inductance of the winding element is calculated by multiplying the leakage inductance between the element and the short-circuit winding reduced to one turn and multiplied by the square of the number of turns in the element (12) [1].

$$L_i = w_i^2 \cdot L_{\sigma-KS} \tag{12}$$

Mutual inductance between the elements is determined by equation (13) [1].

$$M_{i-j} = \frac{L_{\sigma-KS} + L_{\sigma-KS} - L_{\sigma-j}}{2} \cdot w_i \cdot w_j \tag{13}$$

w_i ...number of turns in i-th element

w_j ... number of turns in j-th element

$L_{\sigma-KS}$...leakage inductance between the i-th element and short circuit winding reduced to one turn.

$L_{\sigma-j}$... leakage inductance between the j-th element and short circuit winding reduced to one turn.

$L_{\sigma-i}$... leakage inductance between the i-th and j-th element of the winding reduced to one turn.

2.3 Equations

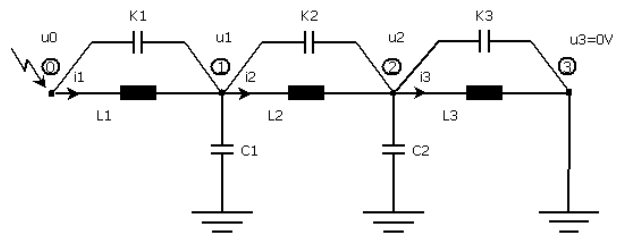

Figure 10. Equivalent electric circuit of the winding build up of three elements.

Figure 10 shows the equivalent electric circuit of the winding. First Kirchoff's Law holds with respect to the currents in the nodes.

$$\begin{aligned} i_1 - i_2 + K_1 \cdot \frac{d}{dt}(u_0 - u_1) - K_2 \cdot \frac{d}{dt}(u_1 - u_2) - C_1 \cdot \frac{du_1}{dt} &= 0 \\ i_2 - i_3 + K_2 \cdot \frac{d}{dt}(u_1 - u_2) - K_3 \cdot \frac{d}{dt}(u_2 - u_3) - C_2 \cdot \frac{du_2}{dt} &= 0 \end{aligned}$$

Rearrangement and translation to the matrix notation gives the following equation.

$$\frac{d}{dt} \begin{bmatrix} u_1 \\ u_2 \end{bmatrix} = \begin{bmatrix} K_1 + K_2 + C_1 & -K_2 \\ -K_2 & K_2 + K_3 + C_2 \end{bmatrix}^{-1} \cdot \begin{bmatrix} 1 & -1 & 0 \\ 0 & 1 & -1 \end{bmatrix} \cdot \begin{bmatrix} i_1 \\ i_2 \\ i_3 \end{bmatrix} +$$

$$\begin{bmatrix} K_1 + K_2 + C_1 & -K_2 \\ -K_2 & K_2 + K_3 + C_2 \end{bmatrix}^{-1} \cdot \begin{bmatrix} K_1 \\ 0 \end{bmatrix} \cdot \frac{du_0}{dt}$$

Or in a shorter form:

$$\frac{d}{dt} [u] = [CK]^{-1} \cdot [D] \cdot [i] + [CK]^{-1} \cdot [EK] \cdot \frac{du_0}{dt} \quad (14)$$

The second Kirchoff's Law holds for the voltages along the closed loops.

$$\begin{aligned} u_0 - u_1 &= L_1 \cdot \frac{di_1}{dt} + M_{1-2} \cdot \frac{di_2}{dt} + M_{1-3} \cdot \frac{di_3}{dt} \\ u_1 - u_2 &= M_{1-2} \cdot \frac{di_1}{dt} + L_2 \cdot \frac{di_2}{dt} + M_{2-3} \cdot \frac{di_3}{dt} \\ u_2 &= M_{1-3} \cdot \frac{di_1}{dt} + M_{2-3} \cdot \frac{di_2}{dt} + L_3 \cdot \frac{di_3}{dt} \end{aligned}$$

In the matrix notation:

$$\frac{d}{dt} \begin{bmatrix} i_1 \\ i_2 \\ i_3 \end{bmatrix} = \begin{bmatrix} L_1 & M_{1-2} & M_{1-3} \\ M_{1-2} & L_2 & M_{2-3} \\ M_{1-3} & M_{2-3} & L_3 \end{bmatrix}^{-1} \cdot \underbrace{\begin{bmatrix} -1 & 0 \\ 1 & -1 \\ 0 & 1 \end{bmatrix}}_{-[D]^T} \cdot \begin{bmatrix} u_1 \\ u_2 \end{bmatrix} +$$

$$\begin{bmatrix} L_1 & M_{1-2} & M_{1-3} \\ M_{1-2} & L_2 & M_{2-3} \\ M_{1-3} & M_{2-3} & L_3 \end{bmatrix}^{-1} \cdot \begin{bmatrix} 1 \\ 0 \end{bmatrix} \cdot u_0$$

In a shorter form:

$$\frac{d}{dt} [i] = -[L]^{-1} \cdot [D]^T \cdot [u] + [L]^{-1} \cdot [F] \cdot u_0 \quad (15)$$

Putting terms (14) and (15) together gives us a linear system of ordinary differential equations (16) solved by MATLAB.

$$\begin{bmatrix} \frac{di}{dt} \\ \frac{du}{dt} \end{bmatrix} = \begin{bmatrix} 0 & \alpha \\ \beta & 0 \end{bmatrix} \cdot \begin{bmatrix} i \\ u \end{bmatrix} + \begin{bmatrix} \gamma \cdot u_0 \\ \delta \cdot \frac{du_0}{dt} \end{bmatrix} \quad (16)$$

$$\alpha = -[L]^{-1} \cdot [D]^T$$

$$\beta = [CK]^{-1} \cdot [D]$$

$$\gamma = [L]^{-1} \cdot [F]$$

$$\delta = [CK]^{-1} \cdot [EK]$$

$[u_0]$...surge wave

$[u]$...vector with unknown nodal potentials

$[i]$...vector with unknown branch currents

$[CK]$...matrix with capacitances

$[EK]$...vector with capacitive connections between surge wave u_0 and other nodes

$[D]$...first difference matrix

$[L]$...matrix with inductances

$[F]$...vector with direct connections between surge wave u_0 and other nodes

3 RESULTS

Results of our calculation of the surge wave in the power transformer winding are gradients between the adjacent coils in the winding and are determined by equation (17). They are compared with measurements obtained on a dry type transformer TBS (22/6.3 kV, 800 kVA, uk=5.5%) found in reference [1].

$$\Delta u_{i+1} = \max(|u_i - u_{i+1}|) \quad i=0,1,2\dots N_{el} \quad (17)$$

u_i ...potential of the i-th node in the equivalent electrical circuit

N_{el} ...number of elements of the winding

The surge wave used in our calculation and measurements is 1.2/50 μ s with the peak value 95 kV. The surge wave is described by equation (18).

$$u_0 = 95 \cdot U_0 \cdot (e^{-p_1 t} - e^{-p_2 t}) \quad [kV] \quad (18)$$

$$U_0 = 1.043325$$

$$p_1 = 14732 \text{ s}^{-1}$$

$$p_2 = 2080313 \text{ s}^{-1}$$

Figure 11 shows the calculated and measured values of gradients in the radial gaps between the equivalent circuit elements of the winding, which correspond to the gradient between the adjacent coils. The test voltage is

selected so that the gradients between the coils correspond to the percentage values of the applied surge wave.

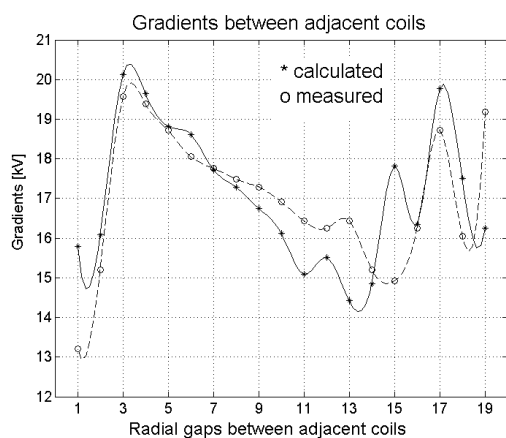

Figure 11. Gradients in the radial gaps between the adjacent coils, calculated (*) and measured values (o).

Figure 12 shows relative deviations of the measured values from the calculated values.

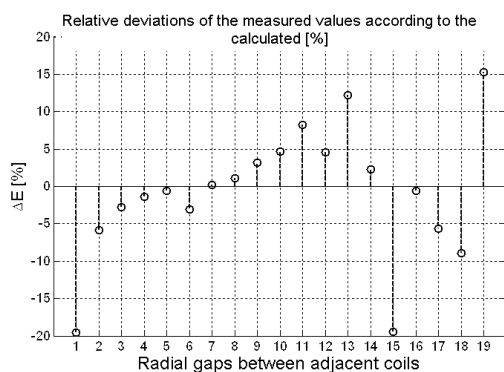

Figure 12. Relative deviations of the measured values from the calculated values.

4 CONCLUSION

The paper presents a method to be used in calculating capacitances, inductances and voltages along the power transformer continuous disc winding. A special computer code was developed to support calculations made according to the presented method. The calculated results were compared with measurement results available in the literature.

As seen from the obtained results, the deviations of the measured and calculated values are within 20%, which is acceptable for the engineering practice [1], [5]. It can be concluded that the calculation of voltage distribution along the power transformer continuous disc winding approximates the actual voltage conditions inside the winding well enough and can therefore be used to design winding insulation.

5 REFERENCES

- [1] B. Čučić: Raspodjela udarnog napona po preloženom namotu transformatora, Magistrsko delo, Fakultet elektrotehnike i računarstva, Zagreb, 2001.
- [2] B. Heller, A. Veverka, Surge Phenomena in Electrical Machines, Publishing House of the Czechoslovak Academy of Sciences, Prague, 1968.
- [3] K. Lenasi, Program ZVRU – koda, Tovarna transformatorjev, Ljubljana, 1991.
- [4] <http://www.femm.info/wiki/HomePage> (last viewed 27.1.2011).
- [5] K. Lenasi, Udarne prenapetosti v navitjih močnostnih transformatorjev z vpeljavo dušenja induktivnih tokov, doktorska disertacija, Ljubljana 1975.
- [6] IEC 60076-1, Power Transformers, Part 1: General, IEC Standard, 2000.
- [7] H. M. Ryan, High Voltage Engineering and Testing, Institution of Electrical Engineers, 2001.

Mislav Trbušić received his B.Sc. degree in electrical engineering from the University of Ljubljana, Slovenia in 2011. He works at Kolektor Etra as a design engineer for power transformers.

Marko Čepin received his B.Sc., M.Sc. and Ph.D. degrees from the University of Ljubljana, Slovenia, in 1992, 1995 and 1999, respectively. In the period from 1992-2009 he was employed with the Jožef Stefan Institute. In 2001, he was invited to Polytechnic University of Valencia. He is president of the Nuclear Society of Slovenia (2010 - 2014). Currently, he is associate professor at the Faculty of Electrical Engineering, University of Ljubljana. His research interests include power engineering, power plants and power system reliability.