

HEURISTIC APPROACH TO CIRCUIT SIZING PROBLEM

Janez Puhan, Árpád Búrmen and Tadej Tuma

University of Ljubljana, Faculty of Electrical Engineering, Ljubljana, Slovenia

Key words: computer aided design, integrated circuits, optimization algorithms, circuit sizing.

Abstract: Circuit sizing problem in application specific analog integrated circuit design is in most cases limited to setting MOSFET channel widths and lengths. It is usually performed by hand by an experienced human designer. As the circuit sizing is an optimization process by its nature, optimization methods could be used. They always lead to one of the minima of the cost function while eventual other minima stay unknown. To reveal different cost minima an optimisation process composed of many individual optimisation runs is proposed. Individual runs are started from various initial points in the parameter space. A particular initial point is determined by a heuristic method which maximises the probability of finding a new cost function minimum in the next run. The optimization process is demonstrated on several real operating amplifier designs.

Heuristični pristop k določevanju elementov v integriranih vezjih

Ključne besede: računalniško podprto načrtovanje, integrirana vezja, optimizacijski algoritmi, določitev elementov.

Izveček: Določitev dimenzij polprevodniških komponent v analognem integriranem vezju se največkrat prevede na določevanje dolžin in širin kanalov MOSFET-ov. To delo navadno opravi izkušen načrtovalec. Ker je celoten proces določevanja dimenzij po svoji naravi optimizacijski postopek, bi lahko v ta namen uporabili optimizacijske metode. Le-te vedno vodijo k enemu izmed minimumov kriterijske funkcije, medtem ko morebitni ostali minimumi ostanejo skriti. V članku predlagamo optimizacijski proces, sestavljen iz več posameznih optimizacijskih tekov, katerih namen je najti več različnih minimumov kriterijske funkcije. Posamezni teki so sproženi iz različnih začetnih točk v parameterskem prostoru. Začetne točke določimo s pomočjo heuristične metode, ki maksimizira verjetnost odkritja novega minimuma v naslednjem teku. Celoten optimizacijski proces je predstavljen tudi na realnih primerih integriranih operacijskih ojačevalnikov.

1 Introduction

Creating a good analogue integrated circuit (or analogue part in a mixed circuit) design is still a hard task, which usually requires senior designer knowledge and skills. There are no predefined libraries of standard cells and networks as in the digital world. Therefore the design of an analogue circuit consisting of a few transistors can be more time consuming than designing a fairly complex digital circuit. Application specific integrated circuit (ASIC) designers also frequently reuse their previous solutions and adapt them to their current needs. A circuit simulator is indispensable in this development procedure. The computers are mainly used to analyze human designs.

Initially a suitable circuit configuration is required, which can potentially fulfil the given requirements. This task is mostly left to the designer although several tools partially automating the topology synthesis appeared in the past /1/-/4/. Then the circuit sizing problem has to be solved. One desires such element sizes (e.g. MOSFET channel widths and lengths, capacitors, resistors, etc.) that required circuit properties are met in the most robust manner. Circuit sizing is an optimization process by its nature and one can find quite an extensive literature in this area. Sizing of nominal circuits was considered in /5/-/6/, sizing problems accounting for parameter tolerances (parameter centering) were addressed in /7/-/9/, and worst-case optimization in /10/-/12/. Various optimization tools were

developed, like equation based GPCAD /13/, which uses geometric programming formulation of an optimization problem /14/ on predefined posynomial equations, AMG /15/, utilising a symbolic simulator /16/ to obtain circuit equations, and the simulation based ASTRX/OBLX /17/. Recently numerous papers (e.g. /12/, /18/-/23/) are addressing the sizing problem from different aspects like process and operating tolerances, mismatch, yield and robustness.

Despite all the research efforts made circuit sizing is still a task that is addressed manually. New sizes for the next experiment are determined by a human designer and not automatically by the optimization method. In our opinion the automated optimization is rarely used because of three major reasons:

- there are no general optimization tools integrated into any of the most popular circuit simulators for ASIC design (optimization tools, e.g. /13/, /15/, /17/, are not integrated into commercial simulators and therefore offer only very limited capabilities),
- the mathematical formulation of the cost function, which would yield acceptable solutions, is rather complicated and demands an experienced user (optimization algorithms can get trapped in senseless regions of parameter space, resulting in degenerated solutions; searching for the minimum of the cost function can also result in circuits highly sensitive to manufacturing process and operating condition variations

/21/; a possible solution is the use of implicit constraints /14/, /20/, /23/), and

- the results of the optimization run are not to be unlim- itedly trusted (in many cases the minimum found is not the global one, even if a global optimization meth- od was used).

This paper focuses on the last of these three drawbacks. There exists many different gradient, quasi gradient, and direct search optimization algorithms. A good survey of the first family can be found in /24/. Gradient based methods are greedy by default and require the derivatives of the cost function to be calculated at each iteration. When ap- plied to circuit sizing, the derivatives are usually calculated by a sensitivity analysis, meaning that the cost function can't be of arbitrary form. Those methods have a strong local nature and are therefore usually used for finetuning cir- cuits /25/.

On the other hand direct search methods /26/-/28/ do not require additional gradient computations. Convergence properties for pattern search methods have been report- ed in /29/. These methods can be classified by their be- haviour as local or global. Some global methods even guar- antee to find the global minimum if certain conditions are fulfilled /30/-/31/.

Performance of an optimization method on cost functions depends on many parameters one of which is the initial point. The same method can lead to quite different results for different initial points. Local methods are more sensi- tive than global ones. The latter have always some ran- domness build into them, which at least partially neutralis- es the importance of the proper selection of the algorithm's initial point.

The selection of the initial point is usually left to the user, who relies upon knowledge and intuition. Usually a point is chosen where the circuit's best performance is expected. If the choice is right, the minimum of the cost function lies near and the optimization task turns to fine tuning of the circuit. But on the other hand no additional information is gained. The optimization process just confirms the expec- tations. A great part of the parameter space is left unex- plored and the question of finding a better solution remains open.

If we want to be assured that no better point exists then the whole parameter space has to be explored. One way to do this is to optimize the circuit starting from several different initial points, and each optimization run has to cover a different part of the parameter space. The optimi- zation process becomes a group of individual optimization runs.

Optimization methods have limited memory and therefore only a few points from previous iterations are used to de- termine the next step. Today computers easily store all the evaluated points, while the evaluation itself is still compu- tationally expensive. Thus the initial point for the next opti-

mization run should be determined using the information obtained from evaluated points. This paper proposes a heuristic method based on the probabilistic approach /32/-/33/. The method puts the new initial point in a part of the parameter space, where the probability of finding a new minimum is high. It can be applied to multidimension- al parameter space and does not require significant com- puter effort.

Several minima are obtained in such an optimization proc- ess. The designer can decide, which one is most appeal- ing and may even continue with the investigation of the unexplored parts of the parameter space. First the mathe- matical background of the assumptions used later in the heuristic algorithm are highlighted. Several optimization cases of CMOS integrated operational amplifiers are illus- trated and the obtained results are commented.

2 Mathematical Background, One Dimensional Probabilistic Approach

Let $E(x)$, $x \in A \subseteq \mathfrak{R}^n$, $E : \mathfrak{R}^n \rightarrow \mathfrak{R}$ denote the cost function where A denotes a feasible region. The purpose of every optimization process is to find a global minimum x_0 of the cost function $E(x)$, $E(x_0) \leq E(x)$, $\forall x \in A$. In one dimension the feasible region of the parameter space is defined as an interval $A = [x_{low}, x_{high}]$. Let us define a continuous sto- chastic process $f(x, \omega)$. It assigns a function $f(x)$ to every outcome $\omega \in \Omega$ of experiment ζ . The domain of ω is the set of all experimental outcomes Ω , and the domain of x is a set of real numbers \mathfrak{R} . Let the one dimensional cost func- tion $E(x)$ be equal to a realisation of the stochastic process $f(x, \omega)$ for an outcome ω_0 on the interval A .

$$E(x) = f(x, \omega_0) \quad \omega_0 \in \Omega \quad x \in A \quad (1)$$

Cost function $E(x)$ is an arbitrary real function on the inter- val A . By its definition the distribution function $G(f_0, x)$ gives the probability of an event $\{f(x, \omega) \leq f_0\}$ at a particular x . We assume normal distribution for $G(f_0, x)$ with variance $\sigma^2(x)$ and expected value $m(x)$.

$$G(f_0, x) = P\{f(x, \omega) \leq f_0\} \\ = \frac{1}{\sqrt{2\pi\sigma(x)}} \int_{-\infty}^{f_0} e^{-\frac{(f-m(x))^2}{2\sigma^2(x)}} df \quad (2)$$

After one or more optimization runs the cost function has been evaluated at several points. Lets say we have k such points x_1, x_2, \dots, x_k , and the corresponding cost function values $E(x_i)$, $i = 1, 2, \dots, k$, are known. An event Z_k is de- fined as $\{f(x_i, \omega) = E(x_i), i = 1, 2, \dots, k\}$. In other words, the event Z_k occurs, when the stochastic process function $f(x, \omega)$ is equal to the cost function $E(x)$ in all known points x_1, x_2, \dots, x_k , for outcome ω . The event Z_k becomes certain if the expected value $m(x)$ is equal to the cost function and if variance $\sigma^2(x)$ is zero at all known points. Therefore $m(x_i) =$

$E(x_i)$ and $\sigma(x_i) \rightarrow 0$ for $i = 1, 2, \dots, k$. When mean and variance have the above properties, the distribution $G(f_0, x)$ becomes the conditional probability of event $\{f(x, \omega) \leq f_0 / Z_k\}$.

Let opt be the index of a point with the lowest cost function value among known points. So the relation $E(x_{opt}) \leq E(x_i)$, $i = 1, 2, \dots, k$, is valid. We define a function $f_{min}(x, \omega)$. Its value is always lower than $E(x_{opt})$ for an arbitrary x and any outcome ω .

$$f_{min}(x, \omega) = \min(E(x_{opt}), f(x, \omega)) \quad (3)$$

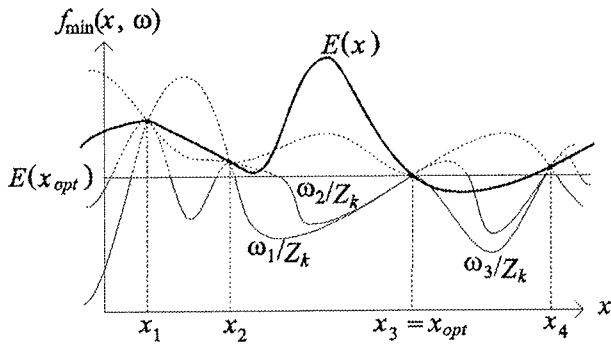

Figure 1: Functions $f_{min}(x, \omega)$ (solid) and realisations of a stochastic process $f(x, \omega)$ (dashed) for different outcomes ω . The event Z_k is certain, therefore $m(x_i) = E(x_i)$ and $\sigma^2(x_i) \rightarrow 0$, $i = 1, 2, \dots, k$, $k = 4$.

Distribution $G_{min}(f_0, x)$ of function $f_{min}(x, \omega)$ gives the probability of event $\{f_{min}(x, \omega) \leq f_0 / Z_k\}$, where Z_k represents a certain event as mentioned above. It can be obtained from the distribution $G(f_0, x)$ and the definition of $f_{min}(x, \omega)$. The probability density function $g_{min}(f_0, x)$ is the derivative of the distribution $G_{min}(f_0, x)$.

$$G_{min}(f_0, x) = P\{f_{min}(x, \omega) \leq f_0\} \\ = G(f_0, x) + (1 - G(f_0, x))u(f_0 - E(x_{opt})) \quad (4)$$

$$g_{min}(f_0, x) = \frac{\partial G_{min}(f_0, x)}{\partial f_0} = \\ = \frac{e^{-(f_0 - m(x))^2 / 2\sigma^2(x)}}{\sqrt{2\pi\sigma(x)}} (1 - u(f_0 - E(x_{opt}))) + \\ (1 - G(E(x_{opt}), x))\delta(f_0 - E(x_{opt})) \quad (5)$$

Functions $u(f_0 - E(x_{opt}))$ and $\delta(f_0 - E(x_{opt}))$ in (4) and (5) represent a unit step function and its derivative, a unit Dirac impulse, respectively.

The expected value $E\{f_{min}(x, \omega) / Z_k\}$ is the mean of the function $f_{min}(x, \omega)$ at a particular x . Because of event Z_k it is equal to the cost function's value $E(x_{opt})$ in all k known

points. The question is where to choose the new initial point for the next optimization run, if the cost function is already known in k points. A natural decision is to set it where the expected value $E\{f_{min}(x, \omega) / Z_k\}$ is minimal. To find out a new starting point x_0 a minimisation problem (6) has to be solved. The integral definition of the expected value expresses the minimisation problem with the density function $g_{min}(f_0, x)$. The upper bound of the integral can be set to $E(x_{opt})$ using equation (5).

$$x_0 = \min_{x \in A} (E\{f_{min}(x, \omega) / Z_k\}) \\ = \min_{x \in A} \left(\int_{-\infty}^{\infty} f_0 g_{min}(f_0, x) df_0 \right) \\ = \min_{x \in A} \left(\int_{-\infty}^{E_{opt}} f_0 g_{min}(f_0, x) df_0 \right) \quad (6)$$

The minimisation problem (6) can be transformed into a maximisation problem (7) using the distribution function $G_{min}(f_0, x)$ instead of the probability density.

$$x_0 = \max_{x \in A} \left(\int_{-\infty}^{E_{opt}} G_{min}(f_0, x) df_0 \right) \\ = \max_{x \in A} \left(\frac{\sigma(x)}{\sqrt{2\pi}} \int_{-\infty}^{E(x_{opt}) - m(x) / \sigma(x)} \int_{-\infty}^u e^{-t^2 / 2} dt du \right) \quad (7)$$

The probability distribution and the density function of a limited random walk, also known as Wiener process $w(t)$, are normal with constant mean and variance increasing with t . We also assume normal distribution for our process $f(x, \omega)$. Wiener process $w(t)$ is a continuous function of variable t . Suppose the cost function $E(x)$ is continuous in the vicinity of known points, so it can be a sample path of a Wiener process there. This assumption does not place any physically unrealistic limitations on types of cost functions, which take place in circuit design optimization problems. Therefore we can presume a constant expected value and a linearly increasing variance near known points. We set the mean and variance to $m(x) = E(x_i)$ and $\sigma^2(x) = \alpha |x - x_i|$ around i^{th} point. Then event Z_k is certain as well. In the neighbourhood of every determined point equation (7) becomes

$$x_0 = \max_{x \in A} \left(\sqrt{\frac{\alpha |x - x_i|}{2\pi}} \int_{-\infty}^{E(x_{opt}) - E(x_i) / \sqrt{\alpha |x - x_i|}} \int_{-\infty}^u e^{-t^2 / 2} dt du \right) \quad (8)$$

$i = 1, 2, \dots, k$.

The expression in equation (8) is a monotonically decreasing function of cost value $E(x_i)$ and monotonically increasing function of distance $|x - x_i|$. This leads to two conclusions:

- first due to decrease with $E(x_i)$ the new initial point x_0 lies rather closer to the known points with lower cost function value, than to those with higher cost function value,
- due to the increase resulting from $|x - x_i|$ it lies away from all known points so the distance to the nearest one is as large as possible.

Both conclusions can be intuitively generalized to n dimensional parameter space. A simple heuristic method described in the following section is based on this generalisation.

3 A Heuristic Method for Finding New Initial Points

The second conclusion tells us, that a new initial point has to be somewhere in the parameter space, where the density of already evaluated points is low. If it is low, then we expect the average distance between two nearest points to be large in general. But we have to define how to measure the density of known points. Let us divide the parameter space into 2^n equal subspaces (2^n equal boxes). Let the density be equal to the number of known points in a particular subspace, and let it be constant across the whole subspace. A new initial point will be chosen in the subspace with the lowest density.

The first conclusion on the other hand tells us, that the contribution to the density is not always the same for all already evaluated points. Those with lower cost function values should contribute less, than the ones with higher cost function values. In the previous definition all of them contributed one unit, regardless of the cost function value. Therefore known points have to be weighted. Each point will contribute its weight, which has to be proportional to its cost. Let the weight u of a point with cost function value E be defined by equation (9).

$$u = \frac{(\beta - 1)E + E_{max} - \beta E_{min}}{E_{max} - E_{min}} \quad (9)$$

E_{min} and E_{max} represent the lowest and the highest cost function value among already determined points, respectively. The point with the lowest cost function value has always weight one. The weight of the point with the highest cost function value is given by coefficient β , and now it contributes β times more to the density, than the lowest point.

So far all known points, for which we know, that they violate implicit constraints, are still not included in our definition of density. They lack a cost function value E , so their weight can not be calculated by equation (9). But those points give us some information about the cost function and therefore they have to be taken into account. We set their weight to 2β .

Finally the heuristic algorithm for determining a new initial point for the next optimization run is described in the re-

peat until loop (Fig. 2) below. The space is divided into 2^n equal subspaces, until we find a subspace with no points determined yet. A new initial point is selected there randomly. The algorithm is very simple, so it demands only a small amount of computational time.

```

calculate weights for all known points;
temporary space := explicitly constrained space;
repeat
  divide temporary space into  $2^n$  equal subspaces;
  add up weights in particular subspaces;
  temporary space :=
    subspace with the lowest sum of weights;
until lowest sum  $\neq 0$ 
randomly pick new point in temporary space;
    
```

Figure 2: Symbolic algorithm of heuristic initial point determination for a new optimization run.

4 Sizing Problem Cases and Results

In this section three CMOS design cases are described to illustrate the capabilities of the proposed approach. Two simple two-stage operational amplifiers with p and n -channel differential pair (Figs. 3 and 4) and a telescopic cascode operational amplifier (Fig. 5) were optimized. Several versions of the above three sample circuits optimized to meet different requirements were used as a part of larger mixed signal integrated circuits. The amplifiers were designed for and produced in $0.3\mu\text{m}$ and $0.8\mu\text{m}$ technology. The parameters varied were all transistor channel dimensions (widths and lengths), MOS multiplier factors and also the resistances and the capacitances.

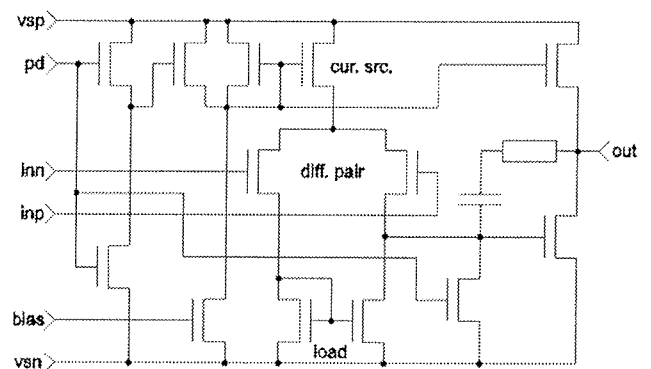

Figure 3: Operational amplifier with p -channel differential pair.

The circuit characteristics that take part in the cost function are listed in the upper part of Tables 1 and 2. The cost function is a rather complicated mathematical formulation which combines results of several types of analyses in several different operating conditions (variable supply and reference voltages, variable bias current, variable temperature etc.) and manufacturing environments (variable production process conditions given with corner transistor models) / 12/. Beside searching for an optimal nominal circuit the robustness is also taken into account. For the

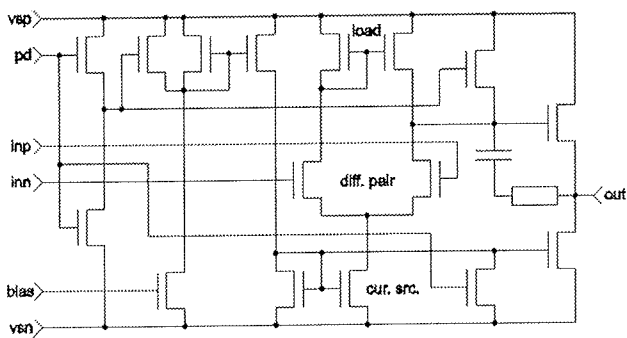

Figure 4: Operational amplifier with n-channel differential pair.

two-stage amplifiers mismatching is simulated by slight model variations of one of the matching transistors. The shape of such a complicated cost functions in multidimensional parameter space is completely unknown. Finding a global minimum is a difficult task for any optimization method and circuit simulator since it requires many circuit anal-

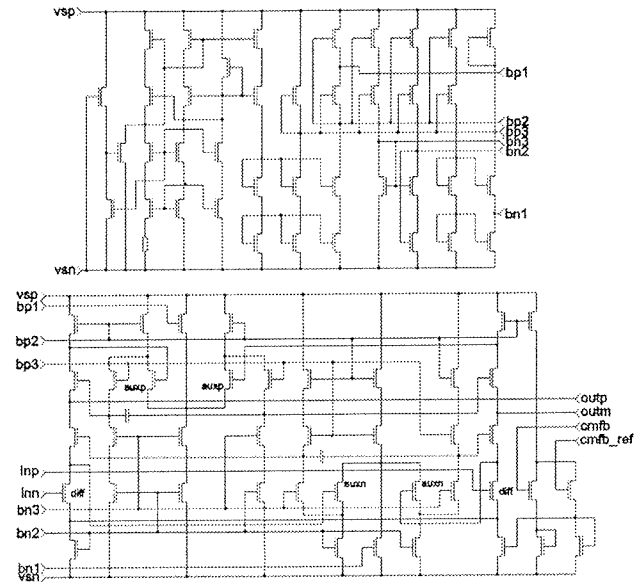

Figure 5: Telescopic cascode operational amplifier.

property		target	p-channel diff. pair				n-channel diff. pair			
A	μm^2	↓	11619	12289	12241	10105	14151	13521	17706	14286
v_{pp}	V	↑	3.7	3.7	3.8	3.6	3.8	3.9	3.8	3.8
v_{pp}/v_{inpp}		↑	2101	2937	2153	2159	4535	4246	4232	4741
v_{offset}	μV	↓	87	60	96	49	32	81	49	11
$v_{outoffset}$	mV	↓	201	199	198	199	99	101	100	100
i_p	μA	↓	727	636	674	559	689	828	754	659
f_{0dB}	MHz	↑	20	20	20	14	16	20	14	13
pm	°	↑	37	37	31	23	34	40	55	37
am	dB	↓	-39	-37	-24	-22	-40	-32	-38	-40
$CMRR$	dB	↓	-96	-100	-91	-97	-108	-106	-104	-102
$PSRR_p$	dB	↓	-89	-90	-112	-101	-49	-50	-46	-48
$PSRR_n$	dB	↓	-62	-62	-60	-58	-50	-51	-51	-52
$noise_{1/f}$	$\text{nV}/\text{Hz}^{1/2}$	↓	100	91	80	56	114	100	102	108
$noise_{term}$	$\text{nV}/\text{Hz}^{1/2}$	↓	9.0	9.5	9.0	10.3	8.6	9.4	9.0	8.6
t_{rise}	ns	↓	361	431	405	431	285	259	243	312
t_{fall}	ns	↓	174	134	171	216	479	426	440	582
transistor			mw/l ratio							
differential pair			173	141	200	151	130	117	41	154
active load			12	9	12	4	18	21	41	14
current source			18	24	18	7	19	10	31	39

Notations: A ... area, v_{pp} ... peak-to-peak voltage, v_{pp}/v_{inpp} ... dc gain, v_{offset} ... offset voltage, $v_{outoffset}$... symmetry, i_p ... current consumption, f_{0dB} ... frequency at 0dB gain, pm ... phase margin, am ... amplitude margin, $CMRR$... common mode rejection ratio, $PSRR_p$... power supply rejection ratio to positive terminal, $PSRR_n$... power supply rejection ratio to negative terminal, $noise_{1/f}$... noise at low frequencies (at 100Hz), $noise_{term}$... thermal noise at higher frequencies (at 100kHz), t_{rise} ... rise time, t_{fall} ... fall time, m transistor multiplier, w channel width and l channel length. Symbols ↑ and ↓ indicate that the desired value is as high or as low as possible.

Table 1: Results of some successful optimization runs for both two-stage amplifiers (0.8 μm technology)

yses. Nevertheless we expect that somewhere in the parameter space there is a global minimum which defines the optimal solution satisfying the given requirements.

The results for the two-stage operational amplifiers are summarised in Table 1 and for the telescopic cascode operational amplifier in Table 2. Only some of the optima found with the initial point set by the described heuristics are given because of the tables size. The upper part of both Tables contains nominal circuit performances. The lower part summarises parameter values in each minimum. Multiplying factor * channel width / channel length ($mw = l$) ratio is given for some transistors in all three cases. If short channel effects in submicron region are neglected then the ratio defines a transistor. Therefore it is convenient for estimating if two solutions are equivalent.

The optimization method used in a particular run is not essential. In fact any local method can be used since global methods tend to the global minimum regardless of the chosen initial point. Direct methods are preferable since the derivatives of the cost function are not required (often impossible to calculate without resorting to perturbation methods which are not accurate enough). So one can use any simplex, quasi gradient (metric matrix, trust region etc.), heuristic, etc. based method. In our experiments a heuristic simplex based method was used. The cost function was composed as a weighted sum of deviations from the target values for nominal and worst conditions. If a particular target is fulfilled the optimization process does not tend to improve it any further. Approximately 500 to 1000 circuit evaluations were needed for one run to converge and on the average every third run was successful. Thus the results in Table 2 were obtained in 30000 circuit evaluations. Comparing this result to a performance of well known global optimization methods like simulated annealing or genetic algorithms is encouraging since over 150000 circuit

evaluations are needed to optimize a circuit like the telescopic cascode amplifier.

From all presented cases we can see that many different solutions of the circuit sizing problem exist. An interesting parallel can be drawn with /34/-/35/ where the entire circuit synthesis problem (topology and sizing) was addressed by genetic programming. Uncommon circuit topology solutions were found beside well known ones.

More or less the same circuit properties can be obtained with several different sets of circuit parameters. Two explanations are at hand: 1.) the target values are too loose for the used circuit configuration and for the given technology and are easily fulfilled, or 2.) the optimization run is stopped at different trade offs among given targets. Because all requirements are never fulfilled the second explanation is more probable. To confirm this, the same experiments were repeated with tighter targets. The requirements remained unfulfilled and individual solutions didn't merge.

A closer look at the Table 2 also confirms that the solutions represent trade offs among required targets. We can see for instance that the last two results have complementary properties. While the solution from column nine has low v_{pp} , pm and am it has high i_p and f_{0dB} . On the other hand the last circuit (column 10) has opposite properties. The same observations can be made in Table 1.

5 Conclusion

A simple heuristic method for setting the initial points of individual optimization runs was described. The idea is based on a one dimensional probabilistic approach extended to multidimensional parameter space. The main objective is to uniformly search the parameter space with a sequence of optimization runs. Each run contributes some

property		target	telescopic cascode operational amplifier									
A	μm^2	↓	2795	2605	2688	2603	2735	2706	3000	2686	2905	2479
v_{pp}	V	↑	3.0	2.7	2.9	2.8	2.8	2.9	2.8	2.8	2.3	3.1
v_{pp}/v_{inpp}		↑	133	139	135	135	137	134	135	135	136	135
$cmfb_{offset}$	μV	↓	24	0.4	34	1	38	5	21	0.3	25	30
i_p	μA	↓	1.4	1.2	1.3	1.4	1.4	1.3	1.3	1.4	1.4	1.1
f_{0dB}	MHz	↓	242	260	269	263	250	261	268	273	305	171
pm	°	↑	74	73	73	75	76	70	65	73	66	79
am	dB	↑	-25	-25	-26	-25	-28	-25	-20	-25	-24	-28
transistor			mw / l ratio									
main differential pair			290	350	290	290	230	350	290	290	410	230
auxiliary p differential pair			28	22	22	16	16	16	28	28	22	28
auxiliary n differential pair			14	20	8	8	11	14	20	20	11	11

Notations: A ... area, v_{pp} ... peak-to-peak voltage, v_{pp}/v_{inpp} ... dc gain, $cmfb_{offset}$... common mode feedback offset, i_p ... current consumption, f_{0dB} ... frequency at 0dB gain, pm ... phase margin, am ... amplitude margin, m transistor multiplier, w channel width and l channel length. Symbols ↑ and ↓ indicate that the desired value is as high or as low as possible.

Table 2: Results of some successful optimization runs for telescopic cascode amplifier (0.3 μm technology)

new information about the cost function shape in the multidimensional parameter space. Different local minima are found, if they are present. Multiple solutions are obtained providing additional insight into circuit behaviour. The designer can decide which one is the most appropriate and continues his/her work from there with finetuning. Fine-tuning is usually necessary since the obtained minimum of the cost function not necessarily satisfies the designer's expectations. A statistical model of the cost function was presented. The construction of cost function itself /12/ is beyond the scope of this paper.

The method takes into account all collected cost function data. Therefore all calculated points must be stored and some additional MBytes of RAM are occupied for that reason. But on the other hand it requires only a small computing effort and does not take a considerable amount of time. The optimization method used in the individual runs can be an arbitrary fast greedy (local) method. Fast convergence of such methods ensures short runtimes since global methods (like simulated annealing or genetic algorithms etc.) have in general slow convergence. More information is obtained instead of a single minimum. Our method can try several different initial points in the time needed by a global method to converge.

6 References

- /1/ M.G.R. Degrauwe et al., "IDAC: An interactive design tool for analog CMOS circuits," *IEEE J. Solid-State Circuits*, vol. sc-22, no. 6, Dec. 1987, pp. 1106-1116
- /2/ R. Harjani, R.A. Rutenbar and L.R. Carley, "OASYS: A framework for analog circuit synthesis," *IEEE Trans. Computer-Aided Design*, vol. 8, no. 12, Dec. 1989, pp. 1247-1266
- /3/ H.Y. Koh, C.H. Séquin and P.R. Gray, "OPASYN: A compiler for CMOS operational amplifiers," *IEEE Trans. Computer-Aided Design*, vol. 9, no. 2, Feb. 1990, pp. 113-125
- /4/ J.P. Harvey, M.I. Elmasry and B. Leung, "STAIC: An interactive framework for synthesizing CMOS and BiCMOS analog circuits," *IEEE Trans. Computer-Aided Design*, vol. 11, no. 11, Nov. 1992, pp. 1402-1417
- /5/ R.K. Brayton, G.D. Hachtel and A.L. Sangiovanni-Vincentelli, "A survey of optimization techniques for integrated-circuit design," *Proc. IEEE*, vol. 69, no. 10, Oct. 1981, pp. 1334-1364
- /6/ W. Nye et al., "DELIGHT.SPICE: An optimization-based system for the design of integrated circuits," *IEEE Trans. Computer-Aided Design*, vol. 7, no. 4, Apr. 1988, pp. 501-519
- /7/ S.W. Director and G.D. Hachtel, "The simplicial approximation approach to design centering," *IEEE Trans. Circuits Syst. I*, vol. cas-24, no. 7, July 1977, pp. 363-372
- /8/ K.J. Antreich and R.K. Koblitz, "Design centering by yield prediction," *IEEE Trans. Circuits Syst. I*, vol. cas-29, no. 2, Feb. 1982, pp. 88-96
- /9/ P. Feldmann and S.W. Director, "Integrated circuit quality optimization using surface integrals," *IEEE Trans. Computer-Aided Design*, vol. 12, no. 12, Dec. 1993, pp. 1868-1879
- /10/ K.J. Antreich, H.E. Hraeb and C.U. Wieser, "Circuit analysis and optimization driven by worst-case distances," *IEEE Trans. Computer-Aided Design*, vol. 13, no. 1, Jan. 1994, pp. 57-71
- /11/ A. Dharchoudhury and S.M. Kang, "Worst-case analysis and optimization of VLSI circuit performances," *IEEE Trans. Computer-Aided Design*, vol. 14, no. 4, Apr. 1995, pp. 481-492
- /12/ Á. Bürmen et al., "Automated robust design and optimization of integrated circuits by means of penalty functions," *Int. J. Electron. Comm.*, accepted for publication
- /13/ M. del Mar Hershenson, S.P. Boyd and T.H. Lee, "GPCAD: A tool for CMOS op-amp synthesis," *1998 IEEE/ACM Int. Conf. Comput.-Aided Design*, New York, 1998, pp. 296-303
- /14/ ———, "Optimal design of a CMOS op-amp via geometric programming," *IEEE Trans. Computer-Aided Design*, vol. 20, no. 1, Jan. 2001, pp. 1-21
- /15/ G. Gielen et al., "An analogue module generator for mixed analogue/digital ASIC design," *Int. J. Circuit Theory and App.*, vol. 23, no. 4, July-Aug. 1995, pp. 269-283
- /16/ G.G.E. Gielen, H.C.C. Walscharts and W.M.C. Sansen, "Analog circuit design optimization based on symbolic simulation and simulated annealing," *IEEE J. Solid-State Circuits*, vol. 25, no. 3, June 1990, pp. 707-713
- /17/ E.S. Ochotta, R.A. Rutenbar and L.R. Carley, "Synthesis of high-performance analog circuits in ASTRX/OBLX," *IEEE Trans. Computer-Aided Design*, vol. 15, no. 3, Mar. 1996, pp. 273-294
- /18/ G. Debyser and G. Gielen, "Efficient analog circuit synthesis with simultaneous yield and robustness optimization," *1998 IEEE/ACM Int. Conf. Comput.-Aided Design*, New York, 1998, pp. 308-311
- /19/ R. Schwencker et al., "Automating the sizing of analog CMOS circuits by consideration of structural constraints," *DATE Conf. and Exhibition*, 1999, Los Alamitos, 1999, pp. 323-327
- /20/ R. Phelps et al., "Anaconda: simulation-based synthesis of analog circuits via stochastic pattern search," *IEEE Trans. Computer-Aided Design*, vol. 19, no. 6, June 2000, pp. 703-717
- /21/ T. Mukherjee, L.R. Carley and R.A. Rutenbar, "Efficient handling of operating range and manufacturing line variations in analog cell synthesis," *IEEE Trans. Computer-Aided Design*, vol. 19, no. 8, Aug. 2000, pp. 825-839
- /22/ F. Schenkel et al., "Mismatch analysis and direct yield optimization by spec-wise linearization and feasibility-guided search," *Proc. 38th DAC*, New York, 2001, pp. 858-863
- /23/ P. Mandal and V. Visvanathan, "CMOS op-amp sizing using a geometric programming formulation," *IEEE Trans. Computer-Aided Design*, vol. 20, no. 1, Jan. 2001, pp. 22-38
- /24/ J. Nocedal, "Theory of algorithms for unconstrained optimization," *Acta Numerica*, vol. 1, 1992, pp. 199-242
- /25/ A.R. Conn et al., "JiffyTune: circuit optimization using time-domain sensitivities," *IEEE Trans. Computer-Aided Design*, vol. 17, no. 12, Dec. 1998, pp. 1292-1309
- /26/ M.H. Wright, "Direct search methods: once scorned, now respectable," *Proc. 1995 Dundee Biennial Conf. in Numerical Analysis*, 1995, pp. 191-208
- /27/ M.J.D. Powell, "Direct search algorithms for optimization calculations," *Acta Numerica*, vol. 7, 1998, pp. 287-336
- /28/ R.M. Lewis, V. Torczon and M.W. Trosset, "Direct search methods: then and now," *J. Computational and Applied Math.*, vol. 124, no. 1-2, Dec. 2000, pp. 191-207
- /29/ V. Torczon, "On the convergence of pattern search algorithms," *SIAM J. Optimization*, vol. 7, no. 1, Feb. 1997, pp. 1-25
- /30/ F. Romeo and A. Sangiovanni-Vincentelli, "A theoretical framework for simulated annealing," *Algorithmica*, vol. 6, no. 3, 1991, pp. 302-345
- /31/ A.W. Johnson and S.H. Jacobson, "On the convergence of generalized hill climbing algorithms," *Discrete Applied Math.*, vol. 119, no. 1-2, June 2002, pp. 37-57
- /32/ A.G. Zilinskas, "On statistical models of complex multimodal functions and their application to the design of optimization algorithms," *Problems of Control and Inform. Theory (English translation)*, vol. 10, no. 1, 1981, pp. 19-30

- /33/ R. Buche and H.J. Kushner, "Rate of convergence for constrained stochastic approximation algorithms," *SIAM J. Control and Optimization*, vol. 40, no. 4, 2001, pp. 1011–1041
- /34/ J.R. Koza et al., "Automated synthesis of analog electrical circuits by means of genetic programming," *IEEE Trans. Evol. Comput.*, vol. 1, no. 2, July 1997, pp. 109–128
- /35/ ———, "Synthesis of topology and sizing of analog electrical circuits by means of genetic programming," *Comput. Methods in Applied Mechanics and Eng.*, vol. 186, no. 2–4, June 2000, pp. 459–482

Janez Puhan, Árpád Búrmen and Tadej Tuma
University of Ljubljana
Faculty of Electrical Engineering
Tržaška 25, SI-1000 Ljubljana
E-mail: janez.puhan@fe.uni-lj.si

Prispelo (Arrived): 28.03.2003 Sprejeto (Accepted): 26.08.2003