

# Proučevanje konstruiranja proizvodnih strojev s postopkom temelječim na modeliranju omejitev

## A Constraint-Based Limits-Modelling Approach to Investigate Manufacturing-Machine Design Capability

Jason Matthews - Baljinder Singh - Glen Mullineux - Tony Medland  
(University of Bath, United Kingdom)

*Proizvajalci kupujejo proizvodne stroje, ki so zmožni obdelave nekega izdelka v določenem obdobju. Izdelki, ki se izdelujejo na teh strojih, pa se lahko zamenjajo v dobi trajanja stroja. Proizvajalci se pogosto obračajo na prvotnega proizvajalca opreme, da ocenijo zmožnost prilagoditve stroja na različico izdelka ali celo obdelavo povsem drugega izdelka. V Veliki Britaniji so proizvajalci take opreme majhna podjetja z največ 80 zaposlenimi. S tako omejenimi zmogljivostmi ni zadosti strokovnosti ne časa za izvajanje podrobne analize, kako izboljšati učinkovitost strojev. V preteklosti je bilo zato treba kupiti nove stroje, kar pa je pomenilo velik finančni zalogaj za podjetja, ki so želela predstaviti nove izdelke na že tako konkurenčnem tržišču. Ta prispevek predstavlja postopek raziskave proizvodne zmožnosti nekega stroja. Metodologija sloni na modeliranju omejitev in uporablja možnosti omejenega okolja za modeliranje variantnih oblik in omogoča primerjavo njihove odpornosti na neuspeh. Ta postopek omogoča izdelavo različnih grafičnih predstavitev tehnik, ki prikažejo in primerjajo omejitvene pogoje za vse stroje.*

© 2007 Strojniški vestnik. Vse pravice pridržane.

**(Ključne besede: konstruiranje strojev, prilagajanje izdelkom, modeliranje omejitev, izboljšanje učinkovitosti)**

*Manufacturers purchase processing machinery, tailor made to handle a specific, limited product range. However, during the life span of the machines, these products are likely to change. The manufacturer often calls on the original equipment supplier to assess the ability of the machines to process either a variant of their existing range or even to consider the handling of a totally new product. In the UK such equipment manufacturers tend to be small concerns, employing 80 staff or less, and with such limited resources that there is not the expertise or time available to perform any in-depth analysis of how well the design operates or what constraints there are that may stop it reaching the new performance requirement. In the past this has led to the manufacturers purchasing new equipment, which puts a high financial burden on companies wishing to introduce new products into already highly competitive market sectors. This paper presents an approach to investigating the manufacturing capability of a machine. The methodology, based on limits modelling, utilizes the capability of a constraint environment to model multiple variations of a design and compare their performances against a range of failure modes. This process allows a variety of graphical visual representation techniques to be created to illustrate and compare the limiting conditions for all machines.*

© 2007 Journal of Mechanical Engineering. All rights reserved.

**(Keywords: machine designs, product variations, modeling limits, constraints)**

### 0 INTRODUCTION

All process machinery, whether from food processing, automotive sub-component assembly or electrical device sectors, is designed with an innate capability to handle slight variations in the product. This is initially achieved by simply providing tolerances to allow, for example, changes

that occur in pack sizes to be accommodated, through user adjustments or complete sets of change parts. By the appropriate use of these approaches most normal variations in product setting can be handled. However, when extreme conditions of setting, major changes in product size and configuration are considered there is no guarantee that the existing machines will be able to cope. The

problem is even more difficult to predict when completely new product families are proposed for manufacture on an existing product line.

Such changes in product range are becoming more common as producers respond to demands for ever increasing customization and product differentiation. Within the process and packaging industries this is often achieved through changes in product-packaging formats, numbers in a pack and the types of presentation employed, particularly in supermarkets [1]. All result in the supplier being forced to make more and more frequent changes to the line with little to no guidance on how this can be achieved (or even if it is at all possible). The lack of knowledge about the capabilities of the machines being used forces the supplier to undertake a series of practical product trials. These, however, can only be undertaken once the product form has been decided and produced. There is then little opportunity to make changes that could greatly improve the potential output of the line and to reduce waste.

The production machines in question are generally constructed of multiple *spatial mechanisms* [2]. The machines are known to work but a full understanding of their design implications and capabilities are not available. This can mean that problems may occur if a customer wishes to purchase a machine to handle a product form that has not been encountered before. In the packaging sector this may be the case when a product with a size larger than normal needs to be wrapped. Often the response is to take a known machine and produce a variant design that can handle the new product. This means that the company is then committed to supporting that variant throughout its operating life. However, if a better understanding of the full range of machines was available, then an existing machine might be identified to handle the new product. Similarly, if that understanding was available, it would help to rationalize the existing range of machines so that the full spectrum of products could be catered for without significant duplication.

There is thus a need for a modelling approach that allows the effect of variation in products to be analyzed together with an understanding of the capability of the manufacturing machine. Only through their analysis and interaction can the capabilities be fully understood and refined to make production possible.

The remainder of the paper is structured as follows. Section one gives a critical overview of the related literature and technologies, and presents the rationale for the approach presented. Section two gives an overview of the constraint modelling environment. In section three the limits modelling approach is presented, along with a flowchart. The methodology is implemented in section four with a packaging-machine case study. A discussion of the approach is given in section five. The research is concluded in section six, including the limitations of the approach and future work.

## 1 BACKGROUND

### 1.1 Mechanism / machine analysis

This section provides a review of the relevant academic and commercial approaches that have been employed to investigate and analyse the functionality and performance of both machines and their constituent mechanisms. The limitations of these are discussed at the end of the section. The analysis of position and kinematics for mechanisms' limits has been well documented ([2] to [5]). Increased computational power now allows designers to model, analyze and simulate complex mechanisms. Simulation is widely reported [6] and [7], often utilizing standard packages for a design-through-simulation approach. These are generally used to evaluate the performance capabilities of a particular configuration during the machine's operation cycle. Commercial CAD packages ([8] and [9]) allow the designer to model and undertake motion analysis (both kinematic and dynamic), together with component interaction. Other packages such as ADAMS [10] allow the engineer to interactively undertake investigations of mechanical, pneumatics, hydraulics, electronics, systems as well as investigating other effects such as forces, noise, vibration, and harshness. In addition to these, higher-level CAE packages ([11] to [13]) offer the engineer the option to explore the design space by implementing parametric studies and provide sensitivity analyses to allow the engineer to compare the effects of several parameters on chosen responses. Such packages can give the engineer the option to optimize selected effects of parameter change by combining design-of-experiments methods. Hicks et al. [14] described a methodology using a constraint modelling

environment for supporting and analyzing the design of packaging machinery at the embodiment stage. This method showed the ability of the modelling package to analyze the design of a mechanism. Hicks et al. [15] extended this approach into optimal redesign of packaging machinery. In [16] Barton and Lee created a framework for the modelling, simulation and optimization of hybrid systems. Pusey et al. [17] developed a graphical interface, "BONK", to simplify the preparation and analysis of dynamic systems using Bond graphs. Their approach bounded the maximum and minimum kinematics properties for the given mechanism and optimized the mechanism to find the best solution.

The above methods analyze the design and its motions. Another area of research undertaken for the robotics industry forms the methods of understanding the limits of reach and motion for robots and manipulator mechanisms, in their configuration space (c-space) [18]. Through this an area, termed the workspace, can be defined, which represents the maximum limiting motion for the device. Research in [19] studied the design and workspace of a 6–6 cable-suspended parallel robot. This characterized the workspace volume as the set of points that the centroid of the moving platform can reach with tensions in all suspension cables at a constant orientation. An approach has also been developed that uses an algorithm to plot clouds of points to represent the workspace boundaries of a robot system [20]. These defined the cloud boundaries and are connected together to give the real workspace. Research in [21] devised a general method for workspace computation based on a geometric sweep of the spatial elements, representing partial workspaces. The geometric algorithms developed by Gosselin [22] define the geometric boundary edges of a dexterous robot together with the total orientation, maximal and fixed orientation workspaces by considering the limits of the actuators. The authors of [23] and [24] presented geometrical methods for the constant-orientation workspace of a hexa-slide manipulator, and developed an algorithm to reverse design a Gough platform from knowing the workspace.

## 1.2 Constraint-based approaches

It is evident from the research reviewed above that there are currently a variety of underlying

methods for application assessment, analysis and problem solving, that could be applied to the issues discussed in this paper. The main reason for this stems from the fact that particular tools or techniques are frequently driven by the perspective of the particular problem and how it is to be solved rather than a generalized approach for reasoning about the problem. It is arguable that such variety makes the use, integration, exchange and unification of supportive tools, methods and processes (process elements) particularly difficult. This contributes to many of the research challenges now facing academia and industry [25]. In order to create a generalized approach for both modelling and reasoning a constraint-based approach was investigated. This has recently been applied to a range of different tasks associated with design and manufacture and forms the background to the approach adopted for the work presented in this paper.

Within the context of this research a constraint is defined as a rule that can be analyzed to determine its current 'truth'. This may take on many forms, which may, for example, determine a bound on a single design parameter, express the relationship between a set of design parameters or be any factor that limits the performance of a system. With a constraint-based approach the identified parameters and constraints for a problem can be specified and their consequences investigated [26]. Constraints take two forms: quantitative and qualitative. Quantitative constraints are perhaps the easiest to visualize. They are requirements that particular parameters must take specific numerical values at prescribed points or over prescribed regions. Qualitative constraints are requirements for the value of a parameter to be in an inequality relation with respect to a second parameter.

There are three distinct methods for working with constraints: satisfaction, optimization and checking [27]. With constraint satisfaction the aim is to find a configuration that satisfies all the imposed constraints as closely as possible. An extension to this is the constraint-optimization problem. Here constraints are used to find the optimum solution to a problem. Constraint optimization and satisfaction have become the dominant approaches for design ([27] and [28]), especially of mechanisms [29], machines [13] and [14] and for manufacturing problems, such as

computer-aided process planning ([30] and [31]) and scheduling [32]. For the optimization or satisfaction of constraints there are several techniques including, for example, numerical optimization [33], symbolic manipulation and re-ordering strategies [34], simulated annealing [35] and evolution strategies such as genetic algorithms [30].

The third approach, constraint-checking, is a passive technique that monitors whether a constraint has been violated. Previous research has employed this method for real-time modelling of industrial floor layouts. The authors considered the design rules and physical limitations as constraints. The Open Scheduling Architecture (TOSCA) developed by Beck [36] was used to address manufacturing scheduling problems from a constraint-based perspective. The constraints were monitored in terms of threats to their satisfaction and are opportunistically tackled through a process that iteratively refines the schedule by restricting the resourcing and start-time options. The authors of [37] use the constraint language SPARKS to check for constraint violation in constraint networks produced for concurrent engineering. A similar approach was employed by [38] for product life-cycle design. The constraint-checking approach has advantages over the other two methods, as it offers greater flexibility and requires less computational power. In a design scenario it also takes advantage of the engineer's knowledge and experience.

### 1.3 Background work discussion

The simulation and modelling approaches identified above perform well when describing the physical geometrical extremes and configuration space of the mechanism and/or the machine. They offer the user the ability to analyze motion and to explore the design space of a given system. If individual analysis tools and methods are employed for a detailed investigation of a particular machine or mechanism, then the ability to generate an optimum or best-performing design solution is severely frustrated [13]. With the tools and methods reviewed there are fundamental limitations, because:

- they allow no consideration of other modes of failure or limits,
- the user is constrained by the functions offered by the respective system for modelling and simulation attributes,

- even through the user has modelled the design, the tool may not allow complete access to the underlying constraints, which are fundamental to this approach.

With these factors in mind it is evident that there is currently no approach to answer the specific industrial question posed in this research. Further research into this area is required to establish a methodology where the whole performance of a system can be defined and analyzed to assess its ability to handle change. A constraint-based system has been selected for this research because of the flexibility it allows: it offers parametric modelling, which is paramount to this approach, it allows motion and element interaction to be performed, its inbuilt functions give the option of a sensitivity analysis [39] and the constraint-based approach using hard and soft constraints [40] allows for optimization. The programming environment also permits the user to employ constraint checking while actuating models. To aid readability the term *system* is used in the remainder of the paper to describe both the machine and its constituent mechanisms.

## 2 MODELLING APPROACH

### 2.1 Constraint-modelling environment

This section gives an overview of the constraint-based approach used here and shows how systems can be modelled in the environment. In constraint-based modelling the identified constraints and parameters from a design can be specified and their consequences investigated. This holistic approach allows the representation of design knowledge and, more importantly, enables this knowledge to be expanded or modified at any stage during the design process. In this way changes in both the proposed solution and in the governing constraints of the particular design problem can be dealt with and investigated. The software has its own user language, which has been created to handle design variables of several types, including structured forms to represent, for example, geometric objects. The language supports user-defined functions. These are essentially collections of commands that can be invoked when required. Input variables can be passed into a function and the function itself can return a single value or a sequence of values. Functions are used to impose

constraints using an important in-built function, which is the “*rule*” command. Each rule command is associated with a constraint expression between some of the design parameters, which is zero (as a real number) when true. A non-zero value is a measure of the falseness of the constraint rule.

With satisfaction and optimization techniques, in order to investigate the effects of the constraints, they need to be resolved. There are several techniques for doing this ([28] and [34]), including, for example, symbolic manipulation and reordering strategies. The method used by the constraint modeller is based on optimization techniques. During the resolution the expression for each constraint rule (within a function) is evaluated and their sum of the squares is found. If this is already zero, then each constraint expression represents a true state. If the sum is non-zero, then resolution commences. This involves varying a subset of the design parameters specified by the user. The sum is regarded as a function of these variables and a numerical technique is applied to search for values of the parameters that minimize the sum. If a minimum of zero can be found, then the constraints are fully satisfied. If not, the minimum represents some form of best compromise for a set of constraints that are in conflict. It is

possible at this stage to identify those constraints that are not satisfied and, where appropriate, investigate whether relaxing less important constraints can enable an overall solution to be determined. Constraint checking can be implemented when simulation or numerical models are being actuated. The constraints can be either equality or inequality in nature, with relationship functions being employed to check if these constraints are being violated.

For simulation-based models the software environment supports simple wire-frame graphics, such as line segments and circular arcs. These can be defined in a world space or associated with a ‘model space’ [41]. The model spaces can be embedded within each other. The modeller also has the capability to create solid objects. These can be embedded within model spaces [42] so that they can move with other geometries, including wire-frame entities. Solids have been incorporated into the environment by means of the ACIS library of procedures [43].

As an example, consider the representation of a four-bar linkage. This is shown schematically in Figure 1. In part (a) of the figure the two fixed pivot points are specified, and the line segments representing the three links are defined, each in a

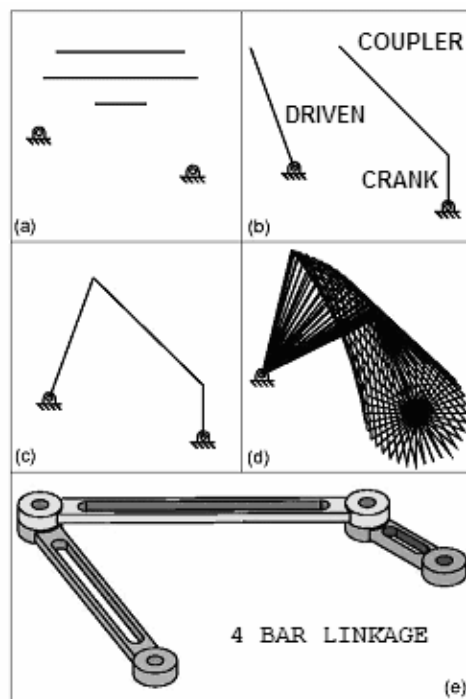

Fig. 1. Modelled four-bar mechanism

local model space. Here a model space is a group of entities with which a transform is associated. This transform dictates how the entities map, from their own local coordinates into world space or into another model space. In this way a hierarchy of model spaces can be set up and used to specify an initial assembly of some components of a design. In the example, the model space of the coupler link is “embedded” in the space of the crank, and the spaces for the crank and the driven links are embedded in world space. A partial assembly of the mechanism is achieved by applying the transformations to the links in each space. This is shown in part (b) of Figure 1. If the space of either the crank or the coupler is rotated, the hierarchy of their spaces ensures their ends remain attached. To complete the assembly, the ends of the coupler and driven link have to be brought together. This cannot be done by model space manipulation alone, as this would break the structure of the model space hierarchy. Instead a constraint rule is applied, whose value represents the distance between the ends of the lines. The user language has a binary function ‘on’, which returns the distance between its two geometric arguments. If  $l_1$  and  $l_2$  are the lines for the coupler and the driven links, then, in the user language, the constraint rule is expressed as follows:

```
rule ( l1:e2 on l2:e1 );
```

where the colon followed by e1 or e2 denotes either the first or second end-point of the line. In order to satisfy this constraint rule the system is allowed to

alter the angle of rotation of the model spaces of the coupler and driven links. When the rule is applied the correct assembly is obtained as in part (c) of Figure 1. When the space of the crank link is rotated and the assembly of the other two links is performed at each stage, a step-wise simulation of the motion is obtained, as in part (d). If solid objects representing the link are constructed, these can also be included in the model spaces, as shown in part (e).

### 2.2 Mechanism system effects

To investigate the effects of product change, the factors which cause the system to fail need to be identified. For this purpose a study of the factors that cause such failures [44] was made and these are represented in the Ishikawa diagram, Figure 2. These factors represent the constraints of the system and are agreed with the designer/engineer, possibly informed by testing of the product.

In addition to these, the constraints which need to be employed for the constraint checking have to be established. Again, many of these can be identified by the designers and engineers of the manufacturing company. However, in addition to this, some modelling of the product is likely to be required, to establish its bounds to processing.

### 3 LIMITS MODELLING

The problem of investigating the inherent and potential manufacturing capability of a machine, defined in the introduction, requires an approach to find a solution. This paper presents a

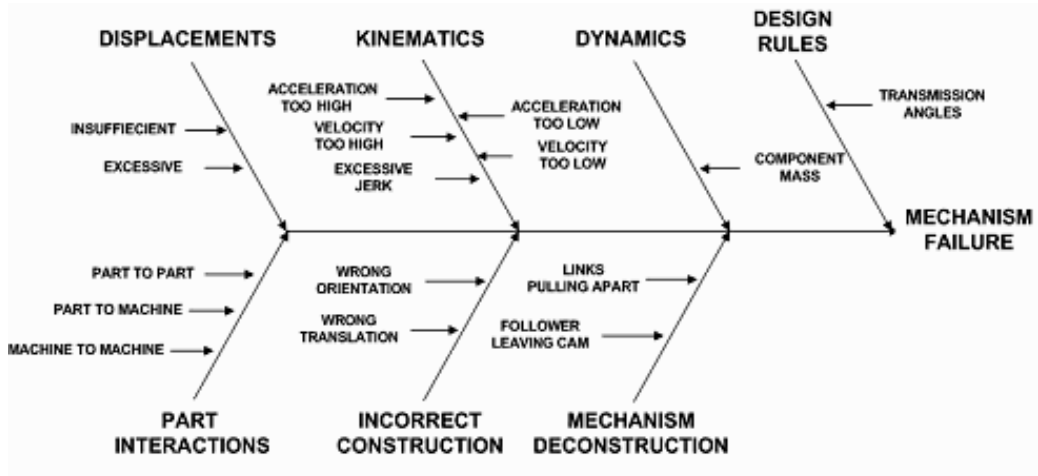

Fig. 2. Ishikawa diagram of system failures

technique called “limits modelling” as one possible alternative. The approach being adopted is, to work with a parametric model of a machine established within the constraint modelling environment [41]. The effects of variations within the machine can be investigated by adjusting suitably chosen parameters. Such variations can represent the effects of adjustments within the physical machine and the use of change parts.

### 3.1 The method

The system is parametrically modelled using an environment such as the constraint-modelling package, as described in Section 2. The dimensions for the modelling are taken from a part drawing (if they exist), manual measurements and high-speed video footage. Two inherent capabilities of the constraint-modelling package are employed to test the appropriateness of the model. Working with the designers or users of the actual machine, the possible failure modes are established.

- *Bounded search.* The search capability of the modeller is employed to establish whether the device is within the global limits set for the system. Examples of such limits can be the geometric footprint of the machine and cost factors. This gives a crude investigation, showing whether the system has functionality and is appropriate to undergo the limits-modelling process.
- *Sensitivity analysis.* This is the procedure of incrementing design parameters and examining the relative changes in the model’s response. When small changes in a parameter of a system result in relatively large changes in the outcomes, the parameter is deemed sensitive. This information is then used to decide the important parameters to investigate during the limits-modelling approach.

With the models’ appropriateness tested the next stage is establishing the constraints to be employed for the constraint checking. A variety of techniques can be employed within the modeller to check the violations of these constraints. For example, one failure mode may be the clashing of parts of the machine with each other or with the product. Here an interference check between solid objects within the model can be undertaken. An alternative is bounded boxes, where a box is a rectangular block that contains an object throughout

its motion. When a change to the product necessitates a modification to a design and this modification causes the motion to exceed any of the walls of the box, then it can be concluded that this product cannot be processed using this system. Although this is crude, it is an approach that is sufficiently reliable for certain applications, such as an investigation of the extreme motions for a mechanism within a defined machine footprint. The next stage is to run the model repeatedly for different configurations (multiple instances), with each being tested for successful operation. This allows a matrix of functional points to be generated. When the model is being tested, performance characteristics can also be logged into the matrix. For this process two approaches can be employed.

- *Program modeller to disturb the dimensions of the model:* The variables within the model can be programmed to vary in dimensionality. A strategy for the disturbance has to be decided on prior to this step. This approach is only suitable for simplistic mechanisms with a small number of variables.
- *Set goal and make use of the modeller’s optimizing function:* The internal optimizer with the constraint modeller can be used when a goal is set for the model. The modeller will iteratively optimize the model; all successfully functioning instances can be recorded to produce the functional matrix.

With the matrix defined, a crude method to test whether a new product configuration is such that it lies within the limits of the system is to search for the closest point to the new configuration. In this way the performance values can be used to find the best solution. If the values of the new configuration are greater than those recorded within the matrix then it can be assumed that the new product cannot be produced with this system/machine

### 3.2 Results representation

The first representation of the functional points comes from the functional matrix, which can have the performance factor associated with them. It can also be useful to have the data from the matrix in a more graphical representation. The following are some of the options that have been employed for different limiting modelling design exploration situations.

- *Cloud Plot*: is a multi-dimensional scatter-gram. The 2D and 3D variants of this diagram are normally associated with statistical analyses and the presentation of data, for example, in the study of geophysical data [41]. However, recently scatter-grams have also been used as a tool for linking scientific and information visualizations. In this methodology, each successful entry in the matrix relates to a point plotted on the cloud map. The cloud map gives a visual representation of the function space of the system. The boundaries of the cloud map are the limit conditions for the system.
- *Convex Hull*: The convex hull for a set of data is the minimal convex shape containing the given data. It is simple to produce a convex hull from the data plotted from the cloud map in MATLAB; it also allows the volume and surface area of the hull to be computed. When a new configuration is required and the new point is plotted into the data set it can be compared with the original hull. If the volume or surface area has increased, then the new configuration lies outside the limits of the system. The use of the convex hull is suitable when the data set is large and closely grouped. Similar convex hulls have been successfully employed when representing

the configuration space of the robot manipulators [21]. As with the cloud plot, the convex hull process can be extended to a range of machines for comparisons.

- *Failure-mode map (FMM)*: This approach has been created from the limits-modelling approach. Effectively, the approach is used to perform an exhaustive search of the design area against a given setup, performance and function factors. The approach records points where the system functions correctly and where the constraints are violated. These violations are recorded and plotted. This offers the user the potential to see the given boundary for the system and the constraints that limit any other development (cf figure 3a).
- *Surface plot*: A multi-dimensional surface can be fitted to the categorized data variables. Surfaces for subsets of data determined by the selected categorization method can be arranged in one display to allow for comparisons between the subsets (cf. figure 3b).

This approach also opens up the possibility of redesigning the original machine so as to maximize its allowable space. Here, constraint-based techniques and optimization can again be used. Now, more of the fundamental design

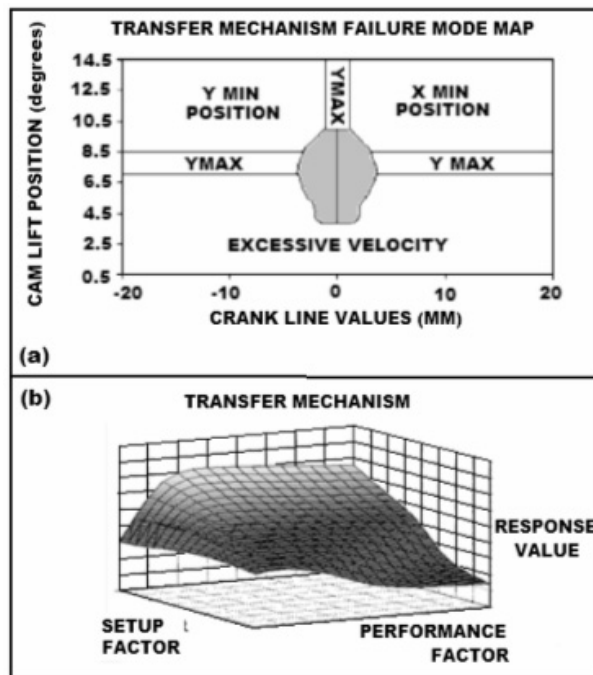

Fig. 3. Results representation



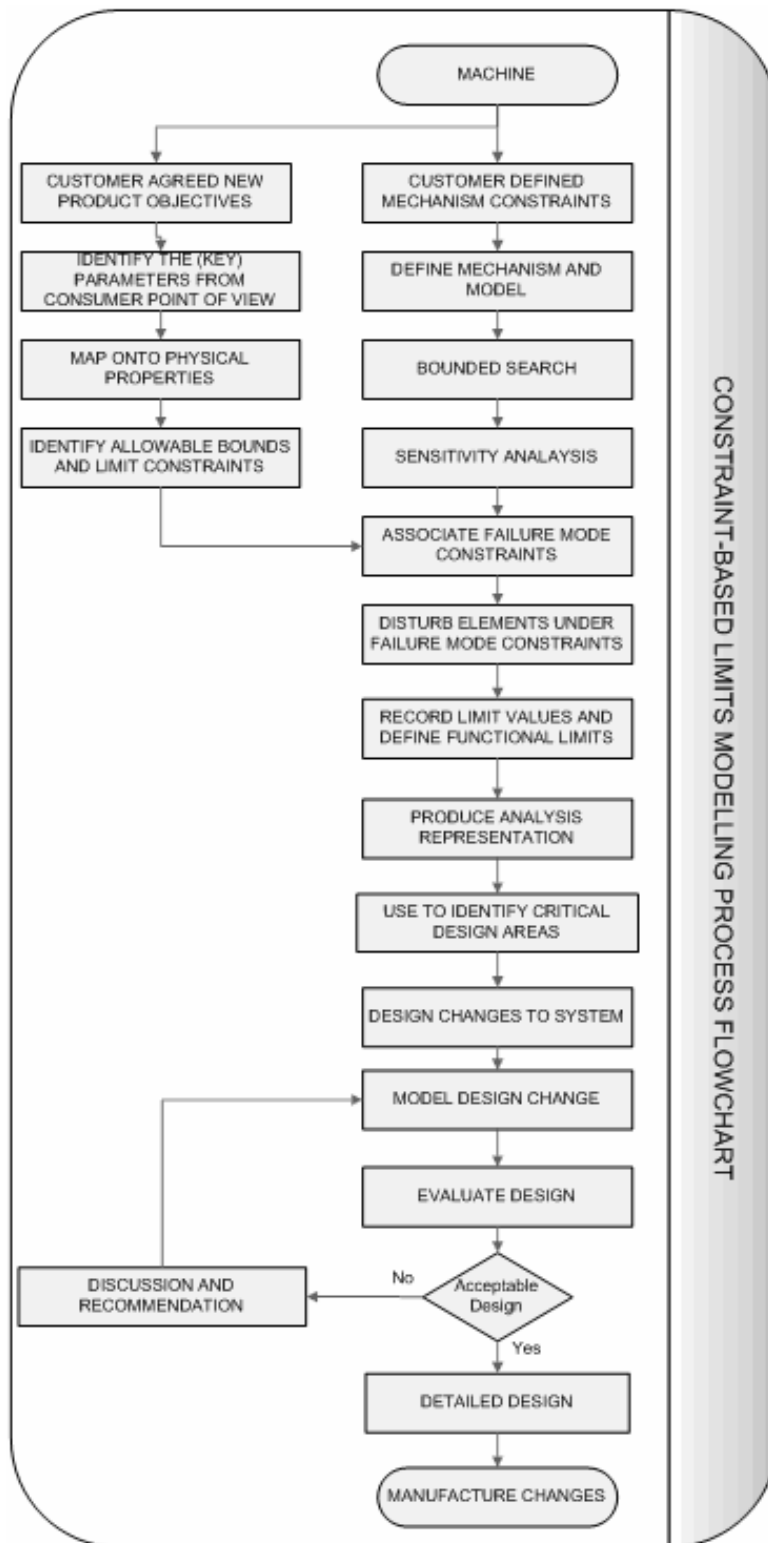

Fig. 4. Methodology flowchart

geometry is varied with the aim of increasing the volume of the allowable space obtained when the machine adjustments are varied. This then allows a more general-purpose machine to be designed and can permit the number of machines in a given family to be reduced. The complete approach is presented in the flowchart in Figure 4.

#### 4 CASE-STUDY EXAMPLE

##### 4.1 The system

The featured system is an ejection sub-assembly of a confectionary-wrapping machine (Figure 5). The confectionary is fed into the machine via a rotary table together with the film being fed by a de-reel unit. The confectionary and film are then lifted together into transfer gripper jaws. This operation also cuts the film to the correct length. The gripper jaws transfer the confectionary into the wrapping station. At this point two rotary-driven grippers clamp the film and twist, thus sealing the confectionary. From this station the gripper jaws transfer the wrapped confectionary to the ejection station. The function of this sub-mechanism is to push the wrapped confectionary from the transfer grippers onto a chute where the confection exits the machine.

##### 4.2 Modelling and testing

In this study the physical measurements of the system were taken, and the operation was recorded with high-speed video footage. The system was then modelled using the constraint-modelling package.

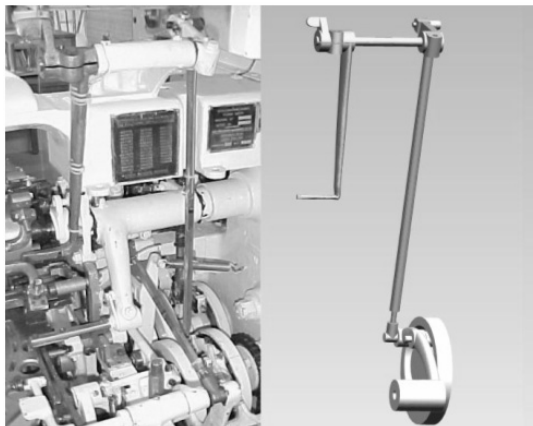

Fig. 5. Ejection system

The resultant model was then compared with the high-speed video footage to verify the functionality. Figure 6 shows the ejection system modelled within the constraint modeller. The ejection system consists of a cam-driven four-bar chain with two fixed pivot points. The roughly circular form at the base of the model is the drive cam. The cranked arm attached to the fixed pivot point and resting on the drive cam is the cam follower. The upright line is the pushrod. The link is the line spanning the top of the pushrod and the top, fixed pivot point. The line descending from the top, fixed pivot point is the ejection arm.

##### 4.3 Establish failure-mode constraints

With the model produced and tested the next stage was to define the factors that stop the model from functioning. The following failure modes were established for this example.

To identify when the limits (e) and (f) occur, hard limits are applied in the constraint-modelling program for the Cartesian position of the relative parts. The logic takes the form of a relationship statement. When this statement is true, the actions in the brackets are performed. This takes the form of writing a message to the screen, highlighting the mode of failure. It was also decided at this point to have a flagging system. When the system is functioning correctly each failure mode has a default value of one. When the failure-mode constraint value is reached this value is switched to zero. An overall flag value for the system was created as the product of all the individual failure modes. While the system is functioning correctly

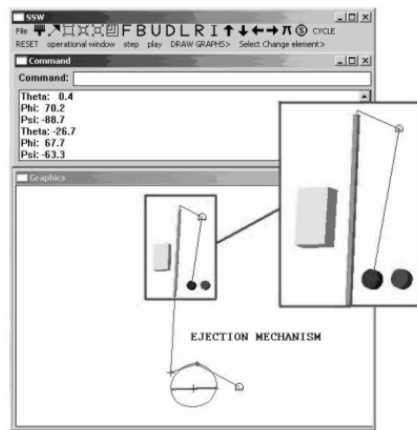

Fig. 6. Constraint-based model of system

Table 1. *Failure-mode constraints*

<b>System-driven failure-mode Constraints</b>	
<b>MODE</b>	<b>Description</b>
a	Ejection-arm movement is insufficient or incorrectly orientated to remove the confectionary
c	There is a breakage in the system
c	The pushrod interacts with the frame of the machine
d	The eject arm interacts with the pushrod of the system
e	The ejection-arm rest position is too far forward, causing a clash with other systems
f	Ejection-arm maximum position
<b>Component-driven failure-mode constraints</b>	
g	Excessive velocity

the default value is one. If any of the individual systems fail there its zero value will cause the overall system value to become zero. The constraint modeller performs assemblies by minimizing the error in constraint rules that represent the distance between parts. Its ability to do this can be used to access the success or failure of the assembly. The following function contains typical assembly rules. Once this “*assemble*” function has been invoked, the inbuilt function “*truth*” can determine its success (failure mode c). Cartesian positions recorded in model-simulation motion against time ratios are used to calculate the kinematics for the system, i.e., the failure mode (g). Solid elements are embedded into the model as a method for detecting the interaction of elements. Figure 6 shows the solid elements added to the ejection-system model. The four solid elements added to the model are the rectangular block to the left, which models the machine frame. The cylinder disc to the right of the model is the confectionary held in the machine jaws. The upright block on the pushrod is the body of the pushrod, and the cylinder disc at the end of the ejection arm is used to check the ejection-arm contact to the confectionary and the pushrod. The constraint modeller has the ability to identify the volumes of solid objects within a model using the ‘*volume*’ function and this capability is utilized to detect element interaction. This method is also employed for failure mode (d), to identify the interaction of the ejection arm to the pushrod. As the construction of the ejection arm only requires a partial interaction with the confection to dislodge it from the transfer jaws onto the ejection chute, a limit value was set to look for an interaction of the solid disc modelled on the end of the ejection arm and the solid disc representing the confectionary. If a value, lower than this figure was achieved then

the system was said to have failed under failure mode (a).

#### 4.4 Parametric variations of system elements

With the modes for failure defined within the model the next stage is to configure multiple instances for the ejection system, then to check these instances against the failure-mode constraints. An individual element is selected by the user, and this element is then incrementally increased or decreased in size. The size of the other elements that make up the system were then increased and decreased in combination with the original elements until the model reaches one of the failure modes for the system noted in Section 3.3. This process was repeated until all possible configurations of element increase and decrease have been explored. The values from increasing and decreasing the elements are recorded individually to give a matrix of the functionality limits against the individual size of other elements. The maximum and minimum values recorded for these elements give us the functionality boundaries of the system. The values from running multiple instances of the system provide us with a matrix of functional points. As the functional points were recorded, it is also possible to run the model with specific failure modes active. This allows the user to retain information on which failure is active under which conditions and how the parametric variation affects individual elements.

#### 4.5 The functional matrix

The matrix noted in Section 4.4 contains all the working points of the system. It can be seen from the partial matrix shown in Figure 7 that the working values can also have performance

ELEMENTS			PERFORMANCE		
n1	n2	n3	A1	J1	V1
385	-171	-165	1	-	1
385	-172	-165	1	-	1
385	-173	-165	2	-	1
385	-174	-165	2	-	1
385	-175	-165	2	-	1
385	-176	-165	2	-	1
385	-177	-165	2	-	1
385	-178	-165	2	-	1
385	-179	-165	2	-	1
385	-180	-165	2	-	1
385	-181	-165	2	-	1
385	-182	-165	2	-	1
385	-183	-165	2	-	1
397	-170	-165	2	-	1
398	-170	-165	2	-	1
399	-170	-165	2	-	1
400	-170	-165	2	-	1
401	-170	-165	2	-	1
402	-170	-165	2	-	1
385	-170	-162	1	-	1
385	-170	-161	1	-	1
385	-170	-160	1	-	1
385	-170	-159	1	-	0
385	-170	-158	1	-	0
385	-170	-157	1	-	0

Fig. 7. Functional matrix

characteristics associated with them. These values could relate to accelerations, velocities or jerk (the third time-derivate of motion).

As mentioned in Section 2.1, by searching for the closest point to the new configuration, the matrix can be used to test whether a new product configuration is such that it lies within the limits of the system. The performance values can be used as an aid to find the best solution.

The production of a visual model describing the limits of the functional envelope can be very useful when you are evaluating the machine's ability to handle product variation and when optimizing performance. This section shows how two examples, the cloud map and the convex hull, can visually represent the results from the testing of the ejection system.

#### 4.6 Cloud map plots

Figure 8 shows the cloud map plotted from the matrix in Figure 7. Each point plotted represents a line from the matrix. As noted previously, with the cloud map produced it becomes simple to test new configurations of the ejection system that may

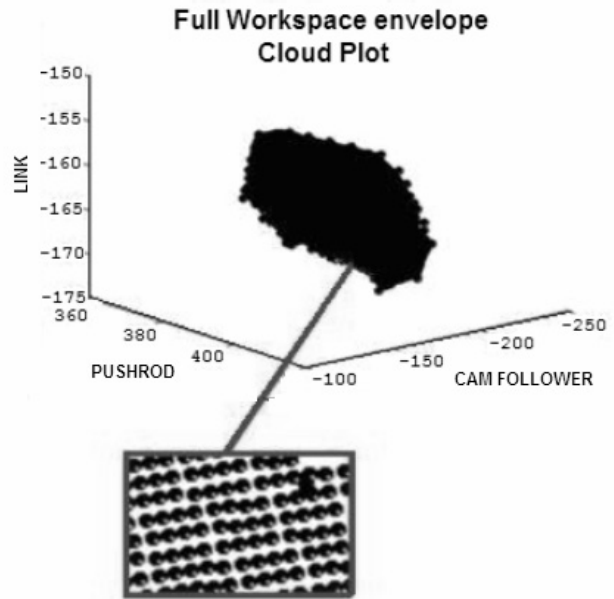

Fig. 8. Cloud plot

arise when new products need to be processed using the existing machine.

It is intended that future work with the methodology will centre on the usage of hyperplanes to dissect a modified cloud plot. This will give the option of using more than three elements for a change, while analyzing the system.

#### 4.7 Convex hull

With the cloud map plotted a follow-on stage is to produce the convex hull. Figure 8 shows the convex hull for the ejection system generated using MATLAB®. The advantage of the convex hull is that it reduces the visual 'clutter' associated with the cloud map and gives a visual representation that is easy to understand and to interrogate.

#### 4.8 Failure-mode plotting

It is also possible to run the model with the individual failure modes active. This allows the user to retain information on which failure is active under which conditions and how these effect the element variation.

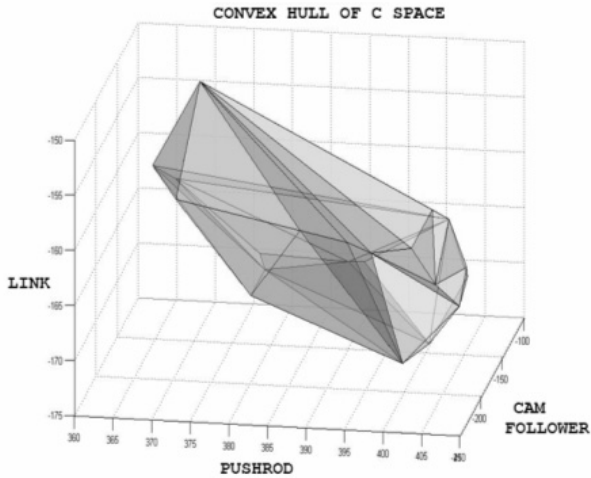

Fig. 9. Convex hull

### 5 DISCUSSION

The case study has been described showing the use of the methodology for investigating the limits of an ejection system from a confectionary-wrapping machine. With the allowable space established and presented in visual forms, Figures 8 and 9, it becomes a straightforward process to test whether a given new product is such that it lies within the space and hence can be handled with that machine. In particular, it is clear that:

- In the original configuration the link dimension was close to its minimum limit. If a reduction adjustment to this link was required for a variant product change, it is likely that the cam follower and the pushrod will need modifying as well.
- It is highlighted that the link element was also the most sensitive to adjustment when investigating modifications, with the cam follower being the least sensitive.
- The best solution for any given system could be found by using either the matrix or the cloud plot diagram.

Figure 10 shows two of the six plotted failure-mode graphs. These are plotted to investigate the effects of the failure mode on the individual elements. From these graphs it was shown that from the original system configuration:

- the sweet contact mode allows for a large variation in configuration,
- for frame contact mode, only an element increase is permitted,
- for the maximum position and eject arm to frame

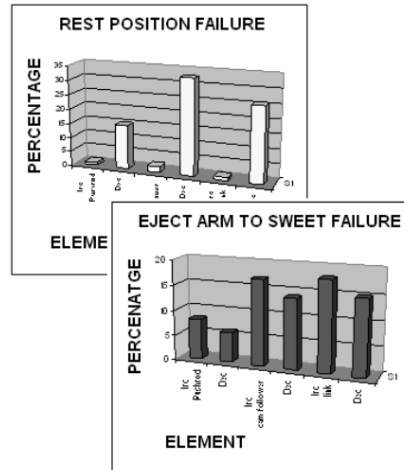

Fig. 10. Failure-mode plots

- the contact modes, only an elements decrease is permitted,
- the rest-position mode only allows small increases in element length, but it does allow large decreases.

With the graphical representations produced it became easy to understand the functional limits for the system. When modelling and recording the multiple instances of the system, it also became evident which elements were the most sensitive to change.

### 6 CONCLUSION

Generally, manufacturing machinery has been designed with the ability to process a range of products. Customer-focused manufacturing pressurizes manufacturers to produce ever-increasing families of products. So, what are the design implications, if the manufacturer has been asked to process a new or variant product? Does the machine have the inherent processing ability to manufacture the product? If not, what changes to the machine will give the ability to process the proposed product?

To address two questions, this paper has presented the limits of modelling methodology, where a constraint modelling environment is used within the environment, constraint optimization is employed for the structure and relationships of the system, and constraint checking is used to bound the model and its functionality against the given failure-mode constraints for the system and the processed product.

The specific outcomes of the methodology are as follows: It allows the opportunity for the engineer to investigate the redesign of a system to handle product variation. It offers the ability to represent failure-mode constraints into a constraint-based simulation/model. It permits a comprehensive sensitivity analysis to be performed on a design. It allows the functional envelope of a machine to be investigated and a range of visualization techniques can be employed to interrogate the analyzed design. The holistic constraint-based approach also offers the possibility for the engineer to optimize a design when resources are in conflict.

The current implementation has some limitations, i.e., at the construction stage the numerical techniques employed, and the struggle to handle large amounts of constraints and variables. At present the largest system modelled, a transmission system, had twenty-one variables and ten constraint rules. To overcome this, current work is concentrating on strategies for more complex systems. It is intended to employ the

information gain from the initial sensitivity analysis to produce a network strategy for this purpose. Also, the selection of a visual representation is important. In the example, a convex hull was employed. Due to the convex nature of the representation it does have the weakness of overestimating the design area. Because of this, the surface plots and failure-mode maps present the greatest potential. The approach described in this paper is currently being employed to investigate the capability of UK food-processing equipment to handle product variation.

### Acknowledgments

The research described in this paper has been carried out with the support of a Department of Environment, Food and Rural Affairs (DEFRA) research grant given as part of the Food Processing Faraday Knowledge Transfer Partnership (FPF-KTP). This support is gratefully acknowledged together with that of other collaborators.

### 7 REFERENCES

- [1] Hanlon, J. F., Kelsey, R. J and Forcini, H. E.(1998) Handbook of package engineering. *Technomic Publishing Company*.
- [2] Shigley, J. E and Uicker, J. J. (1995) Theory of machines and mechanisms. *McGraw-Hill International Editions*
- [3] Freudenstein. F. (1956).On the maximum and minimum velocities and accelerations in the four-link mechanisms. *Transactions of the ASME* 1956,78, 779.
- [4] Mable, H. H and Ocvirk, F. W(1965). Mechanisms and dynamic machinery. *J.Wiley and sons*. London.
- [5] Dwivedy, S. K and Eberhard, P., Dynamic analysis of flexible manipulators, a literature review *Mechanism and Machine Theory*, 41( 7),2006, 749-777
- [6] Woolfson, M. M and Pert, G. J. (1999), Introduction to computer simulation, *Oxford University Press*.
- [7] Gould, H. and Tobochnik, J.,(1996). An introduction to computer simulation methods: Applications to physical systems, *Addison-Wesley*.
- [8] PTC Inc., 2005 Pro/ENGINEER Solutions. <http://www.ptc.com/appserver/mkt/products/home.jsp?k=403>
- [9] Unigraphics NX3, <http://www.ugs.com/products/nx/> (accessed December 2006)
- [10] MSC Adam. <http://www.msccsoftware.com/products/adams.cfm> (accessed January 2007)
- [11] BOSS Quattro. SAMTECH. <http://www.samtech> (accessed January 2007)
- [12] NOESIS PLM. <http://www.noesissolutions.com/index.php?col=/products&doc=PLMO> (accessed January 2007)
- [13] CATIA V5, Project engineering optimizer. <http://www-306.ibm.com/software/applications/plm/catiav5/v5-latest.html> . (accessed January 2007)
- [14] Hicks. B.J., Medland.A.J., Mullineux.G. (2001) A constraint-based approach to the modelling and analysis of packaging machine. *Packaging technology and science* 14 (2001) 209-225.
- [15] Hicks. B.J., Medland.A.J and Mullinix. G. (2003) A constraint-based approach for optimum redesign of a packing operation. *Packaging technology and science* 16 (2003) 135-148.

- [16] Barton, P. I and Lee, C .K (2002) Modelling, simulation, sensitivity analysis and optimization of hybrid systems. *ACM Transactions on Modelling and Computer Simulation*, 12 (4) (2002), 256-289.
- [17] Hussu, A (1999) Analysis of dynamic systems by Bond-graphs. *Strojniški Vestnik-Journal of Mechanical Engineering* 45 (1999). (7-8), 278-286.
- [18] Pusey, J., Fattah, A., Agrawal, S. and Messina, E. (2003) Design and workspace analysis of a 6–6 cable-suspended parallel robot. *Procs IEEE/RSJ International Conference on Intelligent Robots and Systems*, Las Vegas, NV, 2003.
- [19] Curto, B., Moreno, V and Blanco, F. J., A general method for c-space evaluation and its application to articulated robots. *IEEE Transactions on Robotics and Automation*, 18(1):24–31, 2002
- [20] Kazerounian, S. M. K. and Gupta, K. C., (1982) Synthesis of position generating crank-rocker or drag-link mechanisms, *Mechanism and Machine Theory*, 17: 243-247, 1982.
- [21] Botturi, D., Fiorini, P and Martelli, S. (2003) A geometric method for robot workspace computation *Proceedings of ICAR03 - The 11th International Conference on Advanced Robotics* (2003).
- [22] Gosselin, C. M., Lavoie, E and Toutant, P *ASME 22nd Biennial Mechanisms Conference*, 45, Scottsdale, 1992, 323–328
- [23] Lin, V. C., Gossard, D. C. and Light, R. A. (1981), Variational geometry in computer-aided design, *Computer Graphics* 15(3), 171–177.
- [24] Merlet, J. P. (1995) Designing a parallel robot for a specific workspace. *Rapport de Recherche* 2527, INRIA, 1995.
- [25] Culley, S. J. (1999) Future issues for engineering design research. *UK Department of Trade and Industry (DTI) Workshop and Report*. Bath, 18, 19th Feb 1999.
- [26] Matthews, J., Singh, B., Mullineux, G., Medland, A.J., and Hicks, B.J. (2006). Constraint modelling as a means for understanding the limitations of a design and its performance. *Proc 6th International conference on Integrated design and Manufacturing in Mechanical Engineering*. (IDMME) 2006 Grenoble, France.
- [27] Lin, L and Chen, L. C. (2002) Constraints modelling in product design. *Journal of Engineering Design*, 2002, 13(3) 205-214.
- [28] O’Sullivan (2002) Constraint-aided conceptual design, *Professional Engineering Publication Limited*, London 2002.
- [29] Sandgren, E (1990) A multi-objective design tree approach for optimisation of mechanisms. *Mech Mach Theory*, 25(3), 257-272, 1990
- [30] Ding, L., Yue, Y., Ahmet, K., Jackson, M and Parkin, R. Global optimization of a feature-based sequence using GA and ANN techniques. *International Journal of Production Research*, 2005, 15(1) 3247-3272.
- [31] Márkus, A., Vánca, J., Kovács, A., (2002), Constraint-based process planning in sheet metal bending, *Annals of the CIRP*, 51/1: 425-428
- [32] Sadeh, M, and Fox, N, (1996) Variable and value ordering heuristics for job shop scheduling constraint satisfaction problem, *Artificial intelligence*, 86, 1-41 (1996)
- [33] Mullineux, G. (2001) Constraint resolution using optimization techniques. *Computers & Graphics*, 25, Issue 3, June 2001, Pages 483-492.
- [34] Anderl, R., and Mendgen, R., (1996). Modelling with constraints: theoretical foundations and application, *Computer-Aided Design* 28 (1996) 155-68.
- [35] Li, W. D., Ong, S. K. and Nee, A. Y. C., (2002) Hybrid genetic algorithm and simulated annealing approach for the optimization of process plans for prismatic parts. *International Journal of Production Research*, 40, 1899
- [36] Beck, H. A. (1992) Constraint monitoring in TOSCA. In *Working Papers of AAAI Spring Symposium: Practical Approaches in Planning and Scheduling*, Stanford, CA, March 1992.
- [37] Young, R., Greef, A and Ogrady, P., (1992) An artificial intelligence-based constraint network system for concurrent engineering. *International Journal of Production Research*. 30(7), 1715-1735.
- [38] Bowen, J and Bahler, D (1992) Frame, quantification, perspectives, and negotiation in constraint-networks for life-cycle engineering. *Artificial Intelligence in Engineering*, 7(4), 119-226.

- [39] Frank, P. M (1978) Introduction to systems sensitivity theory. *Academic Press*. New York.
- [40] Detcher, (2003) Constraint process, *Kaufmann Publishing*, USA
- [41] Leigh R.D., Medland A.J., Mullineux.G. and Potts I.R.B Model spaces and their use in mechanism simulation. Proceedings of the I. Mech. E part B *J.Eng. Manufact.* 203 (1989):167-74.
- [42] Gindy, N.N and Saad, S.S (1998) Flexibility and responsiveness of machining environments. *Integrated Manufacturing Systems*. (4) 218-227.
- [43] Corney, J. (1997) 3D Modelling with the ACIS Kernel and Toolkit. *Wiley*: Chichester.
- [44] Mullineux, G. (2006) Capability of food processing equipment to handle product variation. COFFEE Project report SID5 FT1106. *Department of Environment, Fisheries, and Rural Affairs (DEFRA)* July 2006.

Authors' Address:

Jason Matthews  
Baljinder Singh  
Prof. Dr. Glen Mullineux  
Prof. Dr. Tony Medland  
University of Bath  
Department of Mechanical Engineering  
Bath BA2 7AY, U. K.  
j.matthews2@bath.ac.uk  
b.singh@bath.ac.uk  
g.mullineux@bath.ac.uk  
a.j.medland@bath.ac.uk

Prejeto:  
Received: 2.5.2007

Sprejeto:  
Accepted: 27.6.2007

Odprto za diskusijo: 1 leto  
Open for discussion: 1 year