

OFF THE BEATEN TRACK: AN EXPLORATION OF BACH RECEPTION IN THE SLOVENIAN LANDS IN THE NINETEENTH CENTURY

TANJA KOVAČEVIĆ
Queen's University Belfast

Izvleček: *O prisotnosti glasbe J. S. Bacha na Slovenskem v prvi polovici 19. stoletja govorijo le sporadične omembe njegovega imena v takratnem periodičnem tisku. Razprava obravnava vlogo skladatelja Antona Foersterja in njegovih čeških korenin pri slovenskem odkrivanju Bacha. Osrednje zanimanje velja dvema rokopisoma, ki vsebujeta tudi prepise Bachovih skladb za glasbila s tipkami. Rokopisa sta skladatelja spremljala na njegovi poti iz Češke v Ljubljano, kjer se še danes hranita v Narodni in univerzitetni knjižnici.*

Ključne besede: *Anton Foerster, Johann Sebastian Bach, glasba v 19. stoletju na Slovenskem, Češka, glasbena recepcija, dela za glasbila s tipkami, preludij, fuga.*

Abstract: *Evidence of the presence of J. S. Bach in the Slovenian lands in the first half of the nineteenth century is limited to a few fleeting references to his name in contemporary periodicals. This article examines the role of the composer Anton Foerster and his Czech roots in the Slovenian Bach awakening through a detailed discussion of two manuscripts containing copies of Bach's keyboard works, which accompanied the composer on his journey from Bohemia to Ljubljana. The manuscripts are housed in the National and University Library, Ljubljana.*

Keywords: *Anton Foerster, Johann Sebastian Bach, nineteenth-century music in the Slovenian lands, Bohemia, reception of music, keyboard music, prelude, fugue.*

The reception of Bach's works is often rationalised in terms of its two distinct manifestations: that of tradition, on the one hand, and re-discovery or awakening,¹ on the other.

The research for this article was conducted in summer 2009 with the aid of a travel scholarship from the Arts and Humanities Research Council, to which I am deeply grateful. I also wish to acknowledge the help received from the staff of the National and University Library in Ljubljana, in particular from Mag. Alenka Bagarič and Mag. Zoran Krstulović. Finally, I would like to extend special thanks to the staff at the Scientific Research Centre of the Slovenian Academy of Sciences and Arts – Institute of Musicology, and particularly to its director, Dr Metoda Kokole, for allowing me access to material in its custody, and to Maruša Zupančič, on whose help I relied throughout my research trip.

¹ The last term was coined by Michael Kassler for the introduction or “discovery” of Bach's works in those parts of the world where no reference to Bach or his music is known to have been made during his lifetime, and in order to distinguish this from “revival” or “re-discovery”, which imply prior life. See Michael Kassler, Preliminary Note, *The English Bach Awakening*.

The two aspects have generally been allied with the dichotomy of the secular versus the spiritual Bach. The secular Bach, represented by his instrumental, and more particularly keyboard works, continued to subsist in a more or less uninterrupted tradition, even if this was initially restricted to his pupils and a narrow circle of connoisseurs. When the surge in editions of his works began in the 1800s, it was again the secular or, more precisely, the didactic Bach that took precedence. The spiritual Bach did not fare so well. His cantatas, despite their reputation as “Protestant church music in its purest and fullest bloom”,² as well as his Passions and motets, failed to establish a place (except in Leipzig) in the Protestant liturgy to which they were indigenous. They were also denied admission to the concert hall. Therefore, when they eventually secured their place in the performing repertory, it is appropriate to speak of their revival or (re-)discovery.

Although this dichotomy holds true for Germany, it might not necessarily apply to predominantly Catholic Central Europe.³ In many parts of this region, especially those countries off the beaten track of Western Bach scholars, the absence of any systematic study of Bach reception means that the picture has so far remained incomplete. However, cataloguing projects, particularly in smaller provincial and university libraries, together with technological advances exemplified by the digitisation of library resources (catalogues as well as entire collections), are creating new opportunities to study sources that have so far eluded Bach scholars.

In summer 2009, an exploration of the Music Collection of the National and University Library in Ljubljana unearthed two manuscripts containing copies of keyboard works by J. S. Bach: a collection of organ pieces (Music Collection, 2866/1955), with the title page “SAMMLUNG | verschiedener musikalischen | ORGELSTÜCKE. | für | Anton Förster | Stud. gymn.” (see Figure 1), and a short manuscript (Music Collection, 480/1979), the title page of which reads “1. Präludium und Fuge | über den Namen | BACH. | für das | Piano Forte oder die Orgel | von | Joh. Seb. Bach. | 2. Fuge von J. S. Bach. | Preis 30 fr. | A. M. Förster.” (see Figure 2). As is immediately evident from their title pages, the two manuscripts can be linked to Anton Foerster, a Slovenian composer of Czech origin. Both are of great interest to the study of Bach reception in the Slovenian lands.

Anton Foerster (1837–1926), the owner of these manuscripts, was born into a musical family in the Bohemian town of Osenice.⁴ He was first taught the organ by his father,

Knowledge of J. S. Bach and his Music in England 1750–1830, ed. Michael Kassler, Aldershot, Ashgate Publishing, 2004, p. xvii.

² Philipp Spitta, *Die Wiederbelebung protestantischer Kirchenmusik auf geschichtlicher Grundlage, Zur Musik. Sechzehn Aufsätze*, Berlin, Gebrüder Paetel, 1892, p. 54. All translations in this article are the author’s, unless otherwise indicated.

³ This article accepts the view of Central Europe as the area harbouring the cultural heritage of the former Habsburg Empire.

⁴ Biographical information on Anton Foerster in this article is derived from the following sources: Fran Mohorič, Glasbenik. Anton Foerster [manuscript], *Gradivo o A. Foersterju*, National and University Library, Ljubljana, Music Collection, 27/56, mapa 2; Fran Rákuša, *Slovensko petje v preteklih dobah*, Ljubljana, Samozaložba, 1890, pp. 144–146; Vladimír Foerster, Anton Foerster. Življenjepis na črt, *Dom in svet* 17 (1904), pp. 216–223; František Jirášek, Obrana reformy církevní hudby, *Cyril* 32 (1905), p. 3; *Foersterjev zbornik*, ed. Edo Škulj, Ljubljana,

Figure 1
Sammlung – title page (National and University Library, Ljubljana, Music Collection, 2866/1955; with permission).

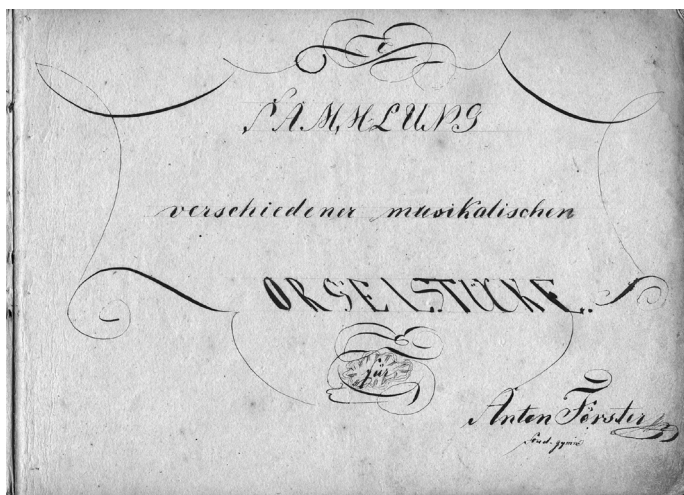
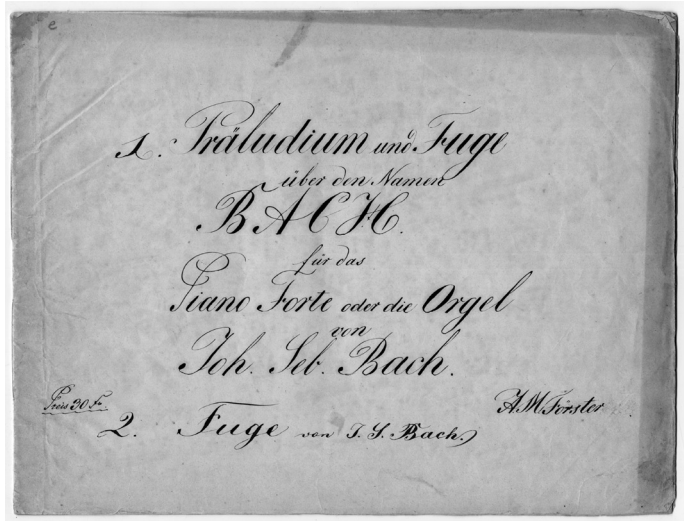

Figure 2
Präludium und Fuge – title page (National and University Library, Ljubljana, Music Collection, 480/1979; with permission).



violin by a local musician, and piano by his sister. Between 1850 and 1854 he attended the lower gymnasium in Mladá Boleslav and then continued his education at the upper gymnasium in České Budějovice, where he also studied singing with Josef Eil. It is said that Anton's uncle, a priest in the nearby Cistercian monastery of Vyšší Brod (Ger. Hohenfurt) supported him throughout his gymnasium days, and that a sense of gratitude for this support, which the monastery continued after the uncle's death, prompted Anton

Družina, 1998; Stanko Premrl, †Anton Foerster, *Cerkveni glasbenik* 49 (1926), pp. 57–59; Fran Ferjančič, Anton Foerster kot človek, *Cerkveni glasbenik* 50 (1927), pp. 6–10, 38–42, 92–95; Gracian Černušák, Förster, Antonín, *Československý hudební slovník* 1, Prague, Státní hudební vydavatelství, 1963, pp. 341–342.

to join the Cistercian order in Vyšší Brod upon matriculation in 1858.⁵ He served there as organist, succeeding his brother Josef, who had left the monastery the year before to become organ teacher at the Prague Organ School. After eleven months Anton moved to Prague, where he studied law until 1863, while also studying composition and piano. In 1865 he became cathedral organist and *regens chori* in the Croatian town of Senj. He moved to Carniola (the central part of today's Slovenia) in 1867, and remained there for the rest of his life. In Ljubljana he worked as choirmaster of the music society Narodna čitalnica (Reading Room) and conductor of the Dramatično društvo (Dramatic Society), then as *regens chori* and organist at the cathedral. He became a passionate supporter of the Caecilian movement and in 1877, under the auspices of the Caecilian Society, founded the Ljubljana Organ School. He also edited the music supplement of society's periodical *Cerkveni glasbenik* (*The Church Musician*). In addition to his own compositions, he wrote a number of theoretical works, including *Nauk o harmoniji, generalbasu in kontrapunktu* (1881), a treatise on harmony and counterpoint, and the four-volume piano manual *Teoretično-praktična klavirska šola* (1886–1890).

The *Sammlung* of the National and University Library in Ljubljana (Music Collection, 2866/1955)

The first of Anton Foerster's manuscripts, his *Sammlung*, consists of several types of laid paper, varying in colour from yellowy-brown to darker greyish-brown, with some wove paper towards the back. It measures 31 x 22 cm (trimmed) and has no discernible watermarks. Numerous pencil annotations, additions and corrections throughout the manuscript, as well as candle-wax stains, detached leaves and torn edges attest to its (heavy) practical use. The progressive level of difficulty within its musical content, compiled over a number of years, suggests that the *Sammlung* had an educational purpose. Titles such as "Zum Agnus" ("At the Agnus") or "Zur Wandlung" ("At the Consecration") permit a further connection with the Catholic liturgy, which is consistent with the biographical accounts portraying Anton as a practising church organist from an early age. Evidence that the *Sammlung* was used for liturgical purposes can also be found in the grouping of pieces according to liturgical function; for example, most of the pieces found at the start are preludes, while the pastoral pieces, intended for use during the Christmas season, are grouped together and, as they are not required for everyday services, placed at the end of the *Sammlung*. Their dating confirms they were used during the festive season of 1858/9. The *Alleluja Paschale*, another occasional piece (for use at Easter), has similarly been placed towards the back of the manuscript, preceding the pastoral pieces. Page markers with key indications served to enable the organist to find a piece in the desired key quickly.⁶

According to an inscription inside the front cover, the manuscript was later owned by Ana Romer-Lavrič (1869–1955?), who graduated from the Ljubljana Organ School in

⁵ Ferjančič, op. cit., p. 94.

⁶ The only two tabs complete with key indications – "B" and "Es" – are found on f. 13^v. However, numerous remnants of tabs that have been torn off can be discerned throughout the manuscript.

TABLE 1
Sammlung – contents

Folio	Contents / Description	Original dating	Scribe	Phase
0 ^r	Pasted onto front cover		–	(I) II
0 ^v	Inside cover with inscription: <i>Anna Romer-Lavrič / 1919</i>		A. Lavrič	(I) II
1 ^r	Title page: <i>SAMMLUNG verschiedener musikalischen ORGELSTÜCKE. für Anton Förster Stud. Gymn.</i>		Foerster	I
1 ^v	Unused		–	I
2 ^r –5 ^r	<i>Præludium N^o 1. Allegretto. Paleček Jos. aus Neustupov. r. In Böhmen geboren 1819. 2. Andante. Smetana Franz geboren 1819 zu Rokytan in Böhmen. N^o 3. Allegretto Uksa Franz geb. 1823 zu Zásnuk in Böhmen 4. Fuge. Allegro moderato. Holuška Johann geb. 1819 zu Rokytan in Böhmen.</i>		A	I
5 ^v –7 ^v	<i>5. Mässig. C. F. Pitsch, Director der Prager [Organis]ten-Schule. †1858 6. Nicht allzu gedehnt. 7. Ziemlich bewegt. 8. Mehr bewegt. 9. Mässig langsam; mit durchgreifenden Stimmen.</i>		A	I
8 ^r	Pasted systems: <i>Fuga von Albrechtsberger. /: Wegweiser für d. Klavirschüler im 1. Stad. v. Knorr./</i>		Foerster	II
8 ^v	<i>10. b) Zur Wandl. Andantino 10. c.) Zur Wandlung. 10. d. Zum Agnus u. z: Wandlung. Larghetto.</i>		Foerster	II
9 ^v –13 ^v	No. 11–40		B	II
14 ^r	<i>Prælud. 41. von F. H. Brixi. And^{te} mol^{te}. 42. Andante von Ans. Hüttenbrenner. Während [?] d. h. Walz</i>		Foerster	III
14 ^v –15 ^r	<i>Fuge von Adam. Adagio</i> <i>Hohenfurt. Vis. B. M. V. 3/7/59</i>		Foerster	(III) IV
15 ^v –16 ^v	<i>Fughetta. F. M. Barth.</i> <i>Senj 3/10/66</i> <i>Fuga. S. Bach (Ex Dis in E transpos.)</i> <i>7/12/66</i>		Foerster	(III) V
17 ^r –18 ^v	<i>Alleluja Paschale. Fuge mit zwey Subjecten von C. F. Pitsch. Allegro*</i>		B	IV
19 ^r	Larghetto. Dumpfe Stimen		Foerster ?	IV
19 ^v	Unused		–	IV
20 ^r	<i>1. Pastoral – Præludium v. Robert Führer.*</i>		B	IV
20 ^v –21 ^v	<i>2. Maestoso. Pastoral-Præludium von Jos. Drechsler.*</i>			IV
21 ^v	Pasted systems: <i>≡de.</i> [continued from f. 22 ^r] <i>Hfirt. 30/12/58</i>		Foerster	IV
22 ^r	<i>3. Prælud. pastor: Andante quasi Allegretto. 4. Præludium pastorale. Moderato. Sechs Pastoral-Prælud (2. f.) von Rob. Führer.</i>		B	(III) IV
23 ^r –23 ^v	<i>5. Præludium passtorale. Con moto. Sechs Pastoral-Prælud. (2. f.) von Robert Führer.</i> <i>Hfirt. 31/12/58</i>		Foerster	(III) IV
24 ^r	<i>6. Zur Wandlung u. zum Agnus. Larghetto Sechs Pastoral-Prælud. (2. f.) von Rob. Führer.*</i>		B	IV
24 ^v	<i>7. Fuga pastor. von C. F. Pitsch.*</i> <i>Bdws. 15/10/57</i>		Foerster	IV
25 ^r –25 ^v	<i>8. Moderato. 9. Zur Wandlung. Adagio Sechs Pastoral-Prælud. (2. f.) von Rob. Führer</i> <i>Hfirt. 1/1/59</i>		Foerster	IV
26 ^r –28 ^r	Unused		–	III
28 ^v	Pasted onto back cover		–	III

*) Pieces that were copied before they were bound into the manuscript.

1905 and held organ positions at the churches of St Joseph and Križanke in Ljubljana. She also deputised at Ljubljana Cathedral in Anton Foerster's absence.⁷

Parts of the manuscript have deteriorated so severely that a complete and conclusive reconstruction is not possible. Nevertheless, the differences in the paper used and its varying degrees of deterioration, the clear separation of gatherings and the presence or absence of earlier binding marks, together with the locations and dating provided for certain pieces, as well as biographical information on Anton Foerster, allow us to determine roughly at what stage a particular gathering was incorporated into the manuscript.

Initially the manuscript probably consisted of a ternio containing the title page with an unused verso, followed by pieces for organ notated on two systems and numbered 1–7. A binio was added to complete the seventh piece and copy the remaining three (see Ph a s e I in Table 1 and Figure 3). The tenth piece, which presumably occupied the lowest three systems of f. 8^r and the first system of f. 8^v, was pasted over and replaced with new content. The pasted paper is thicker and yellower than that of the original gathering, which, together with the difference in rastration and the change in the handwriting, suggests that the pasting occurred when the collection was combined with another manuscript in the next phase of compilation. It is likely that the last two folios of the added binio were originally unused, and that in the next phase the last folio was folded around the ternio, while the other was simply excised.

Indications of authorship above each piece have made it possible to trace the contents of this section back to two publications, both of which can be linked to the Verein der Kunstfreunde für Kirchenmusik in Böhmen.⁸ The first four pieces belong to a collection titled *Praeludien und Fugen für die Orgel. Aus den Compositions-Versuchen der Zöglinge der vom Vereine der Kunstfreunde für Kirchenmusik in Böhmen gegründeten prager Organisten-Schule Herausgegeben von dem leitenden Ausschusse dieses Vereines. Ites Heft*.⁹ According to its foreword, the collection represents the most successful compositional endeavours by the most talented of the Prague Organ School students. The second group of pieces originated from the collection *Zwanzig kurze und leicht ausführbare Präludien für die Orgel für alle Bedürfnisse des kirchlichen Ritus mit besonderer Rücksicht auf seine Schüler*,¹⁰ by Carl Franz Pitsch (1786–1858). Having served at the Prague Organ School from 1840 as organ teacher, Pitsch became the School's director in 1842 and remained in this position until his death. Under his long leadership, the School produced many

⁷ [Anon], 40 let v službi sv. Cecilije, *Slovenec* 69 (1941), 302a, p. 3.

⁸ The institution was established in 1827 by a group of church music enthusiasts who felt a strong urge to take action against the declining standards of church music and organ playing in the Czech lands. To this end, the Verein supplied to the provinces and to poorer churches music that it deemed to be of good quality, adequate, and at the same time practicable for the liturgy, at the lowest possible cost or free of charge. In 1830 it established the Prague Organ School. For more information on the roles of the Verein, see Tanja Kovačević, *Bach Reception in Prague: An 1845 Performance of the Second Kyrie from the B minor Mass, Understanding Bach* 5 (2010), pp. 23–48.

⁹ Published by Hoffman in Prague (1845).

¹⁰ Published by Hoffman in Prague (1847).

Phase I (~1850)

Osenice

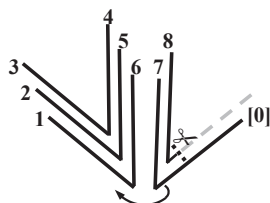

Phase II (~1854)

České Budějovice

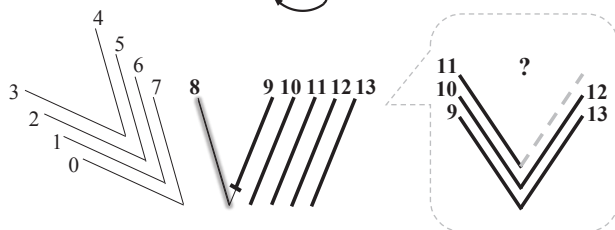

Phase III (1857)

České Budějovice

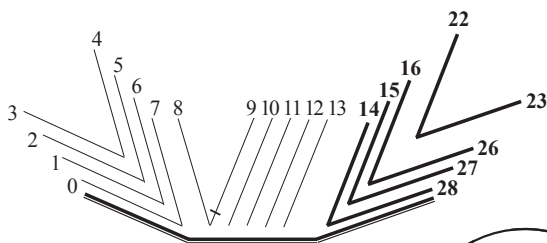

Phase IV (1859)

Vyšší Brod

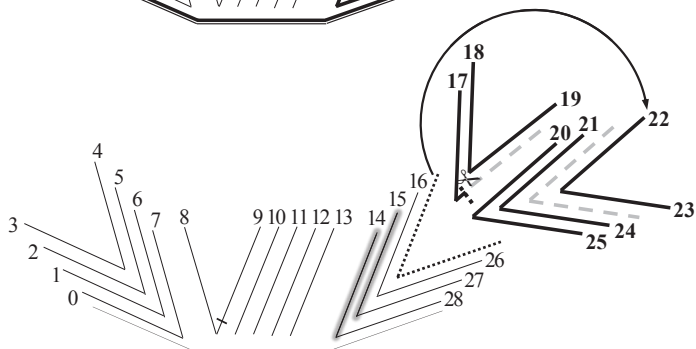

Phase V (1866)

Senj

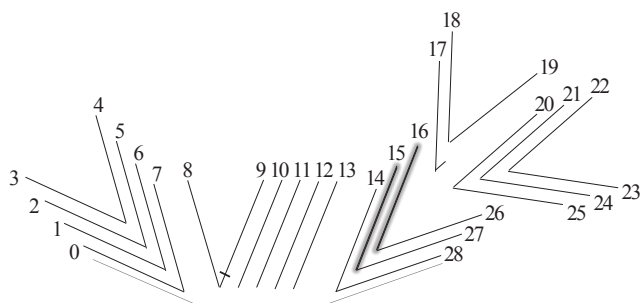

Figure 3

Sammlung – reconstruction.

eminent musicians, including Anton's brother Josef (1833–1907), who graduated in 1852 as the best student of his generation and in 1857 himself became organ teacher there.¹¹

The known date of the second publication – 1847 – provides a possible *terminus post quem* for the manuscript's inception. The indication “Stud. gymne” on the original title page enables us to narrow down its earliest possible date of origin further to 1850, when the twelve-year-old Anton commenced his studies at the lower gymnasium in Mladá Boleslav. The handwriting of this part of the collection is unlikely to be the young Anton's; it is relatively mature and uniform, and in many respects it resembles the handwriting of Anton's father Josef (senior).¹² Anton, as can be seen from the next phase of compilation, is still “searching” for his identity as copyist; he is experimenting with different forms of time signature and several clef shapes, and his attempts to imitate his models are at times ungainly (see Figure 4).

The preposition “für” on the title page might imply that the original *Sammlung* was given to Anton by someone else, perhaps another family member, at the decisive point in his life when he left the family home to continue his education.

The change of handwriting from f. 9 onwards corresponds with the first of the middle stages of the *Sammlung*'s compilation, when several other manuscripts were bound in to form a volume together with the pre-existing section. Phase II corresponds with ff. 9–13 and contains pieces numbered 11–40. The extremely poor condition of this part of the *Sammlung* makes it very difficult to ascertain its original structure. The first folio of what may once have been a ternio is joined on to the last folio of the previous section and is followed by four loose folios. The original numbering, which started at 1, was amended to start at 11, presumably by Anton himself, continuing the sequence he had initiated in phase I. Changes to the numbering are discernible also on f. 10 (Nos. 20–26), but not on f. 11 (Nos. [27]–29), which, if the original sequence started at 1, implies that a number of pieces preceding No. 27, possibly occupying a single folio, have been removed. It is also possible that Anton was given the individual folios of an already dismembered gathering. If this was indeed the case, his binding would not have been as effective, and the leaves would have torn off more easily, which could explain the extraordinary level of deterioration of this section.

At the intersection preceding the new manuscript, Anton himself copied a basic two-part fugue by Johann Georg Albrechtsberger (1736–1809), taken from Julius Knorr's *Wegweiser für den Klavierschüler im ersten Stadium. Eine Sammlung gewählter Klavierstücke in möglichst rechter Progression, nebst mechanischen Uebungen*.¹³ The imprecise and often incorrect vertical alignment of notes hints that Anton had not yet

¹¹ Josef Srb Debrnov, *Varhanická škola v Praze, Dalibor 1* (1879), pp. [171], 180 and [187].

¹² It differs, however, in a number of crucial elements, such as the design of the crotchet and of the quaver rest, and the manner of placing flats in the key signature, which in the *Sammlung* are frequently placed below the corresponding pitch. The comparison was based on the autograph of Joseph Förster's *Pisně české*, with a note on the flyleaf by his famous grandson Josef Bohuslav, which reads: “Rukopis mého dědečka Josefa Förstera, učitele v Oseních v Mladé Boleslavi. Jos. B. Foerster.” The manuscript is housed in the Muzeum české hudby in Prague (shelfmark XXVI E 159).

¹³ Published by Breitkopf & Härtel in Leipzig [1853].



Figure 4

Anton Foerster's early handwriting, f. 8^v (National and University Library, Ljubljana, Music Collection, 2866/1955; with permission).

gained much experience in copying music. The pieces numbered 10b–d, also added by him, remain unidentified.

The new section (f. 9) starts with a set of preludes from an unknown source, written for organ on two systems in a texture that implies minimal use of the pedals. These are followed by a selection of preludes from *XX Praeludien (einfach und leicht) zum Gebrauche beim öffentlichen Gottesdienste* by Liberatus Geppert (1815–1881).¹⁴ The very neat and steady handwriting (see Figure 5), which is not Anton's, implies the involvement of an experienced scribe (hereafter, scribe B), possibly someone in a position of authority. Anton, albeit rather unsuccessfully, tried to imitate his clef-forms on f. 8, as he copied the new content into the unused and newly pasted systems at the back of his old manuscript when he joined the two collections. The guiding principle in the ordering of the pieces appears to have been the gradual introduction of sharps and flats. The progressive level of difficulty, which becomes apparent when the musical content of this phase is compared with that of

¹⁴ Published by K. F. Müller in Vienna (1847). On account of the unavailability of this edition at the time of writing, a modern edition based on the first edition was consulted; see Liberatus Geppert, *Zwanzig Präludien für Orgel*, ed. Wolfram Hader, Frankfurt, Laurentius-Musikverlag, 2007. No. 29 of the *Sammlung*, attributed to Geppert, does not appear in this edition.

the later ones, copied by the same hand, could point to a systematic musical education, on which Anton could have embarked in České Budějovice, where he attended the upper gymnasium from 1854. The pieces may have been given to him by his teacher. Another possibility is that he received organ tuition at the nearby monastery of Vyšší Brod, where his brother Josef worked as organist. The handwriting, however, is not Josef's, and our information on the priest uncle who supported Anton during this time is insufficient to permit further speculation. The identity of scribe B therefore remains unknown.

In Phase III Anton added a new ternio (ff. 14–16/26–28), which may initially have been blank, and on which he probably intended to copy new pieces. Although the verso of f. 28 is pasted on to the back of the cardboard cover, it is difficult to establish whether the cover was added only during this phase or was already present.

The first two pieces, copied by Anton himself, continue the numbering of the previous section and are the only two pieces added during this phase; ff. 14^v–15^v were filled at a later stage, while the rest of the gathering remains unused. No. 41 is a Prelude by František Brixi (1732–1771), published in the second volume of the collection *Fugen und Praeludien von älteren vaterländischen Compositoren*,¹⁵ another publication of the Verein der Kunstfreunde für Kirchenmusik in Böhmen brought out to further its aim of raising the standard of organ playing throughout the country. The second piece is a short Andante by Anselm Hüttenbrenner (1794–1868), the model for which could not be determined. At the end of the page appears the inscription “Bdws” (short for Budweis, the German name for České Budějovice), together with the date “15/10/57” and the initials “AF”. Anton's handwriting in this phase, towards the end of his upper gymnasium education, has become neater, more mature and consistent, his quaver rests now adopting the shape of a 7 (as opposed to his earlier S-shaped quaver rests).

The presence of earlier binding marks on ff. 22–23 suggests that this unio was likewise bound into the *Sammlung* during phase III. It initially contained two Pastoral Preludes from *Sechs Pastoral-Präludien (2. Folge)*¹⁶ by Robert Führer (1807–1861). The inscription “Sechs Pastoral-Prælud. von Rob. Führer (2.f.)”, entered above both preludes, is Anton's own later addition, while the musical text is in the hand of scribe B. The preludes are longer and technically more demanding than those of phase II.

Of all the parts of the *Sammlung*, Phase IV has the most complex genesis. Two separate manuscripts from Anton's time in České Budějovice were added to the collection at this point, as suggested by the absence of signs of previous binding from them. The dating and place indication “Hfrt”, which Anton supplied when he re-copied some of the pieces while reordering one of the gatherings to bind it into his manuscript, provide reliable evidence that the two gatherings were added to the *Sammlung* between 30 December 1858 and 1 January 1859. At that time Anton was a novice at Vyšší Brod. Before inserting the new gatherings, he copied a fugue into the unused ff. 14–15 and wrote “Hohenfurt. Vis. B. M. V.” with the date “3/7/89” after the final barline. As this is described only as “Fuge von Adam”, it has not been possible to identify the composer and trace the work's origin.¹⁷

¹⁵ Published by Marco Berra, H. J. Enders und Gottlieb Haase Söhne in Prague (1832).

¹⁶ Published by J. Hoffmanns W^{ve} in Prague [before 1859].

¹⁷ It may belong to a set of fugues by J. G. Adam, advertised as a new publication by Breitkopf &



Figure 5

The handwriting of scribe B, f. 9^r (National and University Library, Ljubljana, Music Collection, 2866/1955; with permission).

The first manuscript bound into the volume was a ternio (ff. 20–25), containing four more pastoral preludes from the above-mentioned collection by Robert Führer, another from his *Sechs leicht ausführbare Pastoral-Präludien für die Orgel*, Op. 3,¹⁸ and a pastoral prelude by Joseph Drechsler (1782–1852) from an unidentified source. These are once again in the hand of scribe B. On one of the three unused pages at the back of the gathering (f. 24^v) Anton himself copied a pastoral fugue based on the traditional Czech Christmas carol “Narodil se Kristus pán” (“Christ the Lord was born”). Its title in the *Sammlung* reads “Fuga pastor. von C. F. Pitsch.,” but it is in fact Fugue VIII from the collection *Acht Toccaten und Fugen für die Orgel*¹⁹ by Josef Ferdinand Norbert Seger (1716–1782). The extent of the divergence between this and the published version suggests that the *Sammlung* version was copied from a manuscript, and the misattribution could have occurred at any point during its transmission. According to the inscription “Bdws 15/10/57 A. F” at the

Härtel: “Für die Orgel. Adam, J. G., 6 Fugen. 9^{tes} Werk”, in *Allgemeine musikalische Zeitung* 31 (1829), Intelligenz-Blatt 9, col. [34]. No surviving copy of the edition is known.

¹⁸ Published by Jacob Fischer in Prague (1830).

¹⁹ Published by Breitkopf in Leipzig [1793].

end of Seger's fugue, Anton obtained the manuscript some time before this date, while he was still in České Budějovice.

It was probably a desire to keep the pastoral pieces together that made him detach ff. 22–23, added in the previous phase, and combine them with the new gathering. The dating suggests that he performed the pieces during the festive season of 1858/9. Their association with the Christmas season, which renders them unsuitable for everyday use, justifies their placement at the back of the *Sammlung*. However, the new ternio could not simply be inserted into the old unio, since the insertion would then split the piece occupying ff. 22^v–23^r. Inserting the old unio into the new ternio would have been equally problematic, since the pieces written on the ternio, copied by scribe B, were originally numbered 1–6, so that the insertion would have disrupted the sequence. Inserting the unio after f. 20 was similarly out of the question, as it would have resulted in a break-up of the piece on ff. 20^r–21^v. Since there was some unused space at the back of both gatherings, Anton decided to remove the inner part of the ternio, containing the preludes Nos. 3–5, and replace it with the old unio, designating the two preludes it contained as Nos. 3–4. He then recopied the pieces he removed in the unused systems on f. 23 and the spare f. 25. Thus what had originally been Prelude No. 3 became No. 5, while Nos. 4–5 became Nos. 8–9.

The second manuscript bound into the *Sammlung* in phase IV is a binio, from which the last, presumably unused, folio has been removed. This gathering, currently occupying ff. 17–19, precedes the group of pastoral pieces at the back of the *Sammlung* and contains another occasional piece, Pitsch's *Alleluja Paschale. Fuge mit zwei Subjecten für die Orgel*.²⁰

In Phase V no further gatherings were bound into the *Sammlung*. Only two pieces were copied on the unused systems of f. 15^v, continuing on f. 16. The first, described as “Fughetta. F. M. Barth.”, is a keyboard arrangement of one of Mendelssohn's responses to the Commandments “Lord, have mercy upon us” (MWV B 27), published in *Album für Gesang mit Original-Beiträgen von Chelard, Kalliwoda, [...], herausgeg. von R. Hirsch. Ister Jahrg.*²¹ The work was originally composed for a mixed choir. Anton copied it on 3 October 1866, during his time as organist of Senj Cathedral. The last piece added to the *Sammlung*, dated “7/12/66” and likewise copied in Senj, was the Fugue in D-sharp minor from Bach's *Well-Tempered Clavier* II (BWV 877/2). Its title reads “Fuga. S. Bach (Ex Dis in E transpos.)”. The different rastration of f. 16^v implies that Anton used a previously blank page when he needed more space to copy out the remainder of Bach's fugue.

Bach's Fugue BWV 877/2

Bach's Fugue in D-sharp minor has been transposed to E minor, possibly because of the unsuitability of the key. Since the *Sammlung* was used during church services, a

²⁰ Published by Marco Berra in Prague (1835). The countersubject of this fugue is remarkably close to the subject of the Bach's Fugue in F-sharp major in the *Well-Tempered Clavier* II (BWV 882/2).

²¹ Published by Bösenberg in Leipzig (1841). I wish to thank Dr Hiromi Hoshino for her help with identifying this piece.

piece in D-sharp minor would not have fitted in well with the keys commonly used for congregational singing. However, this fugue is usually transposed to D minor,²² which is also more straightforward notationally.²³ Since it is impossible to determine whether the transposition was Anton's own or originated from his model, one can only speculate on the reasons for the atypical choice of key. While the limitations of the instrument on which the fugue was intended to be played could have been an issue of consideration, the choice of key could equally have been based on personal preference.

An examination of the text indicates that the fugue was copied either from Czerny's 1837 edition or from another manuscript or edition based on it, as suggested by the unique reading of the bass part in bar 21, beats 1–2 (i.e. ♭-♮ instead of ♭). The replacement of Bach's *Tierce de Picardie*, retained in Czerny's edition, with a minor-key ending may be found in the edition of the *Well-Tempered Clavier* published [c. 1831] by the Prague publisher Marco Berra, but the resemblance ends there. The substitution may have been an independent decision on the part of the copyist, in order to have the piece end in the key in which it began.

Präludium und Fuge of the National and University Library in Ljubljana (Music Collection, 480/1979)

The second of Anton Foerster's manuscripts from the collection of the National and University Library in Ljubljana comprises only a ternio and measures 32,5 x 24,5 cm. There are no discernible watermarks. Originally the manuscript contained only the Prelude and Fugue for keyboard on the name BACH in B-flat major (BWV 898); the authenticity of this work is today regarded as doubtful.²⁴ The second piece, Bach's Fugue in C minor from the *Well-Tempered Clavier* I (BWV 847/2), appears to be a later addition.

²² The same fugue, transposed to D minor and arranged for strings, is found in Mozart's autograph of K. 405. For further details see Warren Kirkendale, KV 405: Ein unveröffentlichtes Mozart-Autograph, *Mozart Jahrbuch* 1962–1963 (1964), pp. 140–155; Yo Tomita, Bachowski przebudzenie Mozarta – studium kontekstu, *Przegląd Muzykologiczny* 7 (2009), p. 195. The fugue also appears as Fuga V in C. F. Horn, *A Set of Twelve Fugues, Composed for the Organ by Sebastian Bach, Arranged as Quartettos, for Two Violins, Tenor & Bass, with the Addition of A Piano Forte part, or Thorough. Bass*, London, 1807. See Yo Tomita, The Dawn of the English Bach Awakening Manifested in Sources of the “48”, *The English Bach Awakening*, op. cit., pp. 98 and 133.

²³ Another, albeit less obvious suggestion, for which I am obliged to Prof. Michael Talbot, is that Foerster's model could have been notated in E-flat minor, but described as “Dis”, as was often the case in conservative eighteenth-century nomenclature. Transposition into E minor, if one wanted to play in a key with fewer flats, would thus have been the simplest and most logical choice. On the other hand, in the absence of any manuscripts or published editions that transmit this fugue in E-flat minor, the proposed theory cannot be fully substantiated. I thank Prof Yo Tomita for the information on extant sources of the *Well-Tempered Clavier* II, shared in private communication.

²⁴ See Ulrich Bartels and Frieder Rempp, *Werke zweifelhafter Echtheit für Tasteninstrumente, Johann Sebastian Bach. Neue Ausgabe Sämtlicher Werke. Kritischer Bericht v/12*, Kassel [...], Bärenreiter, 2006, pp. 223–226.



Figure 6

First edition of BWV 898, title page (Bach-Archiv Leipzig: Rara II, 329; with permission).

The title page (see Figure 2), on which traces of original pencil lines can be discerned only under the title of the first piece, confirms that the two works were not copied in close succession. The two titles also appear to be in different handwritings, as evident in the word “Fuge” and Bach’s name. For reasons that remain unclear, the title of BWV 898 on the title page and the initial set of clefs with the key and time signatures are in the hand of scribe B. The original text below the mark of ownership “A. M. Förster”, which may have been the name of the previous owner or of the person who commenced the copying, appears to have been scratched out. The initial “A” may originally have been the letter “J”. The note of the price on the manuscript probably reads “30 Xr” (*Kreuzer*). Since there is no known edition with a price stated in *Kreuzer* from which the title page could have been copied, we must assume that either the manuscript was originally intended for sale (which never materialised), or that it was copied from another manuscript sold at that price.

Since the remainder of the musical text is in the hand of Anton Foerster, a comparison with his handwriting as encountered at different stages of the *Sammlung*’s compilation, taking account of the conclusions regarding the dating of its parts, allows to date the first piece to around 1854 (or slightly later), when he was using S-shaped quaver rests and endeavouring to imitate the clefs he came across in his models.

The number of imprints and surviving printed or manuscript copies, as well as the various arrangements and transcriptions of the work, attest to its popularity in the

nineteenth century. The first edition of the work, published in c. 1819, carries a similarly formulated title: *Praeludium und Fuge über den Namen BACH für das Pianoforte oder die Orgel von Joh. Seb. Bach. Chez Breitkopf & Härtel à Leipsic. Pr. 10 Ngr* (see Figure 6). A text-critical analysis has produced ample evidence that Anton's copy was based on the Breitkopf edition; correspondences in the distribution of notes between the two staves, beaming, accidentals, ties, slurs, rests, and other instructions (dynamics, pedal, trills) all point to this.

The second piece, BWV 847/2, was added on the unused systems at the end of the manuscript (f. 5) and bears the inscription "Bdws. 23/12/1857. A. F.". Its handwriting is more condensed, probably due to the limited space available, and the characteristic 7-shaped quaver rest matches Anton's more mature handwriting found in the parts of the *Sammlung* copied in 1857. Among the known editions of the *Well-Tempered Clavier* published before 1857, Czerny's 1837 edition seems to be the closest to Anton's text. There are substantial correspondences between the two sources in the application of articulation and expression marks, and the bass doubling from bar 25. The differences, fewer in number, are limited to the layout of the score, including the distribution of notes between the hands (as in bars 5–6, 15 and 20), and the application of cautionary accidentals, articulation and expression marks (especially prominent in the coda). The distorted, or even corrupt, fugal texture in bars 5–6, where the material from the upper system was moved to the lower (possibly to facilitate sight-reading), makes it likely that Anton's model was a manuscript in which nearly all the notational features had been finalised, rather than the Czerny edition.

Conclusion

As the advertisements of Leopold Paternolli and Ignaz von Kleinmayr, two of Ljubljana's main music sellers from the period preceding Anton's arrival, demonstrate, the public relished musical confectionery in the form of waltzes, polkas, gallops and arrangements of favourite operatic numbers. A typical advertisement would read:

[...] Czerny, XIV Eccossaises brillantes, pour le Piano-Forte. Oeuvre 174. 45 kr. | Lachner, Favorit=Walzer mit Trio für das Piano-Forte, über die beliebten Thema der Oper: "die weiße Frau." Wien bei Pannauer, 36 kr. | Berbiguier, Trente six petits Duos, pour deux Flûtes. Op. 72. 2. Partie 1 fl. | Bodstein, Variationen für die Guitarre, Op. 9. Braunschweig, 30 kr. | Jansa, Sechs leichte Duetten für zwei Violinen, Cah. 5. Wien 30 kr | Höfner, Gräzer Redout=Deutsche für zwei Violinen und Baß, Graz, 30 kr, [...].²⁵

The serene and sublime character of Bach's music and its technical demands do not appear consonant with the musical tastes that pervaded secular and church music alike;

²⁵ [Anon], Kunst=, Musik= und literarische Anzeige. Bei Leopold Paternolli, *Intelligenzblatt zur Laibacher Zeitung* 21 (1830), p. 82. Similar advertisements appeared in the *Laibacher Zeitung* during the first half of the nineteenth century from two of Ljubljana's main music sellers, Leopold Paternolli and Ignaz von Kleinmayr.

even Masses were “composed according to the latest taste, and arranged in such a way that they can be performed without difficulty, to good effect”.²⁶ It is therefore hardly surprising that evidence of Bach’s presence on the Slovenian territory during the first half of the nineteenth century is limited to a few fleeting references to his name in periodicals. One such instance is an essay on “absent-mindedness” from the *Laibacher Wochenblatt* of 1804, which recounts an anecdote about the eldest of Bach’s sons, the absent-minded Wilhelm Friedemann. The reference to Johann Sebastian appears in the section’s introduction:

The Bach family, which has earned undying laurels for the fame of German music, gives us in the three sons of the great Sebastian Bach men as singular in the domain of the art as they differed profoundly from one another in character.²⁷

A similar situation in Foerster’s native Bohemia triggered much resentment of the decadence that had crept into churches and concert halls,²⁸ a resentment that was repeatedly voiced in Czech periodicals²⁹ and led to concerted efforts to rescue music from such deterioration. However, a lingering complacency, mixed with a lack of support and a bout of ill fortune that stifled the isolated rescue attempts,³⁰ seems to have taken hold of the Slovenian lands. The first significant steps towards improvement came with the birth of the Caecilian movement, the initial aspirations of which were voiced by Kamilo Mašek in his resounding critique of church music,³¹ as well as in a series of articles in his journal *Cäcilia*. Upon his arrival in Ljubljana, Anton Foerster joined in the initiatives of the Caecilians.

Although the movement promoted Renaissance vocal music and Gregorian chant as its ideals, its efforts to raise the standard of music education created fertile ground for a gradual increase of interest in Bach’s music. Anton’s note, published alongside Bach’s Fugue in D major from the *Well-Tempered Clavier* II (BWV 874/2) in the supplement of the *Cerkveni glasbenik*, is particularly illustrative in this respect:

Caecilians, do not shy away from this fugue, composed by the most renowned master

²⁶ Musikalien Anzeige, *Intelligenzblatt zur Laibacher Zeitung* 23 (1814), p. 2

²⁷ [Anon], Der Zerstreute, *Laibacher Wochenblatt* 30 (1804), p. [1].

²⁸ The abandonment of elaborate polyphony in favour of simpler textures and more modest technical demands, especially in sacred music, led to what the Bohemian musical elite at the beginning of the nineteenth century saw as a marked deterioration in artistic standards.

²⁹ One of the most vehement outcries against declining musical standards, which condemns “the insignificance of the purposes which the inferior art of our time pursues” and “ungrateful posterity’s obfuscating fog of oblivion”, through which audiences are deprived of “a wealth of the most daring, noble and moving compositions”, appears in [Anon], Ueber die musikalische Akademie am 22. Dezember, *Bohemia* 9 (1836), 155, p. [4].

³⁰ One such attempt was the music school of the Ljubljana Cathedral, which closed a mere three years after its establishment. The Public Music School, established in 1816, suffered a run of incompetent teachers and the untimely death of the competent ones. See Cvetko Budkovič, *Razvoj glasbenoga šolstva na Slovenskem I. Od začetka 19. stoletja do nastanka konservatorija*, Ljubljana, Znanstveni inštitut Filozofske fakultete, 1992.

³¹ Kamilo Mašek, O cerkvenom petji in orglanji po deželi, *Novice* 15 (1857) [the article was published in seven parts]. In issue 52 (p. 207) Mašek lists Bach among the composers whose works he recommends for study by organists.

of strict music, which we impart to diligent organists as an example. Pay attention to the fingering in both hands as well as to the changes between feet in the pedal (d=right, s=left foot). This is a difficult task, but the effort is repaid.³²

One cannot help but hear in these words an echo of an earlier commentary by Pitsch, which accompanied another of Bach's fugues (BWV 546/2) in his *Museum für Orgelspieler*:

May it be it clear to every learner of the organ what great effect one can achieve through the use of the pedals. What is an organ without pedals? What is a prelude without a meaty bass? All the grandeur of the magnificent instrument is quite lost without this artistic device. The above fugue by Seb. Bach, in which the pedal carries the fifth part, is appropriate for advanced organ study, for which this collection was essentially intended to pave the way. To the diligent student it will demonstrate how the pedal reinforces the fullness of harmony independently of the manual bass and elevates the majestic instrument to the height of splendour and impressiveness. Without such studies, transcending mere mediocrity is unthinkable. Thus proceed without exasperation towards more difficult tasks.³³

Incidentally, Pitsch's version of this fugue was transposed from C minor to D minor, written on two systems (with a pedal obbligato instruction beneath the system) instead of in the original three-system notation and shortened by removing a large portion of the text (bb. 79–139). The text in b. 140 of this version was altered in order to connect the two sections. Smolka speculates that the fugue needed to be shortened in order to conform to Catholic liturgy, and that the transposition was dictated by the difference in tuning of Czech organs.³⁴

In Anton's *Sammlung* we possess another example showing how Bach's music – particularly his keyboard oeuvre, which was originally recommended as study material – eventually became part of the Catholic church organist's repertoire. The specific liturgical constraints often necessitated modifications to the original material, such as cuts, transpositions and even recomposition, as is also the case here. However, the picture that has started to emerge with the discovery of these new sources is that the dichotomy described in the introduction to this article ceased to apply when the secular, rather than the spiritual, Bach found a niche within the Catholic liturgy. Although Kretzschmar's statement in the closing report of the Bach-Gesellschaft edition concerned the cantatas, passions and motets, it seems more than appropriate to state that “the main part of Bach's art, as must be stressed again and again, is intended for the church”.³⁵

³² Anton Foerster, Naše priloge, *Cerkveni glasbenik* 9 (1886), p. 88; Bach's fugue was published in the supplement to this issue.

³³ *Museum für Orgelspieler. Sammlung gediegener und effectvoller Orgel-Compositionen älterer und neuerer Zeit III*, ed. Carl Franz Pitsch, Prague, Marco Berra, 1834, p. 69.

³⁴ Jaroslav Smolka, Problém autorství českých varhanních skladeb 18. století v Pitschově *Museum für Orgelspieler*, *Hudební věda* 14 (1977), pp. 242–257.

³⁵ Hermann Kretzschmar, Die Bach-Gesellschaft. Bericht im Auftrage des Direktoriums, *Johann Sebastian Bach's Werke* 46, Leipzig, Bach-Gesellschaft, 1899, p. lxi.

NA ROBU ZNANEGA: RAZISKAVE RECEPCIJE BACHOVE GLASBE
NA SLOVENSKEM V 19. STOLETJU

Povzetek

V razpravah o recepciji del Johanna Sebastiana Bacha se pogosto pojavljata dva pristopa, obravnava v okviru tradicije na eni strani in odkrivanja oz. ponovnega odkrivanja po drugi strani. Bachova posvetna dela, predvsem tista za glasbila s tipkami, imajo bolj ali manj neprekinjeno tradicijo rabe, predvsem v obliki učnega gradiva, medtem ko so njegova duhovna dela najprej zatonila v pozabo, da so nato v začetku 19. stoletja ponovno krenila na pot oživitve. Ta dvojnost, ki sicer drži za Nemčijo, pa morda ne drži tudi za pretežno katoliške predele srednje Evrope, kjer sicer še niso bile opravljene sistematične raziskave Bachove recepcije. Projekti katalogizacij glasbe in nove tehnološke možnosti pa so vendarle ustvarile nove možnosti raziskav virov, ki so se raziskovalcem Bacha doslej izmuznili.

Pričujoč članek se osredotoča na dva doslej neraziskana rokopisa, ki ju hrani Narodna in univerzitetna knjižnica v Ljubljani in vsebujeta Bachove skladbe za glasbila s tipkami. Oba sta bila nekoč last slovenskega skladatelja češkega rodu Antonu Foersterju. Pregled njune vsebine in fizičnih značilnosti (struktura, papir, raster, vezava in sam rokopis) ter vseh časovnih in krajevnih beležk, ki se ju tičejo, skupaj z omembami v obstoječi literaturi o izvirnem lastniku, je omogočil datacijo obeh rokopisov, ki naj bi nastala v času Foersterjevega šolanja na Češkem. Ugotovljene so bile tudi okoliščine, ki so botrovale vključitvi treh Bachovih del za glasbila s tipkami (BWV 877/2, BWV 898 in BWV 847/2) v obravnavana rokopisa, njihova besedilno-kritična analiza pa razkriva možne vzore. Rokopisa potrjujeta močan vpliv, ki ga je imelo društvo prijateljev umetnosti za cerkveno glasbo (izv. Verein der Kunstfreunde für Kirchenmusik) na Češkem in praška orgelska šola. Obe ustanovi sta imeli pomembno vlogo pri dviganju standardov orgelske igre in cerkvene glasbe na Češkem kot tudi popularizaciji Bachovih del. Preko Antona Foersterja so tu vplivi dosegli tudi slovenske etnično ozemlje.

Na koncu avtorica ugotavlja, kako so Bachova posvetna dela, preko svoje namembnosti študijske rabe dejansko našla nišo v katoliških glasbenih potrebah in tako prešla iz posvetnega v duhovni svet.

