

SOCRATIC LECTURES PART II

8TH INTERNATIONAL SYMPOSIUM, LJUBLJANA, 21. JANUARY 2023

PEER REVIEWED PROCEEDINGS

EDITED BY: VERONIKA KRALJ-IGLIČ AND ANNA ROMOLO

FACULTY OF HEALTH SCIENCES, UNIVERSITY OF LJUBLJANA

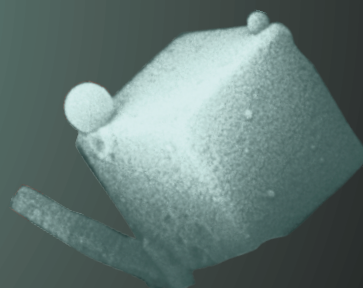
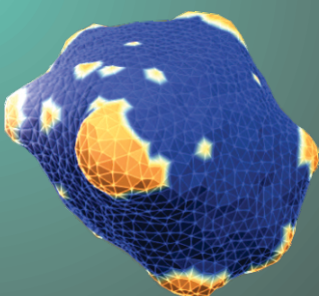
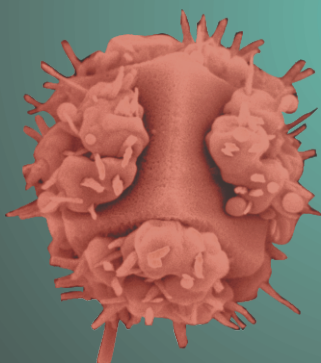
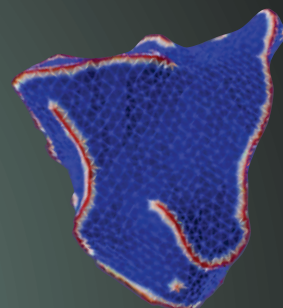
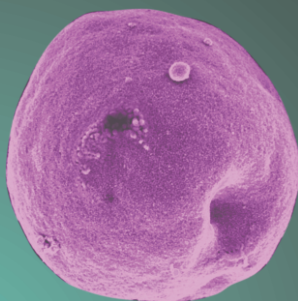
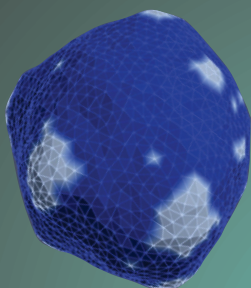
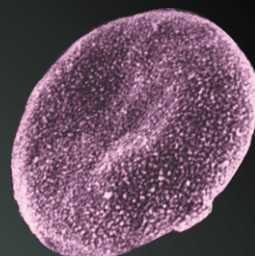
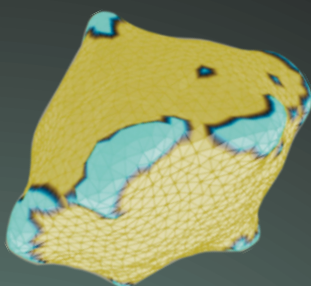
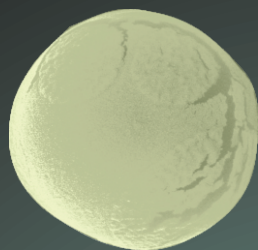

Socratic lectures

8th International Minisymposium, Part II, Ljubljana, January 21, 2023

Peer Reviewed Proceedings

Edited by Prof. Veronika Kralj-Iglič, Ph.D. and Anna Romolo

Reviewers: Yelena Istileulova, Vesna Spasovski

Published by: University of Ljubljana Press

For the publisher: Gregor Majdič, The Rector

Issued by: University of Ljubljana, Faculty of Health Sciences

For the issuer: Andrej Starc, The Dean

Design: Anna Romolo

Gallery Saint Champs: Mitja Drab, Vid Šuštar, Marguerite de Saint Champs

Image on the front page: Marguerite de Saint Champs

First digital edition.

Publication is available online in PDF format at: https://www.zf.uni-lj.si/images/stories/datoteke/Zalozba/Sokraska_8_II.pdf

DOI: 10.55295/PSL.2023.II

Publication is free of charge.

Ljubljana, 2023

This work is available under a Creative Commons Attribution 4.0 International



Kataložni zapis o publikaciji (CIP) pripravili v

Narodni in univerzitetni knjižnici v Ljubljani

COBISS.SI-ID 150528771

ISBN 978-961-297-119-9 (PDF)



The members of the Organizing Committee of 8th Socratic Lectures: Angelo Beletić, Matej Daniel, Tatia Dolidze, Drago Dolinar, Vladimira Erjavec, Haque M, Aleš Igljč, Yelena Istileulova, Boštjan Kocjančič, Veronika Kralj-Igljč, Blaž Mavčič, Gabriella Pocsfalvi, Anita Prelovšek, Anna Romolo, Gitta Schloser, Renata Vauhnik.

Program of the Socratic Symposium January 21, 2023, 10:00 – 13:00(Ljubljana time)

10:00 – 10:45 **Plenary lecture: Sergej Tomić; Belgrade, Serbia:** Immune response in COVID-19: Biomarkers and therapeutic targets

Section 1: Human Medicine organized and moderated by **Boštjan Kocjančič** and **Yelena Istileulova**

11:00 - 11:15 **David Malidze, Rishu Bansal; Tbilisi, Georgia:** Cardiac arrhythmias in patients with myocarditis in the post-COVID period

11:15 - 11:30 **Marika Zhamutashvili, Rishu Bansal, Shweta Tilante, Nino Badridze, Ekaterina Dolmazashvili, Natia Jojua, Tinatin Gognadze; Tbilisi, Georgia:** Diagnostic and prognostic analysis of serological and biochemical markers in patients with COVID-19: A retrospective study

11:30 - 11:45 **Eka Kokhraidze, Zaza Avaliani, Maia Zhamutashvili, Nino Gabashvili; Tbilisi, Georgia:** Observation on tuberculosis preventive treatment in Georgia

11:45 - 12:00 **Špela Tadel Kocjančič; Ljubljana, Slovenia:** Neuroprognosis in determination of brain death after reanimation

12:00 - 12:15 **Boštjan Kocjančič; Ljubljana, Slovenia:** Use of tranexamic acid in orthopaedic surgery

12:15 - 12:30 **Darja Pestotnik; Ljubljana, Slovenia:** Effects of aerobic exercise with blood flow restriction on cardiorespiratory system with emphasis on respiratory parameters in healthy young men

12:30 - 12:45 **Sara Bitenc Zore; Ljubljana, Slovenia:** Narrow-band imaging - Clinical application in otorhinolaryngology

12:45 - 13:00 **Yelena Istileulova; Ljubljana, Slovenia:** International accreditation and rankings

Section 2: Veterinary Medicine organized and moderated by **Vladimira Erjavec** and **Angelo Beletić**

11:00 - 11:30 **Angelo Beletić; Zagreb, Croatia:** Serum, saliva, and liver proteome indices associated with platelet biology during inflammatory conditions in the different animal species

11:30 - 11:45 **Vida Eraghi; Zagreb, Croatia:** Vaccine development against paratuberculosis

11:45 - 12:00 **Barbara Lukanc, Vladimira Erjavec; Ljubljana, Slovenia:** Portosystemic shunts in cats

12:00 - 12:15 **Levan Tsitskishvili, Levan Makaradze, Tengiz Kurashvili, Nino Milashvili, Zura Makaradze, Ekaterina Sanaia; Tbilisi, Georgia:** Canine sirofilariasis in the South Caucasus and its pathomorphology

12:15 - 12:30 **Naida Kapo; Sarajevo, Bosnia:** Phenotypic and genotypic analysis of anthelmintic resistance

12:30 - 12:45 **Paul Kail; Canada:** Successful second intention healing of a large skin wound in a cat's cheek using Manuka honey



12:45 - 13:00 **Manca Novak; Ljubljana, Slovenia:** Tracheal stents in dogs

Section 3: Musculo-Skeletal Health organized and moderated by **Renata Vauhnik**

11:00 - 11:30 **Arcangelo Russo; Enna, Italy:** Untreated associated lesions as predictors of failure of anterior cruciate ligaments

11:30 - 12:00 **Duško Spasovski; Belgrade, Serbia:** Recent results in treatment with mesenchymal stem cells

12:00 - 12:15 **Maja Petrič; Ljubljana, Slovenia:** New approach in trunk muscle endurance testing

12:15 - 12:30 **Sergeja Bec, Ljubljana, Slovenia:** Effects of capacitive and resistive electric transfer therapy on skin temperature

12:30 - 12:45 **Fabio Valenti; Ljubljana, Slovenia:** Short- and long-term relaxation effects of soft tissue structures of the posterior myofascial line in patients with non-specific low back pain

12:45 - 13:00 **Jana Hočevar; Ljubljana, Slovenia:** Arthrogenic muscle inhibition and ankle instability

Section 4 : Prosthetics organized and moderated by **Blaž Mavčič** and **Drago Dolinar**

11:00 - 11:14 **Blaž Mavčič; Ljubljana, Slovenia:** Periprosthetic fractures of proximal femur

11:15 - 11:30 **Borut Pompe; Ljubljana, Slovenia:** Total knee prosthesis in hemophiliacs

11:30 - 11:45 **Doroteja Okorn, Puh U; Ljubljana, Slovenia:** Knee injury and osteoarthritis outcome score (KOOS) in total knee replacement: Systematic review of measurement properties

11:45 - 12:00 **Oskar Zupanc; Ljubljana, Slovenia:** Advances in shoulder endoprosthetics

12:00 - 12:15 **Drago Dolinar; Ljubljana, Slovenia:** Mechanisms of endoprosthesis wear and loosening

12:15 - 12:30 **Aljaž Merčun; Ljubljana, Slovenia:** Case of revision of Copf hip endoprosthesis

12:30 - 12:45 **Sophio Samkharadze, Marika Zurmukhtashvili, Eka Kokhraidze, Elene Kharashvili, Sesili Beriashvili; Tbilisi, Georgia:** Availability of dental services for medical students in Georgia

12:45 - 13:00 **Sophio Samkharadze, Marika Zurmukhtashvili, Eka Kokhraidze, Elene Kharashvili, Sesili Beriashvili; Tbilisi, Georgia:** Assessment of oral health status among medical students in Georgia

Section 5: Physics: organized and moderated by **Aleš Iglič** and **Matej Daniel**

11:00 - 11:30 **Samo Kralj, Luka Mesarec, Aleš Iglič; Maribor and Ljubljana, Slovenia:** Topological excitations in nematic liquid crystals and particle physics

11:30 - 11:50 **Szymon Starzonek, Sylwester Rzoska, Aleš Iglič; Ljubljana, Slovenia and Warsaw, Poland:** Dielectric study of induced phase transitions in lyotropic liquid crystals

11:50 - 12:10 **Mitja Drab, Katarina Mendova, Matej Daniel; Prague, Czech Republic and Ljubljana, Slovenia:** Observation of a second-order thermoporetic effect in lipid vesicle populations depends on phase transition temperature



- 12:10 - 12:30 **Luka Mesarec, Aleš Iglič, Samo Kralj; Ljubljana, Slovenia and Maribor, Slovenia:** Altering the position of topological defects in nematic shells
- 12:30 - 12:50 **Matej Gartner, Matej Perovnik, Martin Horvat; Ljubljana, Slovenia:** Bioelectricity – from ion transfer to anatomy formation

Section 6 : Nanostructurome organized and moderated by **Gabriella Pocsfalvi** and **Gitta Schloser**

- 11:00 - 11:15 **Gabriella Pocsfalvi; Naples, Italy:** Proteomics of extracellular vesicles
- 11:15 - 11:30 **Gitta Schlosser; Budapest, Hungary:** Advances in mass spectrometry for characterization of biological samples
- 11:30 - 11:45 **MD. Mozzammel Haque; Gono, Bangladesh:** Protein misfolding and aggregation
- 11:45 - 12:00 **Maneea Mabrouk AbdElkhalk Mubarak; Alexandria, Egypt:** Green EV. The production of extracellular vesicles using plant cell suspension culture
- 12:00 - 12:15 **Shota Nebieridze, Maia Kereselidze, Maia Beruashvili, Vazha Kvachrelishvili, Marine Matskepladze; Tbilisi, Georgia:** Clinical and hematological examination of cattle affected by theileriosis
- 12:15 - 12:30 **Matevž Arko, Anna Romolo; Ljubljana, Slovenia:** Characterization of plasma preparations by interferometric light microscopy and flow cytometry
- 12:30 - 12:45 **Kaja Troha; Ljubljana, Slovenia:** Storage of plasma rich with extracellular vesicles and platelets
- 12:45 - 13:00 **Matej Hočevar; Ljubljana, Slovenia:** Imaging of plasma by scanning electron microscopy

Section 7 : Universal Science, Art and Education organized and moderated by **Anita Prelovšek** and **Tatia Dolidze**

- 11:00 - 11:15 **Tatia Dolidze, Ioseb Kelenjeridze, Levan Meskhoradze; Tbilisi, Georgia:** Modern and innovative teaching methods of legal education
- 11:15 - 11:30 **Natia Jojua, Tinatin Gognadze, Tsisana Giorgadze, Ana Lolishvili; Tbilisi, Georgia:** Implementation of modern technologies in Medical Education
- 11:30 - 11:45 **Petra Pergar; Ljubljana, Slovenia:** Evaluation of circular management with water in towns with models and visualization of data
- 11:45 - 12:00 **Ema Kocjančič, Špela Tadel Kocjančič; Ljubljana, Slovenia:** Clinic Charitee, Berlin, Germany
- 12:00 - 12:15 **Roberta Schmid, Giancarlo Lamberti; Naples, Italy:** Beethoven in Heiligenstadt in the museum dedicated to him: the Man and the Artist
- 12:15 - 12:30 **Nelfi Paliska; Koper, Slovenia:** Amour, sors pour jamais – Armide by Gluck
- 12:30 - 12:45 **Ana Ligia Mastruzzo; Buenos Aires, Argentina:** The Mesoamerican sound heritage in present Argentine music for flute



Editorial

Dear colleagues and friends,

The International Symposium 8th Socratic lectures marked 15th anniversary of the meetings that started in 2008 with a single lecture by prof. Bernd Engelmann from Munich on blood microparticles (now called extracellular vesicles or extracellular particles or small cellular particles). The lecture took place at the lecturing room of the Department of Orthopaedic Surgery, University Medical Centre Ljubljana. At that time we could not imagine that 15 years later the event would evolve into an online meeting covering 7 sections (Human Medicine, Veterinary Medicine, Musculo - Skeletal Health, Prosthetics, Physics, Nanostructure and Crossroads of Science, Medicine, Art and Education) with about 100 lecture contributions and about 130 attendants of the symposium from 14 countries. This year, symposium included 56 undergraduate students from University of Ljubljana, Faculty of Health Sciences and Faculty of Medicine, 10 students from Doctoral School of University of Ljubljana and 18 members of organizing committee. We were amply supported by the colleagues from European University in Tbilisi, Georgia to which we are especially thankful to dr. Yelena Istileulova who mediated our collaboration. As we were happy to receive more than 40 contributions to the Proceedings of 8th Socratic Lectures, they will be composed into two parts, each of them having its own gallery. The Gallery "Sacred Fields" of the Part II is exposing 24 images of extracellular vesicles taken by scanning electron microscope at Abo Akademi University, Abo Finland by Vid Šuštar and calculated by minimization of membrane free energy by Mitja Drab. Artwork on these images and on front page was performed by Marguerite de Saint Champs. Our special thanks are to the artists who contribute essentially to the contents of the Proceedings.

Looking back, we can evidence an enormous gift of all those who came and donated. It means a proof that science and education have a meaning. In the name of the students who have been a spiritus movens of the Socratic lectures, and in my name, with gratitude, and hope to see you again,

Veronika Kralj-Iglic



CONTENTS

TEXTS

1. Malidze David, Bansal Rishu, Noniashvili Marina, JoJua Natia, Gognadze Tinatin, Ahmad Mreisat: Cardiac arrhythmias in patients with myocarditis in the Post-COVID-19 period.....1
2. Bansal Rishu, Zhamutashvili Marika, Tilante Shweta, Kipiani Nina, Badridze Nino, Dolmazashvili Ekaterine, Jojua Natia, Gognadze Tinatin: Diagnostic and prognostic analysis of serological and bio-chemical markers in patients with COVID-19: A retrospective study.....10
3. Troha Kaja, Vozel Domen, Battelino Saba: Storage of platelet-rich products.....15
4. Samkharadze Sophio, Zurmukhtashvili Marika, Kokhraidze Eka, Kharashvili Elene, Beriashvili Sesili: Assessment of oral health status among medical students in Georgia.....23
5. Samkharadze Sophio, Zurmukhtashvili Marika, Kokhraidze Eka, Kharashvili Elene, Beriashvili Sesili: Availability of dental services for medical students in Georgia.....29
6. Vladimira Erjavec, Barbara Lukanc: Portosystemic shunts in cats.....34
7. Kail Paul AC: Successful second intention healing of a large skin wound in a cat's cheek using Manuka honey.....41
8. Tsitskishvili Levan, Makaradze Levan, Kurashvili Tengiz, Milashvili Nino, Makaradze Zurab, Sanaia Ekaterina: Canine dirofilariasis in the South Caucasus and its pathomorphology46
9. Arko Matevž, Schlosser Gitta, Iglíč Aleš, Kruljc Peter, Nemeč Svete Alenka, Erjavec Vladimira, Kralj-Iglíč Veronika: Erythrocyte sedimentation in tubes for preparation of human, equine and canine plasma rich with platelets and extracellular vesicles.....53
10. Bec Sergeja, Weber Daša, Vauhnik Renata: Effects of capacitive and resistive electric transfer therapy on skin temperature - Literature review.....59
11. Penič Samo, Iglíč Aleš, Kralj-Iglíč Veronika: Electronic blood sedimentation monitoring with microcontrol-ler and linear CCD sensor.....67
12. Romolo Anna, Hočevár Matej, Iglíč Aleš, Griessler Bulc Tjaša, Kralj-Iglíč Veronika: Short term effect of plant hybridosomes on growth of *Phae-odactylum Tricornutum* culture74
13. Starzonek Szymon, Rzoska Sylwester, Iglíč Aleš : Dielectric study of induced phase transitions in lyotropic liquid crystals.....88
14. Prešern Andreja: Pathogen-plant interactions in plant membrane perforation.....98
15. Adamek Maksimiljan: Molecular grammar of RNA-binding protein interactions in formation and function of ribonucleoprotein complexes110
16. Bedina Zavec Apolonija: Extracellular vesicles for cosmetic applications..... 116



17.	Smerkolj Nik, Jeran Marko: Testing market efficiency in emerging markets' stock indices with runs tests.....	125
18.	Rzoska Agata Angelika, Drozd-Rzoska Aleksandra: The Story about one island and four cities. The Socio-Economic soft matter model - Based report.....	131
19.	Mastruzzo Ana Ligia: The Mesoamerican sound heritage in current argentinian music for flute.....	149
20.	Prevlovšek Anita: . Music in the life and literary works of Anton Pavlovich Chekhov.....	157
21.	Istileulova Yelena: Accreditation and rankings of Universities: Theory of global accreditation in the world of (Dis)order.....	168
22.	Kocjančič Ema, Travnik Tina, Kocjančič Boštjan: Interdisciplinary cooperation and education at Charité Uni-versitätsmedizin Berlin.....	178
23.	Schmid Roberta, Lamberti Giancarlo: "Beethoven in Heiligenstadt in the museum dedicated to him: the Man and the Artist".....	187
24.	Štrbac Aleksandra, Ambrožič Janja, Barlič Leja, Berce Nika, Bolte Nuša, Čoralić Ajla, Cingere Matija, Černigoj Aljaž, Dedić Amra, Djura Meta, Fuks Tia, Georgijev Blaž, Gosarič Urban, Gril Mirjam, Jakše Maruška, Japelj Neža, Jesenko Petra, Keber Pia, Klančnik Klara, Kne Uma, Kozjek Zala, Krk Loti, Kuselj Klara, Lalović Zoja, Lazić Leon, Lesjak Sara, Lešnik Jon, Majcen Sandra, Malič Sara, Marenče Manca, Maselj Petja, Mesić Alen, Mihelič Ajda, Miholič Anja, Miljkovic Emina, Modrijan Kim, Moškrič Lara, Oprin Anamarija, Ozmec Maja, Pikec Tinkara, Požgaj Svit, Prelec Tijana, Primožič Sara, Pristov Alja, Puškar Raisa, Sok Nika, Sovič Maruša, Škof Anej, Šuštarich Valentina, Topolovec Nika, Udovč Šink Živa, Vaš Taris, Zupančič Urša, Kralj-Iglič Veronika: Students' reflections on 8th Socratic Lectures.....	193
25.	Kokhreidze Eka, Avaliani Zaza, Gabashvili Nino, Zamutashvili Maia: Observation on tuberculosis preventive treatment in Georgia.....	198

POSTERS

1.	Bonin Luka, Korošec Hafner Jan, Oblak Tina, Ponikvar-Svet Maja, Barrios Rigoberto Francisco, Kralj-Iglič Veronika, Oder Martina, Jeran Marko: Impact of the preparation Process of European spruce (<i>Picea abies</i>) homogenates and common marigold (<i>Calendula officinalis</i>) isolate on total phenolic content	P1
2.	Kovačič Pšenica: Decoding feline emotional-motivational systems, emotions and behaviour in marketing:	P2
3.	Krulic Peter: Thermography as an aid in the performance testing of Lipizzan horse.....	P3
4.	Pavlovič Anja, Jearn Marko, Ponikvar-Svet Maja: Comparison of the Folin-Ciocalteu and 4-aminoantipyrine spectrophotometric methods for the determination of total phenolic content in tea infusions.....	P4
5.	Spruk Gregor, Anderluh Gregor, Crnković Ana: Incorporation of non canonical amino Acid into poreforming proteins using genetic code expansion.....	P5
6.	Tramšek Melita, Gruden Evelin, Jeran Marko: Interdisciplinary informal education Approach for sustainable knowledge amango primary and secondary school students via a scientific research institution.....	P6



Invited lecture/Review

Cardiac Arrhythmias in Patients with Myocarditis in the Post-COVID-19 Period

Malidze David¹, Bansal Rishu¹, Noniashvili Marina², JoJua Natia¹, Gognadze Tinatin¹, Ahmad Mreizat¹

¹ European University, Tbilisi, Georgia

² Tbilisi State Medical University

* Correspondence: David Malidze; malidze.david@eu.edu.ge

Citation: Malidze D, Bansal R, Noniashvili M, JoJua N, Gognadze T, Mreizat A. Cardiac Arrhythmias in Patients with Myocarditis in the Post-Covid-19 Period. Proceedings of Socratic Lectures. 2023, 8; 1-8. <https://doi.org/10.55295/PSL.2023.II1>

Publisher's Note: UL ZF stays neutral with regard to jurisdictional claims in published maps and institutional affiliations.



Copyright: © 2023 by the authors. Submitted for possible open access publication under the terms and conditions of the Creative Commons Attribution (CC BY) license (<https://creativecommons.org/licenses/by/4.0/>).

Abstract:

To date, several cardiotropic viruses have been implicated as causes of myocarditis. The most detected are parvovirus B19, and human herpes virus 6. Severe Acute Respiratory Syndrome Coronavirus 2 (SARS-CoV-2) are the respiratory viruses that have recently triggered the unprecedented pandemic process. The involvement and impact of these viruses in viral cardiovascular disease are under study. Despite extensive research into the pathological mechanisms of viral infections of the cardiovascular system, our knowledge regarding their treatment and management is still incomplete. A condition caused by post-COVID-19 myocarditis seems to have distinct inflammatory characteristics. Many kinds of arrhythmias may occur in patients with post-COVID-19 myocarditis and result in arrhythmogenic cardio-myopathy and sudden cardiac death. Sometimes arrhythmia can be the first and only symptom of myocarditis. However, compared to the other clinical presentations, arrhythmic myocarditis has been poorly described in the literature. The increased risk of arrhythmias in patients with a post-COVID-19 period is most likely a consequence of systemic inflammation and diseases, not just a direct consequence of the viral infection. A decrease in heart rate variability can contribute to electrical instability of the myocardium and the occurrence of arrhythmias. Cardiac magnetic resonance imaging and endomyocardial biopsy are the most useful tests for myocarditis. However, different from the other clinical presentations, arrhythmic myocarditis requires specific diagnostic, prognostic, and therapeutic considerations. This review aims to critically summarize the state of the art on myocarditis presenting with arrhythmias in terms of epidemiology, aetiology, diagnosis, prognosis, and treatment.

Keywords: Post-COVID-19; SARS-CoV-2; Myocarditis; Arrhythmias; Ferroptosis; Vaccination



1. Introduction

Since December 2019, the novel coronavirus SARS-CoV-2 has spread rapidly throughout China and still keeps the world in suspense. Cardiovascular complications with myocarditis and embolism due to COVID-19 have been reported. SARS-CoV-2 genome detection in the heart muscle has not been demonstrated so far, and the underlying pathophysiological mechanisms remain to be investigated.

Myocarditis is described as an inflammation of the heart muscle, resulting in damage in the absence of ischemia. It has been suggested that viruses are an important aetiology of myocarditis with a wide range of causes including but not limited to adenovirus, parvovirus B19, Epstein-Barr virus and cytomegalovirus (Siddiqi et al., 2021). Now the latest evidence suggests that SARS-CoV-2 virus may also be an important infectious agent for myocarditis. The proposed pathophysiology of viral myocarditis is a combination of direct cellular damage and immune-mediated cell death. Many kinds of arrhythmias may occur in patients with post-COVID-19 myocarditis and develop into arrhythmogenic cardiomyopathy and sudden cardiac death (Chung et al., 2021).

2. SARS-CoV-2 and Myocarditis

COVID-19 can lead to subacute and chronic myocarditis of varying severity. Post-COVID myocarditis is characterized by prolonged persistence of coronavirus in combination with high immune activity (high titres of antinuclear antibody), which should be considered as the main mechanisms of its long-term course (Ali et al., 2022).

The incidence of COVID-19-induced myocarditis is not well established. A study reported that myocardial injury occurred in 20% to 30% of hospitalized patients with COVID-19 infection, and cardio-vascular complications contributed to approximately 40% of all COVID-19-related deaths (Ismayl et al., 2022).

During March 2020–January 2021, patients with COVID-19 had nearly 16 times the risk for myocarditis compared with patients who did not have COVID-19, and risk varied by sex and age (Boehmer et al., 2021).

In a study conducted in Germany (Escher et al., 2020), endomyocardial biopsies were performed on 104 patients with acute myocarditis and heart failure who had been infected with COVID-19. The study showed that SARS-CoV-2, as detected by PCR, was present in only 5% of patients. However, genomes of other viruses were detected in 85% of cases, the most frequently detected was Parvovirus B 19 (Escher et al., 2020). The authors suggested that SARS-CoV-2 in many cases could be the trigger that led to the development of inflammatory damage of the myocardium (Escher et al., 2020).

Later, in 2021, a review was published that included more than 1,000 patients with suspected acute myocarditis and heart failure, and SARS-CoV-2 genome was present in only 1% of the patients. The virus that appeared in 2019 is not a new cardiotropic virus. Thus, two large studies showed that in the case of myocarditis there were two viruses - one that was latent and the other that was replicating. Myocarditis can occur under the simultaneous influence of two or more different infections, when one of them, as a rule, creates conditions and the other is the direct cause of damage. It is not known whether clinical symptoms of cardiac histopathology differentiate patients with multiple infections or whether they have a worse prognosis compared to patients with only one type of virus in the heart. It should be noted that 90% of people have a latent virus in their blood at the end of their lives (Schultheiss et al., 2021).

In another study in Germany (Tanacli et al., 2021), Cardiac Magnetic Resonance (CMR) and EndoMyocardial Biopsy (EMB) findings revealed that a SARS CoV-2 infection showed a variable cardiac involvement. Patients with more symptoms and those with higher clinical care demands were more likely to exhibit impaired myocardial function and developed chronic inflammation more often compared to patients with “classic” acute myocarditis during the acute and convalescent phases (Tschöpe et al). This study highlighted the importance of collecting large multicentre cardiac imaging data from patients with COVID-19 and patients recovering from COVID-19.



3. Vaccination and COVID-19

As for vaccination during COVID-19, there were doubts that the vaccination itself may have caused myocardial infarction and other heart complications. The analysis showed that such complications were very rare, i.e. 3 cases per 100,000, while the development of myocarditis in people without COVID-19 vaccination reached 11 per 100,000 (Barda et al., 2021). A population-based study quantified for the first time the risk of several rare cardiac adverse events associated with three COVID-19 vaccines as well as SARS-CoV-2 infection.

Vaccination for SARS-CoV-2 in adults was associated with a small increase in the risk of myocarditis within a week of receiving the first dose of both adenovirus and mRNA vaccines, and after the second dose of both mRNA vaccines. By contrast, SARS-CoV-2 infection was associated with a substantial increase in the risk of hospitalization or death from myocarditis, pericarditis and cardiac arrhythmia (Patone et al., 2022).

These findings underscore the importance of implementing evidence-based COVID-19 prevention strategies, including vaccination, to reduce the public health impact of COVID-19 and its associated complications.

4. Presentation of COVID-19 myocarditis

Presentation of COVID-19 myocarditis can vary from mild to severe (stated as dyspnea, fatigue, fever, cough, and chest pain). These symptoms are commonly seen in infections with previous phylogenetic viral groups such as SARS-COV or MERS-COV, in the presence or absence of myocarditis. Other symptoms listed are diarrhea, muscle pain, headaches, nausea and vomiting. The respiratory presentation gets further complicated with pre-existing risk factors due to congenital or heart conditions such as myocardial infarction, arrhythmia etc. Increased levels of cardiac biomarkers, electrocardiogram (ECG) findings (i.e. prolongation of the QT interval), non-specific ST-segment and T-wave changes and brady/tachyarrhythmia can be found (Pourfridoni et al., 2022). Global hypokinesia and pericardial effusion can be seen on echocardiography (Kermani-Alghoraishi et al., 2021). Myocardial fibrosis associated with arrhythmia can result in increased septal wall thickness (Ali et al., 2022).

5. Diagnostics of COVID-19 associated myocarditis

Blood test markers that are nonspecific and indicate signs of infection have been noted in COVID-19-associated myocarditis. These markers include Lactate Dehydrogenase (LDH), white blood cell count and C-reactive protein (CRP). Apart from these, cardiac enzyme (e.g., creatine kinase - myoglobin binding (CK-MB), pro B type natriuretic peptide (pro-BNP) and troponin levels have been found elevated (Kaufmann et al., 2022). But in spite of their normal levels, the presence of myocarditis was not necessarily excluded, therefore initial non-invasive investigations were found essential (Escher et al., 2020). ECG parameters like ST-T wave changes, QT prolongation, bradyarrhythmia and tachyarrhythmias are nonspecific since these are also found in other diseases of the heart. ECG can assess hypokinesia of the myocardial wall and rule out other valvular conditions and congenital malformations (Schultz et al., 2009). 2-D echocardiography lacks sensitivity and specificity in terms of identifying systolic and diastolic functioning variations (Sawalha et al., 2021). Computer Tomography (CT) offers better spatial resolution and due to its short acquisition time, it is useful in identifying fibrosis and abnormalities of cardiac wall motion, but it is being used for delayed enhancement (Chen and Jeudy, 2019). Nevertheless, EMB, it is the gold standard for confirmation of myocardial inflammation or fibrosis (Tavazzi et al., 2020). On the other hand, EMB carries a significant risk of arrhythmias, bleeding, nerve or vascular complications, perforation and pneumothorax (Mandoli et al., 2021). "Lake Louise Criteria" should be considered while interpreting CMR images (Cundari et al., 2021). CMR which uses T2-weighted, early and late gadolinium enhancement was suggested to be the best non-invasive technique as regards sensitivity (Puntmann et al., 2018) but failed to identify the aetiology (viral or autoimmune) so in this case, EMB could be a better choice (Chu et al., 2013). Ongoing developments are seeking for more objective, quantitative tissue markers for inflammation and necrosis or scar, and semiautomatic algorithms for image acquisition and evaluation (Chen and Jeudy, 2019).



6. Arrhythmias in post-COVID-19.

Arrhythmia can be the first and only symptom of myocarditis (Blagova et al., 2021). If the patient suddenly develops an arrhythmia of unknown origin, a possibility of myocarditis can be taken into account (Li et al., 2020). Development of arrhythmia at different stages of development of myocarditis corresponds to different mechanisms (Li et al., 2020). It was suggested that an increased risk of arrhythmias in patients with COVID-19 is most likely a consequence of systemic diseases, not just a direct consequence of the viral infection (Ak-kawi and Ghazal, 2021).

In 2020, a large study within European countries in the time interval of seven months showed that in many patients, the symptoms connected to COVID-19 persisted (mainly cardiac symptoms: chest pain and or tightness in the chest, shortness of breath, fatigue, sleep disturbance, night apnea, tachycardia, bradycardia) (Davis et al., 2021). The patients had not returned to previous levels of work and continued to experience significant symptom burden (Davis et al., 2021).

According to the current literature, we can find the following arrhythmogenic hypothetical mechanisms in the acute phase of viral myocarditis:

- i*, Direct cytopathic effect, which leads to electrical instability due to lysis of myocyte membranes (Agol, 2012).
- ii*, Ischemia as a result of a coronary macro- or microvascular lesion, for example, in viruses with endothelial tropism (Paravirus B 19) as a result of P antigen-mediated dysfunction of the endothelium (Petersen and Pepine, 2015)
- iii*, Dysfunction of the intercellular gap junction (gap junction dysfunction) due to impaired connexin expression in the myocardium, as shown in coxsackie virus-induced myocarditis in animal models (Hesketh et al., 2009)
- iv*, Disturbance of calcium transport and the functioning of ion channels, especially in myocarditis due to overlap with arrhythmic cardiomyopathy or channelopathies (Shah et al., 2006).

A possible explanation for why patients with COVID -19 report heart rhythm disturbances (tachy- or bradycardia) is SARS-CoV-2 infection of the pacemaker cells of the sinoatrial node, which leads to a marked increase in ferroptosis (Nishiga et al., 2022). Ferroptosis (English: ferroptosis) is a type of programmed oxidative necrotic cell death, a characteristic feature based on the iron-dependent peroxidation of lipids. On experimental basis, deferoxamine and imatinib were found to block ferroptosis associated with SARS-CoV-2 infection (Han et al., 2022).

The studies on arrhythmias after COVID 19 myocarditis are very few. Arrhythmia specification of post-COVID-19 myocarditis was performed at Strazhesko Cardiology Institute of Ukraine (Kovalenko et al., 2020). The first group included patients with acute myocarditis and COVID-19 infection in anamnesis (n=25, male 53%, female 47%, age 35,3 ± 2,5 years) and the second group included patients with myocarditis without COVID-19 infection in anamnesis and negative polymerase chain reaction (PCR) (n=20, male 60% female 40%, age 34,9 ± 2,3 years). The diagnosis of acute myocarditis was established based on current recommendations with cardiac magnetic resonance imaging. In the first group, there was a significantly higher number of ventricular extrasystoles (VE) (53%), supraventricular extrasystoles SE (25%), paired VEs (by 27%), and episodes of ventricular allorhythmia (12%) compared to the second group (Kovalenko et al., 2020). Ventricular and supraventricular arrhythmias were observed more often in patients with myocarditis who suffered from COVID – 19, regardless of gender.

MRI in patients of the first group showed a larger volume of inflammatory and fibrotic lesions of the left ventricle (LV), which was evidenced by a larger number of LV segments in which both inflammatory changes and delayed contrast were detected (Kovalenko et al., 2020). In most cases, patients with a history of COVID - 19 infection had more damage to the ventricular septum (Kovalenko et al., 2020). From the data of this study, it could be



deduced that that fibrotic changes which developed during myocarditis were correlated with the number of supraventricular and ventricular arrhythmias (Kovalenko et al., 2020). It was suggested that supraventricular arrhythmia developed more often due to inflammatory processes and ventricular extrasystoles developed more often due to fibrotic damage (Kovalenko et al., 2020). In patients from group 1, damaged posterior and lateral walls of the left ventricle were correlated with supraventricular extrasystoles while damaged ventricular septum was correlated with ventricular extrasystoles and supraventricular tachycardia (Kovalenko et al., 2020).

In a study performed in Tbilisi in 2022, the assessment of cardiac autonomic imbalance was based on heart rate measurements obtained during 24-hour Holter monitoring (Malidze et al., 2022). Parameters of Heart rate Variability (HRV) were assessed in 2 groups randomized with respect to age and gender. The 1st group included patients with acute myocarditis after COVID -19 infection, and the second group included patients with acute myocarditis without COVID 19 infection in anamnesis, which was confirmed by negative serological studies. Patients were not vaccinated against COVID -19. A more pronounced decrease in the activity of the parasympathetic peripheral nervous system of the heart rhythm was revealed in patients who had COVID -19 infection, standard deviation normal to normal intervals (SDNN), 103 ± 25 ms vs 128 ± 32 ms, $p < 0.001$ and high frequency (HF), 235 ± 198 ms vs 473 ± 179 ms, $p < 0.001$ (Malidze et al., 2022).

It was suggested that impairment of sympathetic-vagal balance of the heart rhythm regulation lowers the excitability threshold of cardiac cells in post-COVID syndrome patients and can contribute to the development of the electrical instability of the myocardium and the occurrence of arrhythmias (Malidze et al., 2022).

7. Treatment of COVID-19-associated myocarditis

Corticosteroids in addition to antiviral therapy, colchicine, immunoglobulins and immuno-modulators have decreased mortality rates in patients with or without pre-existing comorbidities (Feuillet et al., 2021). Current research indicates that the effect of corticosteroids hydrocortisone and oral prednisone is on immune system since increased amounts of cytokines and chemokines have been detected in patients with multiple organ dysfunction related to SARS-CoV-2 (Kamarullah et al., 2021).

Positive chronotropic (e.g. dopamine) agents are considered for atrioventricular block, instead of the transvenous pacemaker to minimize personal protective equipment use and healthcare worker's risk (Limanaqi et al., 2022). It was suggested to postpone permanent pacemaker implantation to allow for an improvement of bradycardia (Kochav et al., 2020).

For atrial fibrillation in stable patients in the absence of heart failure, rate control and anticoagulation are suggested while in hemodynamically unstable patients, urgent cardioversion was found necessary (Holt et al., 2020). Apart from this, calcium channel blockers or digoxin and beta blockers have been used for controlling conduction through the atrioventricular node (Holt et al., 2020). To assess left atrial appendage thrombus, CT angiography was suggested instead of Transoesophageal Echocardiography (TEE) due to the risk of viral aerosolization (Hu et al., 2020). It is still unclear how long systemic anticoagulation should be used for prothrombotic state associated with severe viral infection (Kochav et al., 2020). Clinicians or healthcare workers should consider drug-drug interactions while giving antivirals to prevent unnecessary side effects or toxicity. It was reported that amiodarone has been used for a short time in a patient with hypertension and cardiomyopathy (Hu et al., 2020). Depending upon the patient's risk profile, anticoagulation was recommended while the patient was being monitored (Hu et al., 2020). Cardiac troponin measurement and an echocardiogram were suggested for further evaluation (Hu et al., 2020). QT corrected (QTc) interval - prolonging drugs (e.g., hydroxychloroquine) were found to trigger arrhythmias (Lewis et al., 2020) which should be taken into account. To avoid polymorphic ventricular tachycardia and pulseless electrical activity, potassium and magnesium deficiency should be monitored and repleted (Kochav et al., 2020). Defibrillation was suggested as an option for sustained arrhythmias of ventricles (Hu et al., 2020). Implantation of cardioverter-defibrillator (ICD) for secondary prevention was suggested in patients with myocarditis and symptomatic ventricular arrhythmias, especially if these persisted after the acute phase despite pharmacotherapy (Hu et al., 2020). However, the



timing of implanting ICD remains unclear (Wadhvani et al., 2021). Implantation of a cardiac device for the treatment of ventricular arrhythmias (VA) is indicated 3-6 months after the acute phase (Wadhvani et al., 2021). Body-worn external cardioverter defibrillator has been considered in patients at high risk of sudden death, patients with lymphocytic myocarditis, and patients with myocarditis and ventricular arrhythmias in the acute phase of the disease (Wadhvani et al., 2021). However, the best terms for its use have not been prospectively investigated (Dherange et al., 2020).

Conclusions

The incidence of COVID-19-induced myocarditis and its mortality is not well established. In patients with myocarditis, in any phase of the disease, complex and heterogeneous arrhythmias can occur, which vary from conduction system disturbances of the heart to life-threatening ventricular tachycardia and ventricular fibrillation. Myocarditis is often underdiagnosed, and the occurrence of arrhythmia may be a sign of its debut. Myocarditis with heart rhythm and conduction system disturbances requires specific diagnostic imaging methods for choosing treatment tactics

Conflicts of Interest: The author declared no potential conflicts of interest with respect to the research authorship and publication of this article.

References

1. Agol VI. Cytopathic effects: virus-modulated manifestations of innate immunity? *Trends in Microbiology*. 2012; 20(12): 570–576. DOI: 10.1016/j.tim.2012.09.003
2. Akkawi AR, Ghazal M. COVID-19 and Cardiac Arrhythmias: A Review of the Literature. *Cureus*. 2021; 13: e17797. DOI: 10.7759/cureus.17797
3. Ali MS, Shiwani HA, Elfaki MY, et al. COVID-19 and myocarditis: a review of literature. *Egypt Heart J*. 2022; 74: 23. DOI: 10.1186/s43044-022-00260-2
4. Barda N, Dagan N, Ben-Shlomo Y, et al. Safety of the BNT162b2 mRNA Covid-19 Vaccine in a Nationwide Setting. *N Engl J Med*. 2021; 385: 1078-1090. DOI: 10.1056/NEJMoa2110475
5. Blagova OV, Varionchik, NV, Zaidenov VA, et al. Previous and First Detected Cardiovascular Diseases in Patients with New Coronavirus Pneumonia: Possible Mechanisms and Place in a Unified Prognostic Model. *Int Arch Allergy Immunol*. 2021; 182: 765–774. DOI: 10.1159/000515253
6. Boehmer TK, Kompaniyets L, Lavery AM, et al. Association between COVID – 19 and Myocarditis Using Hospital - Based administrative Data-United States, March 2020-January 2021. *MMWR Morb Mortal Wkly Rep*. 2021; 70: 1228-1232. DOI: 10.15585/mmwr.mm7035e5
7. Chen W, Jeudy J. Assessment of Myocarditis: Cardiac MR, PET/CT, or PET/MR? *Current Cardiology reports*. 2019; 21(8): 76. DOI: 10.1007/s11886-019-1158-0
8. Chu GC, Flewitt JA, Mikami Y, et al. Assessment of acute myocarditis by cardiovascular MR: diagnostic performance of shortened protocols. *Int J Cardiovasc Imaging*. 2013; 29: 1077-1083. DOI:10.1007/s10554-013-0189-7
9. Chung MK, Zidar DA, Bristow MR, et al. COVID-19 and cardiovascular disease: from bench to bedside. *Circ Res*. 2021; 128: 1214–1236. DOI: 10.1161/CIRCRESAHA.121.317997
10. Cundari G, Galea N, De Rubeis G, et al. Use of the new Lake Louise Criteria improves CMR detection of atypical forms of acute myocarditis. *Int J Cardiovasc Imaging*. 2021; 37: 1395-1404. DOI: 10.1007/s10554-020-02097-9
11. Davis HE, Assaf GS, McCorkell L, et al. Characterizing long COVID in an international cohort: 7 months of symptoms and their impact. *EClinicalMedicine*. 2021; 38:101019. DOI: 10.1016/j.eclinm.2021.101019
12. Dherange P, Lang J, Qian P, et al. Arrhythmias and COVID-19: A Review. *JACC Clin Electrophysiol*. 2020; 6: 1193-1204. DOI: 10.1016/j.jacep.2020.08.002
13. Escher F, Pietsch H, Aleshcheva G, et al. Detection of viral SARS-CoV-2 genomes and histopathological changes in endomyocardial biopsies. *ESC Heart Fail*. 2020; 7: 2440-2447. DOI: 10.1002/ehf2.12805
14. Feuillet V, Canard B, Trautmann A. Combining Antivirals and Immunomodulators to Fight COVID-19. *Trends in immunology*. 2021; 42: 31–44. DOI: 10.1016/j.it.2020.11.003
15. Han Y, Zhu J, Yang L, et al. SARS-CoV-2 Infection Induces Ferroptosis of Sinoatrial Node Pacemaker Cells. *Circ Res*. 2022; 130: 963-977. DOI: 10.1161/CIRCRESAHA.121.320518



16. Hesketh GG, Van Eyk JE, Tomaselli GF. Mechanisms of gap junction traffic in health and disease. *Journal of cardiovascular pharmacology*. 2009; 54: 263–272. DOI: 10.1097/FJC.0b013e3181ba0811
17. Holt A, Gislason GH, Schou, et al. New-onset atrial fibrillation: incidence, characteristics, and related events following a national COVID-19 lockdown of 5.6 million people. *European heart journal*. 2020; 41: 3072–3079. DOI: 10.1093/eurheartj/ehaa494
18. Hu YF, Cheng WH, Hung Y, et al. Management of Atrial Fibrillation in COVID-19 Pandemic. *Circulation journal : official journal of the Japanese Circulation Society*. 2020; 84: 1679–1685. DOI: 10.1253/circj.CJ-20-0566
19. Ismayl M, Abusnina W, Thandra A, et al. Delayed acute myocarditis with COVID-19 infection. *Proc (BAYL Univ Med Cent)*. 2022; 35: 366–368. DOI: 10.1080/08998280.2022.2030189
20. Kaufmann CC, Ahmed A, Burger AL, et al. Biomarkers Associated with Cardiovascular Disease in COVID-19. *Cells*. 2022; 11: 922. DOI: 10.3390/cells11060922
21. Kamarullah W, Nurcahyani, Mary Josephine C, et al. Corticosteroid Therapy in Management of Myocarditis Associated with COVID-19; a Systematic Review of Current Evidence. *Arch Acad Emerg Med*. 2021; 9: e32. DOI: 10.22037/aaem.v9i1.1153
22. Kermani-Alghoraishi M, Pouramini A, Kafi F, Khosravi A. Coronavirus Disease 2019 (COVID-19) and Severe Pericardial Effusion: From Pathogenesis to Management: A Case Report Based Systematic Review. *Current problems in cardiology*. 2022; 47: 100933. DOI: 10.1016/j.cpcardiol.2021.100933
23. Kochav SM, Coromilas E, Nalbandian A, et al. Cardiac Arrhythmias in COVID-19 Infection. *AHA Journals. Circ: Arrhythmia and Electrophysiology*. 2020; 13: 6. DOI: 10.1161/CIRCEP.120.008719
24. Kovalenko VN, Nesukay EG, Kornienko TM, Titova NS. COVID-19 Pandemic and Cardiovascular Disease *Ukrainian Journal of Cardiology*. 2020; 27: 10–17. DOI: 10.31928/1608-635X-2020.2.1017
25. Lewis J, Gregorian T, Portillo I, Goad J. Drug interactions with antimalarial medications in older travelers: a clinical guide. *Journal of Travel Medicine*. 2020; 27: taz089. DOI: 10.1093/jtm/taz089
26. Limanaqi F, Zecchini S, Dino B, et al. Dopamine Reduces SARS-CoV-2 Replication In Vitro through Downregulation of D2 Receptors and Upregulation of Type-I Interferons. *Cells*. 2022; 11:1691. DOI: 10.3390/cells11101691
27. Li X, Pan X, Li Y, et al. Cardiac injury associated with severe disease or ICU admission and death in hospitalized patients with COVID-19: a meta-analysis and systematic review. *Critical care (London, England)*. 2020; 24: 468. DOI: 10.1186/s13054-020-03183-z
28. Malidze D, Noniashvili M. Accelerated heartbeat in post covid syndrome: what is behind it? XXIII National Congress of cardiologist of Ukraine, 22.09.2022. Accessed at <https://cardiocongress.org.ua/#online>
29. Mandoli GE, D'Ascenzi F, Vinco G, et al. Novel Approaches in Cardiac Imaging for Non-invasive Assessment of Left Heart Myocardial Fibrosis. *Frontiers in Cardiovascular Medicine*. 2020; 8: 614235. DOI: 10.3389/fcvm.2021.614235
30. Nishiga M, Jahng JWS, Wu JC. Ferroptosis of Pacemaker Cells in COVID-19. *Circulation Research*, 2022; 13: 978–980. DOI: 10.1161/CIRCRESAHA.122.320951
31. Patone M, Mei XW, Handunnetthi L, et al. Risks of myocarditis, pericarditis, and cardiac arrhythmias associated with COVID-19 vaccination or SARS-CoV-2 infection. *Nat Med*. 2022; 28: 410-422. DOI: 10.1038/s41591-021-01630-0
32. Petersen JW, Pepine CJ. Microvascular coronary dysfunction and ischemic heart disease: where are we in 2014? *Trends in Cardiovascular Medicine*. 2015; 25: 98–103. DOI: 10.1016/j.tcm.2014.09.013
33. Pourfridoni M, Khan MAB, Khalil-Khan A, et al. Elevated troponin level and nonspecific ST-segment and T-wave changes in a suspected acute pancreatitis patient, post-SARS-Cov-2 infection: A case report. *Clinical Case Reports*. 2022; 10: e6628. DOI: 10.1002/ccr3.6628
34. Puntmann VO, Zeiher AM, Nagel E. T1 and T2 mapping in myocarditis: seeing beyond the horizon of Lake Louise criteria and histopathology. *Expert Rev Cardiovasc Ther*. 2018; 16: 319-330. DOI: 10.1080/14779072.2018.1455499
35. Sawalha K, Abozenah M, Kadado AJ, et al. Systematic review of COVID-19 related myocarditis: insights on management and outcome. *Cardiovascular Revascularization Medicine*. 2021; 23: 107-113. DOI: 10.1016/j.carrev.2020.08.028
36. Schultheiss HP, Baumeier C, Pietsch H, Bock CT, et al. Cardiovascular consequences of viral infections: from COVID to other viral diseases. *Cardiovascular Research*. 2021; 117: 2610–2623. DOI: 10.1093/cvr/cvab315
37. Schultz JC, Hilliard AA, Cooper Jr LT, Rihal CS. Diagnosis and treatment of viral myocarditis. *Mayo Clin Proc*. 2009; 84: 1001-1009. DOI: 10.1016/S0025-6196(11)60670-8
38. Shah VN, Chagot B, Chazin WJ. Calcium-Dependent Regulation of Ion Channels. *Calcium Binding Proteins*. 2006; 1: 203–212.
39. Siddiqi HK, Libby P, Ridker PM. COVID-19 – A vascular disease. *Trends Cardiovasc Med*. 2021; 31: 1-5. DOI: 10.1016/j.tcm.2020.10.005



40. Tanacli R, Doeblin P, Götze C, Zieschang V, Faragli A, Stehning C, et al. COVID-19 vs. Classical Myocarditis Associated Myocardial Injury Evaluated by Cardiac Magnetic Resonance and Endomyocardial Biopsy. *Front Cardiovasc Med.* 2021; 8: 737257. DOI: 10.3389/fcvm.2021.737257
41. Tavazzi G, Pellegrini C, Maurelli M, et al. Myocardial localization of coronavirus in COVID-19 cardiogenic shock. *European Journal of Heart Failure.* 2020; 22: 911-915. DOI: 10.1002/ejhf.1828
42. Tschöpe C, Ammirati E, Bozkurt B, et al. Myocarditis and inflammatory cardiomyopathy: current evidence and future directions. *Nature Reviews Cardiology.* 2021; 18: 169-193. DOI: 10.1038/s41569-020-00435-x
43. Wadhvani L, Occhipinti K, Selim A, et al. Time to diagnosis of acute complications after cardiovascular implantable electronic device insertion and optimal timing of discharge within the first 24 hours. *Heart Rhythm.* 2021; 18: 2110–2114. DOI: 10.1016/j.hrthm.2021.09.008





Invited lecture/Scientific contribution

Diagnostic and Prognostic Analysis of Serological and Bio-chemical Markers in Patients with COVID-19: A Retrospective Study

Bansal Rishu ^{1,*}, Zhamutashvili Maia ^{1,2}, Tilante Shweta¹, Kipiani Nina¹, Badridze Nino¹, Dolmazashvili Ekaterine ^{1,2}, Jojua Natia ¹, Gognadze Tinatin¹

^{1.} European University, Tbilisi, Georgia

^{2.} Infectious diseases, Aids and Clinical-Immunology Scientific-Research Center, Tbilisi, Georgia

* Correspondence: Rishu Bansal; 6990@eu.edu.ge

Citation: Bansal R, Zhamutashvili M, Tilante S, Kipiani N, Badridze N, Dolmazashvili E, Jojua N, Gognadze T. Diagnostic and Prognostic Analysis of Serological and Bio-chemical Markers in Patients with Covid-19: A retrospective study. Proceedings of Socratic Lectures. 2023, 8; 10-13.
<https://doi.org/10.55295/PSL.2023.II2>

Publisher's Note: UL ZF stays neutral with regard to jurisdictional claims in published maps and institutional affiliations.



Copyright: © 2023 by the authors. Submitted for possible open access publication under the terms and conditions of the Creative Commons Attribution (CC BY) license (<https://creativecommons.org/licenses/by/4.0/>).

Abstract:

The Coronavirus Disease 2019 (COVID-19) pandemic caused by the Severe Acute Respiratory Syndrome Coronavirus 2 (SARS-CoV-2) became a challenge globally by affecting millions of people worldwide. Lung injury is the main outcome of COVID-19 infection; however, damage can occur in other organs including the liver. Currently, limited data is available that link underlying liver injury with the severe SARS-CoV-2 infection. This study aimed to investigate the changes in levels of liver enzymes in COVID-19 patients. We conducted a retrospective analysis of the medical reports of 90 admitted patients with confirmed COVID-19 in the Infectious Disease, AIDS and Clinical Immunology Research Centre, Georgia from march 2020 till August 2020. The study showed that among 90 patients with COVID-19, 24.4% (n=22) had abnormally elevated levels of liver enzymes. The presence of abnormal liver tests became more pronounced during hospitalization within 2 weeks, with 18.8% (n=17) patients having elevated alanine aminotransferase (ALT) levels, and 12.2% (n=11) patients having elevated aspartate aminotransferase (AST) levels. Considerably raised levels of liver enzymes were observed in 17.8% (n=16) older males. The hepatitis C virus antibody test and hepatitis B virus antigen test were performed in all patients and only two patients were detected with positive result of hepatitis C and hepatitis B tests. Our study indicates that patients with abnormal liver tests were at higher risk of progressing to severe COVID-19. Large-scale clinical studies are needed in the future to identify the causes of liver injury in patients with COVID-19 infection.

Keywords: COVID-19, Liver enzymes, ALT (alanine aminotransferase), AST (aspartate aminotransferase), Ag(antigen), Ab(antibody).



1. Introduction

The Coronaviridae family includes members that express similar homology in terms of structure and pathology and includes Middle East Respiratory Syndrome (MERS-CoV), SARS-CoV, and SARS-CoV-2 that presents a global challenge since December 2019 (Schneeweiss-Gleixner, 2021). COVID-19 mainly affects the respiratory system but the involvement of other systems is of equal importance because Angiotensin-Converting Enzyme (ACE) receptors are widely spread within the body. ACE2 is present in many organs (e.g. intestine, heart, liver, kidney, nervous and muscular system) and is the main receptor for viral attachment (Nardo et al., 2021). The pathway is regulated by the host transmembrane serine protease 2 (TMPRSS2) (Nardo et al., 2021). The possible effect of preexisting disease in the liver might be important and needs further investigation of the underlying pathophysiological mechanisms leading to severe progression (Nardo et al., 2021). Most studies on COVID-19 patients showed evidence of alveolar damage (Menter et al., 2020), but liver damage has also been detected (Jothimani et al., 2020). The presence of the SARS virus in liver tissue was detected by Reverse Transcriptase Polymerase Chain Reaction (RT-PCR) but not by observation of virions by electron microscope (Anirvan et al., 2020). It could be expected that in COVID-19 the liver enzymes would be elevated since SARS-CoV-2 shares genomic similarities with SARS-CoV (Anirvan et al., 2020). Liver dysfunction can be caused by direct and indirect cytopathic effects. The direct cytopathic effect is caused by the direct interaction of SARS-CoV-2 with the host cell via ACE2 which is expressed in cholangiocytes. Surprisingly, the ACE2 expression was found higher in the bile duct than in hepatocytes which indicates that liver damage might be associated with bile duct injury and cholestatic liver injury. It was found that cholangiocytes served as a protective barrier for liver cells because of tight junctions, but the virus reduced the expression of tight junctions mRNA which in turn can leak out toxic bile contents into the hepatocellular parenchyma (Nardo et al., 2021). Transient elevation of liver enzymes can occur due to immune activation reflected in the increase of cytokines including interleukins IL-2R, IL-6, and IL-10, and tumor necrosis factor-alpha (TNF- α) also without any significant liver injury (Hamid et al., 2021). Genetic factors might be responsible for cytokine storms in response to viral specificity (Benetti et al., 2020). Positive end-expiratory pressure impeding venous return can be a reason for elevated pressure in the right atrium and can occur with or without mechanical ventilation. Drugs such as antivirals, antipyretics, and antibiotics may be associated with liver dysfunction or enzyme elevation (Vitiello et al., 2021). Older age and comorbid conditions such as hypertension, diabetes, and cardiovascular diseases render patients more susceptible to infection due to their poor immune status (Musa, 2020). Severe hepatitis has been noticed in patients with Hepatitis-B Co-infection with SARS-CoV-2 (Wu et al., 2021). Evidence from Wuhan, China showed that liver enzymes were predominantly elevated in severe patients with COVID-19. The majority of patients in this study were males with a mean age of 47 years and the majority of patients with elevated enzymes were on antiretroviral medications, therefore it was not clear whether the elevation of the liver enzymes was due to medication or a direct effect of virus. A recent study reported the presence of fever and respiratory symptoms in a COVID-19 patient who had acute anicteric hepatitis (Hamid et al., 2021). Aside from pulmonary symptoms, other clinical manifestations of the interaction of the virus with ACE2 receptors have been noted (Boregowda et al., 2020). Recent findings of anosmia and ageusia have been considered important symptoms (Boregowda et al., 2020). On the other hand, Gamma Glutamyl Transpeptidase (GGT) elevation has been reported in severe cases while Alkaline Phosphatase (ALP) levels were normal in mild to severe cases. It was suggested that outpatients without records of underlying liver disease could be managed by quarantine and routine examination of liver biomarkers is not necessary whereas, for the patients with severe progression, it was found of utmost importance (Hamid et al., 2021). It was suggested that AST, ALT, ALP, GGT, and bilirubin should be monitored on a routine basis in severe cases (Hamid et al., 2021). In some of these cases, C reactive protein, ferritin, albumin, and platelets were also found informative (Hamid et al., 2021). It was found that in order to exclude drug-related liver injury, newly founded abnormal liver parameters were managed in the same way as in the COVID-19-negative patients (Hamid et al., 2021). Increased levels of ALP and bilirubin were detected in the severe form of liver injury (Clark et al., 2021), however, the mechanism behind this is still not known. Disseminated intravascular coagulation, and thrombosis was also associated with COVID-19 (Phipps et al., 2020), but

measuring International Normalized Ratio (INR) has not been introduced as a requirement in clinical practice. However, it could be considered useful since the mild increase in INR along with hypoalbuminemia has been detected in severe COVID-19 cases (Phipps et al., 2020). D-dimer is a breakdown product of fibrin and plays a role in the activation and degradation of the coagulation pathway (Berger et al., 2020). D-dimer elevations were observed in chronic diseases (Berger et al., 2020). In Wuhan, China, assessment of coagulopathy and D-dimer was used in prognostics, decisions on the treatment, and follow-up of COVID-19 patients (Li et al., 2020). Also, it was shown that the biomarkers varied with respect to gender which was interpreted by differences in biology and lifestyle (e.g. smoking) (Haitao et al., 2020).

2. Methods

A retrospective analysis of the medical reports of 90 admitted patients with confirmed COVID-19 treated at the Infectious Disease, AIDS and Clinical Immunology Research Centre, Tbilisi, Georgia from March 2020 to August 2020 was performed. Patients in severe stages of liver injury were followed routinely for concentrations of liver biomarkers, platelets, and albumin in the blood. Biochemical parameters: concentrations of ALT and AST in blood were considered. The hepatitis C virus antibody test and hepatitis B virus antigen test was performed in all patients.

3. Results

The study showed that among 90 patients with COVID-19, 24.4% (n=22) had elevated concentrations of liver enzymes in blood at admission to the hospital (**Figure 1**) while after two weeks in the hospital, the number of patients with elevated ALT decreased to 18.8% (n=17) and the number of patients with elevated AST decreased to 12.2% (n=11). The levels of liver enzymes in the blood were considerably increased in 17.8% (n=16) of older males. One patient was found positive for hepatitis C virus antibody and one patient was found positive for hepatitis B surface antigen.

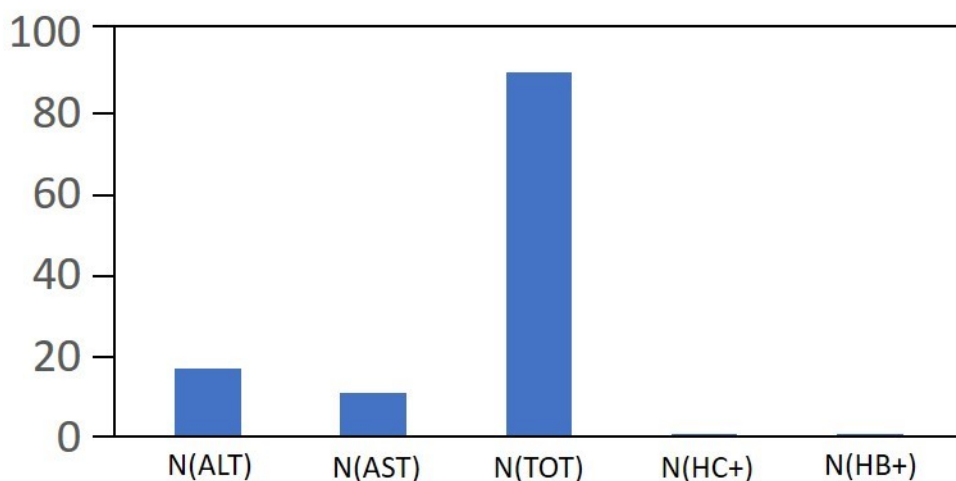

Figure 1. Numbers of patients (N) with elevated ALT and AST liver enzymes in blood and numbers of patients positive for hepatitis C virus antibody (HC+) and hepatitis B surface antigen (HB+) in the cohort of total number N(TOT) of patients with COVID-19.

3. Discussion

COVID-19 has impacted people's lives worldwide, not only biologically but also mentally and economically. Our results indicate that SARS-CoV-2 besides affecting the pulmonary system presented also with elevated liver tests (**Figure 1**). We found elevated liver enzymes mostly in elderly men which could be explained on the grounds of gender and lifestyle. Levels of biomarkers were found elevated in many chronic liver diseases (Yu et al., 2021). however, the mechanisms of association of COVID-19 with liver impairment have



not yet been explained. High mortality rates have been identified in COVID-19 patients with or without underlying liver disease. It was suggested that concentrations of ALP, ALT, AST, D-dimer, and bilirubin in all patients with severe COVID-19 would be helpful for prognostics and in decisions about the treatment. Studies in this field require further investigations (Clark et al., 2021).

Conflicts of Interest: The authors declare no conflict of interest.

References

1. Anirvan P, Bharali P, Gogoi M, et al. Liver injury in COVID-19: The hepatic aspect of the respiratory syndrome - what we know so far. *World J Hepatol.* 2020; 12: 1182-1197. DOI: 10.4254/wjh.v12.i12.1182
2. Benetti E, Giliberti A, Emiliozzi A, et al. Clinical and molecular characterization of COVID-19 hospitalized patients. *PLoS One.* 2020; 15: e0242534. DOI: 10.1371/journal.pone.0242534
3. Berger JS, Kunichoff D, Adhikari S, et al. Prevalence and Outcomes of D-Dimer Elevation in Hospitalized Patients With COVID-19. *Arterioscler Thromb Vasc Biol.* 2020; 40: 2539-2547. DOI: 10.1161/ATVBAHA.120.314872
4. Boregowda U, Aloysius MM, Perisetti A, et al. Serum Activity of Liver Enzymes is Associated with Higher Mortality in COVID-19: A Systematic Review and Meta-Analysis. *Front Med (Lausanne).* 2020; 7: 431. DOI: 10.3389/fmed.2020.00431
5. Clark R, Waters B, Stanfill AG. Elevated liver function tests in COVID-19: Causes, clinical evidence, and potential treatments. *Nurse Pract.* 2021; 46: 21-26. DOI: 10.1097/01.NPR.0000722316.63824.f9
6. Haitao T, Vermunt JV, Abeykoon J, et al. COVID-19 and Sex Differences: Mechanisms and Biomarkers. *Mayo Clin Proc.* 2020; 95: 2189-2203. DOI: 10.1016/j.mayocp.2020.07.024
7. Hamid S, Alvares da Silva MR, Burak KW, et al. WGO Guidance for the Care of Patients With COVID-19 and Liver Disease. *J Clin Gastroenterol.* 2021; 55:1-11. doi:10.1097/MCG.0000000000001459
8. Jothimani D, Venugopal R, Abedin MF, et al. COVID-19 and the liver. *J Hepatol.* 2020; 73(5): 1231-1240. DOI: 10.1016/j.jhep.2020.06.006
9. Li C, Hu B, Zhang Z, et al. D-dimer Triage for COVID-19. *Acad Emerg Med.* 2020; 27: 612-613. DOI: 10.1111/acem.14037
10. Menter T, Haslbauer JD, Nienhold R, et al. Postmortem examination of COVID-19 patients reveals diffuse alveolar damage with severe capillary congestion and variegated findings in lungs and other organs suggesting vascular dysfunction. *Histopathology.* 2020; 77: 198-209. DOI: 10.1111/his.14134
11. Musa S. Hepatic and gastrointestinal involvement in coronavirus disease 2019 (COVID-19): What do we know till now? *Arab J Gastroenterol.* 2020; 21: 3-8. DOI: 10.1016/j.ajg.2020.03.002
12. Nardo AD, Schneeweiss-Gleixner M, Bakail M, et al. Pathophysiological mechanisms of liver injury in COVID-19. *Liver Int.* 2021; 41: 20-32. DOI: 10.1111/liv.14730
13. Phipps MM, Barraza LH, LaSota ED, et al. Acute Liver Injury in COVID-19: Prevalence and Association with Clinical Outcomes in a Large U.S. Cohort. *Hepatology.* 2020; 72: 807-817. DOI: 10.1002/hep.31404
14. Vitiello A, La Porta R, D'Aiuto V, et al. The risks of liver injury in COVID-19 patients and pharmacological management to reduce or prevent the damage induced. *Egypt Liver Journal.* 2021, 11: 11. DOI: 10.1186/s43066-021-00082-y
15. Wu J, Yu J, Shi X, et al. Epidemiological and clinical characteristics of 70 cases of coronavirus disease and concomitant hepatitis B virus infection: A multicentre descriptive study. *J Viral Hepat.* 2021; 28: 80-88. DOI: 10.1111/jvh.13404
16. Yu D, Du Q, Yan S, et al. Liver injury in COVID-19: clinical features and treatment management. *Virology.* 2021; 18: 121. DOI: 10.1186/s12985-021-01593-1

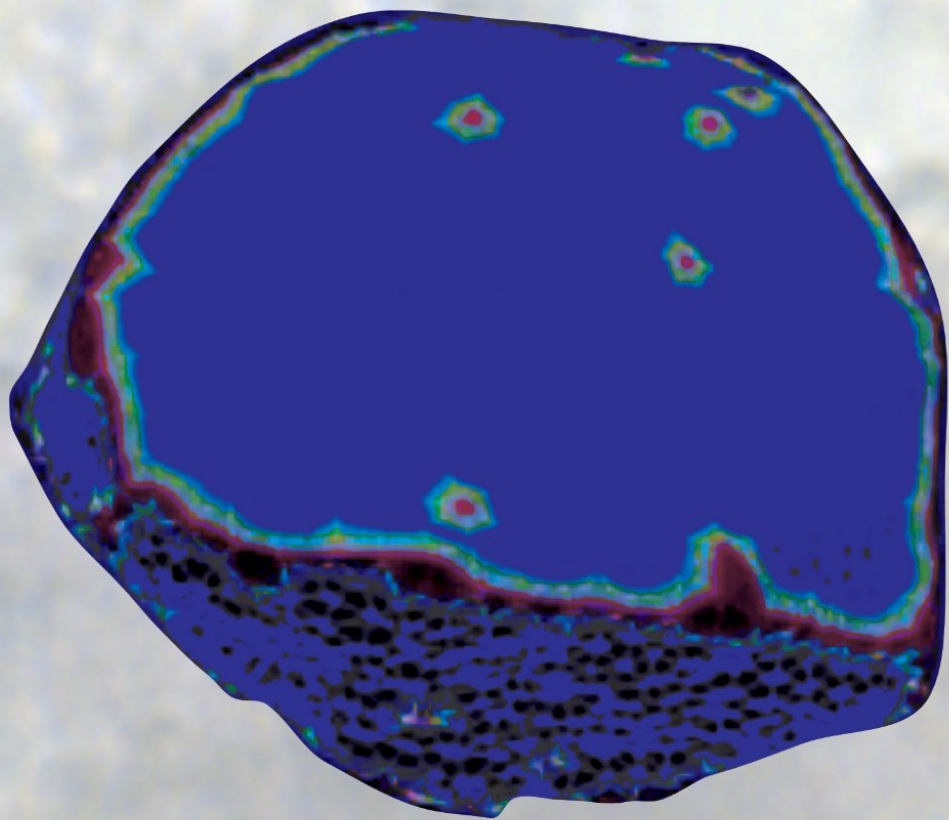

*Invited lecture/Review*

Storage of Platelet-Rich Products

Troha Kaja¹, Vozel Domen^{1,2}, Battelino Saba^{1,2}¹ Department of Otorhinolaryngology and Cervicofacial Surgery, University Medical Centre Ljubljana, Ljubljana, Slovenia.² Faculty of Medicine, University of Ljubljana, Ljubljana, Slovenia.* Correspondence: kaja.troha@gmail.com**Abstract:**

Platelets are a natural source of signaling molecules, growth factors, cytokines and extracellular vesicles that modify the pericellular microenvironment in favor of tissue healing and regeneration. Autologous platelet-rich products, such as platelet-rich plasma are used in many fields of clinical medicine to benefit from these effects. Platelet-rich products are ideally used in more than a single application, but repetitive harvesting of concentrated platelets is time-consuming and impractical for patients and clinicians. In order to maximize the utility of priorly made products and create a supply of patients' own preparations, investigations of appropriate storage of platelet products have emerged. Recent explorations of hypothermic preservation, such as cryopreservation or freeze-drying have shown positive results, providing an efficient possibility of platelet-rich product storage retaining their growth factor, cytokine and chemokine activity.

Citation: Troha K, Vozel D, Battelino S. Storage of platelet-rich products. Proceedings of Socratic Lectures. 2023, 8; 15-21.
<https://doi.org/10.55295/PSL.2023.II3>

Publisher's Note: UL ZF stays neutral with regard to jurisdictional claims in published maps and institutional affiliations.

Keywords: Platelet-rich plasma, Cryopreservation, Freeze-drying, Platelet storage, Cytokines, Growth factors, Healing



Copyright: © 2023 by the authors. Submitted for possible open access publication under the terms and conditions of the Creative Commons Attribution (CC BY) license (<https://creativecommons.org/licenses/by/4.0/>).



1. Introduction.

Blood is an easily obtainable, abundant and dynamic diagnostic and therapeutic material. Clinical application of a blood fraction containing a higher concentration of platelets than whole blood, termed platelet-rich plasma (PRP), has been explored in many medical fields on various tissues to enhance healing by supplying growth factors, cytokines and other bioactive molecules (Andia et al., 2013). More recently, new diagnostic and therapeutic possibilities have emerged by the discovery of other small particles in body liquids (including plasma) termed extracellular vesicles (EVs). These have shown essential roles in transporting membrane proteins, cytosolic proteins and RNA (Tao et al., 2017). In order to emphasize this part of plasma contents, the term platelet and extracellular vesicle-rich plasma (PVRP) has been coined (Vozel et al., 2017; Vozel et al., 2021).

Despite recent optimized procedures of platelet-rich products repetitive production of these products by blood withdrawal and centrifugation is time-consuming and impractical for regular clinical practice (Steiner et al., 2022). In this aspect, several storage options of concentrated platelet-rich products have been investigated. The intention is to preserve ready-made platelet-rich products in a manner without losing their contents over time to the extent of diminishing the beneficial effect, and keep it available to be re-used in tissues, where repeated product applications are beneficial (Andia et al., 2020).

In recent years, several studies have been performed to evaluate the effect of different storage methods on platelet products. The most common measured parameters of storage feasibility are platelet degranulation, the release of functional proteins and their effect on vasculature, cell-growth and inflammation. Most studies focus on demonstrating the equivalence of preserved products to fresh products by comparing different points of platelet-rich product characteristics, such as the concentration levels of growth factors and cytokines relevant in healing mechanisms and the maintenance of their biological activity assessed by *in vitro* and/or *in vivo* functional assays (Andia et al., 2020). Other aspects of platelets have additionally been observed; the morphology of platelet membranes by electron microscopy, growth factor biomarker pattern and their kinetics, as well as their response to agonists, observed by flow cytometry and other modalities (Pan et al., 2016). Most notably involved in tissue repair, platelet-derived growth factor (PDGF), transforming growth factor (TGF), epidermal growth factor (EGF) and vascular endothelial growth factor (VEGF) are commonly investigated in assessing the effect of storage on the function of plasma preparations (Andia et al., 2020; Brogna et al., 2020).

2. Essentials of platelet conservation.

The storage of platelet preparations was the subject of interest already when the sole purpose of concentrating platelets was transfusion. Until 1970s, cold storage at 4°C was the standard preservation technique for platelet concentrates, supported by the facts that the decreased metabolic rate preserves the product's blood clotting abilities and provides optimal bacterial growth inhibition (Becker et al., 1973). It was later described that platelets at room temperature show better *in vivo* survival after transfusion than preserved in cold environment (Becker et al., 1973; Murphy et al., 1971). Murphy et al. (1969) described the storage of platelets in the form of platelet-rich plasma and proposed to change the convention of cold storage to preserving products at 22 °C for maximum 4 days. Indeed, since Murphy's morphologic, metabolic and functional studies of platelets, platelet concentrates have been most commonly preserved on room temperatures (20-24 °C) in gas permeable bags with constant mixing. These measures prevent blood clotting and maintain the viability of platelet cells by promoting gas exchange. In this manner, the time of conservation has been shown to be limited to 5 to 7 days, most significantly due to bacterial contamination hazard and platelet viability deterioration (Waters et al., 2018).

During prolonged platelet storage a specific deterioration of function and viability of platelets occurs, referred to as the platelet storage lesion. The aim of efficient platelet storage is to keep them in a resting, non-activated state to retain their function. It has been found that with longer shelf-life at least a partial activation occurs (Seghatchian et al., 2001). This is observed as the release of alpha granules, altered glycoprotein expression and increased procoagulant activity with up-regulated glycolysis with elevated lactic acid concentration. The latter results in pH drop, deteriorating the viability of preparation (Rinder et al., 1991).



In cold or cryopreserved stored preparations, similar processes take place (Sandgren et al., 2006; Wood et al., 2016).

According to the current Blood Transfusion Centre of Slovenia guidelines, pathogen inactivated concentrated platelets are safe to use up to 7 days at 22 ± 2 °C [17]. Novel preservation techniques such as timetril sulfoxyd, trehalosis or dry freezing have simplified platelet storage and notably prolonged the utility of these preparations. Indeed, in hypothermic conditions, fresh frozen plasma can be stored from 3 months (in conditions of -18°C) to 3 years (in conditions of -25°C) (Adams et al., 2015).

Four basic cold storage options exist for platelets as for other cells and tissues; hypothermic storage, cryopreservation (deep freezing), vitrification and freeze-drying (lyophilization). **Table 1** portrays the basic elements of different preservation methods (Cryopreservation and Freeze-Drying Protocols, 2022). Vitrification is the process of rapid cooling of the liquid medium in the absence of ice crystal formation.

Table 1. Different preservation methods for cells and tissues. Based on “Cryopreservation and Freeze-drying Protocols” (Adams, 2015).

	Hypothermic storage	Cryopreservation	Vitrification	Freeze-drying
Process	isothermal	slow cooling	rapid cooling	slow cooling sublimation desorption
Storage temperature	-4 °C	below -15°C	below -150 °C	room temperature (22-24°C)
State	aqueous solution	in frozen/glassy state	in glassy state	in glassy state
Storage duration	short term	long term	long term	long term

3. Mini review of platelet-rich products preservation

3.1 Room temperature

Several studies have discussed the storage of platelet-rich products on room temperature. Bausset et al. (2012) investigated the effect of storage on room temperature on growth factors in autologous PRP. Based on the results, they recommended using the concentrates on room temperature within 3 hours after preparation, even though the concentrations of PDGF and VEGF were shown to be well-sustained up to 6 hours. Previously, Marx reported that PRP remains stable for up to 8 hours after preparation, but release 70% of their growth factors within 10 min after activation and almost 100% within an hour (Marx et al., 2001). Wilson et al. (2018) reported that TGF- α 1 (transforming growth factor alpha) in PRP retains its activity up to 4 hours at room temperature. Several publications describe an even longer room temperature availability. Moore et al. (2017) measured PDGF over 8 days and concluded that platelet products intended for tissue regeneration could be stored for at least 5 days. Wen et al. (2018) similarly reported the preservation and even rise of growth factors after 7 days room temperature storage in leukocyte rich-PRP.

3.2 Cold storage

Most commonly used cold storage modalities for platelet-rich products are deep freezing and freeze-drying, which is essentially freezing followed by water sublimation and subsequent removal of water vapor. These have been proposed as consistent methods for fabrication of stable products, ready for future use. Recently, DeMello et al. (2022) investigated frozen PRP at -20°C for 6 months on fifteen healthy adult canine patients and observed growth factors levels after freezing and long-term storage (6 months without a preservation agent). The results revealed that all measured growth factors were present in measurable quantities, surviving the long-term storage. Pan et al. (2016) previously examined the release of growth factors in freeze-dried samples and reported that freeze-dried PRP remained rich in growth factors after storage for at least 4 weeks at room temperature.



Hosnuter et al. (2017) presented a study of autologous PRP storage in an office environment at -20°C , in the freezing compartment of a standard refrigerator without using a preservation agent or a special carrier container. EGF, VEGF, PDGF-AB, IGF-1 (Insulin-like growth factor 1), TGF- β , and P-Selectin levels were immediately analyzed in the control group. The growth factors and P-selectin levels were still present, but all growth factors were significantly decreased in the autologous PRP samples stored at -20°C compared to the control group.

Similarly, cold storage of platelet-rich products has been investigated in many fields of PRP or PVRP use, such as wound care, alopecia, musculoskeletal applications, dentistry, ophthalmology and more, some of which are discussed below (Daban et al., 2010; Anitua et al., 2021; Wolkers et al., 2002; Kandil et al., 2020; Shiga et al., 2016; Li et al., 2017).

3.2.1 Wound care

Pietramaggiore et al. (2006) explored the effect of platelet storage in freeze-dried PRP on chronic wounds. In a single dose freeze-dried PRP application to chronic wound with or without bio-stabilization, they evaluated the healing effects and activity of growth factors (TGF, PDGF, VEGF, and EGF) in a diabetic mouse model. Freeze-dried and biochemically stabilized freeze-dried platelets displayed abilities to modulate wound healing, enhancing proliferation of cells and vessel growth in granulation tissue and decreasing wound contraction. The cold storage processing did not affect the intra/extracellular ratio of growth factors, especially when platelets were biochemically stabilized. Using fibroblast proliferation assay, it was additionally investigated whether the preparation of samples affected the ability of platelets to stimulate cell growth in vitro, showing all platelet samples to exert equivalent in vitro abilities to increase cell proliferation compared to the room temperature control. Biochemically stabilized freeze-dried samples have proven to be by 40% more available for the release of growth factors.

3.2.2 Musculoskeletal

The benefits of freeze-dried preparations are besides the prolonged viability of products, the possible storage in the refrigerator or at room temperature in its powder form which is optimal for mixing with other materials, such as the artificial bone. In a study by Koga et al. (2021) the researchers evaluated the lyophilized form of PRP stored at -20°C for 4 weeks and discovered that the preparation remained safe to use in bone engineering up to 4 weeks after freeze-dried storage, with no side effects reported. Roffi et al. (2014) reported that immediate and 7-day release of growth factors of frozen PRP was lower compared to the fresh preparation, but the cold stored preparation effectively preserved the ability to induce proliferation and extracellular matrix production, as shown in chondrocyte and synovioocyte culture. Da Silva et al. (2018) similarly assessed the stability of PDGF, VEGF, TGF and EGF comparing fresh PRP and freeze-dried-PRP. They observed adequate proliferative activity of freeze-dried PRP on human umbilical endothelial cells and fibroblasts. Shiga et al. (2016) also investigated the ability of cold stored human PRP in carrying out the functions of fresh PRP in a rat model on bone union in lumbar fusion surgery. The researchers reported that freeze-dried PRP maintained baseline levels of growth factors during the entire 8-week duration of the study. They analyzed three types of storage; human PRP of stored on room temperature with shaking, frozen PRP stored at -80°C and freeze-dried PRP with no further treatments. Platelet activation rates were assessed via flow cytometry, platelet count and growth factor (PDGF, TGF- α , VEGF - vascular endothelial growth factor and EGF). These were assessed by Growth Factor Membrane Antibody Array immediately after preparation and after 2, 4 and 8 weeks of storage. The authors reported no difference in PDGF concentrations after 4 weeks of storage in -80°C , but they decreased thereafter.

The results showed significantly reduced platelet counts on room temperature after 2 weeks, while the count remained relatively constant in the frozen and freeze-dried samples after 8 weeks of preservation. In room temperature samples almost no growth factors were detected after 8 weeks, the first clear reduction of expression occurring after 2 weeks. In the frozen PRP samples a significant expression of growth factors was maintained at 4 weeks, but decreased by 8 weeks for TGF- α , VEGF 2 and EGF. Freeze-dried samples ex-



hibited only slightly reduced levels of growth factors compared to fresh PRP levels. According to the findings, the researchers suggested that freeze-drying is the most suitable technique for storing PRP to maintain its biologic activity, preserving both platelet count and growth factor levels. They concluded that PRP is best stored at -80°C for 1 month or in dry-freeze state for up to 6 months. Moreover, Li et al. (2017) used 3D-printed bio-material scaffolds for bone tissue engineering coated with freeze-dried PRP and showed significantly greater osteogenic differentiation induction compared to traditionally prepared PRP.

3.2.3 Maxillofacial surgery

Koga et al. (2021) conducted a study with freeze-dried PRP stored at -20°C for 1 month, which was rehydrated and applied in five patients for sinus surgery mixed with bone grafting materials. The results were assessed 4 weeks after the surgery of maxillary sinus floor augmentation showing that the vertical augmented height was maintained and that the preparation remained safe to use in bone engineering up to 4 weeks after freeze-dried storage, with no side effects reported.

3.2.4 Ophthalmology

Lopez-Garcia et al. (2016) observed samples of PRP in eye drop form after 1, 3, 6 and 9 months of storage at -20°C . In the first month evaluations were made at day 0, 1, 2, 3, and 4 weeks. They reported the concentrations of EGF, TGF- $\alpha 1$, PDGF and albumin remained stable over 4 weeks at 4°C in both fresh and defrosted samples. No statistically significant differences were observed between growth factor concentration and the effects on cell proliferation and differentiation of cultured cells in fresh samples and defrosted samples after 1, 3, 4 or 9 months at -20°C . Anitua et al. (2021) similarly analyzed the biological contents and activity of freeze-dried plasma in eye drops after their storage at 4°C and at room temperature for 3 months with respect to fresh samples. They concluded that lyophilized plasma rich in growth factors eye drops conserves their biological features even without the use of lyoprotectants for at least 3 months.

4. Conclusions

In order to avoid potentially painful repetitive blood withdrawals and prolonged in-office visits, storage of priorly prepared autologous blood products has been explored. The preservation of platelet-rich products at low temperatures has been shown as a safe and effective manner of storage, demonstrated by assessments of cytokine and growth factor concentration levels and maintenance of biological activity in various functional assays. Storing samples in the refrigerator or at room temperature in lyophilized form offers a comfortable and simple method of creating a stockpile of therapeutic fluid on disposal for multiple applications, allowing the maximal yield of these preparations on tissues. Larger clinical studies confirming these conclusions as well as the standardization of procedures are required to consider these methods to be used in standard clinical practice.

References

1. Adams GDJ, Cook I, Ward KR. The Principles of Freeze-Drying. In *Cryopreservation and Freeze-Drying Protocols*; Wolkers WF, Oldenhof H, Eds.; Methods in Molecular Biology; Springer: New York, NY. 2015, pp. 121–143.
2. Andia I, Abate M. Platelet-Rich Plasma: Underlying Biology and Clinical Correlates. *Regen Med.* 2013; 8: 645–658. DOI:10.2217/rme.13.59.
3. Andia I, Perez-Valle A, Del Amo C, Maffulli N. Freeze-Drying of Platelet-Rich Plasma: The Quest for Standardization. *Int J Mol Sci.* 2020; 21: E6904. DOI: 10.3390/ijms21186904
4. Anitua E, de la Fuente M, Muruzábal F, Merayo-Llodes J. Stability of Freeze-Dried Plasma Rich in Growth Factors Eye Drops Stored for 3 Months at Different Temperature Conditions. *Eur J Ophthalmol.* 2021; 31: 354–360. DOI: 10.1177/1120672120913035
5. Arav, A. Cryopreservation by Directional Freezing and Vitrification Focusing on Large Tissues and Organs. *Cells* 2022, 11, 1072, doi:10.3390/cells11071072.
6. Becker GA, Tuccelli M, Kunicki T, Chalos MK, Aster RH. Studies of Platelet Concentrates Stored at 22°C Nad 4°C . *Transfusion.* 1973; 13, 61–68. DOI: 10.1111/j.1537-2995.1973.tb05442.x



7. Bausset O, Giraudo L, Veran J, Magalon J, Coudreuse JM, Magalon G, Dubois C, et al. Formulation and Storage of Platelet-Rich Plasma Homemade Product. *Biores Open Access*. 2012; 1: 115–123. DOI:10.1089/biores.2012.0225
8. Brogna R, Oldenhof H, Sieme H, Figueiredo C, Kerrinnes T, Wolkers WF. Increasing Storage Stability of Freeze-Dried Plasma Using Trehalose. *PLoS One*. 2020; 15: e0234502. DOI: 10.1371/journal.pone.0234502
9. Daban JL, Clapson P, Ausset S, Deshayes AV, Sailliol A. Freeze Dried Plasma: A French Army Specialty. *Crit Care*. 2010; 14: 412. DOI: 10.1186/cc8937
10. da Silva LQ, de Lima Montalvão SA, da Silva Justo-Junior A, Rosemberi Cuna Júnior JL, Huber SC, Oliveira CC, Annichino-Bizzacchi, J.M. Platelet-Rich Plasma Lyophilization Enables Growth Factor Preservation and Functionality When Compared with Fresh Platelet-Rich Plasma. *Regenerative Medicine*. 2018; 13: 775-784. DOI: 10.2217/rme-2018-0035
11. De Mello V, Chen G, Wakshlag J, Mason D. Evaluation of Platelet and Leukocyte Counts in Canine Platelet-Rich Plasma Obtained After Successive Blood Collections From the Same Patient and the Effects of Freezing on the Concentration of Growth Factors Present in It. *Front Vet Sci*. 2022; 9: 838481. DOI: 10.3389/fvets.2022.838481
12. Hosnuter M, Aslan C, Isik D, Caliskan G, Arslan B, Durgun M. Functional Assessment of Autologous Platelet-Rich Plasma (PRP) after Long-Term Storage at -20 °C without Any Preservation Agent. *J Plast Surg Hand Surg*. 2017; 51: 235–239. DOI: 10.1080/2000656X.2016.1237956
13. Kandil MI, Tabl EA, Elhammady AS. Prospective Randomized Evaluation of Local Injection of Allogeneic Growth Factors in Plantar Fasciitis. *Foot Ankle Int*. 2020; 41: 1335–1341; DOI:10.1177/1071100720939066
14. Koga T, Nakatani Y, Ohba S, Hara M, Sumita Y, Nagai K, Asahina I. Clinical Safety Assessment of Autologous Freeze-Drying Platelet-Rich Plasma for Bone Regeneration in Maxillary Sinus Floor Augmentation: A Pilot Study. *J Clin Med*. 2021; 10: 1678. DOI: 10.3390/jcm10081678
15. Li J, Chen M, Wei X, Hao Y, Wang J. Evaluation of 3D-Printed Polycaprolactone Scaffolds Coated with Freeze-Dried Platelet-Rich Plasma for Bone Regeneration. *Materials (Basel)*. 2017; 10: 831, DOI:10.3390/ma10070831
16. López-García JS, García-Lozano I, Rivas L, Ramírez N, Méndez MT, Raposo R. Stability of Growth Factors in Autologous Serum Eyedrops After Long-Term Storage. *Curr Eye Res*. 2016; 41:292–298. DOI: 10.3109/02713683.2015.1016180
17. Marx RE. Platelet-Rich Plasma (PRP): What Is PRP and What Is Not PRP?: *Implant Dentistry*. 2001; 10: 225–228. DOI: 10.1097/00008505-200110000-00002
18. Moore GW, Maloney JC, Archer RA, Brown KL, Mayger K, et al. Platelet-Rich Plasma for Tissue Regeneration Can Be Stored at Room Temperature for at Least Five Days. *Br J Biomed Sci*. 2017; 74: 71–77. DOI: 10.1080/09674845.2016.1233792.
19. Murphy S, Gardner FH. Effect of Storage Temperature on Maintenance of Platelet Viability--Deleterious Effect of Refrigerated Storage. *N Engl J Med*. 1969; 280: 1094–1098. DOI: 10.1056/NEJM196905152802004
20. Murphy S, Gardner FH. Platelet Storage at 22°C; Metabolic, Morphologic, and Functional Studies. *J Clin Invest*. 1971; 50: 370–377. DOI: 10.1172/JCI106504
21. Pan L, Yong Z, Yuk KS, Hoon KY, Yuedong S, Xu J. Growth Factor Release from Lyophilized Porcine Platelet-Rich Plasma: Quantitative Analysis and Implications for Clinical Applications. *Aesthetic Plast Surg*. 2016; 40: 157–163. DOI: 10.1007/s00266-015-0580-y
22. Pietramaggiore G, Kaipainen A, Czczuga JM, Wagner CT, Orgill DP. Freeze-Dried Platelet-Rich Plasma Shows Beneficial Healing Properties in Chronic Wounds. *Wound Repair Regen*. 2006; 14: 573–580. DOI:10.1111/j.1743-6109.2006.00164.x
23. Rinder HM, Murphy M, Mitchell JG, Stocks J, Ault KA, Hillman RS. Progressive Platelet Activation with Storage: Evidence for Shortened Survival of Activated Platelets after Transfusion. *Transfusion*. 1991; 31: 409-414. DOI: 10.1046/j.1537-2995.1991.31591263195.x
24. Roffi A, Filardo G, Assirelli E, Cavallo C, Cenacchi A, Facchini A, et al. Does Platelet-Rich Plasma Freeze-Thawing Influence Growth Factor Release and Their Effects on Chondrocytes and Synoviocytes? *Biomed Res Int*. 2014; 2014: 692913. DOI: 10.1155/2014/692913
25. Sandgren P, Shanwell A, Gulliksson H. Storage of Buffy Coat-Derived Platelets in Additive Solutions: In Vitro Effects of Storage at 4 Degrees C. *Transfusion*. 2006; 46: 828–834. DOI: 10.1111/j.1537-2995.2006.00803.x
26. Seghatchian J, Krailadsiri P. Platelet Storage Lesion and Apoptosis: Are They Related? *Transfus Apher Sci*. 2001; 24: 103–105. DOI: 10.1016/s0955-3886(00)00134-x
27. Shiga Y, Orita S, Kubota G, Kamoda H, Yamashita M, et al. Freeze-Dried Platelet-Rich Plasma Accelerates Bone Union with Adequate Rigidity in Posterolateral Lumbar Fusion Surgery Model in Rats. *Sci Rep*. 2016; 6: 36715. DOI: 10.1038/srep36715
28. Shranjevanje in Ravnanje Available online: <http://www.ztm.si/krvni-pripravki/komponente-krvi/shranjevanje-in-ravnanje/> (accessed on 24 October 2022).
29. Steiner N, Vozel D, Urbančič J, Božič D, Kralj-Iglič V, Battelino S. Clinical Implementation of Platelet- and Extracellular Vesicle-Rich Product Preparation Protocols. *Tissue Engineering Part A*. 2022; DOI: 10.1089/ten.tea.2022.0024



30. Tao SC, Guo SC, Zhang CQ. Platelet-Derived Extracellular Vesicles: An Emerging Therapeutic Approach. *Int J Biol Sci.* 2017; 13: 828–834. DOI: 10.7150/ijbs.19776
31. Vozel D, Uršič B, Krek JL, Štukelj R, Kralj-Iglič V. Applicability of Extracellular Vesicles in Clinical Studies. *Eur J Clin Invest.* 2017; 47: 305–313. DOI: 10.1111/eci.12733
32. Vozel D, Božič D, Jeran M, Jan Z, Pajnič M, Pađen L, Steiner N, Kralj-Iglič V, Battelino S. Autologous Platelet- and Extracellular Vesicle-Rich Plasma Is an Effective Treatment Modality for Chronic Postoperative Temporal Bone Cavity Inflammation: Randomized Controlled Clinical Trial. *Front Bioeng Biotechnol.* 2021; 9: 677541. DOI: 10.3389/fbioe.2021.677541
33. Waters L, Cameron M, Padula MP, Marks DC, Johnson L. Refrigeration, Cryopreservation and Pathogen Inactivation: An Updated Perspective on Platelet Storage Conditions. *Vox Sanguinis.* 2018; 113: 317–328. DOI: 10.1111/vox.12640
34. Wen YH, Lin WY, Lin CJ, Sun YC, Chang PY, et al. Sustained or Higher Levels of Growth Factors in Platelet-Rich Plasma during 7-Day Storage. *Clinica Chimica Acta.* 2018; 483: 89–93. DOI: 10.1016/j.cca.2018.04.027
35. Wilson BH, Cole BJ, Goodale MB, Fortier LA. Short-Term Storage of Platelet-Rich Plasma at Room Temperature Does Not Affect Growth Factor or Catabolic Cytokine Concentration. *Am J Orthop (Belle Mead NJ).* 2018; 47. DOI: 10.12788/ajo.2018.0022
36. Wolker WF, Walker NJ, Tamari Y, Tablin F, Crowe JH. Towards a Clinical Application of Freeze-Dried Human Platelets. *Cell Preservation Technology.* 2002; 1: 175–188, DOI: 10.1089/153834402765035617
37. Wood B, Padula MP, Marks DC, Johnson L. Refrigerated Storage of Platelets Initiates Changes in Platelet Surface Marker Expression and Localization of Intracellular Proteins. *Transfusion.* 2016; 56: 2548–2559. DOI: 10.1111/trf.13723

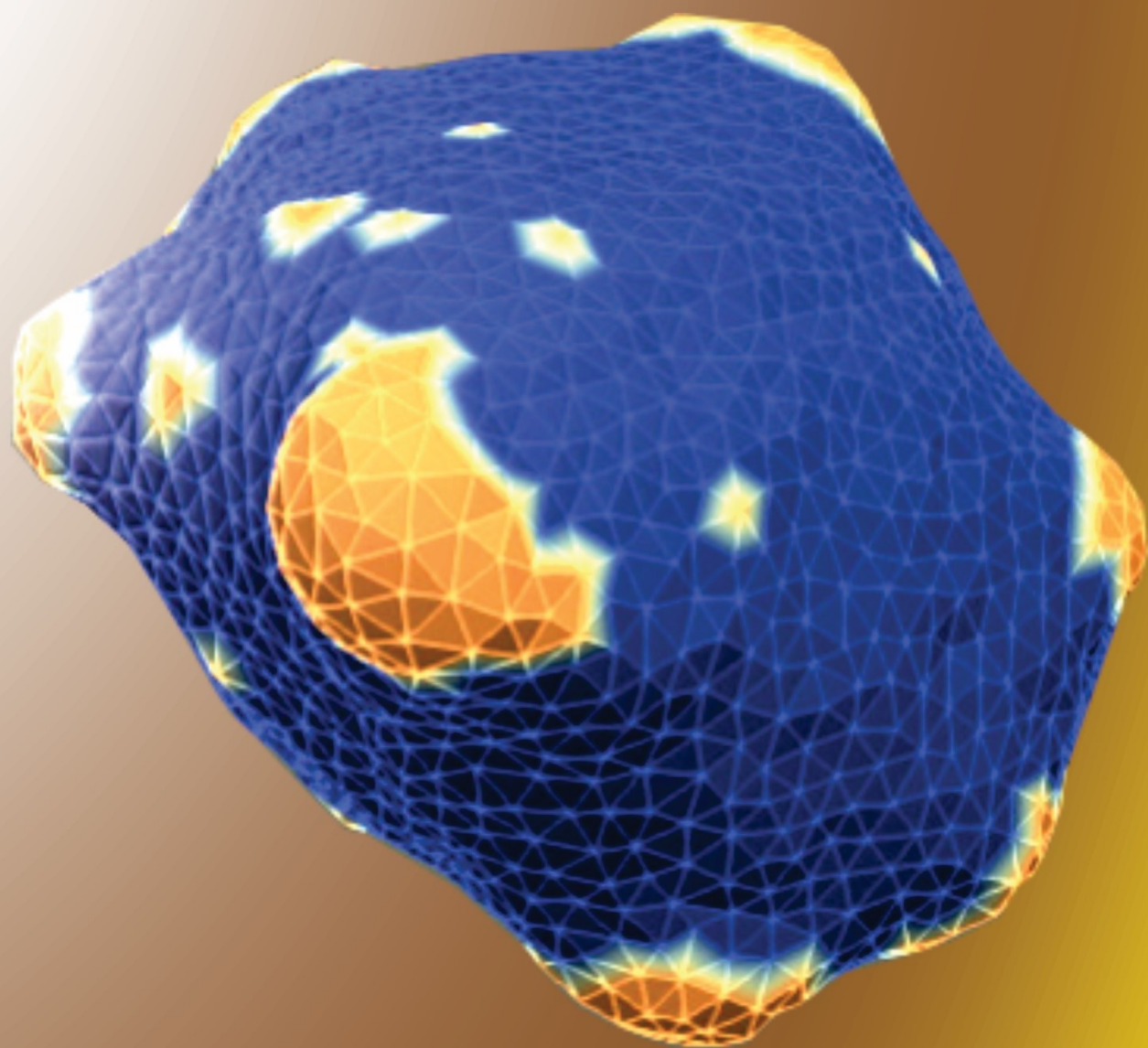



Invited lecture/Scientific contribution

Assessment of Oral Health Status among Medical Students in Georgia

Samkharadze Sophio^{1*}, Zurmukhtashvili Marika¹, Kokhreidze Eka^{1,2}, Kharashvili Elene¹, Beriashvili Sesili¹

¹ European University, Tbilisi, Georgia

² National Centre for Tuberculosis and Lung diseases (NCTLD), Tbilisi, Georgia

* Correspondence: Sophio Samkharadze; sopho.samkharadze@eu.edu.ge

Citation: Samkharadze S, Zurmukhtashvili M, Kokhreidze E, Kharashvili E, Beriashvili S. Assessment of Oral Health Status among Medical Students in Georgia. Proceedings of Socratic Lectures. 2023, 8; 23-27. <https://doi.org/10.55295/PSL.2023.II4>

Publisher's Note: UL ZF stays neutral with regard to jurisdictional claims in published maps and institutional affiliations.



Copyright: © 2023 by the authors. Submitted for possible open access publication under the terms and conditions of the Creative Commons Attribution (CC BY) license (<https://creativecommons.org/licenses/by/4.0/>).

Abstract:

Oral health is considered as important part of general health. Dental caries and periodontal diseases are among most prevalent diseases worldwide. According to WHO oral diseases affect nearly 3.5 billion people and untreated dental caries is the most common health condition. Young adults may neglect oral health. The aim of our study was to evaluate oral health status (dental caries and periodontal diseases) among medical students at European University affiliated dental clinics in Georgia. Simple random sampling method was used. Assessment was conducted using modified WHO Oral Health Assessment Form (2013). Study sample were medical undergraduate students aged between 17 and 25 years at the European University - affiliated dental clinics, Tbilisi, Georgia. Level of dental caries was evaluated by assessment of decayed, missing, and filled teeth scores (DMFT index), while periodontal status was assessed using Community Periodontal Index (CPI) modified index. Statistical analysis of data was performed.

Results: Totally 225 students (150 males and 75 females) originally from Georgia, Jordan, Iran, Egypt, Great Britain and Sweden were included in the study. Mean age of participants was 20.7 years. Mean DMFT score in males was 3.11 and in females it was 3.25; overall mean DMFT was 3.18. Percentage of all individuals in two groups with dental caries (DFT ≥ 1) was 84%. Mean CPI index was 0.82 in males and 0.75 in females. Mean DMFT were compared to National estimates for DMFT index for same age group in developed countries.

Conclusion: Study showed medium prevalence of caries and low prevalence of periodontal diseases in participant students.

Keywords: Oral health, DMFT index, CPI index



1. Introduction

Oral health is considered an important part of general health. Dental caries and periodontal diseases are among the most prevalent diseases worldwide. According to WHO, oral diseases affect nearly 3.5 billion people and untreated dental caries is the most common health condition (WHO, 2022). As a result of studies conducted between 1990 and 2010, untreated dental caries is the most common disease among 291 diseases (Marcenes et al., 2013). The global burden of oral diseases is similar to that of non-communicable diseases such as cardiovascular disease, schizophrenia and/or hemolytic anemia. According to epidemiological data, the prevalence of caries has decreased over the past four decades, but mainly in high-income countries, with the most significant decrease observed in children aged 12 years (Frencken et al., 2017). Another 2019 study revealed that the prevalence of dental diseases is much higher than expected, and the prevalence of caries in children is 79.1% (Ballouk and Dashash, 2019).

It is also estimated that 5-20% of the world's population has gum disease (Petersen and Ogawa, 2012). According to the Global Burden of Disease study, acute periodontitis was the 11th most common disease worldwide (GBD, 2017). Periodontal diseases affect 20 to 50% of the world's population (Sanzet al., 2010). This is one of the main causes of tooth loss which negatively affects chewing function, aesthetics, self-confidence and quality of life (Tonetti et al., 2017). In the period from 1990 to 2010 morbidity increased by 57.3%. The highest incidence rate of chronic periodontitis was observed in the elderly population (82%), followed by adults (73%) and finally adolescents (59%) (Tadjoedin et al., 2017).

In young adults oral health can be neglected. Adolescence and young adulthood is considered as a period of life when individual oral health behaviors are internalized and formed as habits (Stokes et al., 2006). Therefore, individuals from this age group may be subjected to greater risk for development of dental diseases during a period when they are just establishing oral care habits (Coolidge et al., 2009). Study by Skaret E et al. (1999) demonstrated that individuals who avoid regular dental visits have significantly more caries compared to their peers. In particular 16.4% of those who failed to visit the dentist had decayed, missing, and filled teeth (DMFT) scores more than one standard deviation above the mean for the same age group (Skaret et al., 1999). The aim of our study was to evaluate oral health status (dental caries and periodontal diseases) among medical students at European University affiliated dental clinics in Georgia.

2. Materials and methods

Study sample were medical undergraduate students of the Medical Faculty, European University, Tbilisi, Georgia. Male and female individuals aged between 17 and 25 years with different nationalities were included in the study. For population surveys WHO recommends to evaluate 12, 15 and 35-44 years age groups. But since the aim of our study was to evaluate the oral health condition of undergraduate students, a relevant age group between 17-25 years was selected. Simple random sampling method was used. Evaluation process was conducted at two dental clinics in Tbilisi, Georgia, which are affiliated to European University. Data collection was performed during 3 weeks in October and November 2022. Assessment was conducted using modified WHO Oral Health Assessment Form (2013) and following protocols recommended by WHO for oral health surveys (WHO, 2013). Level of dental caries was evaluated using decayed, missing, and filled teeth scores (DMFT index), while periodontal status was assessed using CPI modified index. The examination for dental caries was performed with a plane mouth mirror. Permanent dentition status was recorded in Oral Health Assessment Form using numbered scores. Decayed, Missing and Filled Teeth Index (DMFT) was calculated using the recorded data. The level of caries experience in the permanent dentition was evaluated according to the WHO severity criteria (Petersen, 2003) (Table 1).



Table 1. Level of caries experience in the permanent dentition according to the WHO severity criteria

Severity	Children 12 years of age	Adults 35–44 years of age
Very low	< 1.2	< 5.0
Low	1.2 – 2.6	5.0 – 8.9
Moderate	2.7 – 4.4	9.0 – 13.9
High	4.5 – 6.5	> 13.9
Very high	> 6.5	

The periodontal status was evaluated using a modified Community Periodontal Index (CPI). For evaluation a special periodontal probe with 0.5 mm ball tip is used which has black band markers at 3.5, 5.5, 8.5 and 11.5 mm. Totally 10 teeth in each individual were assessed i.e. 17, 16, 11, 26, 27, 37, 36, 31, 46 and 47 and following clinical parameters has been checked: gingival bleeding, supra- and subgingival calculus, periodontal pockets with probing depths between 3.5–6.0 mm, as well as clinical attachment loss. Data were recorded in the same Oral Health Assessment Form.

The research project was approved by the Ethics and Research Committee of the Faculty of Medicine of European University. All participants were previously informed about the study, informed consent from each participant has been obtained and the confidentiality of the information provided was guaranteed.

3. Results

A total of 225 students aged 17 to 25 years participated in present study. Mean age of participants was 20.7 years. Majority of examined individuals were males - 66.67%; From total number of participants 26% were originally from Georgia, 35.77% - from Jordan, 17.78%- from Iran, 11.56% - from Egypt, 6.67 % - from Great Britain and 2.22% - from Sweden. As a reference, the mean values between 12 years group and 35-44 years' group as given in **Table 1** were considered for our study age group. Accordingly, DMFT: very low < 3.1, low 3.1 – 5.75, moderate 5.75 - 9.15, high – more than 9.15. Distribution of participants (males and females) over the DMFT values is presented in **Figure 1**.

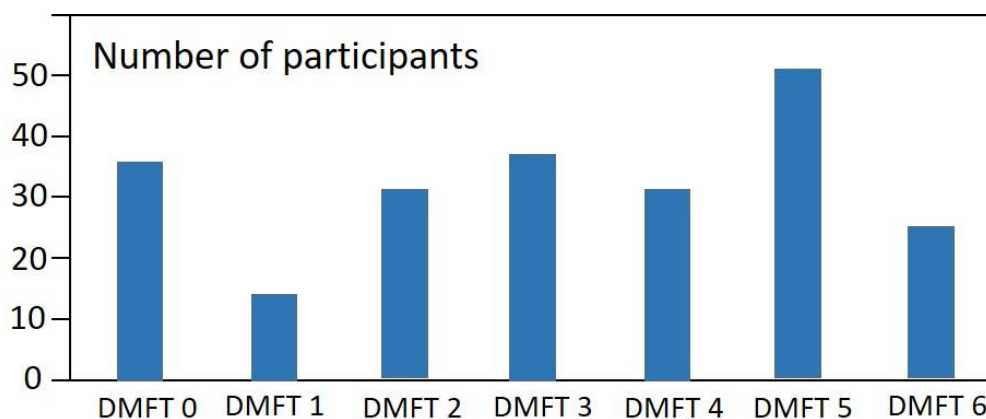

Figure 1. Distribution of participants according to DMFT values



Majority (80%) of participants had very low or low severity of caries. Mean DMFT scores in males was 3.11 and in females- 3.25; Overall mean DMFT in two gender groups was 3.18. Percentage of all individuals in two groups with dental caries (DFT \geq 1) was 84%. Mean CPI index was 0.82 in males and 0.75 in females respectively. The mean CPI index for both groups was 0.79. Distribution of participants (males and females) according to CPI values is presented in **Figure 2**

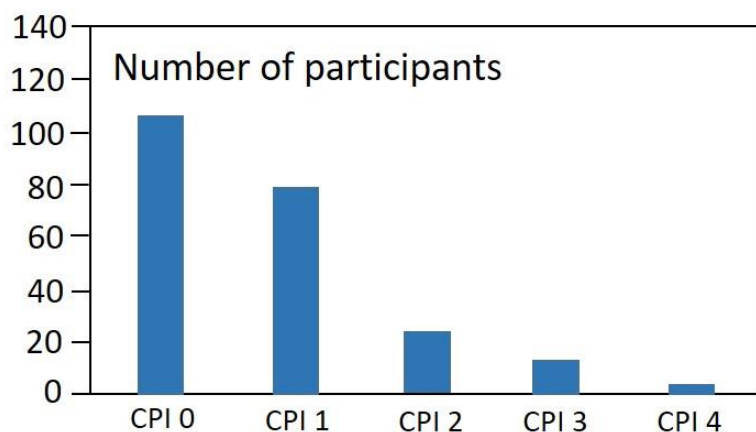

Figure 2. Distribution of participants according to CPI values

4. Discussion

Despite the measures taken in recent years, oral and dental health in some special groups of population can be alarming. From this point of view the oral health condition in undergraduate students' social group can be of great interest for scientists and dental professionals. In recent years there are some surveys done for different groups of Georgian population but our study was the first in recent years to evaluate the undergraduate student groups including foreign students. In this study we have assessed the oral health status of undergraduate medical students in Tbilisi. Our study demonstrated that DMFT index values for male as well as for female participants can be described as "low", while another study in children in Georgia by Vashakidze and Jikia (2021) demonstrated high and very high intensity of caries in children in Georgia. In terms of prevalence, our results were consistent with the results of research by Vashakidze and Jikia (2021). Both studies demonstrated high prevalence of caries in children (98.8%) as well as in students (84%). We have compared the mean DMFT value to National estimates for the DMFT index for the same age group in developed countries. In Germany, the mean DMFT index for the age group 15 years was 1.4, in the UK – 2.05 and in Sweden – 2.19. The DMFT index demonstrated in our study is still higher than in developed countries. Oral and dental health can be improved by influencing and enhancing behavioral habits specially for individual oral hygiene, by improving socioeconomic status and by increasing individual access to health insurance. During our research we have not assessed oral hygiene and also have not evaluated participants' oral hygiene knowledge and habits. The lack of this information can be considered as a limitation of our study. Further research is needed to perform statistical analysis of data and comparison between different groups.

Conflicts of Interest: The authors declare no conflict of interest.

**References:**

1. Ballouk MA, Dashash M. Caries prevalence and dental health of 8-12 year-old children in Damascus city in Syria during the Syrian Crisis; a cross-sectional epidemiological oral health survey. *BMC Oral Health*. 2019; 19: 16. DOI: 10.1186/s12903-019-0713-9
2. Coolidge T, Heima M, Johnson EK, Weinstein P. The Dental Neglect Scale in adolescents. *BMC Oral Health*. 2009; 9: 2. DOI:10.1186/1472-6831-9-2
3. GBD 2017 Disease and Injury Incidence and Prevalence Collaborators. Global, regional, and national incidence, prevalence, and years lived with disability for 354 diseases and injuries for 195 countries and territories, 1990-2017: a systematic analysis for the Global Burden of Disease Study 2017 [published correction appears in *Lancet*. 2019 Jun 22; 393: e44]. *Lancet*. 2018; 392: 1789-1858. DOI:10.1016/S0140-6736(18)32279-7
4. Frencken JE, Sharma P, Stenhouse L, Green D, Laverty D, Dietrich T. Global epidemiology of dental caries and severe periodontitis - a comprehensive review. *J Clin Periodontol*. 2017; 44 Suppl 18:S94-S105. DOI:10.1111/jcpe.12677
5. Marcenes W, Kassebaum NJ, Bernabé E, et al. Global burden of oral conditions in 1990-2010: a systematic analysis. *J Dent Res*. 2013; 92: 592-597. DOI:10.1177/0022034513490168
7. Petersen PE. The World Oral Health Report 2003: continuous improvement of oral health in the 21st century--the approach of the WHO Global Oral Health Programme. *Community Dent Oral Epidemiol*. 2003; 31 Suppl 1: 3-23. DOI: 10.1046/j.2003.com122.x
8. Petersen PE, Ogawa H. The global burden of periodontal disease: towards integration with chronic disease prevention and control. *Periodontol 2000*. 2012; 60: 15-39. DOI: 10.1111/j.1600-0757.2011.00425.x
9. Sanz M, D'Aiuto F, Deanfield J, Fernandez-Aviles F. European workshop in periodontal health and cardiovascular disease-scientific evidence on the association between periodontal and cardiovascular disease: a review of the literature. *Eur Heart J Supplements*. 2010; 12: 3-12. DOI: <https://doi.org/10.1093/eurheartj/suq003>
10. Skaret E, Raadal M, Berg E, Kvale G. Dental anxiety and dental avoidance among 12 to 18 year olds in Norway. *Eur J Oral Sci*. 1999; 107: 422-428. DOI: 10.1046/j.0909-8836.1999.eos107602.x
11. Stokes E, Ashcroft A, Platt MJ. Determining Liverpool adolescents' beliefs and attitudes in relation to oral health. *Health Educ Res*. 2006; 21: 192-205. DOI:10.1093/her/cyh055
12. Tadjoeidin FM, Fitri AH, Kuswandani SO, Sulijaya B, Soeroro Y. The correlation between age and periodontal diseases. *Journal of International Dental and Medical Research*. 2017; 10: 327-332.
13. Tonetti MS, Jepsen S, Jin L, Otomo-Corgel J. Impact of the global burden of periodontal diseases on health, nutrition and wellbeing of mankind: A call for global action. *J Clin Periodontol*. 2017; 44: 456-462. DOI: 10.1111/jcpe.12732
14. Vashakidze N, Jikia M. Assessment of oral health conditions in children with different social status in Georgia. *Ind J Appl Research* 2021; 11(12). DOI : 10.36106/ijar/5415289
15. World Health Organization . Oral health surveys: basic methods – 5th ed. Publication 12 November 2013. Accessed 08.10.2022. Available from: <https://www.who.int/publications/i/item/9789240061484>
DOI : 10.36106/ijar/5415289

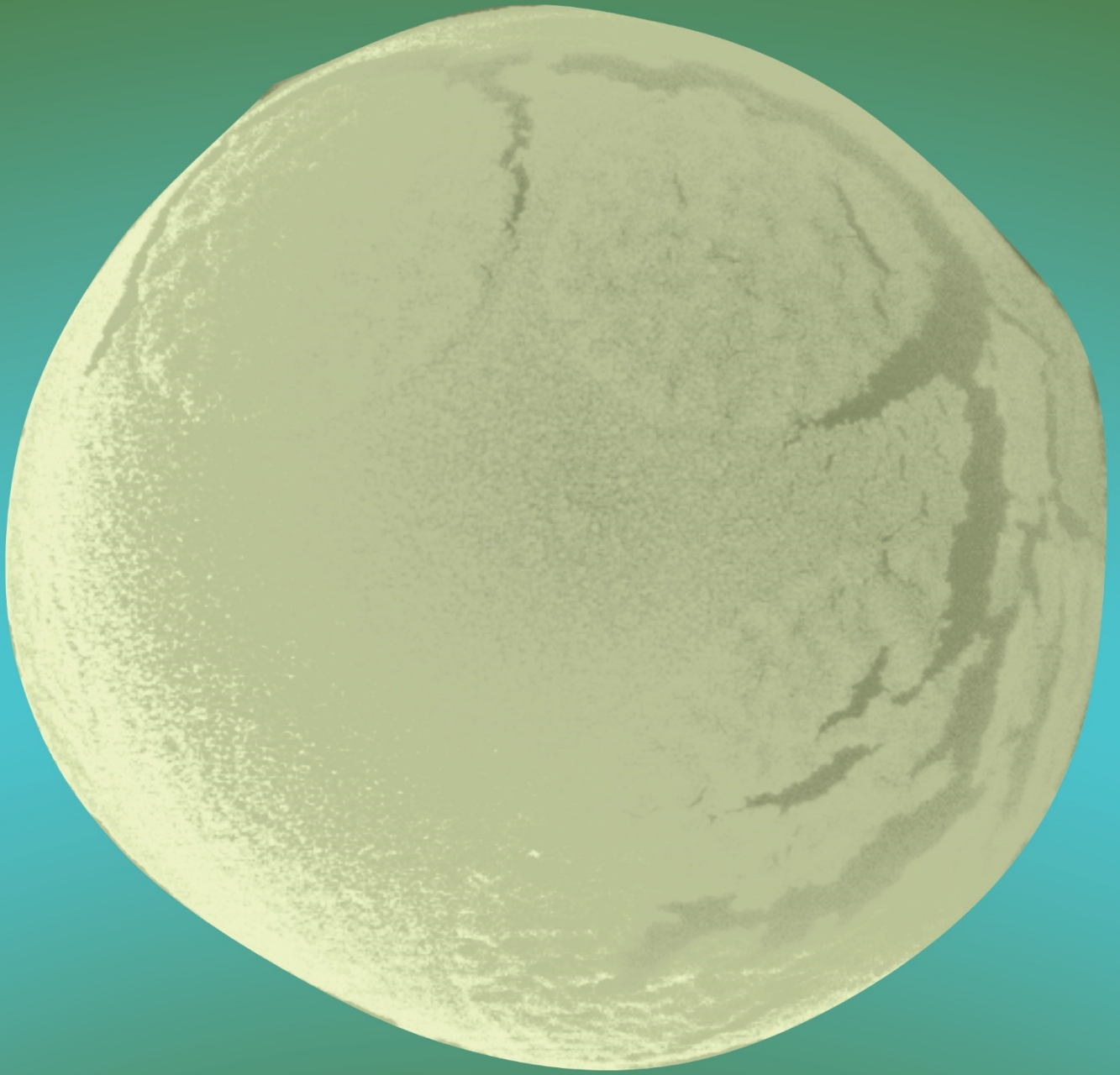



Invited lecture/Scientific contribution

Availability of Dental Services for Medical Students in Georgia

Samkharadze Sophio^{1*}, Zurmukhtashvili Marika¹, Kokhraidze Eka^{1,2}, Kharashvili Elene¹, Beriashvili Sesili¹

¹ European University, Tbilisi, Georgia

² National Centre for Tuberculosis and Lung diseases (NCTLD), Tbilisi, Georgia

* Correspondence: Sophio Samkharadze; sopho.samkharadze@eu.edu.ge

Abstract:

Oral health is important issue in field of public health and can be negatively affected by psycho-emotional factors. Foreign medical students can be subjected to oral disease risk factors and therefore be in significant need for regular dental care, but there is a lack of information how good students access the dental clinics. Study aimed to evaluate the accessibility to dental care for foreign medical students in Georgia. We conducted an online survey in duration of two weeks in October – November 2022. Study sample were medical undergraduate students, they answered 12 questions about frequency and type of dental visits, about availability and quality of dental care they received in Georgia. Overall from 270 medical undergraduate students aged between 18-45 years, 70% were male and 30% female. 70% were from Jordan, Iran - 15%, Egypt - 4%; Great Britain - 4%, France - 4% and Rwanda - 4%. In their countries 50% of students used to visit dental clinics every 6 months for regular check-up (70%); professional cleaning (31%) and dental pain (27%). 81.48% of interviewed students have never visited a dental clinic in Georgia. Among them who visited, the purpose was check-up (65%) and dental pain (30%). For the source of information about dental clinics the students named internet (60%). Access to dental care was rated as medium (37.50%), while overall satisfaction was rated as normal (47.62%). The study showed very low rate of referral to the dentist. However, among those who visited the clinic, their evaluations were satisfactory. We can estimate the lack of information as an important barrier for students. In addition, some students arrived in Georgia only a few months before the study started, so there might be no need to visit dentist in the time interval studied. Further research is needed to clearly identify possible barriers for dental care for medical students.

Citation: Samkharadze S, Zurmukhtashvili M, Kokhraidze E, Kharashvili E, Beriashvili S. Availability of Dental Services for Medical Students in Georgia. Proceedings of Socratic Lectures. 2023, 8; 29-32.
<https://doi.org/10.55295/PSL.2023.II5>

Publisher's Note: UL ZF stays neutral with regard to jurisdictional claims published maps and institutional affiliations.



Copyright: © 2023 by the author. Submitted for possible open access publication under the terms and conditions of the Creative Commons Attribution (CC BY) license (<https://creativecommons.org/licenses/by/4.0/>).

Keywords: Oral health; Dental care; Accessibility of dental care; Medical students



1. Introduction

Oral health is an important issue in the field of public health. Despite the successes in the field dental diseases remain an acute and urgent problem in the world, especially among the poor and underprivileged groups of the world population, both in developed and developing countries (WHO, 2022). The most common dental diseases are dental caries and periodontal diseases. These diseases are multifactorial and their development is influenced by many local and general risk factors (Kazeminia et al., 2020). Dental care is one of the most expensive medical services and is rarely covered by insurance companies. Worldwide, reimbursement for dental services varies according to regional or country health policies (Alemayehu and Warner, 2004).

Oral diseases are negatively affected by psycho-emotional factors. It is known that chronic stress can contribute to progression and even development of oral diseases in two different ways. Individuals subjected to chronic stress are more prone to lead unhealthy lifestyle, to substance abuse, drugs, tobacco and alcohol misuse. They also can neglect oral hygiene. In addition chronic stress contributes to development of dysfunction of physiological systems critical to homeostasis and thus affects key mechanisms of disease progression in general (Vasiliou et al., 2016).

Socioeconomic factors are well known to have influence on overall oral health and can be one of the reasons for demonstrated inequalities in oral health outcomes. Several authors suggest that when compared to other common social groups, individuals from vulnerable and disadvantaged groups are less likely to have dental insurance. Due to this fact they are more likely to visit a dentist only in case of acute emergency and avoid routine dental visits due to high cost (Borenstein et al., 2013).

Foreign medical students can be considered as individuals subjected to chronic stress and oral disease risk factors and therefore be in significant need for regular dental care. But due to high costs of dental services students are also less likely to apply for routine dental visits. But there is a lack of information on how good students access the dental clinics and if high quality dental care in Georgia is affordable for them. Therefore, our study aimed to evaluate the accessibility to dental care for foreign medical students in Georgia.

2. Materials and Methods

This study was conducted using online survey. Data collection was performed during 2 weeks in October and November 2022. Study sample were undergraduate students of Medical Faculty of European University enrolled in english language Dentistry program. The university is located in the capital of Georgia – Tbilisi and in Fall semester 2022-2023 has 944 students enrolled in the Dentistry program. Main inclusion criteria were citizenship of foreign country and residency in Georgia for more than 6 months

The data were collected by an online survey, which was created using AL-powered online platform SurveyMonkey. A Total of 12 questions were included in the online questionnaire. To verify possible associated social and demographic factors participants were asked to specify their gender, age and nationality. To identify changes in frequency and types of dental services after arrival in Georgia, participants were asked separate questions about frequency and purpose of dental visits in their home country and in Georgia. To evaluate the availability of information about dental clinics in Georgia participants have been asked to specify the way they get information about dental clinics in Tbilisi. The accessibility of dental services for students was evaluated by direct question “How would you rate the access to the service”. At the end participants also were asked to leave any additional comments about their experience regarding receiving dental treatment in Georgia.

The research project and questionnaire was approved by the Ethics and Research Committee of the Faculty of Medicine of European University. All participants were previously informed about the study and the confidentiality of the information provided was guaranteed.



3. Results

Totally 270 undergraduate students participated in study. The age range was from 18 to 45 years, 70% were male and 30% female; Main foreign home countries for students were: 70% Jordan, Iran - 15%, Egypt - 4%; Great Britain - 4%, France - 4%, Rwanda - 4% (Figure 1).

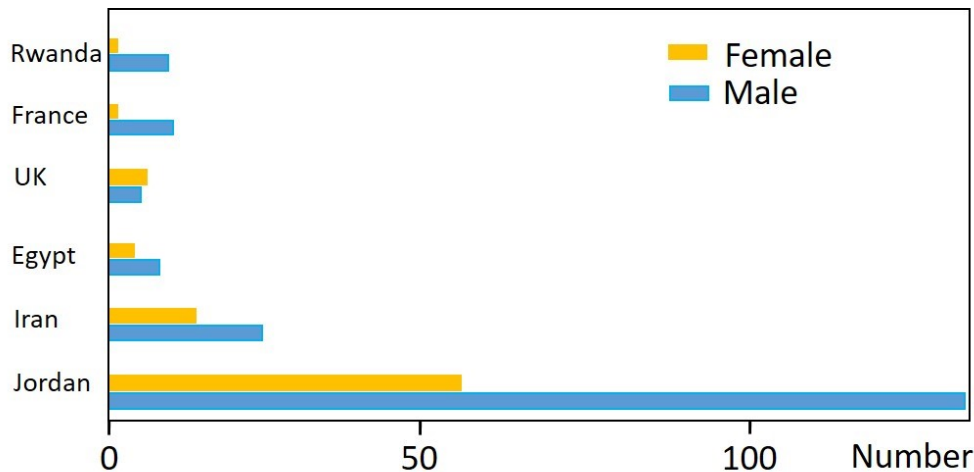

Figure 1. Distribution of participants according to gender and home country

In their countries 50% of students used to visit dental clinics every 6 months. For the question about the purpose of visit participants had multiple options for choice. Regular check-up was named in 70%, professional cleaning visit in- 31%, dental pain - in 27%, dental caries in 20%. Further reasons for dental visits such as root canal treatment, tooth extraction, orthodontic treatment and prosthetic treatment were named in less than 10%. Same questions were asked about dental service in Georgia. 81.48% of interviewed students have never visited a dental clinic in Georgia. Among them who visited, main purpose were check-up (65%) and dental pain (30%) (Table 1).

Table 1. Main reasons for dental visits in home country and in Georgia.

Purpose of dental visit	In home country (%)	In Georgia (%)
Regular check-up	70	65
Professional cleaning	31	30
Dental pain	27	32
Dental caries	20	16
Root canal treatment	9	4
Tooth extraction	6	4
Orthodontic treatment	9	12
Prosthetic treatment	3	8

As the source of information about dental clinics, the students named the internet (60%). Also they get information from their friends (28%) and lecturers (20%). University was named as a source of information only in 10 % of cases.

Access to dental care was rated as easy by 37.93% of participants, as not so easy by 17.24%, medium by 37.93% and difficult or too difficult by less than 7 %.



Overall satisfaction from nearly half of participants was rated as “normal” (47.62%). 34.6 % of students were “satisfied” with dental service provided in Georgia, while 15.08 % were “very satisfied”. Only 2.7 % of participants described the service as “very bad”.

Most participants (60%) evaluated the value for money of dental service in Georgia as “average” while 28% of them rated it as “above average” and 8 % as “excellent”. Only 4 % of students assessed value for money as “poor”.

4. Discussion

In recent literature high costs are named as the main barrier to receive dental care (Thompson et al, 2014). Avoiding dental visits and treatment due to high cost is a barrier that exists prior to seeking treatment, while sometimes, when the recommended dental care is costly, after the initial visit, persons reject the recommended care. Both circumstances point to the possibility of progressive dental caries or poor oral health due to cost barriers (Ramraj and Quiñonez, 2013). Our study has demonstrated a low rate of initial referral to the dentist. But from the participants of our study “money for value” evaluation for dental treatment was rated mostly as medium. So we can speculate not to consider high costs as the main reason for low referral. Also among those who visited the clinic, their evaluations were on the average satisfactory. Instead we can estimate the lack of information as an important barrier for students. Since students receive less information about dental services from University than from the internet (10% and 60 % respectively), based on our study we can suggest recommendations for student service centers to promote information about available dental clinics, services and prices in Tbilisi. As the limitation of our study, we found that some students arrived in Georgia only a few months before the study started. To avoid the bias caused by this weakness, only the students who have spent more than 6 months in Georgia were involved in our study. But still, students might not have needed to visit the dentist yet. Further research is needed to clearly identify possible barriers for dental care for medical students.

Conflicts of Interest: The authors declare no conflict of interest.

References:

1. Alemayehu B, Warner KE. The lifetime distribution of health care costs. *Health Serv Res.* 2004; 39: 627-642
DOI:10.1111/j.1475-6773.2004.00248.x
2. Borenstein H, Renahy E, Quiñonez C, O'Campo P. Oral health, oral pain, and visits to the dentist: neighborhood influences among a large diverse urban sample of adults. *J Urban Health.* 2013; 90: 1064-1078.
DOI:10.1007/s11524-013-9802-2
3. Kazemina M, Abdi A, Shohaimi S, Jalali R, et al. Dental caries in primary and permanent teeth in children's worldwide, 1995 to 2019: a systematic review and meta-analysis. *Head Face Med.* 2020; 16: 22.
DOI:10.1186/s13005-020-00237-z
4. Ramraj C, Quiñonez CR. Self-reported cost-prohibitive dental care needs among Canadians. *Int J Dent Hyg.* 2013; 11:115-120. DOI:10.1111/j.1601-5037.2012.00552.x
5. Thompson B, Cooney P, Lawrence H, Ravaghi V, Quiñonez C. The potential oral health impact of cost barriers to dental care: findings from a Canadian population-based study. *BMC Oral Health.* 2014; 14: 78.
DOI:10.1186/1472-6831-14-78
6. Vasiliou A, Shankardass K, Nisenbaum R, Quiñonez C. Current stress and poor oral health. *BMC Oral Health.* 2016; 16: 88. DOI:10.1186/s12903-016-0284-y
7. WHO. Global oral health status report . Geneva. World Health Organization. 2022; accessed: 08.10.2022. Available from: <https://www.who.int/publications/i/item/9789240061484>

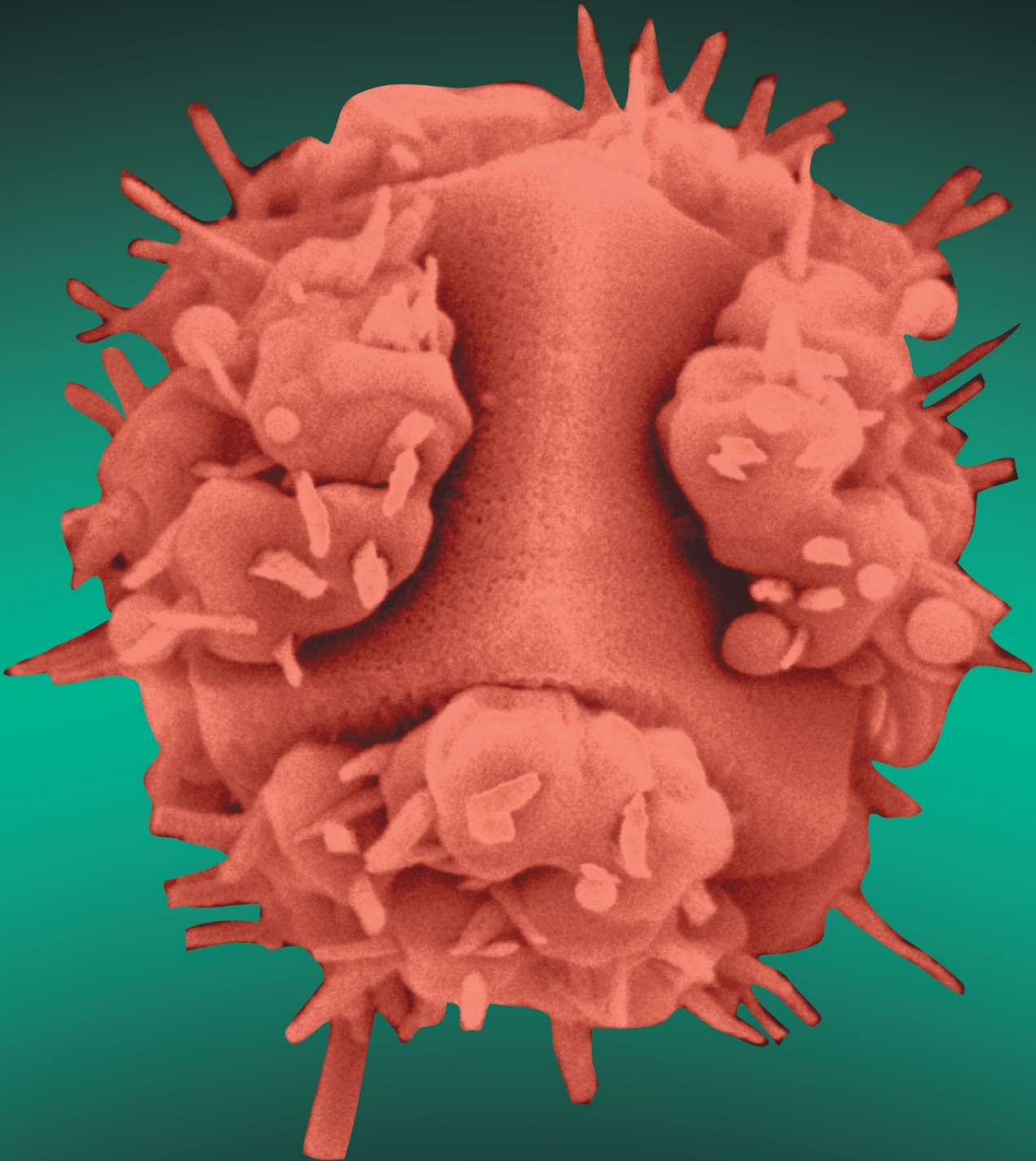

*Invited lecture/Review*

Portosystemic Shunts in Cats

Vladimira Erjavec¹, Barbara Lukanc^{1,*}¹ University of Ljubljana, Veterinary Faculty, Small Animal Clinic, Ljubljana, Slovenia* Correspondence: Barbara Lukanc, barbara.lukanc@vf.uni-lj.si**Abstract:**

The portosystemic shunt (PSS) is an abnormal communicating vessel between the portal and systemic vasculature. The liver is underdeveloped due to decreased blood flow. The PSS may be congenital (intrahepatic or congenital) or acquired (extrahepatic). Ammonia and intestinal toxins are not cleared in the liver, causing various clinical signs of hepatic encephalopathy. Medical treatment is aimed at minimising clinical signs and stabilising the cat prior to surgical treatment. Surgical treatment is currently the method of choice; however, the best method of occluding the shunts has yet to be found. Surgical treatment involves complete ligation of the shunt in cases where the portal vasculature is adequately developed, but more commonly the surgery aims to occlude the shunt gradually with a cellophane banding or ameroid ring. The cellophane may not produce the same fibrotic response as in dogs, so clinical signs often improve, but the cat still requires medication. In general, the prognosis after surgery in cats is not as good as in dogs.

Citation: Erjavec V, Lukanc B. Portosystemic shunts in cats. Proceedings of Socratic Lectures. 2023, 8; 34-39.
<https://doi.org/10.55295/PSL.2023.II6>

Publisher's Note: UL ZF stays neutral with regard to jurisdictional claims in published maps and institutional affiliations.

**Keywords:** Portosystemic shunt; Cats; Neurological signs; Seizures, Cellophane banding

Copyright: © 2023 by the authors. Submitted for possible open access publication under the terms and conditions of the Creative Commons Attribution (CC BY) license (<https://creativecommons.org/licenses/by/4.0/>).

1. Introduction

The portosystemic shunt (PSS) is an abnormal communicating vessel between the portal and systemic vasculature that causes decreased blood flow to the liver, preventing the liver developing normally (Tivers and Lipscomb, 2011). In normal animals, blood from the stomach, intestine, pancreas and spleen is transported to the liver via the portal vein to perfuse the liver, after that the blood enters the hepatic veins, and then the caudal vena cava (Tobias, 2003; Tivers and Lipscomb, 2011). The liver performs many important functions, including the metabolism of toxic or harmful substances absorbed from the gastrointestinal (GI) tract. Proteins that enter the GI tract are degraded by anaerobic and coliform bacteria via urea to ammonia, which is transported to the liver and converted to urea.

Ammonia in cats with PSS is not metabolised by the liver but enters the systemic circulation directly, which is why ammonia is elevated in blood (Tivers and Lipscomb, 2011). Due to decreased oxygenated and nutrient-rich blood supply through the portal vein, the liver is underdeveloped in cats with PSS. Usually, the liver is small (hypoplastic) and has inadequate function. High levels of waste products (such as ammonia and intestinal toxins) are transported directly into the systemic circulation via the shunting vessel (Hottinger et al., 1995), causing various clinical signs related to hepatic encephalopathy and the central nervous system (Lipscomb et al., 2007; Tivers and Lipscomb, 2011). Hepatic encephalopathy can be triggered by high-protein meals, GI bleeding, and anaesthetics (Tivers and Lipscomb, 2011).

PSS can be congenital or acquired. A congenital PSS is an abnormal communicating vessel between the portal and systemic vasculature, they may be intra- or extrahepatic; whereas acquired PSS develop secondary to underlying liver disease (Lipscomb et al., 2007; Tivers and Lipscomb, 2011). The most common forms of PSS in cats are extrahepatic (73–100%) (Birchard and Sherding, 1992; Levy et al., 1995; Lipscomb et al., 2007). Congenital PSS are rare in cats with an incidence of 2.5 per 10,000 cats (Levy et al., 1995). Although Hunt (2004a) stated that there is no association between breed and the type of shunt found in cats, other studies suggest that extrahepatic PSS most commonly affects domestic shorthair cats, followed by Persian, British shorthair, ragdoll, domestic longhair, Birman, British blue, and Tonkinese, whereas intrahepatic PSS most commonly affects Siamese cats. In terms of gender male cats are most affected (Lipscomb et al., 2007).

2. Clinical manifestation



Cats with PSS present with nonspecific clinical signs that are typically episodic and worsen after feeding (Lipscomb et al., 2007; Tivers and Lipscomb, 2011). Cats may present with hypersalivation and neurological signs such as ataxia, head pressing, strange behaviour, lethargy, aggression, tremors, blindness, and seizures. Cats may be small, the body condition score (BCS) may be low, but even a normal BCS does not rule out PSS. Some cats have a copper-coloured irises (**Figure 1**). Gastrointestinal signs such as anorexia, vomiting and diarrhoea have been noted, and urinary signs (dysuria, haematuria) due to ammonium urate urolithiasis may also be observed (Lipscomb et al., 2007). Due to impaired metabolism in the liver, cats may require a longer recovery time after anaesthesia (Tivers and Lipscomb, 2011).

Figure 1. Copper coloured irises in a cat with PSS.



3. Diagnosis

The diagnosis of PSS can be made based on laboratory findings such as routine haematology and biochemistry, urinalysis – ammonium biurate crystals (Kyles, et al.2002), abdominal ultrasound, computed tomography (CT), MRI, and nuclear scintigraphy (Tivers and Lipscomb, 2011). Biochemical changes, such as decreased urea concentrations in blood can be seen in cats with PSS when more than 70% of liver function have been lost and decreased creatinine in blood can also be seen in cats with low muscle mass (Kyles et al., 2002; Tobias, 2003). Alkaline phosphatase (ALP) and alanine aminotransferase (ALT) in blood are normal or may be moderately elevated (cite). Albumins are usually not decreased as it is common in dogs (Kyles et al., 2002).

CT angiography is the gold standard for diagnosing PSS in cats and provides highly detailed information about shunt morphology and the hepatic vasculature (Zwingenberger, 2009). The final diagnosis is made at the time of surgery (Tivers and Lipscomb, 2011). Hepatic function can be assessed by bile acids and ammonia blood testing. Postprandial bile acids in blood have a sensitivity of 100% and fasting bile acids in blood have a specificity of 84% and both have the best predictive values for the diagnosis of PSS in cats (Center et al., 1995). Fasting ammonia, with a sensitivity of 83% and a specificity of 86% is elevated in most cats with PSS (Ruland et. al., 2010).

4. Treatment options

Medical treatment of cats with PSS is indicated to minimise clinical signs, to stabilise the cat before surgical treatment, or when surgery is not possible because of the location of the shunt. Medical treatment is important to decrease the absorption of ammonia and toxic products from the gastrointestinal tract and to prevent hepatic encephalopathy (Broome et al., 2004) and consists of lactulose, low-protein diet, oral antibiotics, and anticonvulsants. Oral administration of antibiotics (ampicillin 10 - 20 mg/kg/8h or metronidazole 10 mg/kg/12h) reduces the gastrointestinal population of ammonia-producing anaerobic and Gram-negative bacteria. Lactulose (0.5 - 2 ml/8 - 12h, orally) reduces ammonia production and absorption. To lower protein intake, cats should be fed a commercial diet with low to moderate protein content (Tivers and Lipscomb, 2011). For cats, which have higher protein requirements than dogs, commercial liver support diets with moderate amounts of high-quality protein are recommended. Vegetable protein sources are not recommended for cats (Lidbury et al., 2016).

Cats suffering from seizures should receive phenobarbitone (1 - 4 mg/kg orally/12 h), propofol infusion (0.05-0.4 mg/kg/min) and levetiracetam (20 mg/kg/intravenously (IV)). Acid-base status, dehydration, glucose, coagulation profiles, and electrolytes in blood should be corrected as needed (Tivers and Lipscomb, 2011; Tonge, 2021). Vitamin K should be administered 1 - 2 days before surgery when coagulation profiles are prolonged (Self, 2016). If gastrointestinal bleeding is suspected, gastroprotective drugs should be administered (Lidbury et al., 2016).

5. Anaesthesia

Cats should be fasting 3 - 4 hours before anaesthesia, and blood glucose levels should be monitored throughout the perioperative period. Methadone 0.1 - 0.2 mg/kg intramuscularly (IM) or IV as premedication provides intraoperative as well as postoperative analgesia (Tonge, 2021). Remifentanyl 5 - 40 µg/kg/h IV or fentanyl 5 - 8 µg/kg/h IV should be administered as a constant rate infusion during surgery (Day, 2013; Self, 2016). If sedation with an opioid alone is not sufficient, a low dose of medetomidine 0.5-3 µg/kg IM or dexmedetomidine 0.5 - 1.5 µg/kg IV or IM can be administered. Alpha-2 receptor agonists such as medetomidine and dexmedetomidine are reliable sedatives that reduce the drug doses required for induction and maintenance of anaesthesia and also contribute to analgesia (Lemke, 2004; Murrell and Hellebrekers, 2005). Acepromazine should not be used in patients with PSS because it can lead to an excessively long duration of action and prolonged hypotension and has no reversal agent (Murrell, 2016).

Propofol or alfaxalone are commonly used for IV induction of anaesthesia (Self, 2016). Maintenance of anaesthesia with isoflurane or sevoflurane reduces the risk of potential drug accumulation (Day, 2013; Self, 2016). Isoflurane or sevoflurane can cause dose-dependent hypotension (Bernard et al., 1992). During anaesthesia, IV Ringer's lactate should



be administered at a rate of 3 ml/kg/h (Davis et al., 2013), and in the event of hypotension, a bolus of hydroxyethyl starch (3 ml/kg) should be administered and repeated after 15 minutes if needed (Day, 2013). Monitoring during anaesthesia is important to assess depth of anaesthesia and cardiorespiratory function.

This includes pulse oximetry, end-tidal carbon dioxide concentration, isoflurane concentration, non-invasive arterial blood pressure measurement with Doppler, electrocardiogram, and temperature (Day, 2013). It is also important to monitor palpebral reflexes, eye position, pulse rate and quality, and respiratory rate and depth (Tonge, 2021).

Repeated administration of opioids after surgery should be based on objective pain scales, with an established intervention value rather than predetermined dosing intervals (Tonge, 2021). If seizures occur during recovery, they should be treated with an IV infusion of propofol (Heldman et al., 1999) and/or with levetiracetam (20 mg/kg IV) or phenobarbitone (2 - 3 mg/kg IV) (Tivers and Lipscomb, 2011). The use of benzodiazepines is not recommended in patients with PSS (Self, 2016). Non-steroidal anti-inflammatory drugs are contraindicated due to liver disease. Medical treatment should be continued for at least two weeks after surgery.

6. Surgical treatment

Surgical treatment consists of complete or partial closure of the shunt. Some authors (Youmans and Hunt, 1998) recommend slow occlusion to reduce the risk of life-threatening portal hypertension. This can be done with an ameroid ring or cellophane band (Vogt et al., 1996; Hunt et al., 2004), although clinical signs may persist (Hottinger et al., 1995). If the portal vasculature is sufficiently developed, ligation of the shunt with nonabsorbable suture is also possible (Burton and White, 2001; Lipscomb et al., 2007; Tivers and Lipscomb, 2011).

7. Prognostic factors

The prognosis for cats after surgical treatment has been reported to be moderate to poor, with long-term survival rates varying from 56 - 85%. In cats that survive the postoperative period and do not develop seizures, prognosis is good (Valiente et al., 2020). Death may occur in the intraoperative or early postoperative period and is caused by portal hypertension, complications of anaesthesia, portal vein thrombosis, seizures (Hottinger et al., 1995; Vogt et al., 1996; Hunt et al., 2004b), hypothermia, cardiorespiratory arrest (Hunt et al., 2004b), or euthanasia due to presumed portal vein atresia and inability to occlude the shunt (Lipscomb et al., 2007). Hunt et al. found (2004b) that after closure of shunts with cellophane band in cats, shunt closure may fail, or multiple acquired shunts may occur. If a shunt vessel is only partially closed clinical signs may still be present, although possibly to a lesser degree (Hottinger et al., 1995). A good indicator of shunt attenuation is bile acid stimulation, which correlates well with clinical outcome (Valiente et al., 2020).

8. Conclusion

Clinical signs in cats with PSS may be nonspecific and intermittent, so shunts are often not recognised early in the animal's life. Whenever a cat is presented with hypersalivation, copper-coloured irises, neurological signs, and prolonged recovery time after anaesthesia for elective surgery, PSS should be suspected. Prognosis after surgical occlusion is better compared with medical treatment alone but generally worse than in dogs. If the shunt remains patent after surgery, further occlusion may be attempted.

Conflicts of Interest: The authors declare no conflict of interest.



References

1. Bernard JM, Doursout MF, Wouters P et al. Effects of sevoflurane and isoflurane on hepatic circulation in the chronically instrumented dog. *Anesthesiology*. 1992; 77: 541–545. DOI: 10.1097/0000542-199209000-00021
2. Birchard SJ, Sherding RG. Feline portosystemic shunts. *Compend Contin Educ Pract Vet* 1992; 14: 1295–1301. DOI: 10.1016/j.jfms.2011.01.01
3. Broome CJ, Walsh VP, Braddock JA. Congenital portosystemic shunts in dogs and cats. *N Z Vet J*. 2004; 52: 154–162. DOI:10.1080/00480169.2004.10749424
4. Burton CA, White RN. Portovenogram findings in cases of elevated bile acid concentrations following correction of portosystemic shunts. *J Small Anim Pract*. 2001; 42: 536–540. DOI: 10.1111/j.1748-5827.2001.tb06023.x.
5. Center SA, Erb HN, Joseph SA. Measurement of serum bile acids concentrations for diagnosis of hepatobiliary disease in cats. *J Am Vet Med Assoc*. 1995; 207: 1048-1054.
6. Day SL. Anaesthesia and portosystemic shunt ligation in the feline patient. *Vet Nurs J*. 2013; 28: 364-368. DOI: 10.1111/vnj.12084
7. Davis H, Jensen T, Johnson A et al. AAHA/AAFP fluid therapy guidelines for dogs and cats. *J Amer Anim Hosp Assoc*. 2013; 49: 149–159. DOI: 10.5326/JAAHA-MS-5868
8. Heldmann E, Holt DE, Brockman DJ et al. Use of propofol to manage seizure activity after surgical treatment of portosystemic shunts. *J Small Anim Pract*. 1999; 40: 590-594. DOI: 10.1111/j.1748-5827.1999.tb03029.x.
9. Hottinger HA, Walshaw R, Hauptman JG. Long-term results of complete and partial ligation of congenital portosystemic shunts in dogs. *Vet Surg*. 1995; 24: 331–336. DOI: 10.1111/j.1532-950x.1995.tb01339.x.
10. Hunt GB. Effect of breed on anatomy of portosystemic shunts resulting from congenital diseases in dogs and cats: a review of 242 cases. *Aust Vet J*. 2004a; 82: 746-749. DOI: 10.1111/j.1751-0813.2004.tb13233.x.
11. Hunt GB, Kummeling A, Tisdall PLC, et al. Outcomes of Cellophane Banding for Congenital Portosystemic Shunts in 106 Dogs and 5 Cats. *Vet Surg*. 2004b; 33: 25–31. DOI: 10.1111/j.1532-950x.2004.04011.x
12. Kyles AE, Hardie EM, Mehl M, Gregory CR. Evaluation of ameroid ring constrictors for the management of single extrahepatic portosystemic shunts in cats: 23 cases (1996–2001). *J Am Vet Med Assoc*. 2002; 220: 1341–1347. DOI: 10.2460/javma.2002.220.1341
13. Lemke KA. Perioperative use of selective alpha-2 agonists and antagonists in small animals. *Can Vet J*. 2004; 45: 475–480. PMID: 15283516
14. Levy JK, Bunch SE, Komtebedde J. Feline portosystemic vascular shunts. In: Bonagura JD, editor. *Kirk's current veterinary therapy XII small animal practice*. Philadelphia, ZDA, WB Saunders. 1995; pp. 743–749.
15. Lidbury JA, Cook AK, Steiner JM. Hepatic encephalopathy in dogs and cats. *J Vet Emerg Crit Care*. 2016; 26: 471–487. DOI: 10.1111/vec.12473
16. Lipscomb VJ, Jones HJ, Brockman DJ. Complications and long-term outcomes of the ligation of congenital portosystemic shunts in 49 cats. *Vet Rec*. 2007; 160: 465-470. DOI: 10.1136/vr.160.14.465
17. Murrell JC, Hellebrekers LJ. Medetomidine and dexmedetomidine: a review of cardiovascular effects and antinociceptive properties in the dog. *Vet Anaesth Analg*. 2005; 32: 117–127. DOI: 10.1111/j.1467-2995.2005.00233.x
18. Murrell JC. Pre-anaesthetic medication and sedation. In: Duke-Novakovski T, de Vries M, Seymour C, editors. *BSAVA manual of canine and feline anaesthesia and analgesia*. 3rd ed. Gloucester, UK, British Small Animal Veterinary Association. 2016; pp. 170-189.
19. Ruland K, Fischer A, Hartmann K. Sensitivity and specificity of fasting ammonia and serum bile acids in the diagnosis of portosystemic shunts in dogs and cats. *Vet Clin Pathol*. 2010; 39: 57–64. DOI: 10.1111/j.1939-165X.2009.00178.x.
20. Self I. Gastrointestinal, laparoscopic and liver procedures. In: Duke-Novakovski T, deVries M, Seymour C, editors. *BSAVA Manual of canine and feline anaesthesia and analgesia*. Gloucester, UK. British Small Animal Veterinary Association; 2016; pp. 343-355. DOI: 10.22233/9781910443231.24
21. Tivers M, Lipscomb V. Congenital Portosystemic Shunts in Cats: Investigation, Diagnosis and Stabilisation. *JFMS*. 2011; 13: 173-184. DOI: 10.1016/j.jfms.2011.01.010
22. Tobias KM. Portosystemic shunts and other hepatic vascular anomalies. In: Slatter D, editor. *Textbook of small animal surgery*. 3rd ed. Philadelphia, ZDA, WB Saunders. 2003; pp. 727–751.
23. Tonge ME. Sedation and general anaesthesia of the portosystemic shunt patient. *Companion animal*. 2021; 26: 1-9. DOI: 10.12968/coan.2020.0103
24. Valiente P, Trehy M, White R et al. Complications and outcome of cats with congenital extrahepatic portosystemic shunts treated with thin film: Thirty-four cases (2008-2017). *J Vet Intern Med*. 2020; 34: 117-124. DOI: 10.1111/jvim.15649
25. Vogt JC, Krahwinkel DJ, Bright RM, et al: Gradual occlusion of extrahepatic portosystemic shunts in dogs and cats using the ameroid constrictor. *Vet Surg*. 1996; 25: 495–502. DOI: 10.1111/j.1532-950x.1996.tb01449.x.



-
26. Youmans KR, Hunt GB. Cellophane banding for the gradual attenuation of single extrahepatic portosystemic shunts in eleven dogs. *Aust Vet J.* 1998; 76: 531–537. DOI: 10.1111/j.1751-0813.1998.tb10208.x.
 27. Zwingenberger A. CT diagnosis of portosystemic shunts. *Vet Clin North Am Small Anim Pract.* 2009; 39: 783-792. DOI: 10.1016/j.cvsm.2009.04.008

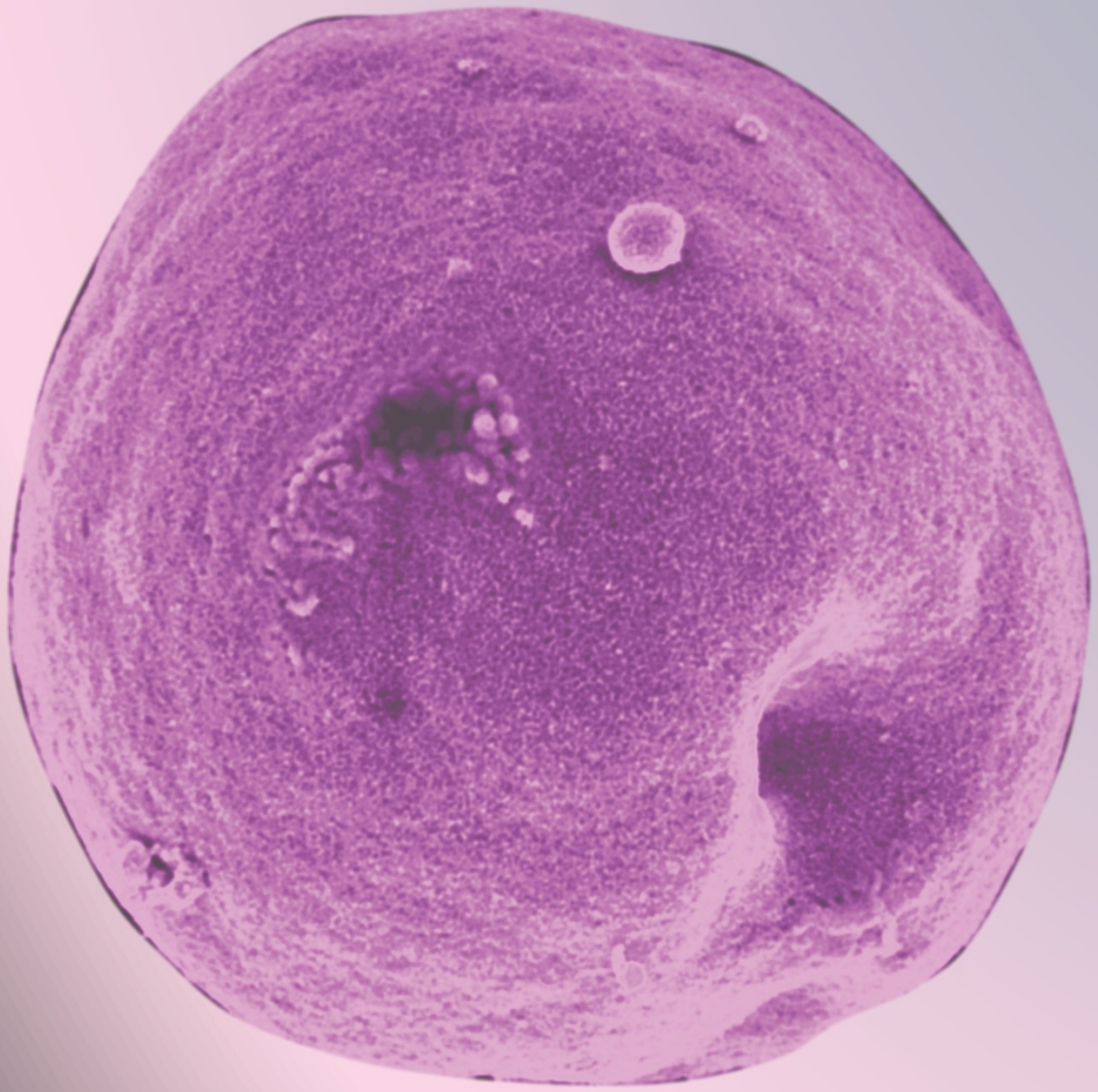



Invited lecture/Case report

Successful Second Intention Healing of a Large Skin Wound in a Cat's Cheek Using Manuka Honey

Kail Paul AC*

*Correspondence: Paul Kail: pkail@runbox.com

Citation: Kail Paul AC. Successful second intention healing of a large skin wound in a cat's cheek using Manuka honey. Proceedings of Socratic Lectures. 2023, 8; 41-44. <https://doi.org/10.55295/PSL.2023.II7>

Publisher's Note: UL ZF stays neutral with regard to jurisdictional claims in published maps and institutional affiliations.



Copyright: © 2023 by the authors. Submitted for possible open access publication under the terms and conditions of the Creative Commons Attribution (CC BY) license (<https://creativecommons.org/licenses/by/4.0/>).

Abstract:

A recent case report (Lukanc et al., 2020) demonstrated successful second-intention healing of a large skin wound on a cat's leg. The wound was treated with honey to kill pathogens, stimulate the immune response and keep the wound moist. The present case report complements this result by showing a similar result in a different part of the body. The subject presented with a burst abscess which left 42-45 square cm of necrotic skin on the side of his cheek. The wound healed over a period of two months through a combination of new skin regeneration and the stretching of existing skin. As a result of this, euthanasia was avoided and the patient made a full recovery. The case report details stages in the recovery process and discusses the challenges of protecting the wound while still allowing the patient to experience a reasonable quality of life.

Keywords: Skin healing; Second-intention; Manuka honey



1. Background

The patient was a 16-year old castrated male Exotic Shorthair Cat with no underlying health issues. He was treated as an in-patient in a local veterinary clinic for the first three days, then he was treated at home.

Following a bite wound from another cat received during play fighting, the patient developed an abscess on his cheek which grew rapidly over the course of two days. He scratched it, causing it to bleed. At this point, the veterinary clinic was contacted for an emergency appointment. By the time he had reached hospital, the skin had broken and the abscess had burst, releasing large amounts of pus. The patient was in a state of shock and was dehydrated, and was therefore put on a saline drip. A blood panel showed elevated white blood cell count but was otherwise normal.

2. Wound debridement

The wound was initially de-bridged under local anaesthetic to reveal a small hole in the middle (1cm x 1cm). The total area of apparently necrotic tissue was about 6.5 cm x 6.5 cm.

3. Antibiotic treatment

Each day for the next three days the patient was given Cefazolin (1.76 ml) together with Buprenorphine (0.08 mg) for pain relief. His wound was cleaned, flushed and debrided under local anaesthetic. Before being sent home he was injected with 0.4ml Convenia. On days 10-30 this was supplemented with Clavaseptin (62.5mg x 2/day).

4. Use of Manuka Honey

For days 1 and 2 the wound was treated with supermarket honey; this was changed to Viaderm (Taro Pharmaceuticals Inc., Brampton, Ont, CA) for days 3, 4, 5, and 6 and then replaced with Manuka honey for the rest of his treatment. There was a noticeable increase in redness after the honey was used (presumably because Viaderm contains triamcinolone, which reduces inflammation).

Several benefits to using Manuka honey were reported (see Lukanc et al., 2018), e.g. it has broad-spectrum antibacterial properties, provides a moist healing environment and stimulates angiogenesis and the formation of granulation and epithelial tissue.

Manuka honey is available at low cost, without a prescription. Its content is regulated by an independent body (umf.org.nz) and given a Unique Manuka Factor (UMF) score which measures its potency and its content of leptosperin, a natural anti-inflammatory agent. A separate classification system, the Methylglyoxal (MGO) score, is based on its methylglyoxal content in mg/kg, and a measure of its antibacterial potency. This case study used Flora brand, which has a 400+ MGO rating (showing 400mg/kg of methylglyoxal) and a 12+ UMF rating. The honey was applied to the non-adhesive dressing (see below) using a sterile cotton-tipped applicator (AMG Medical Inc., Montreal, QC, CA). Because of the extensive bandaging it largely stayed in place and stayed moist between dressing changes (**Figure 1D**).

5. Dressings

The wound was dressed with a non-adhesive pad (McKesson, Montreal, QC, Canada). The non-adhesive pad was protected with several layers of strong bandages held in place with electrical tape to form a semi-rigid helmet. In addition, the patient wore a collar to prevent scratching (**Figure 1A**). The wound was rinsed with sterile saline and the dressings were changed daily. After the first ten days the frequency was reduced to every three days and this was reduced still further, until the last month, when dressings were replaced every week. The position of the bandages were checked frequently to make sure they hadn't slipped (or been pulled off) and that there was no smell or exudate, which would have indicated an infection. The wound was also photographed regularly to monitor changes.

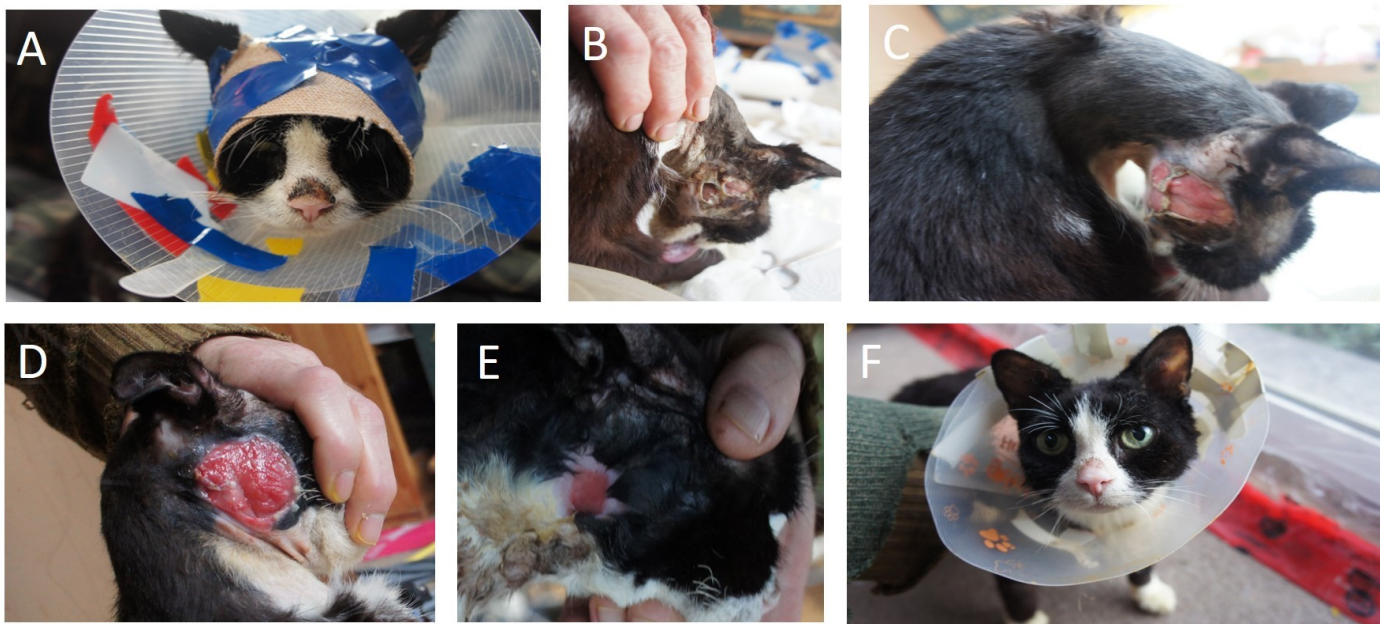

Figure 1. A: Bandaging and collar applied to the patient. B: The wound one week after the abscess burst. C: The wound two weeks after the abscess burst. D: After 24 days the granulation tissue was much smoother. E: Rapid contraction by day 42 to 1cm across. F: The patient after his wound had healed.

6. Welfare Aspects

The patient showed no sign of depression or significant behavioural changes and appeared to be in good spirits throughout his treatment. He kept up his normal activities but was more subdued than normal when interacting with other cats (probably because of physical limitations caused by his protective collar). He was only allowed outside for very brief periods in case he came into contact with raccoons. He was able to eat and drink with the collar in place but was spoon-fed to make this easier for him. He attempted to scratch at the cone and dressings, sometimes for several minutes at a time, and managed to remove them on two occasions. The replacement of dressings was stressful, so the frequency of this procedure was kept to a minimum (see above). Buprenorphine was discontinued after day 4 because this was causing constipation and urinary retention. The only time when the patient appeared to be in pain was when his granulation tissue was flushed with sterile saline. The main welfare issue was that he had to be heavily bandaged (**Figure 1**). There's no doubt that this was uncomfortable. However, it's not uncommon for humans who have a broken limb to wear a similarly uncomfortable plaster of Paris, often for many months. Even at 16, there was a reasonable expectation that he would have several more years of good quality life ahead of him, so the trade-off between short-term discomfort and long-term benefit seemed reasonable. The initial prognosis was of 20% survival; however, encouraging indications could be found in the literature (e.g. Lukanc et al., (2020)).

7. Healing process

Figure 1B shows the wound one week after the abscess burst. At this stage, there were two holes in the necrotic tissue, exposing what appeared to be granulation tissue underneath. **Figure 1C** shows the wound one week later. At this stage, more of the necrotic skin had sloughed off. There was some concern at this stage about the interface between the granulation layer and the existing healthy skin: it looked as though a pouch was forming. Over the following two weeks, the wound contracted extremely quickly. It was clear that this was from the stretching of the surrounding skin, because this skin already had fur on it. A small circle of new epithelial cells approximately 1 mm across could be seen around the wound. The underlying structures were not smooth, and there was some concern at



this stage that the new skin would not follow the contours of this tissue: for example, in **Figure 1C** there are obvious folds and pockets. However, the granulation tissue gradually became smoother (**Figure 1D**). After 24 days, the granulation tissue was much smoother. Between 24 days and 42 days the size of the wound decreased very rapidly down to about 1 cm in diameter (**Figure 1E**), again, due to stretching of the surrounding skin. The color of the wound became less red, suggesting the formation of a thin epithelial layer across the whole surface. Over the following 27 days, the wound contracted much more slowly. On day 67, the bandages were removed, but the collar was kept in place for a further 60 days to give the new skin time to strengthen (the position of the wound made it very vulnerable to scratches from the patient's back claws) (**Figure 1F**).

8. Discussion

After the initial assessment, the patient was given a prognosis of 20% survival, on the basis that his necrotic skin would not heal and would become inflected. A skin graft was considered; however, because of the position of the wound (near to his jaw) there were concerns that it would not be possible to immobilize this long enough for a capillary bed to form. He lived in a very remote area in the North of Canada with extremely limited veterinary facilities.

However, a record of Lukanc et al., (2020), which described a similarly-sized wound, showed that complete wound healing by second intent was entirely possible.

The main challenge to a wound in this area was getting the dressings to stay in place. The patient managed to get them off twice by pushing against things, and they sometimes slipped back over his head, exposing part of the wound. Each time the dressings were changed he was closely monitored to check for problems.

There were two noticeable differences between this case and the case described in Lukanc et al., (2020). First, in the here presented case, the wound was smaller (42 – 45 cm² vs 51.54 cm²). Probably as a result of this, the wound healed more quickly (69 vs 105 days). This wound was on the cheek rather than the leg. Cheek skin is much looser, so there was much more capacity for existing skin to stretch. A second difference is that the three-dimensional structure of this wound was less straightforward. After two weeks a pouch formed, and there was concern that the new skin would not be continuous with the existing healthy skin. However, this problem resolved itself over the course of the following two weeks (**Figures 1D and E**).

This case shows that it's entirely possible to treat skin wounds of this magnitude in a domestic environment and in such a way that the patient can continue an almost normal life through the long healing process. Doctors of veterinary medicine need to be more aware that healing is possible, and that euthanasia can be avoided.

Conflicts of Interest: The author declares no conflict of interest.

References

1. Lukanc B, Potokar T, Erjavec V. Observational study of the effect of L-Mesitran® medical honey on wound healing in cats. *Vet Arh.* 2018; 88: 59-74. DOI:10.24099/vet.arhiv.160905a
2. Lukanc B, Potokar T, Erjavec V. Complete skin regeneration with medical honey after skin loss on the entire circumference of a leg in a cat. *J Tissue Viability.* 2020; 29: 148-152. DOI:10.1016/j.jtv.2020.03.007u

w: 2, c: 0.25, d: 1, k: -20, m: 2 | w: 2, c: 0.25, d: 1, k: -10, m: 2 | w: 2, c: 0.25, d: 1, k: -5, m: 2

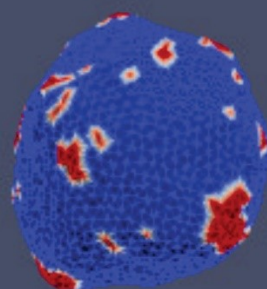
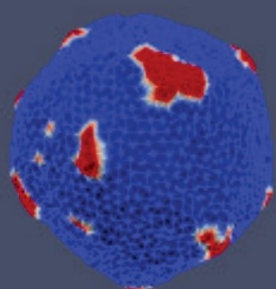
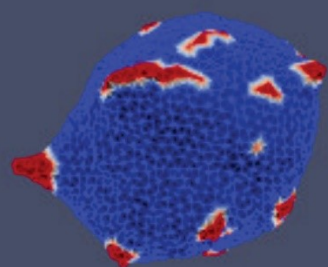

w: 2, c: 0.25, d: 1, k: 0, m: 2 | w: 2, c: 0.25, d: 1, k: 5, m: 2 | w: 2, c: 0.25, d: 1, k: 20, m: 2

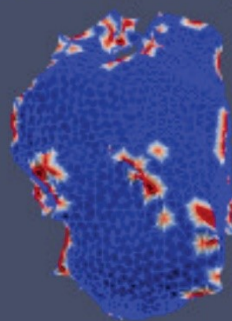
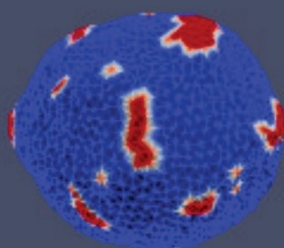
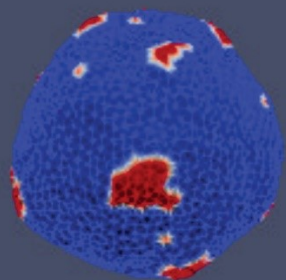

w: 2, c: 0.25, d: 1, k: 20, m: 2

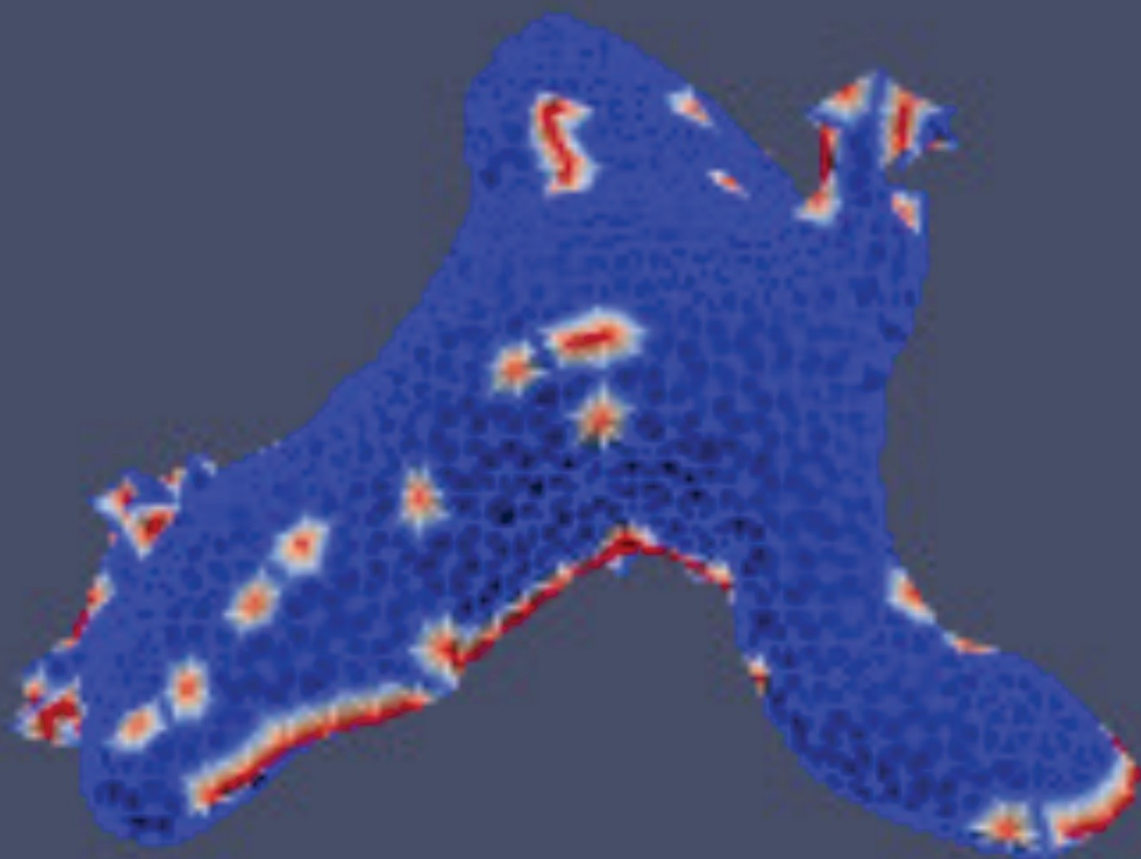



Invited lecture/Scientific contribution

Canine Dirofilariasis in the South Caucasus and its Pathomorphology

Tsitskishvili Levan¹, Makaradze Levan², Kurashvili Tengiz², Milashvili Nino^{2,3},
Makaradze Zurab², Sanaia Ekaterina^{4,*}

1. Scientific-Research Center of Agriculture (SRCA), Tbilisi, Georgia
 2. Samtskhe-Javakheti State University of Georgia (SJSU), Akhaltsikhe, Georgia
 3. European University (EU), Tbilisi, Georgia
 4. Georgian Technical University (GTU), Tbilisi, Georgia
- * Correspondence: Ekaterine Sanaia; esanaia@gmail.com

Abstract:

The main goal of this paper is to provide the results of a study on the regional distribution of dirofilariasis (causative agent: *Dirofilaria immitis*, *Dirofilaria repens*, and other concurrent filarial species in animal reservoirs) among the canine population in Georgia and Armenia and estimate the disease burden in these countries.

In total, 1065 animals were investigated in the different regions of Armenia and Georgia, and 26 positive cases were detected. The prevalence of dirofilariasis is 2.4%. However, it varies across regions from 0% to 25%. The Kruskal-Wallis test showed that variation is statistically significant ($P=0.01$). The majority of positive cases (11) were from the Kvemo Kartli region (Georgia). The highest number (7) of cases have been found in the Armavir region (Armenia). The other cases were found in Tbilisi / Capital City of Georgia (two cases), Yerevan / Capital City of Armenia (two cases), Shirak Region (two cases), and only one case in regions Achara and Ararat.

Citation: Tsitskishvili L, Makaradze L, Kurashvili T, Milashvili N, Makaradze Z, Sanaia E. Canine Dirofilariasis in the South Caucasus and its Patho-morphology. Proceedings of Socratic Lectures. 2023, 8; 46-51.
<https://doi.org/10.55295/PSL.2023.II8>

Publisher's Note: UL ZF stays neutral with regard to jurisdictional claims in published maps and institutional affiliations.



Copyright: © 2023 by the authors. Submitted for possible open access publication under the terms and conditions of the Creative Commons Attribution (CC BY) license (<https://creativecommons.org/licenses/by/4.0/>).

Keywords: *Dirofilaria* spp., Canine Dirofilariasis, Georgia, Armenia, South Caucasus, Vector-Borne disease (VBD)



defined based on animal age, gender, brief preliminary health assessment, and geographic origin). On-site examination lab sampling and data collection procedures of the 10% study population were implemented. For each animal examined by the veterinarian, the following information relevant to the epidemiological investigation was recorded on a data sheet: 1) Individual animal identity; 2) Age; 3) Gender; 4) Breed; 5) Lifestyle; 6) Husbandry.

2.2. Methods of Laboratory Research

Blood was collected from the cephalic vein (5 ml) and stored in tubes with anticoagulant (e.g., EDT; 2.5 ml) or in a serum-separating tube (2.5 ml) and later processed for molecular analyses and for parasitological and serological analysis.

Parasitological and Serological Testing. The modified Knott's technique (KN) and direct smear methods were used for microscopic detection and identification of microfilariae in blood smears. The commercial kit WITNESS®*Dirofilaria* (WT) (Synbiotics, San Diego, CA, USA) & SNAP 4Dx Plus (IDEXX Laboratories, Inc.) was employed for the detection of *D. immitis* circulating antigen in serum.

Molecular Testing. The aim of molecular studies was to identify *Dirofilaria species* circulating in Georgia and Armenia and to perform sequence analysis of detected species.

A variety of PCR-based methodologies were applied. (Watts et al., 1999; Mar et al., 2002; Rishniw et al., 2006; Latrofa et al., 2012) to diagnose zoonotic filariae in dogs and a combination of PCR and restriction fragment length polymorphism (RFLP) analysis (Nuchprayoon et al., 2003; Nuchprayoon et al., 2005) are employed to differentiate a wide spectrum of the filarial species. In this project, we used a species-specific semi-nested PCR assay, which was based on the amplification of internal transcribed spacer regions ITS1/ITS2 and enables the simultaneous detection and differentiation of filarial species in clinical specimens (Ferreira et al., 2017). Particularly, in a first-round, PCR the entire ITS region was expanded; in second-round PCR, the amplification of ITS1 and ITS2 regions allowed to identify *D. immitis*, *D. repens*, as well as other filariids - *A. reconditum* and *A. dracunculoides* depending on the size of amplification products.

The PCR products were purified and sequenced using BigDye® Terminator v3.1 Cycle Sequencing Kit (Applied Biosystems Inc.) in an automated sequencer (ABI-PRISM 377; Applied Biosystems Inc.). All sequences generated has compared to sequences available in GenBank using the Basic Local Alignment Search Tool (BLASTn). Based on the sequencing results, a phylogenetic investigation between species detected in Georgia and Armenia and those reported worldwide has also carried out.

2.3. Data analysis.

Canine dirofilariasis prevalence for each region of Georgia and Armenia was estimated by calculating descriptive statistics and their 95% CI. Logistic regression analysis at 95 % confidence was performed, and the odds ratios (OR) were calculated in order to estimate the epidemiological measure of the association between the variables included in the study (age, gender, breed, lifestyle, husbandry) and the prevalence of canine dirofilariasis. Then this analysis was repeated for each distinct form of canine dirofilariasis separately. The goodness-of-fit for all statistical models has assessed by C-statistics and Kruskal-Wallis one-way ANOVA test. All statistical analysis is done in SAS 9.2.

GIS is used to map the spatial distribution of canine dirofilariasis in the territory of Georgia and Armenia. Maps were created using regions as geographical units in order to display the latter with the number of animals examined and the prevalence (%) of disease for each region of Georgia and Armenia.

3. Results

The cross-sectional study design was employed to collect animal information and blood samples from the canine population. The project has carried out in veterinary clinics and animal shelters in the different regions of Georgia and Armenia. In total, 1065 animals were investigated and there were 26 positive cases. The prevalence of dirofilariasis is 2.4%. (**Figure 1 left, Table 1**). However, it varies across regions from 0% to 25%. The Kruskal-Wallis test showed that variation is statistically significant ($P=0.01$). The majority of positive cases

(11) were from the Kvemo Kartli region (Georgia). The following highest number (7) of cases were found in the Armavir region (Armenia). The other cases were found in Tbilisi / Capital City of Georgia (two cases), Yerevan / Capital City of Armenia (two cases), Shirak Region (two cases), and only one case in regions Achara and Ararat.

By using GIS and Google Earth Pro systems, it was possible to study in detail the areas where cases of dirofilariasis had been detected. (**Figure 1**, right)

Table 1. Regional distribution of all investigated animals and positive cases

Regions (Georgia & Armenia)	# of Investigated animals	HW Positive	HW Total %
Achara+Guria	57	1	1.8
Imereti+Racha	61	0	0.0
Kakheti	49	0	0.0
Kvemo Kartli	62	11	17.7
Mtskheta-Tianeti	46	0	0.0
Javakheti	43	0	0.0
Samegrelo	52	0	0.0
Shida kartli	47	0	0.0
Tbilisi	155	2	1.3
Shirak	23	2	8.7
Armavir	28	7	25.0
Ararat	27	1	3.7
Syuniq	12	0	0.0
Yerevan	403	2	0.5
Total	1065	26	2.4

The result is significant at $p < 0.01$ (By Kruskal-Wallis)

Pathomorphology of dirofilariasis

The post-mortem examination of the fallen dogs with dirofilariosis was carried out in the veterinary clinic by the method of complete evisceration (**Figure 2A**). **Figures 2B-F** show representative outcome of an autopsy. The studies were carried out by both macroscopic and microscopic methods. During the study, it is important to note changes that have developed inside and outside the heart. Macromorphological studies have shown that dirofilaries are localized in both the right and left atria of the heart, but in terms of the severity of the location of parasites in the right atrium, their number is significantly higher in the right than in the left half (**Figure 2B**). Studies have also found that with intensive invasion, a certain amount of dirofilariae are localized in the lumen of the vena cava, at the junction with the atrium (**Figure 2C**). Diffuse enlargement of the heart occurs in the cardiac form of dirofilariosis. Microscopically, the enlargement of the heart is myogenic in nature, the muscle fibers are stretched in a transverse direction. The systolic state of the heart is sharply weakened due to myogenic heart failure, which is also confirmed by the mass of clotted blood in the cavities of the heart (**Figure 2D**). The coronary vessels were dilated and filled with blood. Due to a sharp violation of heart function as a complication in various organs, significant pathomorphological changes developed, in most cases incompatible with fever, namely: visible mucous membranes were cyanotic, venous congestion and edema were observed in the lungs, which was accompanied by hypostatic pneumonia, and with chronic course - compaction of the lungs. In the liver, as in other internal organs, cyanosis and dystrophic processes were noted, which could be accompanied by the development of micronecrotic foci and the development of connective tissue (in conditions of a prolonged form of the disease) with subsequent cirrhotic change. The gallbladder was filled, the walls were thickened. Kidneys were involved in the process, where changes characteristic of glomerular nephritis were observed in both acute (at the beginning) and chronic (protracted) form. The bladder was paralyzed and filled with urine, which further complicated the course and outcome of the disease (**Figure 2E**), especially in the cases subjected to complications with uremia. The spleen was enlarged in volume.

In the empty intestine, (especially in the small intestine), a pattern of flatulence was observed (**Figure 2F**). In the acute form, with intensive invasion of the disease, effusion was always recorded in the abdominal cavity and in the pericardium.

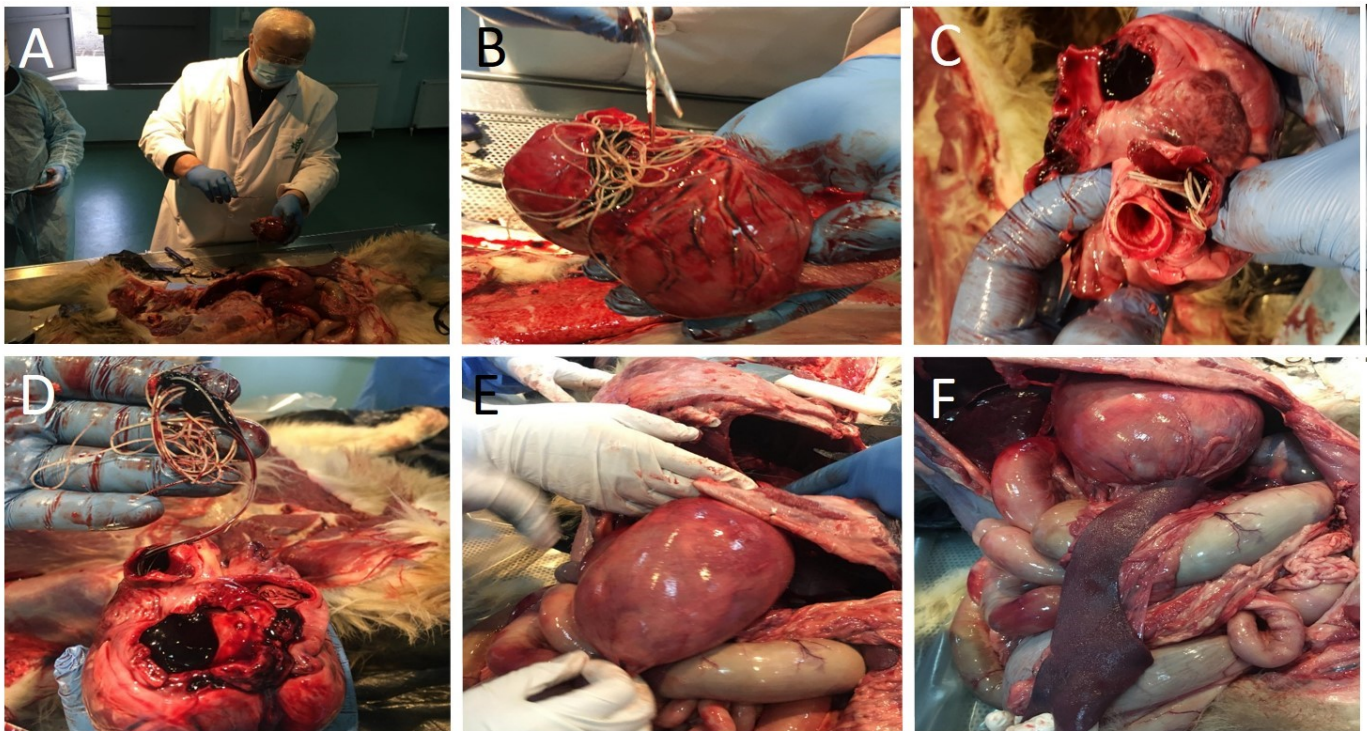

Figure 2. A: Autopsy of a fallen dog with dirofilariosis. B: Dirofilariae in the right atrium. C: Dirofilariae in the vena cava. D: Mass of clotted blood in the heart cavity. E: Paralysis of the bladder, urine overflowing. F: Spleen hyperplasia and flatulence.

4. Discussion

It should be underlined that 11 of the positive cases in Georgia were detected in the Kvemo Kartli region (Gardabani municipality), 2 cases in Tbilisi (Metropolitan city of Georgia), and 1 case in Achara. In Armenia, infected animals were detected in the regions bordering Turkey (Shirak, Armavir, Ararat). The study showed that the South Caucasus region is unreliable concerning the distribution of zoonotic vector-borne pathogens (VBPs) and there is a necessity for further research, in both Georgia and Armenia as well as in the South Caucasus region as a whole. Based on the results of the project, we could identify vector-borne diseases in high-risk regions in Georgia and Armenia. No doubt, it is necessary to continue the study and this study should focus on the environmental factors that contribute to the existence of vectors.

Considering the zoonotic nature of VBPs, it undoubtedly poses a risk for the population of the South Caucasus. For further research, we consider it necessary to perform a phylogenetic analysis of VBPs circulating in the South Caucasus, which allows us to analyse the genetic relationship between the strains isolated in Georgia and Armenia and the strains isolated in other countries and assess the public risk burden of this disease for the South Caucasus region.

In many countries including the Post-Soviet, VBDs are not a nationally notifiable condition and according to local laws, reporting cases to the local health department is not obligatory. Accordingly reliable epidemiological data are not available.

Funding: The study was supported by International Science and Technology Center (ISTC), Project G-2414.

Conflicts of Interest: The authors declare no conflict of interest.



References

1. Ferreira C, Afonso A, Calado M, et al. Molecular characterization of *Dirofilaria* spp. circulating in Portugal. *Parasit Vectors*. 2017; 10: 250. DOI: 10.1186/s13071-017-2180-y
2. Latrofa MS, Weigl S, Dantas-Torres F, et al. A multiplex PCR for the simultaneous detection of species of filarioids infesting dogs. *Acta Trop*. 2012; 122:150-154. DOI: 10.1016/j.actatropica.2012.01.006
3. Mar PH, Yang IC, Chang GN, Fei AC. Specific polymerase chain reaction for differential diagnosis of *Dirofilaria immitis* and *Dipetalonema reconditum* using primers derived from internal transcribed spacer region 2 (ITS2). *Vet Parasitol*. 2002; 106: 243-252. DOI: 10.1016/s0304-4017(02)00032-8
4. Nuchprayoon S, Sangprakarn S, Junpee A, et al. Differentiation of *Brugia malayi* and *Brugia pahangi* by PCR-RFLP of ITS1 and ITS2. *Southeast Asian J Trop Med Public Health*. 2003; 2: 67-73.
5. Nuchprayoon S, Junpee A, Poovorawan Y, et al. Detection and differentiation of filarial parasites by universal primers and polymerase chain reaction-restriction fragment length polymorphism analysis. *Am J Trop Med Hyg*. 2005; 73: 895-900.
6. Rishniw M, Barr SC, Simpson KW, et al. Discrimination between six species of canine microfilariae by a single polymerase chain reaction. *Vet Parasitol*. 2006; 135: 303-314. DOI: 10.1016/j.vetpar.2005.10.013
7. Watts KJ, Courteny CH, Reddy GR. Development of a PCR- and probe-based test for the sensitive and specific detection of the dog heartworm, *Dirofilaria immitis*, in its mosquito intermediate host. *Mol Cell Probes*. 1999; 13: 425-30. DOI: 10.1006/mcpr.1999.0270

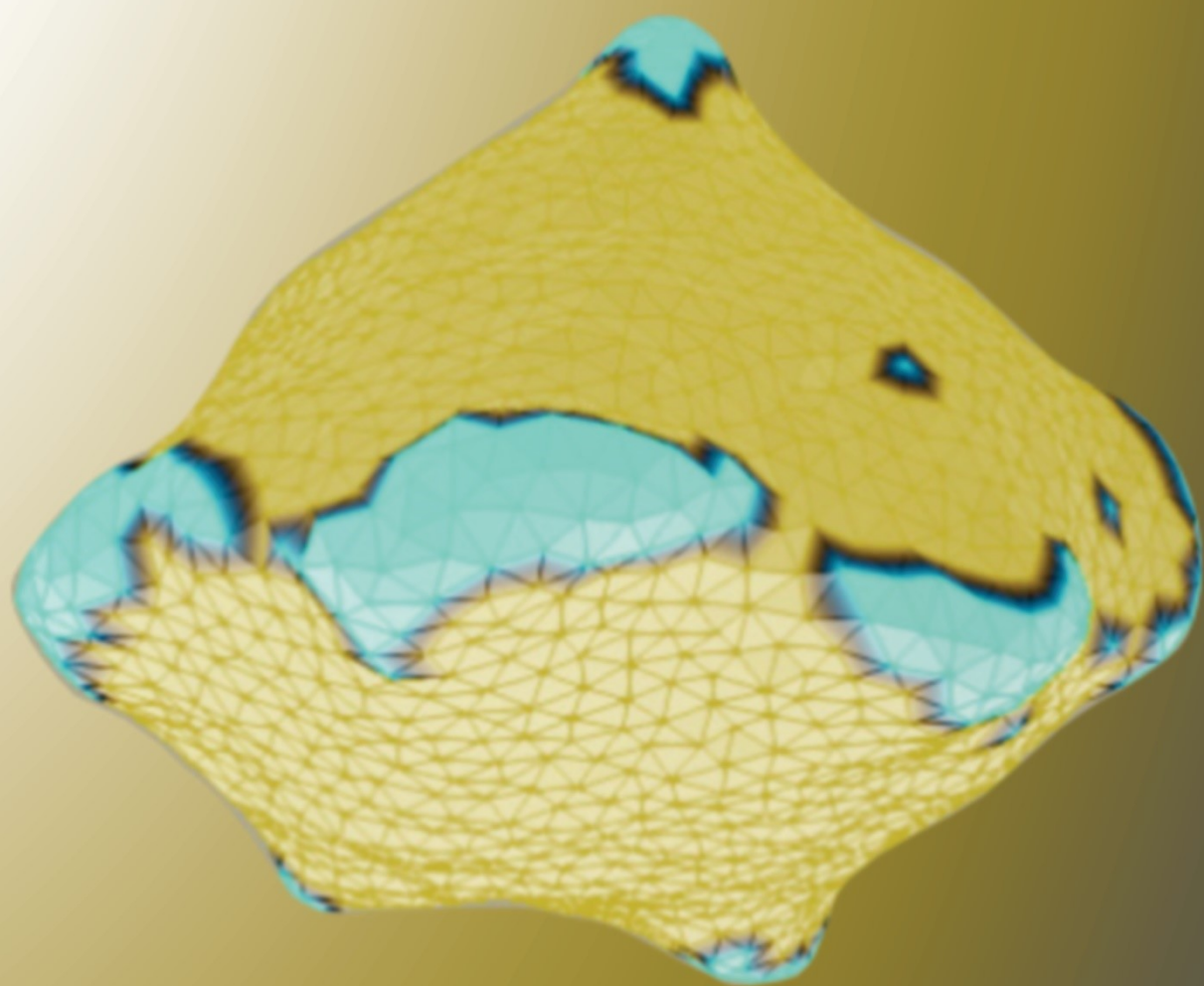



Invited lecture/Scientific contribution

Erythrocyte Sedimentation in Tubes for Preparation of Human, Equine and Canine Plasma Rich with Platelets and Extracellular Vesicles

Arko Matevž¹, Schlosser Gitta², Igljč Aleš^{3,4}, Kruljc Peter⁵, Nemeč Svete Alenka⁶, Erjavec Vladimira⁶, Kralj-Igljč Veronika^{1,*}

- ¹ University of Ljubljana, Faculty of Health Sciences, Laboratory of Clinical Biophysics, Ljubljana, Slovenia
- ² Eötvös Loránd University, Institute of Chemistry, Department of Analytical Chemistry, Budapest, Hungary
- ³ University of Ljubljana, Faculty of Electrical Engineering, Laboratory of Physics, Ljubljana, Slovenia;
- ⁴ University of Ljubljana, Faculty of Medicine, Laboratory of Clinical Biophysics, Ljubljana, Slovenia;
- ⁵ University of Ljubljana, Veterinary Faculty, Clinic for Reproduction and Large Animals, Ljubljana, Slovenia
- ⁶ University of Ljubljana, Veterinary Faculty, Small Animal Clinic, Ljubljana, Slovenia

* Correspondence: Veronika Kralj-Igljč veronika.kralj-iglic@zf.uni-lj.si

Abstract:

Sedimentation of erythrocytes in equine, human and canine blood was observed in tubes, intended for preparation of plasma rich with platelets and extracellular vesicles. We observed that in human blood, plasma formation started first, followed by equine blood and canine blood. All three dependencies of the length of the plasma column on time had sigmoid shape, however, the increment was greatest in equine blood. We observed higher propensity of equine blood to form erythrocyte rouleaux by light microscopy. Approximately 70-90% of haematocrit was reached by natural sedimentation of blood in all three species.

Keywords: Erythrocyte Sedimentation, Canine plasma, Human blood, Equine blood, Canine blood, Plasma Rich with Platelets and Extracellular Vesicles

Citation: Arko M, Schlosser G, Igljč A, Nemeč Svete A, Erjavec V, Kralj-Igljč V. Erythrocyte Sedimentation in Tubes for Preparation of Human, Equine and Canine Plasma Rich with Platelets and Extracellular Vesicles. Proceedings of Socratic Lectures. 2023, 8; 53-57.
<https://doi.org/10.55295/PSL.2023.II9>

Publisher's Note: UL ZF stays neutral with regard to jurisdictional claims in published maps and institutional affiliations.



Copyright: © 2023 by the authors. Submitted for possible open access publication under the terms and conditions of the Creative Commons Attribution (CC BY) license (<https://creativecommons.org/licenses/by/4.0/>).



1. Introduction

Platelet rich plasma is currently being used for treatment of variety of conditions in human and animals (Troha et al., 2023). As plasma contains also extracellular vesicles, it has been referred to as plasma rich with platelets and extracellular vesicles (PVRP) (Vozel et al., 2021). PVRP is being used in human medicine in different fields e. g. in treatment of ligament and tendon injuries, chronic wounds and burns (Troha et al., 2023). Regenerative effects of PVRP can be used in maxillofacial surgery, dental medicine, bone and joint disorders, ocular surface disorders, scar revision, alopecia and otorhinolaryngology. In veterinary medicine, PVRP is being used in therapy of ligament and tendon injuries, osteoarthritis, wound healing and treatment of burns (Troha et al., 2023). In the work of Carluccio et al. (2020), intrauterine PVRP injection proved to be beneficial in barren mares with chronic degenerative endometritis (Carluccio et al., 2020).

The contents of plasma depend on the processing methods and it is of key importance to understand these processes. There is no golden standard for preparation of plasma for all purposes and for all patients and it is indicated that optimal plasma preparation should be individualized (Steiner et al., 2022). Following analysis of patients with postoperative wounds in otorhinolaryngology (Vozel et al., 2021), a mathematical model was constructed to describe enrichment of plasma with platelets and extracellular vesicles (Božič et al., 2022). In the model, the development of plasma during sedimentation of erythrocytes (the length of the column of plasma in the tube) in dependence on time was estimated based on the data on erythrocyte sedimentation rate (ESR) as measured in the clinical laboratory (Božič et al., 2022). However, during preparation of therapeutic plasma, erythrocytes sediment in tubes of different shape than those used in measuring ESR in the clinical laboratories and it is of importance to predict the sedimentation rate in the tubes where preparation of PVRP will be made. Estimation of the processes taking place in blood would enable determination of optimal time needed to sediment erythrocytes and at the same time retain as many platelets and extracellular vesicles in plasma as possible. It is therefore of interest to find a possibility of the estimation of the optimal setting of the centrifuge and time on the basis of measurement of sedimentation of erythrocytes in the tubes for preparation of PVRP in gravitational field.

It is suggested that erythrocyte sedimentation varies widely among different animal species: in canine blood, it was much faster than in ruminant blood while in canine and porcine blood, it was in between (Ohi, 1964).

Since erythrocyte sedimentation in human and different animal species might play an important role in the preparation of individualized autologous PVRP, in this work we measured sedimentation of erythrocytes in gravitational field in three blood species: human, equine and canine. In this way we studied the same processes over a wider range of parameters, to get insight into the mechanisms taking place during the sedimentation of erythrocytes.

2. Methods

2.1 Blood sampling

The study was conducted according to the guidelines of the Declaration of Helsinki, according to the applicable Slovenian governmental regulations, Animal Protection Act, The Official Gazette of the Republic of Slovenia, no. 43/2007 and no. 38/13; human blood was donated voluntarily by the author of the study.

In human, collection was established in the morning after fasting for a minimum of 12 h overnight. A G21 needle (Microlance, Becton Dickinson, USA) and 2.7 mL evacuated tube with trisodium citrate (BD Vacutainers, 367714A, Becton Dickinson, USA) were used. Equine blood was taken from a 10 years old pregnant mare of Posavec breed owned by an author. Blood was collected twice, the first time the animal was healthy and two months later, when it developed an inflammation of the hoof (thrush on the right hind foot with grade 4 lameness). Equine blood was withdrawn by a G21 needle (Microlance, Becton Dickinson, USA) into evacuated 3 ml 454334 VACUETTE® Blood Collection Tubes (Greiner Bio-One International GmbH, Kremsmünster, Austria) with trisodium citrate by a veterinarian. Canine blood was obtained from a 22 months old female dog with no record of disease into 450 ml blood collection bag (PS11150, CompoFlex® Single, CPDA-1, Fresenius Kabi AG, 61346 Bad Homburg, Germany) for transfusion. However, blood was not used for transfusion up to the expired time and would be discarded. Four aliquots (volume 3 mL) of blood

were squeezed through a plastic tube into empty test tubes previously wetted by phosphate- and citrate-buffered saline.

2.2 Determination of haematocrit

After sedimentation of erythrocytes in human and in equine blood, plasma was collected and the remaining sediment was gently mixed by turning it upside down. Haematocrit was determined by centrifugation of the sample at $2000 \times g$ for 10 minutes in the Centric 400R centrifuge (Domel, Železniki, Slovenia), in the same tubes. It was assumed that at this setting all the plasma was pushed up above the erythrocytes. The length of the erythrocyte column was measured by a ruler and the proportion of the length of the erythrocyte column with respect to the length of the column of the whole blood was taken as the haematocrit.

2.3 Measurement of sedimentation of erythrocytes in gravitational field

Tubes with blood were put in the vertical position at room temperature, erythrocytes were allowed to sediment and plasma to form. The descent of the level of erythrocytes (the length of the plasma column) was measured with a ruler. Time in seconds was measured by a stopwatch. In human blood, one tube of blood was measured, in equine blood, two samples of blood from the same animal were observed one month apart and in canine blood, four tubes from a single animal were observed simultaneously.

2.4 Imaging of erythrocytes

Images of human, equine and canine erythrocytes were obtained by a light microscope Nikon Eclipse TE2000S inverted phase contrast microscope (Nikon Instruments Inc., Tokyo, Japan) with CCD 512 Digital Camera System SPOT BOOST (Visitron Systems, Puchheim, Germany).

3. Results

In human blood, plasma formation started first, followed by equine and canine blood (Figure 1). All three dependencies of the length of the plasma column on time indicated sigmoid shape, however, the increment was greatest in equine blood, as it has highest propensity to form erythrocyte rouleaux.

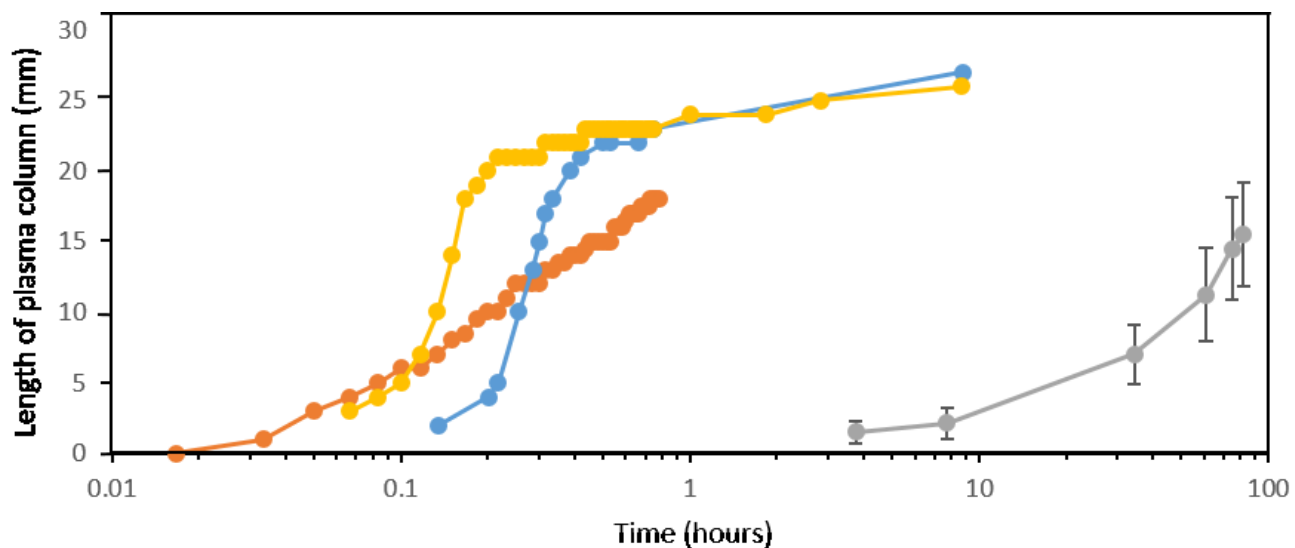

Figure 1. Erythrocyte sedimentation curve of equine (blue and yellow markings), human (orange markings) and canine (grey markings) blood. In the canine blood, the dots represent the average of 4 measurements. Bars represent standard deviations.

Human blood had higher haematocrit than animal blood (Table 1). When percentage of haematocrit was calculated, there were large differences in the percent of haematocrit that was reached by natural sedimentation in gravitational field.

Table 1. Comparison of haematocrit reached in human, equine and canine blood

Species of blood	Hematocrit	Percent of hematocrit reached by spontaneous sedimentation
Human	0.45	63
Equine	0.34	96
Canine	0.25	52

Figure 2 shows light microscope images of erythrocytes of all three species. Discocyte shape of erythrocytes prevailed in human blood (Figure 2A). In equine blood, erythrocytes organized in a rouleau (Figure 2B, white arrow). In canine blood, echinocytes (Figure 2C, white arrow) and ghosts (transparent cells, Figure 2C) were observed.

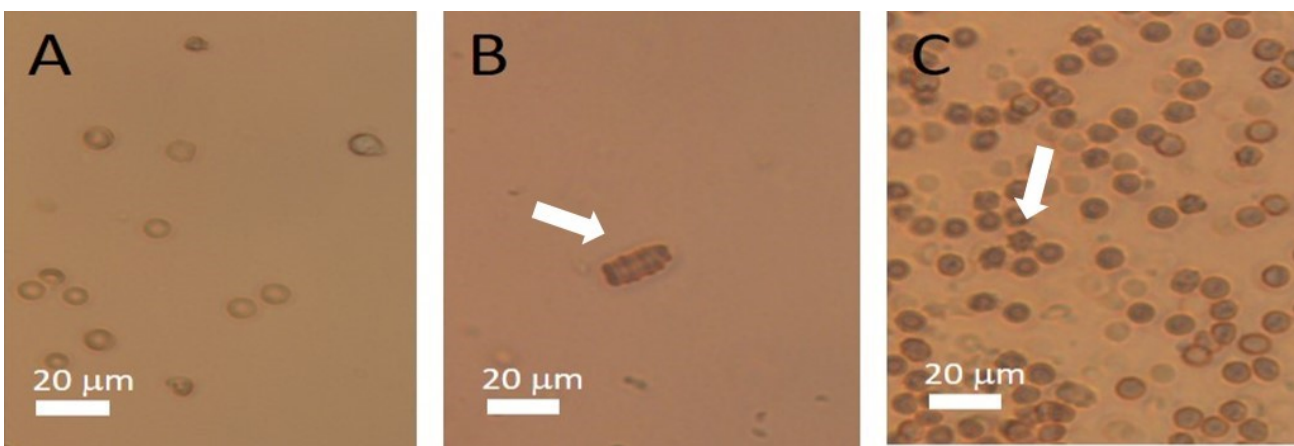

Figure 2. Light microscope image of human (A), equine (B) and canine (C) erythrocytes. On image B, there is a rouleau of stacked up equine erythrocytes (white arrow). On image C there are some echinocytes (white arrow).

4. Discussion

We have measured the velocity of sedimentation of erythrocytes in three types of blood: human, equine and canine. In human blood we stopped the measurement when we observed no more changes for more than one hour, while in canine blood this time was more than 6 hours. However, the length of the erythrocyte column reached the estimated hematocrit value only to a certain extent. To estimate the hematocrit, we sedimented erythrocytes in the centrifuge by choosing the settings so that all the plasma was pushed above the erythrocytes.

We have observed that the shape of the velocity/time curve was sigmoidal in all three species, with different increments. In equine blood, the increment was the greatest and the curve reached the plateau. In contrast, in human and in canine blood, the sedimentation stopped before the plateau was reached, yet the sediment still contained plasma which could be squeezed out by centrifugation. As during sedimentation of erythrocytes plasma is pushed up, the process is slowed down when erythrocytes are settled. It seems that movement and organization of erythrocytes during sedimentation is key in development of the flow of particles. As erythrocytes are denser and larger than other particles, they are pushed down by the systemic centrifugal force. In order to enable movement of erythrocytes, plasma makes space by moving in the opposite direction. This is made more effective by redistribution of erythrocytes to form channels. As the centrifugal force is proportional to the distance between the axis of the centrifuge rotor and the position of the particle in the tube, it is the greatest at the bottom of the tube and the flow of plasma upwards is the greatest at the early phases of the sedimentation. While the erythrocytes settle at the bottom and closely pack,



they cease to generate the plasma flow. Also, it could be expected that a large mass of erythrocytes (higher hematocrit) would create more obstacles for the movement of plasma upwards and decrease the increment of the sigmoid curve.

Sedimentation of erythrocytes in different animal species was a subject of interest already in the past. In a thorough work of Ohi (1964) presents a series of experiments on different species (horses, pigs, dogs, cattle and goats) to obtain the respective sedimentation curves. In that work, the sedimentation curves were grouped in five types: vertical, steep sloped, gentle sloped, sloped straight line and horizontal straight line. In equine blood, vertical curve type prevailed, in porcine blood there were steep sloped, gentle sloped and straight line types, in canine blood, the shapes were of steep sloped, gentle sloped, straight line and horizontal straight line types. In ruminants like cattle, sheep and goats, horizontal straight line type prevailed. According to Ohi, human and equine erythrocyte sedimentation curve obtained in this work could be considered vertical while canine sedimentation curve can be considered straight line type.

In the work of Fabry (1987), sigmoid or S-shaped erythrocyte sedimentation curve by exposing a shift to the right is explained in terms of increasing erythrocyte concentration; for higher hematocrit, the delay of the initial phase increases and the slope in the following phase decreases; at higher hematocrit, the shape of the curve is similar to sloped straight line and horizontal straight line of the classification of Ohi, 1964. In our samples, the increment of the curve in human which had highest hematocrit, was smaller which agrees with the above. However, this blood started to sediment first (Figure 1).

In a horse, we made two measurements. In the first measurement the horse was healthy while in the second, 2 months later, it developed a local infection. We observed that the curve of blood subjected to the infection was shifted to the left (shorter time) but retained the increment.

Human and equine blood were fresh while canine blood was from an expired transfusion bag, taken a month before the measurement took place. Sedimentation of erythrocytes in this blood was considerably slower and it took more than two days to approach its final value. It should also be taken into account that the samples were not handled equally which could have an important impact on the results. Human blood was transported from the clinical laboratory to the facility where the observation took place while equine blood was measured at the place of blood acquisition.

Funding: Authors acknowledge support from ARRS, grants P2-0232, P3-0388, J2-4447, J3-3066 and National Research, Development and Innovation Office (Hungary) SNN 138407.

Conflicts of Interest: The authors declare no conflict of interest.

References

1. Božič D, Vozel D, Hočevar M, et al. Enrichment of plasma in platelets and extracellular vesicles by the counterflow to erythrocyte settling. *Platelets*. 2022; 33: 592-602. DOI: 10.1080/09537104.2021.1961716.
2. Carluccio A, Veronesi MC, Plenteda D, Mazzatenta A. Platelet-rich plasma uterine infusion and pregnancy rate in barren mares with chronic degenerative endometritis. *Pol J Vet Sci*. 2020; 23: 431-438. DOI: 10.24425/pjvs.2020.134688.
3. Fabry TL. Mechanism of erythrocyte aggregation and sedimentation. *Blood*. 1987; 70: 1572-1576.
4. Ohi S. Studies on species variation of blood sedimentation in domestic animals. Variation of erythrocyte sedimentation curve. *Nihon Chikusan Gakkaiho* 1964; 35: 131-134.
5. Steiner N, Vozel D, Urbančič J, et al. Clinical Implementation of Platelet- and extracellular vesicle-rich product preparation protocols. *Tissue Eng Part A*. 2022; 28:770-780. DOI: 10.1089/ten.TEA.2022.0024.
6. Troha K, Vozel D, Arko M, et al. Autologous platelet and extracellular vesicle-rich plasma as therapeutic fluid: A review. *Int J Mol Sci*. 2023; 24: 3420. DOI: 10.3390/ijms24043420
7. Vozel D, Božič D, Jeran M, et al. Autologous platelet- and extracellular vesicle-rich plasma is an effective treatment modality for chronic postoperative temporal bone cavity inflammation: Randomized controlled clinical trial. *Front Bioeng Biotechnol*. 2021; 9: 677541. DOI: 10.3389/fbioe.2021.677541

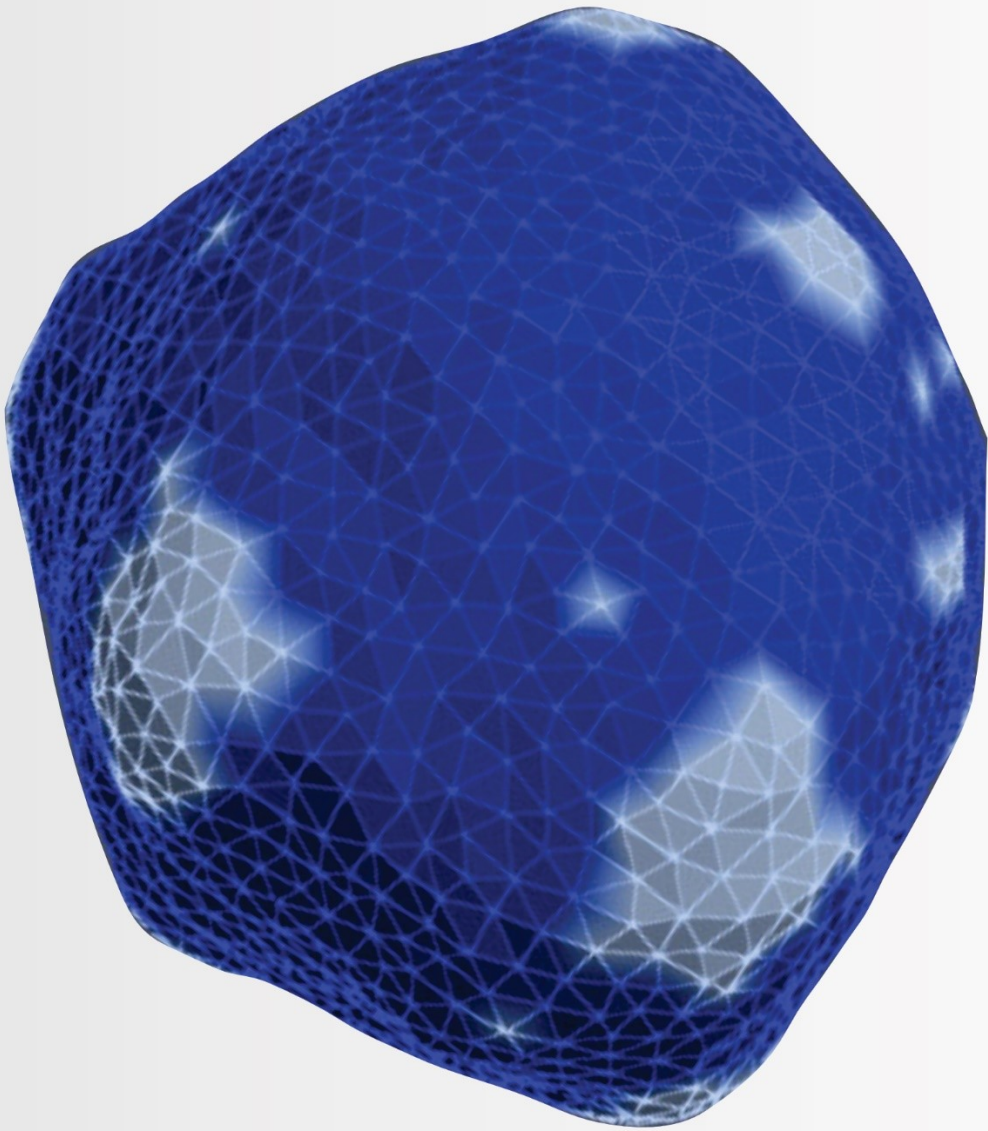



Invited lecture/Review

Effects of Capacitive and Resistive Electric Transfer Therapy on Skin Temperature - Literature Review

Bec Sergeja¹, Weber Daša¹, Vauhnik Renata¹

¹ University of Ljubljana, Faculty of Health Sciences, Ljubljana, Slovenia

* Correspondence: Sergeja Bec, bec.sergeja@gmail.com

Abstract:

Capacitive resistive energy transfer is a form of diathermy with lower frequency, approximately 0.5 MHz. It is used in clinical practice as deep thermotherapy with capacitive and resistive mode. The purpose of the review is to determine the thermal effects of capacitive resistive energy transfer and two modes on tissue temperature in healthy adults. Literature review has been conducted in databases: PubMed, CINAHL and PEDro until the end of 2022. Ten studies were included. Two studies compared capacitive and resistive energy transfer to control and six studies to placebo. In three studies a comparison was made between the capacitive and resistive modes. Capacitive and resistive energy transfer in combination or alone is safe and effective as a form of thermotherapy. Participant's subjective feeling should be that of thermal comfort.

Citation: Bec S, Weber D, Vauhnik R. Effects of capacitive and resistive electric transfer therapy on skin temperature – literature review. Proceedings of Socratic Lectures. 2023, 8; 59-65.
<https://doi.org/10.55295/PSL.2023.II10>

Publisher's Note: UL ZF stays neutral with regard to jurisdictional claims in published maps and institutional affiliations.

Keywords: Capacitive resistive energy transfer, CRET, Thermal effects, Temperature



Copyright: © 2023 by the authors. Submitted for possible open access publication under the terms and conditions of the Creative Commons Attribution (CC BY) license (<https://creativecommons.org/licenses/by/4.0/>).



1. Introduction

Thermotherapy is often used in physiotherapy for relieving pain and inflammation, as well as enhance tissue healing (Cameron, 2018; Kumaran et Watson, 2015). A rise in temperature for 1 °C increased tissue metabolism for 10–15 % (Nadler et al., 2004) and greater rise in temperature (3–4 °C) can also change physical properties of connective tissue, making it more extensible (Cameron, 2018; Kumaran et Watson, 2015). Thermotherapy can be divided into superficial and deep thermotherapy. The most commonly used form of deep thermotherapy is diathermy that uses electromagnetic field from 3 kHz to 3000 MHz (Cameron, 2018; Bryś et al., 2022). The most widely used is short-wave diathermy with 27,12 MHz (Cameron, 2018).

Recently, devices that use lower frequency are becoming available and are used in clinical practice (Kumaran et Watson, 2021). Capacitive and resistive energy transfer (CRET) therapy uses radiofrequency of approximately 0.5 MHz (Tashiro et al., 2017) and has two treatment modes: capacitive (CAP) and resistive (RES) (Clijisen et al., 2020). The devices have two different active electrodes and a metal plate to close the circuit (Barassi et al., 2022). CAP electrode has a coating layer, that prevents the direct contact of metal to the skin and enables heat generation in superficial water-rich tissue e.g., adipose tissue and lymphatic system (Clijisen et al., 2020). RES electrode doesn't have an insulating layer, so the energy goes directly through the body and generates heat in tissues with less water e.g., bone, joint capsules and tendon (Beltrame et al., 2020; Clijisen et al., 2020).

Two systematic reviews described CRET therapy in rehabilitation and clinical practice and sports (Beltrame et al., 2020; De Sousa-De Sousa et al., 2021), but have not specifically investigated the thermal effects of CRET or the differences between CAP and RES. The purpose of this literature review is to determine effects of CRET and each treatment mode (RES and CAP) on tissue temperature in healthy population.

2. Methods

Literature review has been conducted until the end of the year 2022 in databases: PubMed, CINAHL and PEDro with terms: capacitive resistive, capacitive-resistive, CRET, tecar, radiofrequency therapy, radiofrequency treatment and temperature.

Randomized controlled trials (RCT) in English language that investigated the effects of radiofrequency therapy (frequency up to 0.5 MHz) on skin or tissue temperature in healthy participants were included. Studies on cadavers and animals, or studies that used radiofrequency for aesthetic purposes or ablation were excluded.

3. Results

A total of 10 articles were included (Bito et al., 2020; Bryś et al., 2022; Clijisen et al., 2020; Fousekis et al., 2020; Kumaran et Watson, 2015; Kumaran et Watson, 2018; Tashiro et al., 2017; Yeste-Fabregat et al., 2021; Yokota et al., 2017; Yokota et al., 2018). There was a total of 189 participants. In two studies (Kumaran et Watson, 2018; Yokota et al., 2018) they compared CRET to control and in six studies (Bito et al., 2020; Fousekis et al., 2020; Kumaran et Watson, 2018; Tashiro et al., 2017; Yeste-Fabregat et al., 2021; Yokota et al., 2017) to placebo therapy. Three studies (Bito et al., 2020; Clijisen et al., 2020; Kumaran et Watson, 2015) compared effects of RES and CAP mode of treatment between each other. Six studies had cross-over design (Clijisen et al., 2020; Fousekis et al., 2020; Kumaran et Watson, 2015; Kumaran et Watson, 2018; Tashiro et al., 2017; Yokota et al., 2017).



Table 1: Study characteristics and parameters of treatment.

Author, Year	Sample	Average age ± SD (years)	Experimental condition	Parameters (treatment duration, intensity, plate/active electrode placement)
Yokota et al., 2018	22 M	23.0 ± 1.3	G1: CRET (n = 11)	5 min CAP and 10 min RES
		23.2 ± 2.3	G2: control (n = 11)	Subjective Anterior thigh/posterior thigh
Kumaran et Watson, 2018	7 M 10 W	45.7 ± 5.4	G1: thermal CRET	5 min CAP and 10 min RES
			G2: non-thermal CRET	Subjective
			G3: placebo CRET	Calf/anterior thigh
			G4: control	
			G5: PSWD	
Yeste-Fabregat et al., 2021	32 M	22.8 ± 5.9	G1: CRET (n = 17)	10 min CAP and 15 min RES
			G2: placebo CRET (n = 15)	40 % peak device power Shin/medial part of calf
Fousekis et al., 2020	10 M	22 ± 3	G1: CRET	5 min CAP and 10 min RES
			G2: CRET with Fascia Tools	Subjective
			G3: placebo CRET	Not reported/posterior thigh
			G4: placebo CRET s Fascia Tools	
Tashiro et al., 2017	13 M	24.5 ± 3.0	G1: CRET	5 min CAP and 10 min RES
			G2: thermopack	Subjective
			G3: placebo CRET	Stomach/lower part of paraspinal muscles
Yokota et al., 2017	8 M 5 W	22.0 ± 0.8	G1: CRET	5 min CAP and 10 min RES
			G2: thermopack	Subjective
			G3: placebo CRET	Anterior thigh/posterior thigh
Bitto et al., 2020	27 W	74.6 ± 5.4	G1: CRET (n = 10)	5 min CAP and 10 min RES
			G2: thermopack (n = 9)	Subjective
			G3: placebo CRET (n = 8)	Stomach/thorax posteriorly
Kumaran et Watson, 2015	6 M 9 W	45.1 ± 11.6	G1: RES	Until thermal discomfort
			G2: CAP	Subjective Calf /anterior thigh
Bryś et al., 2022	15 M 15 W	24 ± 1	G1: CAP (n=15)	10 min each mode (RES and CAP)
			G2: RES (n=15)	35 % → RES: 70 VA, CAP: 69 W Posterior thigh/anterior thigh
Clijssen et al., 2020	6 M 4 W	35.9 ± 10.7	G1: RES	8 min each mode (RES and CAP)
			G2: CAP	Subjective
			G3: placebo CRET	Back in level of scapula/anterior part of forearm

CAP – capacitive, CRET – capacitive resistive energy transfer, G – group, M – men, RES – resistive, SD – standard deviation, W – women



Table 2: Effects of CRET on skin and tissue temperature.

Author, year	Instrument	Results	
		Within group	Comparison between groups
Yokota et al., 2018	Infrared thermometer	↑ ST ($p < 0.05$) immediately after treatment (5.1°C), 15 minutes after (1.9°C) and 30 minutes after (1.7°C) CRET.	↑ ST immediately after and 15 and 30 minutes after CRET in comparison to control ($p < 0.05$)
Kumaran et Watson, 2018	Physiological measurement system	No side effects. ↑ ST ($p < 0.05$) immediately after (power: 42.37 ± 4.64 W) and 20 minutes after CRET.	↑ ST after thermal CRET in comparison to control ($p < 0.05$) and placebo ($p < 0.05$).
Yeste-Fabregat et al., 2021	Thermography	↑ ST immediately after ($p < 0.05$), but not 15 and 30 minutes after CRET.	↑ ST after CRET immediately after in comparison to placebo ($p < 0.05$), but not 15 and 30 minutes after.
Fousekis et al., 2020	Infrared thermometer	↑ ST (10.5 %) immediately after ($p < 0.05$) ↑ ST lasted for 55 minutes after CRET.	↑ ST after CRET in comparison to placebo ($p < 0.05$)
Tashiro et al., 2017	Electronic noninvasive thermometer	Average Δ ↑ in ST: 3.8°C , TT10mm: 3.2°C and TT20mm: 3.6°C immediately after CRET. Average Δ ↑ in ST: 1.6°C , TT10mm: for 2°C and TT20mm: 1.9°C 30 minutes after CRET.	↑ average Δ in ST, TT10mm and TT20mm immediately after and 30 minutes after CRET in comparison to placebo ($p < 0.05$)
Yokota et al., 2017	Electronic noninvasive thermometer	Average Δ ↑ in ST: 2.4°C , TT10mm: 2.3°C and TT20mm: 3.3°C immediately after CRET. Average Δ ↑ in ST: 1.5°C , TT10mm: 1.5°C and TT20mm: 2.3°C 30 minutes after CRET.	↑ average Δ in ST, TT10mm and TT20mm immediately after CRET in comparison to placebo ($p < 0.05$)
Bito et al., 2020	Infrared thermometer	Average Δ ↑ ST: 0.7°C ($p > 0.05$), TT10mm: 2.8°C and TT20mm: 3.6°C ($p < 0.05$) immediately after CRET.	Average Δ in ST ↑ TT10mm and TT20mm immediately after CRET in comparison to placebo ($p < 0.05$).
Kumaran et Watson, 2015	Infrared thermometer	No side effects. ↑ ST with RES for 12.7 % ($p < 0.05$) and with CAP for 11.1 % ($p < 0.05$) until the feeling of thermal discomfort (power: 32.4 ± 11.8 W for CAP and 81.5 ± 20.1 W for RES). ↑ ST lasted 45 minutes after treatment for RES and CAP ($p < 0.05$).	The temperature at the point of thermal discomfort was the same after RES and CAP, but this threshold was achieved faster after CAP. The temperature dropped faster after CAP. ↑ ST after RES in comparison to CAP after 45 minutes ($p < 0.05$).
Bryś et al., 2022	Thermo camera	↑ ST after RES ($p < 0.05$) and CAP ($p < 0.05$) immediately after and 5 and 10 minutes after CRET.	↑ ST immediately after and 5 and 10 minutes after RES in comparison with CAP ($p < 0.05$).
Clijssen et al., 2020	Infrared thermography	No side effects. Average Δ ↑ ST after RES for 2.8°C and after CAP for 1°C (p value is not reported).	↑ ST after RES in comparison to placebo ($p < 0.05$), but not in comparison to CAP.

CAP – capacitive, CRET – capacitive resistive energy transfer, ↑ - higher, RES – resistive, ST – skin temperature, TT10mm – tissue temperature 10 mm under skin, TT20mm – tissue temperature 20 mm under skin.



In eight studies they used Indiba® device with peak power of 200 W (450 VA) and frequency of 448 kHz. In one study they used Tecar T-Plus Wintecare® (Clijsen et al., 2020) and in one T-CARE TECAR® (Yeste-Fabregat et al., 2021) with peak device power of 300 W and 0.5 MHz frequency. The treated body parts and electrode placement differed between studies. In studies that investigated effects of CRET combining RES and CAP only one study (Yeste-Fabregat et al., 2021) determined a longer treatment time of 25 minute (15 minutes CAP and 10 minutes RES), and the others used almost standardized time of 15 minutes (5 minutes CAP and 10 minutes RES). In most studies the intensity of treatment was set according to participants feeling of thermal comfort. Based on manufacturer's advice a 6 or 7 on scale from 0 to 10 (Kumaran et Watson, 2015; Tashiro et al., 2017). Only two studies (Bryś et al., 2022; Yeste-Fabregat et al., 2021) determined intensity based on percent of peak device power. Parameters of CRET and each mode are summarized in Table 1.

In all studies skin temperature was measured and in three studies (Bito et al., 2020; Tashiro et al., 2017; Yokota et al., 2017) they also measured temperature 10 and 20 millimeters below skin surface. They measured temperature on the treatment area before and right after treatment and 10 (Bryś et al., 2022) to 45 minutes (Kumaran et Watson, 2015) after treatment.

In all studies CRET therapy and each mode (RES and CAP) provided higher skin temperature by the end of the treatment and effects lasted even after the treatment. The rise in the skin temperature was higher in CRET groups as compared to the control and placebo groups. Detailed results are reported in Table 2.

4. Discussion

All studies, except one (Bito et al., 2020) that researched the thermal effects of CRET (5 minutes of CAP and 10 minutes of RES) on superficial tissue, showed skin temperature increase. Bito and colleagues (2020) studied effects on older adults. Older adults have less amount of water in skin and subcutaneous tissue and thinner skin with less vessels (Farage et al., 2007; Lorenzo et al., 2019), which may be the reason they did not see effects on skin temperature. On the other hand, Bito and colleagues (2020) along with Tashiro and colleagues (2017) and Yokota and colleagues (2017) have provided evidence of thermal effects 10 and 20 millimeters under skin surface, which might indicate that thermal effects could be present also in older adults. The rise in skin temperature in the end of the treatment ranged between 2.4°C and 5.1 °C in adults, but only 0.7 °C in older adults. The rise in temperature under skin surface was between 2.8 °C and 3.6 °C in adults and older adults. Higher skin temperature lasted even 30 minutes after the treatment, the difference from before treatment was around 1.5 °C (Tashiro et al., 2017; Yokota et al., 2017). Fousekis and colleagues (2020) reported that higher skin temperature lasted for 55 minutes after treatment. Higher temperature was maintained in deeper tissues as well, around 2 °C 30 minutes after treatment (Tashiro et al., 2017, Yokota et al., 2017). It is important to consider that for these longer lasting effects, the intensity had to be set according to subjective perception of heat in participants. Yeste-Fabregat and colleagues (2021) did see effects on skin temperature immediately after treatment, but not 15 or 30 minutes later. They were the only ones that set the intensity according to 40 % of peak device power. This intensity may have not been enough to get results even if the treatment was longer (25 minutes) than others. Manufacturers of CRET devices advise that level of intensity for should be of thermal comfort around 6 or 7 on scale from 0 to 10 (Kumaran et Watson, 2015).

Both treatment modes (CAP and RES) have been shown to be effective for increasing skin temperature (Bito et al., 2020; Clijsen et al., 2020; Kumaran et Watson, 2015) even for more than 1°C. The increase in the temperature lasted 10 and 45 minutes after the treatment in both modes. When the intensity was set based on participant's perception, there was no difference between the rise in skin temperature between the modes. Changes in the skin temperature were achieved faster with CAP mode, meaning with less power than RES (Clijsen et al., 2020; Kumaran et Watson, 2015). Thermal effect 45 minutes after the treatment was bigger when using RES than CAP mode (Kumaran et Watson, 2015). Results support the developer's claim that RES and CAP modes induce different tissue responses, with CAP having more superficial and RES deeper response, but there is a need for studies that would investigate this with the measurements in deeper tissue.

These differences between CAP and RES modes require caution when comparing effects of treatments done on different body parts and different electrode placement. The amount



of heat generated in tissue depends on conductivity, strength of electromagnetic field, size of the electrodes and anthropometric factors (Kumaran et Watson, 2015) as well as the treatment mode. For better comparability, studies should report use power in the treatment and not only participant's subjective perception.

CRET has been shown to be more effective than control immediately after treatment (Yeste-Fabregat et al., 2021; Yokota et al., 2018) and 30 minutes after treatment (Yokota et al., 2018). CRET was more effective in comparison to placebo treatment (Bito et al., 2020; Fousekis et al., 2020; Kumaran et Watson, 2018; Tashiro et al., 2017; Yeste-Fabregat et al., 2021; Yokota et al., 2017), where the skin temperature dropped, because of the cold electrode (Bito et al., 2020). These findings confirm that the increase in tissue temperature is not random or solely from moving the electrode on the skin, but is due to the CRET treatment. Because none of the studies reported any side effects, CRET can be considered as a safe treatment.

5. Conclusion

A fifteen-minute CRET treatment combining RES and CAP mode is safe and effective form of thermotherapy in healthy adults when intensity is set according to subjective perception of thermal comfort. When combining both modalities the thermal effects are superficial and deep. However more research is needed for understanding the effects in the deeper tissue. Further research should focus on how different parameters and participants characteristics affect changes in thermal effects.

Conflicts of Interest: The authors declare no conflict of interest.

References

1. Barassi G, Mariani C, Supplizi M, et al. Capacitive and Resistive Electric Transfer Therapy: A Comparison of Operating Methods in Non-specific Chronic Low Back Pain. *Adv Exp Med Biol.* 2022; 1375: 39-46. DOI: 10.1007/5584_2021_692
2. Beltrame R, Ronconi G, Ferrara PE, et al. Capacitive and resistive electric transfer therapy in rehabilitation: a systematic review. *Int J Rehabil Res.* 2020; 43: 291-298. DOI: 10.1097/MRR.0000000000000435
3. Bito T, Suzuki Y, Kajiwara Y, et al. Effects of deep thermotherapy on chest wall mobility of healthy elderly women. *Electromagn Biol Med.* 2020; 39: 123-128. DOI: 10.1080/15368378.2020.1737803
4. Bryś K, Grabarek BO, Król P, Staszkiwicz R, Wierzbik-Strońska M, Król T. The Thermal Influence of an Electromagnetic Field with a Radio Frequency Depending on the Type of Electrode Used. *Int J Environ Res Public Health.* 2022; 19: 11378. DOI: 10.3390/ijerph191811378
5. Cameron M. H., Diathermy. In: *Physical Agents in Rehabilitation: An Evidence-Based Approach to Practice*, 5th Edition. Elsevier. 2018; pp. 641-702.
6. Clijisen R, Leoni D, Schneebeli A, et al. Does the Application of Tecar Therapy Affect Temperature and Perfusion of Skin and Muscle Microcirculation? A Pilot Feasibility Study on Healthy Subjects. *J Altern Complement Med.* 2020; 26: 147-153. DOI: 10.1089/acm.2019.0165
7. De Sousa-De Sousa L, Tebar Sanchez C, Maté-Muñoz JL, et al. Application of Capacitive-Resistive Electric Transfer in Physiotherapeutic Clinical Practice and Sports. *Int J Environ Res Public Health.* 2021; 18: 12446. DOI: 10.3390/ijerph182312446
8. Farage MA, Miller KW, Elsner P, Maibach HI. Structural characteristics of the aging skin: a review. *Cutan Ocul Toxicol.* 2007; 26: 343-357. DOI: 10.1080/15569520701622951
9. Fousekis K, Chrysanthopoulos G, Tsekoura M, et al. Posterior thigh thermal skin adaptations to radiofrequency treatment at 448 kHz applied with or without Indiba® fascia treatment tools. *J Phys Ther Sci.* 2020; 32: 292-296. DOI: 10.1589/jpts.32.292
10. Kumaran B, Watson T. Thermal build-up, decay and retention responses to local therapeutic application of 448 kHz capacitive resistive monopolar radiofrequency: A prospective randomised crossover study in healthy adults. *Int J Hyperthermia.* 2015; 31: 883-895. DOI: 10.3109/02656736.2015.1092172
11. Kumaran B, Watson T. Skin thermophysiological effects of 448 kHz capacitive resistive monopolar radiofrequency in healthy adults: A randomised crossover study and comparison with pulsed shortwave therapy. *Electromagn Biol Med.* 2018; 37: 1-12. DOI: 10.1080/15368378.2017.1422260



12. Kumaran B, Watson T. Thermophysiological responses to capacitive resistive monopolar radiofrequency electromagnetic radiation in patients with osteoarthritis of the knee joint: A randomised controlled experimental study. *Electromagn Biol Med.* 2021; 40: 210-221. DOI: 10.1080/15368378.2020.1846556
13. Lorenzo I, Serra-Prat M, Yébenes JC. The Role of Water Homeostasis in Muscle Function and Frailty: A Review. *Nutrients.* 2019; 11: 1857. DOI: 10.3390/nu11081857
14. Nadler SF, Weingand K, Kruse RJ. The physiologic basis and clinical applications of cryotherapy and thermotherapy for the pain practitioner. *Pain Physician.* 2004; 7: 395-399.
15. Tashiro Y, Hasegawa S, Yokota Y, et al. Effect of Capacitive and Resistive electric transfer on haemoglobin saturation and tissue temperature. *Int J Hyperthermia.* 2017; 33: 696-702. DOI: 10.1080/02656736.2017.1289252
16. Yeste-Fabregat M, Baraja-Vegas L, Vicente-Mampel J, Pérez-Bermejo M, Bautista González IJ, Barrios C. Acute Effects of Tecar Therapy on Skin Temperature, Ankle Mobility and Hyperalgesia in Myofascial Pain Syndrome in Professional Basketball Players: A Pilot Study. *Int J Environ Res Public Health.* 2021; 18: 8756. DOI: 10.3390/ijerph18168756
17. Yokota Y, Tashiro Y, Suzuki Y, et al. Effect of Capacitive and Resistive Electric Transfer on Tissue Temperature, Muscle Flexibility, and Blood Circulation. *J Nov Physiother.* 2017; 7: 325–331. DOI: 10.4172/2165-7025.1000325
18. Yokota Y, Sonoda T, Tashiro Y, et al. Effect of Capacitive and Resistive electric transfer on changes in muscle flexibility and lumbopelvic alignment after fatiguing exercise. *J Phys Ther Sci.* 2018; 3: 719-725. DOI: 10.1589/jpts.30.719

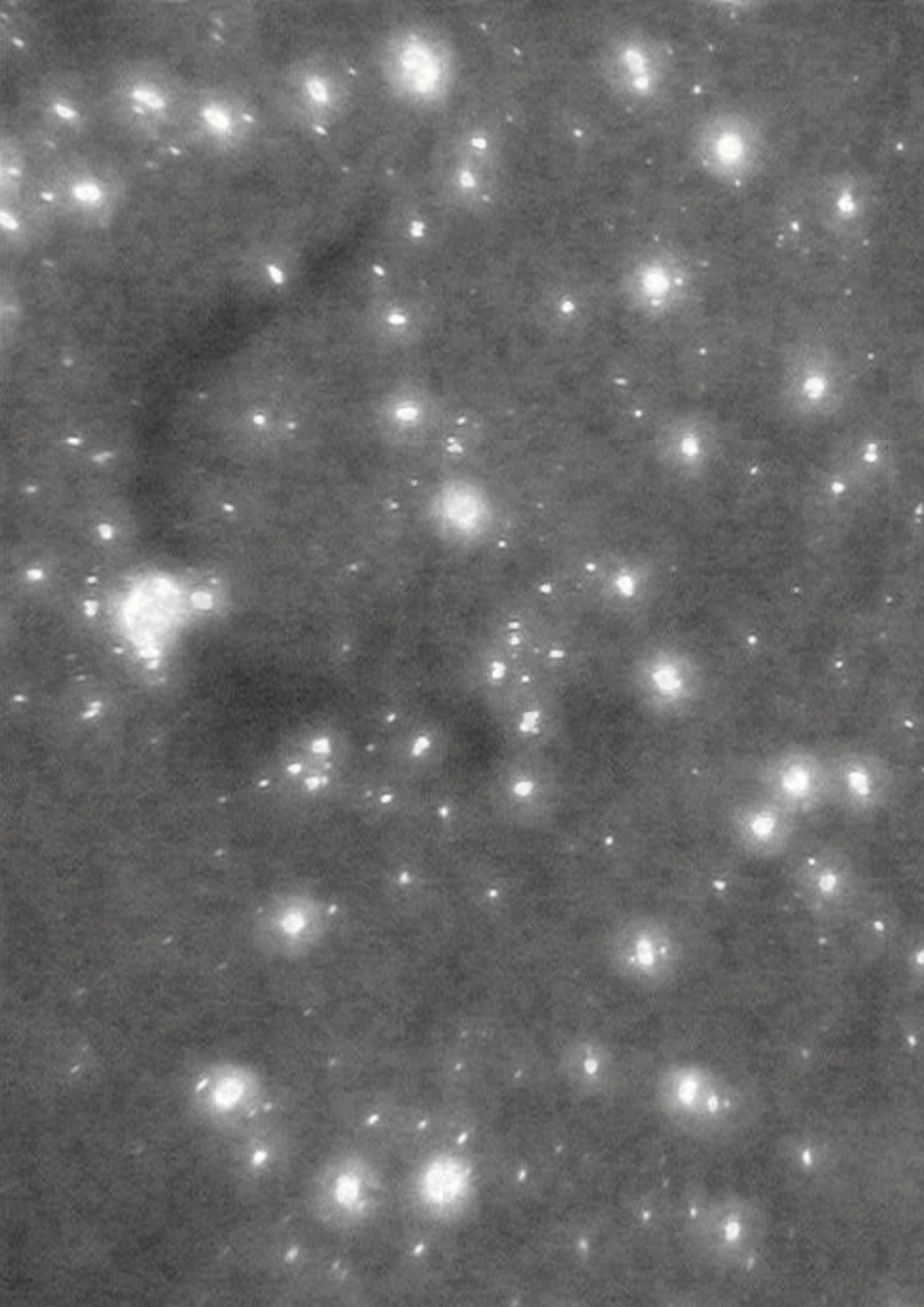



Scientific contribution

Electronic Blood Sedimentation Monitoring with Microcontroller and Linear CCD Sensor

Penič Samo^{1,*}, Iglič Aleš¹, Kralj-Iglič Veronika²

- ¹ Laboratory of Physics, Faculty of Electrical Engineering, University of Ljubljana, Ljubljana, Slovenia
² Laboratory of Clinical Biophysics, Faculty of Health Sciences, University of Ljubljana, Ljubljana, Slovenia
* Correspondence: Samo Penič; samo.penic@fe.uni-lj.si

Citation: Penič S, Iglič A, Kralj-Iglič Veronika. Electronic blood sedimentation monitoring with microcontroller and linear CCD sensor. Proceedings of Socratic Lectures. 2023, 8; 67-72.
<https://doi.org/10.55295/PSL.2023.II11>

Publisher's Note: UL ZF stays neutral with regard to jurisdictional claims in published maps and institutional affiliations.



Copyright: © 2023 by the authors. Submitted for possible open access publication under the terms and conditions of the Creative Commons Attribution (CC BY) license (<https://creativecommons.org/licenses/by/4.0/>).

Abstract

Modern electronics can be utilized to provide automated means of monitoring spontaneous blood sedimentation and by implementing wireless power and data transfer can be used in centrifugation systems as well. Here, we present the method of building the optical linear charge coupled device (CCD) sensor with microcontroller circuit for recording and monitoring the sedimentation process. Brief overview of the engineering behind the communication protocol is given together with key microcontroller techniques that are required for fast analogue voltage signal sampling. Proposed system has adaptable light integration protocol and shows exceptional durability under centrifugal force loads that are commonly used in platelet-rich plasma. The parts for building the system are sourced at common electronics stores and provides easy means for observing optical changes in blood samples with emphasis on sedimentation and forming layers with different optical properties.

Keywords: Blood sedimentation; Plasma; Platelet-rich plasma; Microcontroller; Optical sensor

1. Introduction

For faster wound healing, the application of blood without erythrocytes (plasma) to the injured tissue is used as an effective method (Daif 2013, Božič et al. 2022). Appropriately prepared plasma is used, which has an increased concentration of platelets relative to the initial concentration in the blood before the preparation (Vozel et al. 2021a).

When treating patients with platelet-rich plasma, a sufficient volume of blood must be drawn from the patient. Using laboratory centrifuges, which allow relatively low centrifugal accelerations, we increase the platelet concentration in the isolate compared with the total blood sample (Božič et al., 2022). During centrifugation, the erythrocytes settle at the bottom of the vessel, leaving above platelet-rich plasma (supernatant), however, the profile of the platelets in plasma depends on the dynamics of the system. Sedimentation of erythrocytes concentrates them towards the bottom of the tube which induces formation of rouleaux and therefrom channels that enable movement of plasma with smaller particles (including platelets) in the opposite direction. In this way the compartment above the erythrocyte boundary gets enriched with platelets and extracellular vesicles. Eventually, the centrifugal force causes sedimentation of platelets and concentrates them in the layer at the boundary between erythrocytes and plasma. During this process the distribution of platelets along the length of the plasma column is changing. On the other hand, leukocytes are accumulated at the boundary between erythrocytes and plasma (Figure 1).

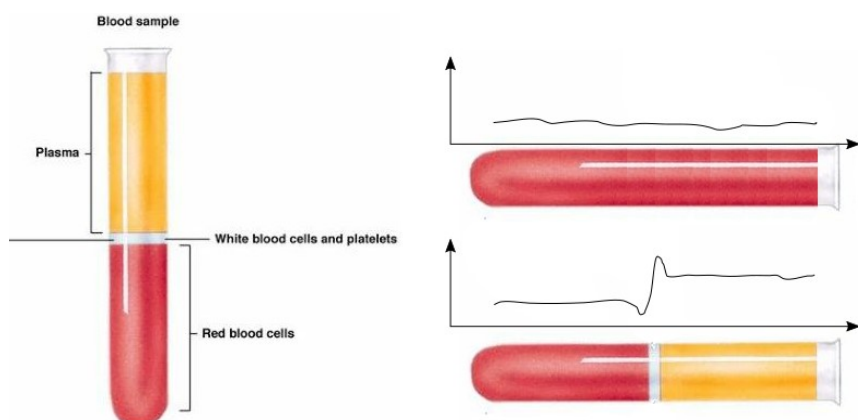

Figure 1. Blood sedimentation. At the bottom, there is a sediment of red blood cells, the platelet-rich layer and plasma (left). Different layers have different opacities; thus we can detect the layers with optical sensors (right). Above the epruvettes, a hypothetical signal is depicted.

Centrifuge parameters such as acceleration and centrifugation time strongly influence how the different blood particles in the sample will move under the influence of the centrifugal force. The blood of different patients may differ in composition and thus in its physical and chemical properties resulting in different sedimentation times. Parameters can be experimentally determined and mathematical models based on previous isolation protocols which could predict the settings of the centrifugation process have been developed (Chahla et al. 2017, Božič et al., 2022). The erythrocyte sedimentation time is crucial in the separation of erythrocytes from plasma as it provides a source of counterflow of platelets which is at the same time diminished when platelets are found in plasma devoid of erythrocytes. Mathematical modelling indicated that there is an optimal time to enrich plasma with platelets and extracellular vesicles and that this takes place when erythrocyte boundary that moves towards the bottom of the tube coincides with boundary of platelets and extracellular vesicles that moves in the opposite direction (Božič et al., 2022). Further centrifugation may deplete plasma of platelets and extracellular vesicles. To test the model and enable optimization of the procedure, it would be of interest to follow the boundary of erythrocytes during preparation of plasma.

Within this work, we will present the development of an automated centrifuge module and tool for measuring spontaneous sedimentation, based on red blood cell settlement monitoring with the S11108 complementary metal-oxide-semiconductor CMOS linear CMOS sensor from Hamamatsu (Figure 2). Most of the development consists in the con-

struction of an electronic module for communication between microcontroller and the optical sensor. The microcontroller system is based around the ST Microsystems STM32F103 family microcontroller and, in addition to processing the sensor data, it takes care of deciding on a sufficient centrifugation time. It records the light transmission through the sample and in this way gives valuable insights to the researcher about the sedimentation process.

2. Methods

For prototyping, the linear CCD sensor Hamamatsu S11108 was chosen. Test tube (Vacutainer) containing the blood sample is inserted between the sensor and light emitting diode (LED) light source. The blood is illuminated with light source and the intensity of the transmitted light is recorded with an array of optical receptors. The Hamamatsu S11108 sensor has an array of 2048 photodiodes of size $14 \times 14 \mu\text{m}$ on an active sensor length of 28.672 mm. This length is comparable to the length of Vacutainer tube. The signal generated by individual photodiodes/photoreceptors is relative to the light intensity and can be read at a frequency of 200 kHz to 10 MHz per pixel. The supply voltage is 5 V and the current consumption during operation at the lowest frequency is only 10 mA. The sensor is sensitive to light in the visible part of the spectrum between 400-1000 nm, with peak sensitivity at 700 nm. The video signal is linear between 0,3 V for dark point and 1,2-1,7 V for fully light saturated point.

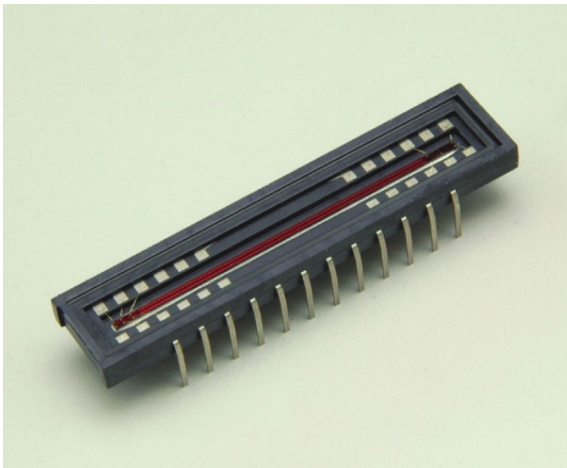

Figure 2. Hamamatsu S11108 linear CCD optical sensor with 2048 photoreceptors that form a single image of the light intensity in the test tube.

The communication protocol that sends data about pixel intensities is simple and is shown in time diagram in **Figure 3**. The sensor expects a digital clock signal which defines the temporal information to its electronics. Depending on the clock frequency, the light integration time during which the photoreceptors receive the light signal can be set by adjusting number of clock cycles. The frequency of image acquisition can be altered by changing the clock frequency. In addition to the clock signal, the sensor needs information when to start integration and send the data to the outside world. This is achieved by a start signal (denoted as ST in time diagram). Its length is important for setting the integration time, but it also triggers the shifting of the video signal at the sensor output. The sensor also generates a trigger signal (Trig) which can be used to synchronise with an analogue-to-digital translator. The end of the data transmission is indicated by an Electro – Optics – System (EOS) signal.

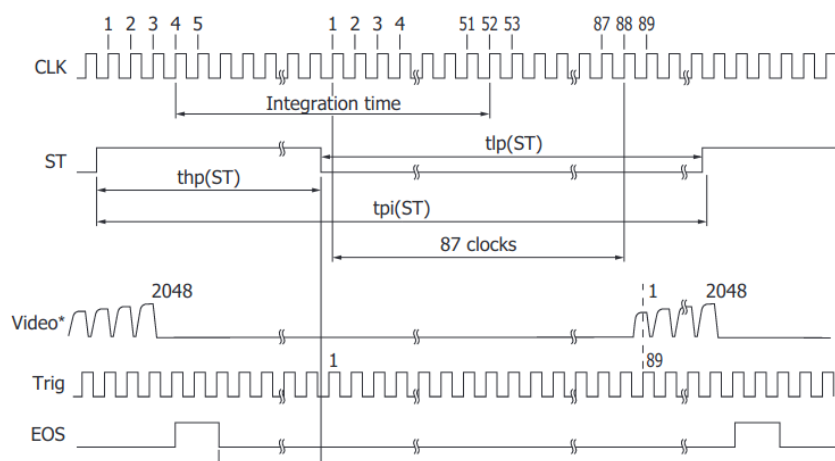

Figure 3. Timings of the communication protocol between CCD sensor and controlling circuit with all the required signals and their time durations in units of clock cycles. The actual time to read the whole image depends on the clock frequency and can vary substantially on this value.

The STM32F103 microcontroller on the well-known “Blue pill” (see **Figure 4**) development board was used to implement the communication protocol with the sensor and communication with the computer. The microcontroller has a universal set of timers which can be used to implement a clock signal for the sensor and a properly synchronised signal to start sending video data. Two timers are used which are connected in series; the first, TIM1, performs the task of a clock generator for the sensor, divides the processor clock and generates a 200 kHz digital signal at the output of the microcontroller by activating the Output compare function. At the same time, it triggers an internal event for the second timer TIM2, which uses the frequency of the first one to generate the ST signal. The output of the second timer generates a pulse width modulated digital signal at the output. The pulse length determines the integration time of the sensor.

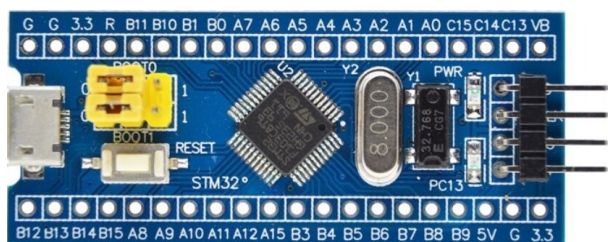

Figure 4. “Blue pill” development board with STM32F103 microcontroller on the board. The small microcontroller is fast enough to process the data output by the CCD sensor.

The analogue output signal of the sensor is fed to the input of an analogue-to-digital converter (ADC). The ADC can be operated at a maximum sampling rate of 500 kHz and can write the conversion results directly to microcontroller memory using a direct memory access (DMA) that requires no computational power from the microprocessor part. To run the analogue-to-digital conversions of the ADC, a trigger signal from the sensor was used, which tells when the video signal at the sensor output is ready for capture and is slightly lagging the sensor clock.

The timers and the ADC are configured to do their work independently of the processing unit and thus do not consume processor cycles. When the ADC finishes filling the memory and captures the entire image of the line scan sensor, an interrupt is triggered to tell the main processor that new data is available. These are processed and sent via USB to the computer.

3. Results

The system was developed in ST Microelectronics integrated development environment called STM Cube. The resulting communication between the sensor and microcontroller was observed by means of digital oscilloscope, ensuring all the timings and frequencies are correct and within the sensor specifications. The test of the sensor was done by illuminating Vacutainer tube containing different fluids and observing the voltage responses by oscilloscope and by examining data sent by the system to the computer. We have defined a threshold below which the measurement is considered to be opaque, giving us discrete information about how translucent is the material.

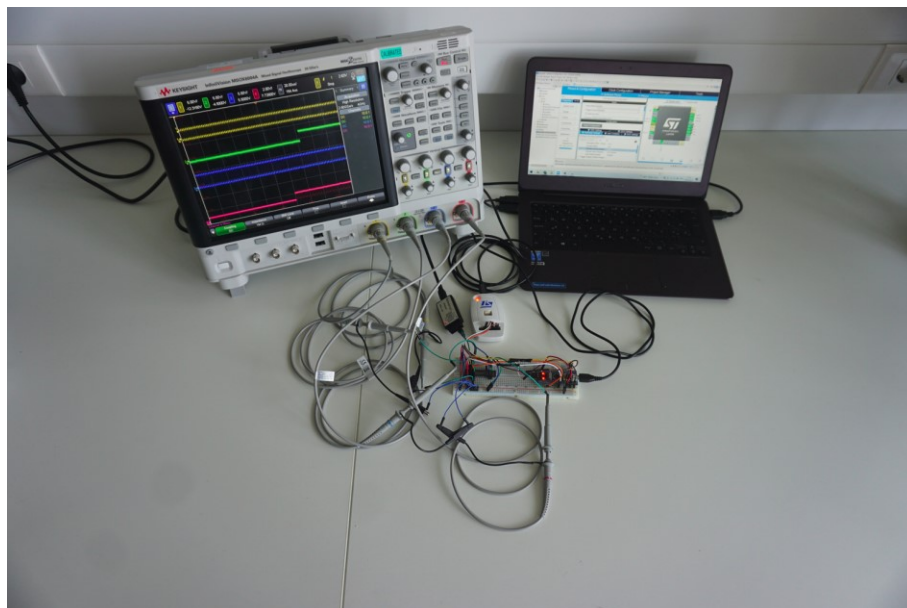

Figure 5. Testing the CCD sensor communication with microcontrollers with oscilloscope and computer. The development software running on the computer is used to reprogram the microcontroller board on the prototype board.

An important test was a durability test of the sensor in strong centrifugal force environment to determine the possibility of the sensor integration with centrifuge and observing sedimentation during the process of centrifugation. In **Figure 6**, the microscope image of the sensor endpoints, where the bonding wires are attached to the silicon die, connecting the silicon with the outside world is shown. Thin wires are prone to breakage, therefore, we tested how they react under force. We exposed the sensor to gradually increasing centrifugal force of 10g, 50g, 100g, 400g and 600g and noted no deformation on the wires or any other part of the sensor. After the stress test, the sensor continued normal operation and showed no degradation of the performance.

4. Discussion

We have developed and tested a conceptual design for the construction of an optical detector for observing the spontaneous blood sedimentation with possibility to integrate it into centrifuge to observe the sedimentation while the sample is exposed to high centrifugal forces. The key to the final application is the detection of the time dependence of the movement of the erythrocyte boundary. If the centrifugation process is too long, the platelets are depleted from plasma and the efficiency of the platelet-rich plasma protocol is lost. The centrifugation time is strongly dependent on the physical and chemical parameters of the blood and can be determined in advance based on the information on the movement of the boundary.

Several open problems remain in the development process of centrifuge integration. A wireless communication with the centrifuge is supposed to be used, since the sensor is mounted on a rotor that rotates during operation, relative to the other electronics of the centrifuge. At the same time, power supply power to the sensor during operation will need

to be provided, which in the first version will be done using a rechargeable battery. In a practical implementation, it would be reasonable to take advantage of the fast motion of the sensor on the rotor and try to power the sensor by means of electromagnetic induction. However, the sensor will be valuable to estimate the sedimentation properties of erythrocytes also outside the centrifuge, to be inserted into mathematical model for estimation of the optimal centrifuge setting.

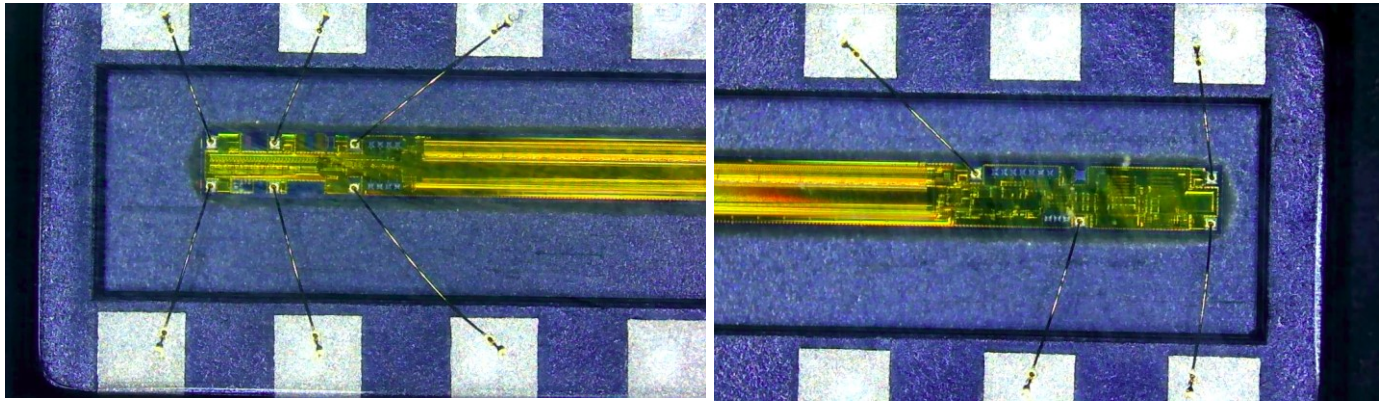

Figure 6. Microscope image of the sensor parts, where it interconnects with the outside world. After stress test, no deformation of the sensor was noted.

Funding: This research was funded by the Slovenian Research Agency, grant numbers P2-0232, P3-0388, J3-3066 and J2-4447.

Conflicts of Interest: The authors declare no conflict of interest.

References

1. Božič D, Vozel D, Hočevar M, et al. Enrichment of plasma in platelets and extracellular vesicles by the counterflow to erythrocyte settling. *Platelets*. 2022; 33: 592–602. DOI: 10.1080/09537104.2021.1961716.
2. Chahla J, Cinque ME, Piuzzi NS, et al. A call for standardization in platelet-rich plasma preparation protocols and composition reporting: a systematic review of the clinical orthopaedic literature. *J Bone Joint Surg Am*. 2017; 99: 1769–1779. DOI: 10.2106/JBJS.16.01374
3. Daif ET. Effect of autologous platelet-rich plasma on bone regeneration in mandibular fractures. *Dental traumatology*. 2013; 29: 399–403. DOI: 10.1111/edt.12021
4. Jan Z, Drab M, Drobne D, et al. Decrease in Cellular Nanovesicles Concentration in Blood of Athletes More Than 15 Hours After Marathon. *IJN*. 2021; Volume 16: 443–456. DOI: 10.2147/IJN.S282200.
5. Vozel D, Božič D, Jeran M, et al. Autologous Platelet-and Extracellular Vesicle-Rich Plasma Is an Effective Treatment Modality for Chronic Postoperative Temporal Bone Cavity Inflammation: Randomized Controlled Clinical Trial. *Frontiers in bioengineering and biotechnology*. 2021a; 573. DOI: 10.3389/fbioe.2021.677541
6. Vozel D, Božič D, Jeran M, et al. Treatment with platelet- and extracellular vesicle-rich plasma in otorhinolaryngology-a review and future perspectives. *Advances in Biomembranes and Lipid Self-Assembly*, vol. 33. Elsevier. 2021b; pp. 119–153. DOI:10.1016/bs.abl.2020.05.003

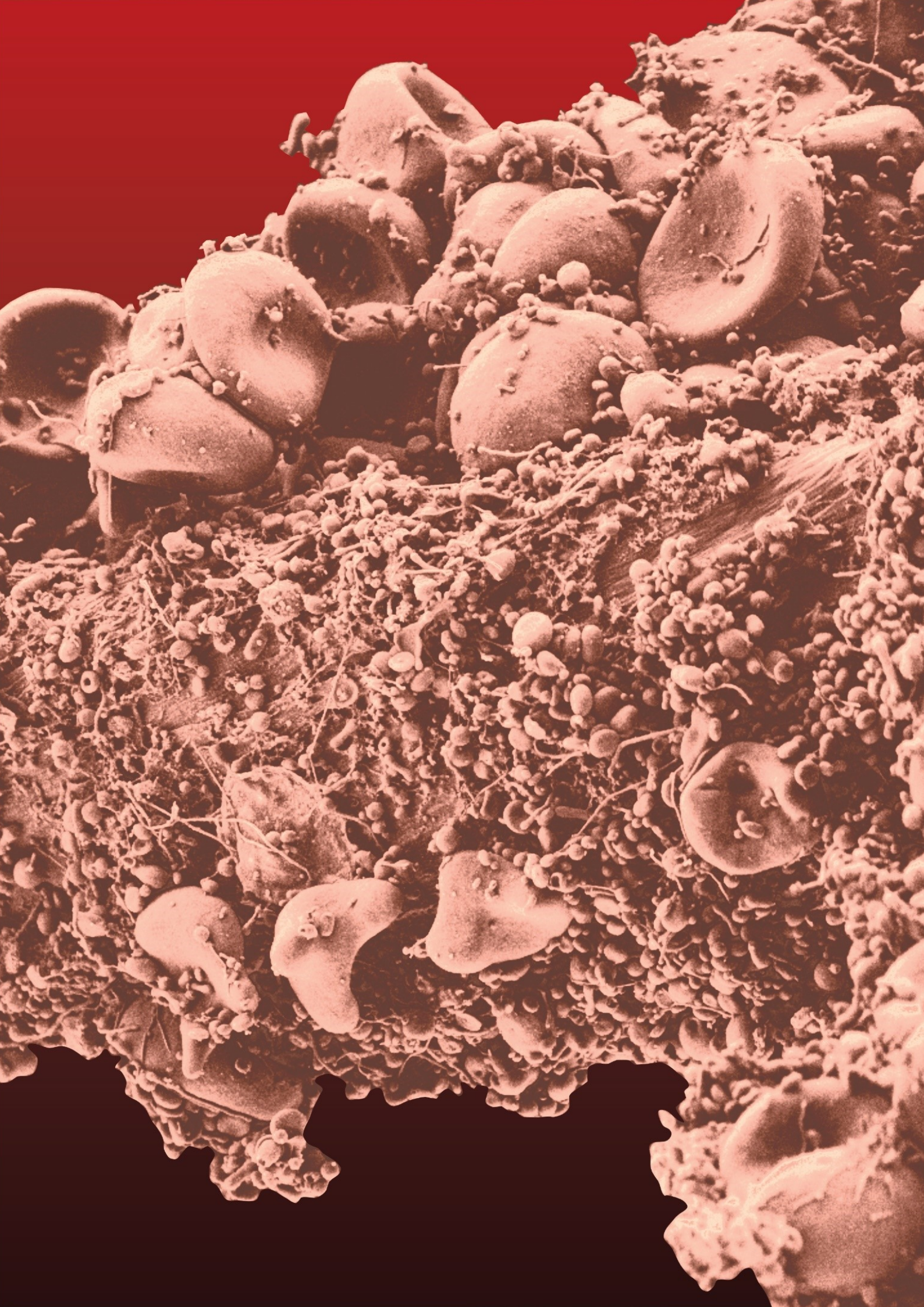

Scientific contribution

Short Term Effect of Plant Hybridosomes on Growth of *Phaeodactylum Tricornutum* Culture

Romolo Anna¹, Hočevar Matej², Iglič Aleš¹, Griessler Bulc Tjaša³,
Kralj-Iglič Veronika^{3,*}

1. University of Ljubljana, Faculty of Electrical Engineering, Laboratory of Physics, Ljubljana, Slovenia
 2. Institute for Metals and Technology, Ljubljana, Slovenia
 3. University of Ljubljana, Faculty of Health Sciences, Laboratory of Clinical Biophysics, Ljubljana, Slovenia
- * Correspondence: Veronika Kralj-Iglič; veronika.kralj-iglic@zf.uni-lj.si

Abstract:

Microalgae are in focus of extensive study due to their abundance and important role in equilibration of the global ecosystem. Living organisms communicate through nano-sized membrane-enclosed particles which are continuously shed by cells but can also be fabricated artificially. In this work we examined the effect of hybridosomes composed from soyabean lecithin, aqueous solution containing substances from spruce needles and glycerol and hybridosomes composed from soyabean lecithin, ultraclean water and hemp oil on the number density of microalgae *Phaeodactylum tricornutum* in culture. We measured the number density of microalgae by flow cytometry and the number density and hydrodynamic diameter of small particles in the samples by interferometric light microscopy. We observed considerable increase of the number density of microalgae with respect to control (untreated) samples after three days, which was connected to the amount of the material added. Addition of membrane-enclosed particles had a favourable effect on the microalgae growth. Microalgae proved a convenient system for in vitro studies of the effects of substances.

Citation: Romolo A, Hočevar M, Iglič A, Griessler Bulc T, Kralj-Iglič V.

Effect of plant hybridosomes on growth of *Phaeodactylum Tricornutum* culture. Proceedings of Socratic Lectures. 2023, 8; 74-86.

<https://doi.org/10.55295/PSL.2023.II12>

Publisher's Note: UL ZF stays neutral with regard to jurisdictional claims in published maps and institutional affiliations.



Copyright: © 2023 by the authors. Submitted for possible open access publication under the terms and conditions of the Creative Commons Attribution (CC BY) license (<https://creativecommons.org/licenses/by/4.0/>).

Keywords: *Phaeodactylum tricornutum*; Hybridosomes; Liposomes; Nanoalgorithms; Extracellular vesicles; Small cellular particles; Microalgae



1. Introduction

1.1. Small Cellular Particles (SCPs) and hybridosomes

Cells shed in their exterior SCPs (such as extracellular vesicles (EVs), lipoproteins, antibody complexes, viruses) that can move more or less freely in the surrounding medium and transport a variety of cargo to adjacent or remote cells (Herman et al., 2021, Lenzini et al., 2020). Extensive studies and empirical knowledge indicates that these tiny particles may have a great impact on living systems and mediate interactions between different life domains and kingdoms. Recent reports on the role of SCP-mediated horizontal transfer of bioactive proteins, lipids and nucleic acids (Fischer et al., 2016) in gene regulation, local phenotypic adaptation and immune evasion render SCPs as ideal candidates to serve as biomarkers, nano-sized drug-delivery vehicles, and mediators for a variety of therapeutics in oncology, immunotherapy and regenerative medicine (Yates et al., 2022, Armingol et al., 2021, Jin et al., 2021, Combarrous et al., 2020, Fais et al., 2016). Furthermore, this so-called theranostic “all-in-one approach” has potential in the field of personalised medicine, as it enables the detection and monitoring of a disease in individual patients, possibly in early clinical stages, as well as in targeted drug delivery to the required.

Recent research indicates that SCPs may play a role in the larger communication systems of multicellular organisms within endocrine, paracrine and angiocrine systems (Raposo et al., 2021), suggesting that they may be powerful and versatile tools for vaccination strategies due to their immunogenic properties, natural adjuvanticity, uptake by mammalian cells, and potential for genetic engineering (Akuma et al., 2019, van der Pol et al., 2015). Interaction between virions and SCPs have been suggested to regulate virion production, and their secretion (Mammadova et al., 2021, Badierah et al., 2021), and SCPs were found to transport different types of RNA (messenger RNAs, microRNAs, ribosomal RNAs, transfer RNAs, small RNAs and long non-coding RNAs) (Turchinovich et al., 2019; Shao et al., 2018) and DNA (Elzanowska et al., 2021). It was found that SCPs transfer short RNAs from plant to pathogen cells and trigger host-induced gene silencing, a mechanism that allows the regulation of gene expression of the invading pathogen or parasite (Cai et al., 2018). Increasing evidence suggests that beneficial abilities of mesenchymal stem cells can be attributed to their paracrine secretion of SCPs and that administration of small particles that contain a mixture of proteins, lipids, and nucleic acids, resembling the secretome of mesenchymal stem cells, can mimic most of the effects of the parental cells (Herman et al., 2021). Furthermore, SCPs can be efficiently delivered to the respiratory and neural systems through inhalation thereby offering the advantage of non-invasive and repeated administration (Frolich, 2021).

1.2. Nanoalgosomes – SCPs from natural sources

We have recently considered microalgae as a promising source of deliverosomes. Microalgae constitute a rich reservoir of bioactive metabolites such as pigments, polyunsaturated fatty acids, antioxidants or antimicrobial compounds, which are being increasingly exploited in commercial ventures (Cuellar-Bermudez et al., 2015). Many microalgae species are suitable for growth in industrial scale photobioreactors and are seen as highly productive crops when compared with terrestrial plants (Khan et al., 2018). As microalgae cells have high growth rates, they can be cultured on non-arable land under controlled environmental conditions (Koller et al., 2012), so that large scale production of SCPs with algal technologies seems feasible (Paganini et al., 2019). Their natural and sustainable origin grants them a likely greater societal acceptance (with reduced sensitive ethical questions). SCPs called nanoalgosomes were isolated from cultured media of microalgae *Tetraselmis chuii* and characterized (Adamo et al., 2021). Nanoalgosomes did not show significant toxicity on the tumorigenic MDA-MB-231 breast cancer, non



tumorigenic 1–7 HB2 and Hep G2 cell lines over time and at different concentrations in a specific dose- and time-dependent manner (Adamo et al., 2021). The genotoxicity assay showed no DNA damage or apoptotic events and cultured cells were able to uptake nanoalgosomes (Adamo et al., 2021). However, the yield of the nanolagosomes in *Tetraselmis chuii* and in particular, their protein content was rather low which indicates that harvesting of the nanoalgosomes should be boosted to reach a scale production required for therapeutic use.

1.3. SCPs from plants

The hemp plant contains an enormous variety of chemicals (ElSohly and Slade, 2005). Recent studies report more than 1200 different compounds, out of which there are about 140 terpenes, about 50 flavonoids and more than different cannabinoids/phytocannabinoids (Andre et al., 2016). The term cannabinoids represents a group of C21 or C22 terpenophenolic compounds found in *Cannabis sativa* L (Mechoulam and Gaoni, 1967). Hemp plants contain levels of psychoactive molecules under regulatory levels so the products are considered safe to use as food, food supplements, or cosmetics. Cannabinoids are highly hydrophobic lipids, almost insoluble in water (Guzman, 2003) but show good solubility in different organic solvents, such as methanol and ethanol (Smith and Vaughan, 1977). Of these, cannabidiol (CBD) in low doses exhibited antioxidant and neuroprotectant (Hayakawa et al., 2010; Hampson et al., 1998), anti-inflammatory (Burstein, 2015), anti-emetic (Parker et al., 2011) and antipsychotic (Zuardi et al., 2012) effects.

Spruce bark is known to be a rich source of terpenes, but also of polyphenols, resin acids, flavonoids, stilbenes and stilbene glucosides, lignin, holocellulose, β -sitosterol and methyl dehydroabietate, with some of these substances having antibacterial and antioxidant properties (Jeran et al., 2022). Polyphenols are compounds with one or more hydroxyl groups attached to the benzene ring, which give them the ability to capture free radicals, moreover it gives them a stronger acidic character in comparison to other alcohol groups and therefore antioxidant properties (Nisca et al., 2021). Needles contain mono- and sesquiterpenes, fatty acids, phenolic compounds, stilbene glucosides, waxes and carbohydrates as well as long-chain alcohols, e. g. nonacosan-10-ol, which has superhydrophobic properties (Bukhanko et al., 2020). Jokinen and Sipponen (2016) reported that a complex mixture of spruce resin acids lignans showed antimicrobial, wound healing, and skin regeneration effects.

1.4. Liposomes

Above the critical micelle concentration, lipid molecules aggregate and form larger structures such as micelles, inverted micelles, or bilayers (Lombardo, 2015). The propensity for the membrane depends on the shape of the constituents (Israelachvili, 2015; Igljč et al., 2015). The technique for bilayer vesicle production can influence the final properties of hbridsomes, such as size, lamellarity, and encapsulation efficiency (Pattni et al., 2015). The most common methods to prepare lipid vesicles are thin film hydration, reverse phase evaporation and solvent injection (Karn et al., 2013; Meure et al., 2008), and electroformation (Drab et al., 2021). In order to be up-taken by cells, deliverosomes should be small (i.e. submicron-sized). Larger vesicles therefore require additional processing to reduce their size, such as sonication, extrusion, microfluidization, high-pressure homogenization, or shear force-induced homogenization (Guimaraes et al., 2021; Wagner and Vorauer-Uhl, 2011). In extrusion, the vesicles pass several times (extrusion cycles) through a membrane of defined pore size, to render the size distribution more uniform (Meure et al., 2008; Olson et al., 1979).



1.5. Hybridosomes

Formation of hybridosomes by processing material from natural sources and lipids is expected to capture the substances of the natural sources with health-beneficial effects, increase the yield and render material with better controlled properties.

In this work we report on preparation of three types of small particles: liposomes composed of lecithin, water and glycerol, and two types of hybridosomes where natural compounds from hemp and spruce were added. We characterized these particles with respect to number density and size. To assess their effect *in vivo* we added these particles to the culture of microalgae *Phaeodactylum tricornutum* and followed their number density and the number density of small particles in the conditioned media for 6 days.

2. Methods

2.1. Cultivation of microalgae

Culture of *Phaeodactylum tricornutum* CCAP 1052/1A was from the Culture Collection of Algae and Protozoa (CCAP) of SAMS (Oban, Scotland). The culture was grown in mineral water Radenska Naturelle (Ca 59, Mg 20, Na 6.9, K 0.7, HCO₃⁻ 280, Cl 5.0 SO₄ 1.1, F<0.2 in borosilicate glass bottle. Edible salt (Droga, Portorož, Slovenia) was added to the mineral water in proportion 22 g of salt per one litre of mineral water. Salt was previously sterilized by heating over 80 °C in the microwave oven. Mineral water with added salt was supplemented with Guillard's (F/2) Marine Water Enrichment Solution (ref. G0154, Sigma Aldrich, USA) in proportion 20 mL of F/2 per one litre of mineral water with added salt. Culture was grown in a room at 18 °C with natural light. The aliquots for the experiment were taken at Day 18 after inoculation of microalgae into the bottle.

2.2. Design of the experiment with microalgae

Microalgae culture were aliquoted into Petri dishes, in triplicates for each added compound (hybridosomes from spruce needles and hybridosomes from hemp oil) and for controls (liposomes from soya lecithin and untreated samples). Each type of samples was kept in a separate box. The number density of microalgae, the number density of SPs in the culture and the number density of hybridosomes/liposomes were measured before the addition of the compounds to the microalgae. 2 mL of culture was put in each Petri dish. At Day 0 we added 20 µL of dissolved hybridosomes or liposomes to the samples. The boxes were placed in a room at 18 °C and exposed to natural light. At days 1,2,3 and 6 we gently mixed the samples by circular motion of the boxes and took 200 µL of the conditioned media for measurements by FCM and ILM. We have replenished the volume of the samples by ultraclean water with added salt and f/2.

2.3. Preparation of spruce needle homogenate

Branches were cut from the *Picea abies* tree and used immediately. Branches were immersed into 1.5 L of water at 30 °C with 10 mL of sodium hypochlorite (NaClO, 0.1 %) for 1 hour. The branches were rinsed with water. The needles were cut off from the branches. 50.0 g of wet needles were immersed in 300 mL of ultraclean water and stirred for 1 minute in KOIOS 850W Smoothie Bullet Blender (KOIOS, Neweg, USA). The homogenate was filtered through 0.5 mm nylon net cloth to remove larger particles.

2.4. Isolation of SCPs from spruce needle homogenate

SCPs were isolated by differential centrifugation, using a protocol widely used for the isolation of small extracellular vesicles (Mantille et al., 2022). Briefly, the cells and larger particles were removed by low-speed centrifugation (300 g, 10 min, 4°C, centrifuge Centric 260R with rotor RA 6/50 (Domel, Slovenia)), using 50 mL conical centrifuge tubes (ref. S.078.02.008.050, Isolab Laborgeräte GmbH, Germany); and 2000 g, 10 min, 4°C (Centric 400R centrifuge with rotor RS4/100 (Domel, Slovenia)), using 15 mL conical centrifuge



tubes (ref. S.078.02.001.050, Isolab Laborgeräte GmbH, Germany). Each step was repeated twice. Then, the cell-depleted medium was centrifuged at 10 000 g and 4°C for 30 min (Beckman L8-70M ultracentrifuge, rotor SW55Ti (Beckman Coulter, USA)), using thin-wall polypropylene centrifuge tubes (ref. 326819, Beckman Coulter, USA). The pellet was resuspended in 50 µL of ultraclean water.

2.5. Preparation of hybridosomes

Hybridosomes were prepared by mixing appropriate proportions of lyophilized soya lecithin granules with ultraclean water/supernatant of isolation of SCPs from spruce needle homogenate and oily glycerol/hemp oil, at room temperature. Three samples were prepared. Sample A contained 33 weight % of soya granules, 33 % of ultraclean water and 33% of glycerol; sample B contained 33 weight % of soya granules, 33% of supernatant of centrifugation of homogenate from spruce needles at 300g I and 33% of glycerol, and sample C contained 33% of soya granules, 33% ultraclean water and 33% of hemp oil. Soyabean lecithin granules were placed into the falcon tubes. Water or supernatant was added and the suspension was left at room temperature for 1 hour. Glycerol or hemp oil was added and the samples were mixed mechanically (manually) with metallic stick until the ingredients formed a uniform cream-line consistence. The samples were kept at room temperature.

2.6. Flow Cytometry (FCM)

The microalgae number densities were measured by flow cytometry by a MACSQuant Analyzer flow cytometer (Miltenyi Biotec, Bergisch Gladbach, Germany) and the related software. The following instrument settings were employed: FSC: 458 V; SSC: 467 V with a trigger set to 1.48, B3: 300 V; R1: 360 V. Particles were detected from the forward (FSC) and side scatter parameter (SSC). Samples were mixed by pipetting before measurement and 20,000 events per well were acquired. We have also measured number densities of hybridosomes for which the samples were diluted 1000 × with ultraclean water.

2.7. Interferometric Light Microscopy (ILM)

The average hydrodynamic diameter (D_h) and the number density of small particles in the conditioned media and in hybridosome/liposome preparations were determined by interferometric light microscopy using Videodrop (Myriade, Paris, France). The conditioned media were measured undiluted while the hybridosome/liposome preparations were diluted 1000 ×. Signals of the media (salted mineral water supplemented by F/2) were under the detection limit. The threshold value 4.2 was used. 7 µL of sample was placed between cover glasses and illuminated by 2W blue LED light. The light scattered on the particle was imaged by a bright-field microscope objective and allowed to interfere with the incoming light. The image was recorded by a complementary metal-oxide-semiconductor high resolution high speed camera. The obtained pattern that includes contrasting black and white spots was recognized as a particle and its position in the sample was assessed. Number density of the particles is the number of the detected particles within the detected volume (e.g. 15 pL). D_h was determined by tracking the position of the imaged particle within the recorded movie. It was assumed that particles undergo Brownian motion due to collisions with surrounding particles. The diffusion coefficient D of the motion of the particle is taken to be proportional to the mean square displacement d of the particle between two consecutive frames taken in the time interval Δt , $\langle d^2(\Delta t) \rangle = \langle 4D \Delta t \rangle$ while D_h was estimated by assuming that the particles were spherical and using the Stokes-Einstein relation $D_h = kT/3\pi\eta D$. Each particle that was included in the analysis was tracked and processed indi-

vidually and the respective incident light signal was sub-tracted from each image. Processing of the images and of the movies was performed by using the associated software QVIR 2.6.0 (Myriade, Paris, France).

2.8. Statistical analysis

All measurements were performed in triplicates and presented by the average values and standard deviations. Correlations between variables were assessed by the Pearson correlation coefficient and the respective probability. The value $p = 0.05$ was taken as a threshold for statistical significance.

3. Results

Figures 1A shows microalgae *Phaeodactylum tricornutum*. The cells are in fusiform shape. **Figures 1B** shows their SCPs in conditioned media. Numerous SCPs are relatively homogeneous in shape and size (smaller than 100 nm in diameter). The mechanism of formation of these SCPs remains obscure. **Figure 1C** shows shows cryo-TEM image of liposomes composed of soya lecithin, water and glycerol and **Figure 1D** shows cryo-TEM images of hybridosomes composed of soya lecithin, supernatant of 300 g sedimentation of homogenate from spruce needles and glycerol. It can be seen by comparing Figures 1E and 1F that the particles are of similar shapes and sizes.

To observe the effect of hybridosomes on the growth of microalgae, we initially planted 2 mL of culture in each Petri dish and each day we subtracted 200 μL of the culture for measurement by FCM, light microscopy observation and ILM. To maintain the same volume of the sample, 200 μL of mineral water with added salt and $f/2$ was replenished to each Petri dish. The number densities of hybridosomes and liposomes in the added suspensions are given in Table 1.

Table 1. Number density and hydrodynamic diameter D_h of hybridosomes and liposomes in the suspension that was added to microalgae cultures

Sample	Number density by FCM (/μL)	Number density by ILM (/μL)	D_h (nm)
Hemp hybridosomes	114 ± 21	$(5.47 \pm 10) \times 10^5$	224 ± 13
Spruce hybridosomes	46 ± 5	$(2.01 \pm 11) \times 10^5$	249 ± 10
Liposomes	240 ± 13	$(3.89 \pm 10) \times 10^5$	363 ± 9

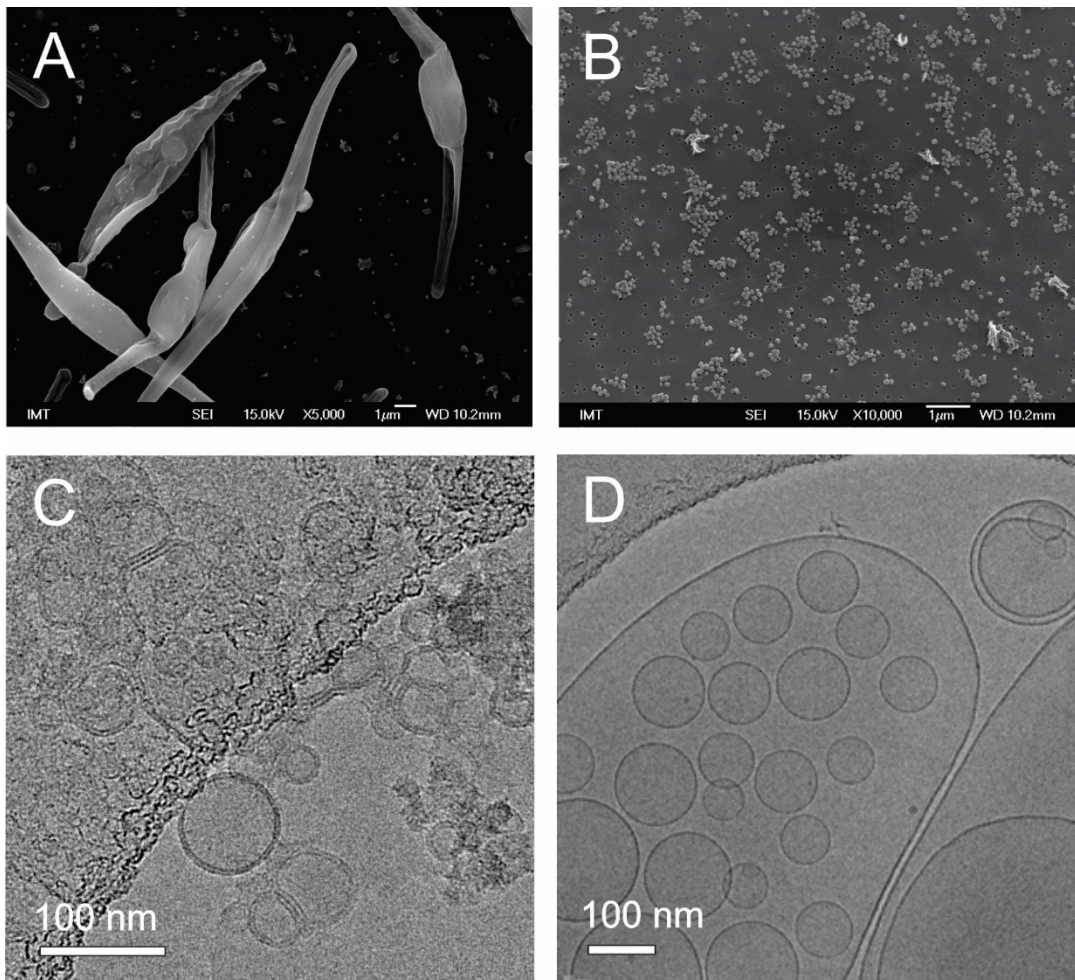

Figure 1. **A:** SEM images of Microalgae *Phaeodactylum tricornutum*, **B:** SEM image of SCPs in conditioned media of *Phaeodactylum tricornutum*, **C:** Cryo-TEM image of hybridosomes composed of lecithin, supernatant after 300 g centrifugation of spruce needles homogenate and glycerol, **D:** Cryo-TEM image of liposomes composed of soya lecithin, water and glycerol. A,B: From C: From Jeran et al., (2023). D: From Romolo et al., (2022).

Addition of liposomes to the culture of *Phaeodactylum tricornutum* caused a short-term increase of the number density of microalgae (Figure 2A) as it can be seen in **Figure 2A** that the number density of microalgae has increased considerably with respect to the baseline the first two days after the addition of hybridosomes to the culture. Hybridosomes of both types also showed increase after two days while the number density remained more or less constant in the control samples (**Figure 2A**). In the following days, the number densities of the microalgae in all the samples were unified. A possible reason for this is the presence of small microorganisms in the samples which were visible under the light microscope. A fibrous network with dilatations was noted, however, these organisms did not swim. Number density of small particles was considerably higher in the samples with added liposomes and hybridosomes than in the control samples (**Figure 2B**). The number densities of SPs remained constant during the experiment (green curve in **Figure 2B**).

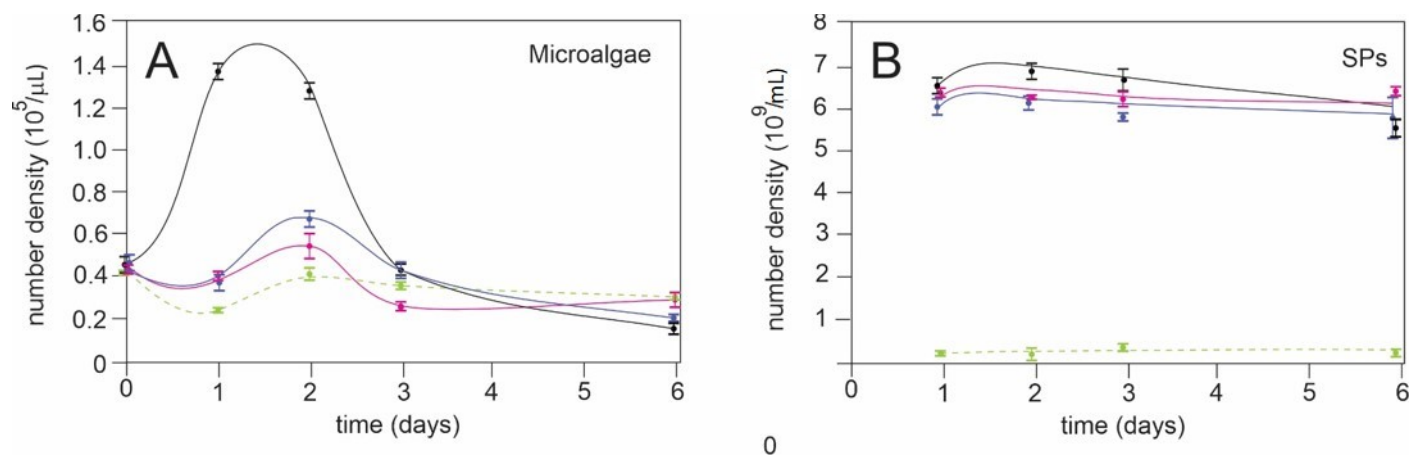

Figure 2. Number density of microalgae (A) and small particles (SPs) (B) in dependence on time. Magenta: samples with added hemp hybridosomes, blue: sample with added spruce hybridosomes, black: samples with added liposomes, green: control samples.

Average hydrodynamic diameters of small particles in the samples were different (**Figure 3**). In the samples with more numerous particles the particles had larger D_h . The Pearson coefficient of the correlation taking into account 20 samples was 0.62 with probability 0.0046.

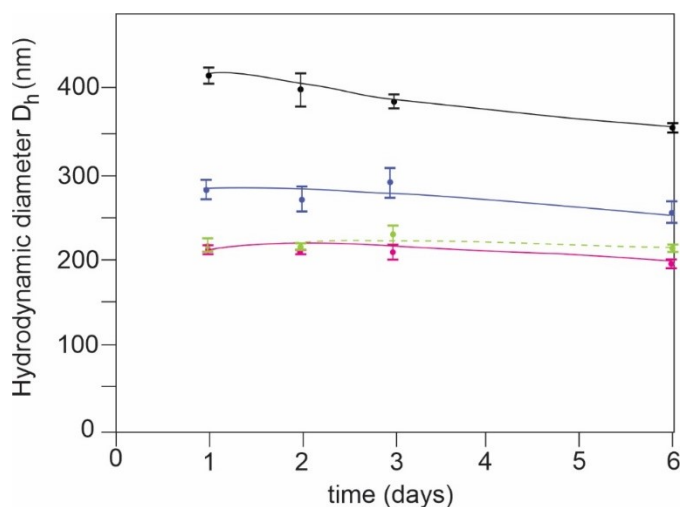

Figure 3. Hydrodynamic diameter of small particles (SPs) in the samples of microalgae with added hybridosomes. Magenta: samples with added hemp hybridosomes, blue: sample with added spruce hybridosomes, black: samples with added liposomes, green: control samples.

4. Discussion

We have observed the effect of added liposomes and hybridosomes on the growth of *Phaeodactylum tricoratum* in culture. We found that the addition of hybridosomes promoted the growth of microalgae in the first two days. The results indicate that the effect was larger if the initial number density of the added particles was larger (**Figure 2**). Microalgae were found a convenient culture to study the in-vivo effects as the test samples showed considerable difference with respect to the control (untreated) samples in the interval of one day. The microalgae growth was hindered after two days as they and the accompanying microorganisms have become overcrowded in the Petri dishes. In the next experiments, larger dishes should be provided to allow for the expansion of all organisms in the samples



and therefore longer observation time. Microorganisms are naturally present in the microalgae samples and it is indicated that the optimal way of coexistence should be sought. Better characterization of the material added is also necessary. Liposomes and hybridosomes are kept at room temperature in the state of a creamy substance. This substance is not readily dissolved in aqueous media and therefore the dosage of the material is subject to large errors.

Due to their small size and heterogeneous composition of samples, and the transient identity of some types of SCPs, their harvesting and assessment remains a significant challenge. Presently, integration of different methods is recommended (They et al., 2018), however, new technically advanced solutions are urgently needed. The most commonly used method for EV harvesting involves differential centrifugation (Kirbas et al., 2019; They et al., 2006), which can be followed by gradient ultracentrifugation for example on continuous or discrete sucrose or iodixanol gradient (Iwai et al., 2016). As this technique is time consuming and is of limited capacity, alternative techniques have also been proposed. Ultrafiltration, field-flow fractionation, dialysis, size exclusion chromatography (SEC), microchip-based techniques and precipitation-based methods, alone or in combination with ultra-centrifugation-based methods. Immunoaffinity-based isolations are used to harvest SCPs with particular surface protein compositions (Beekman et al., 2019). Recently, a number of commercial kits have been made available. Ion exchange chromatography (Kosonović et al., 2018) is intended to the fast and cost effective SCP capturing from large volumes of diluted suspensions. However, different isolation methods were found to lead to different EV preparations (Freitas et al., 2019, Tian et al., 2019, Skotland et al., 2017) reflecting the fact that the techniques applied are invasive enough to transform them to such an extent that identification of their original nature is obscured. As they are very small, SCPs are hidden within the organisms or cell assemblies. They are observed in isolates and not in their natural environment. Commonly used SCP imaging methods are scanning and transmission electron microscopy (SEM and TEM, respectively), cryo TEM and atomic force microscopy (AFM) which require invasive preparation procedures. Physico-chemical techniques widely used in EV research that measure the properties, including morphology and particle size distribution are flow cytometry, light scattering, fluorescence microscopy with analysis of Brownian motion (nanoparticle tracking analysis), assesment of zeta potential and tunable resistive pulse sensing. EVs contain genetic material (different types of RNA, in particular microRNA, and DNA), proteins, lipids and other small molecules (Hartjes et al., 2019) that are analyzed by HPLC-MS/MS-based shotgun workflows that typically lead to the identification from several hundred to several thousands of units with interpretation depending on the data banks. Proteins in SCP samples separated by gel electrophoresis are assessed by Western Blot or specific immunosorbent assays. Different harvesting methods yield SCPs and SCP sub-fractions of variable homogeneity and purity that is often inadequate for downstream structural and functional analysis, resulting in SCP databases of poor data quality. Different extraction methods are applied to prepare samples for different high resolution molecular profiling studies of specific molecular classes (omics) (Pocsfalvi et al., 2016a, 2016b) with troublesome integration of the data. Orthogonal single-particle platforms with diverging results cannot be valued one above the other as there is presently no reference method outlined (Arab et al., 2021). The existing methods to harvest, identify and characterise SCPs urgently need improvement to achieve analytical level and adequate repeatability which calls for new approaches to SCP structural and functional assessment and interpretation of the data. Interference light microscopy is a recently developed methods and there are not many reports published on its use for assessment of SCPs. To our best knowledge, it has hitherto been applied to marine and river microorganisms (Boccaro et al., 2016, Roose-Amsaleg, 2017), viruses (Turkki et al., 2021) and extracellular vesicles isolated from blood plasma (Sabbagh et al., 2021). Recently, the methods was applied to different types of SPs (extracellular vesicles isolated from suspension above in vitro aged washed erythrocytes, extracellular vesicles isolated from



plasma, small cellular particles isolated from conditioned culture media of *Phaeodactylum tricornutum* and of *Tetraselmis chuii*, small cellular particles isolated from spruce needle homogenate, liposomes made from soya lecithin, water and glycerol and hybridosomes made from soya lecithin, supernatant from isolation of SCPs from spruce needle homogenate and glycerol (Romolo et al., 2022). The statistically significant positive correlation between the number density and size of SCPs could be a consequence of the presence of fibrous microorganisms observed in the samples. Namely, the fibrils hinder the movement of the particles and in samples with high number density the motion of the particles deviates from Brownian motion. In samples with higher number densities the displacements recorded by the video are therefore smaller due to hindered motion and hence, the diffusion coefficient also smaller. As the hydrodynamic diameter is calculated from the Stokes-Einstein equation in which D_h is inversely proportional to the diffusion coefficient, D_h can be overestimated in dense samples. The presence of fibrous microorganisms additionally contributes to this effect. With more studies presented by using the interference light microscopy, these relations will expectedly become clearer, however, it is indicated that positive correlation between the size and number density of particles detected by interferometric light microscopy may indicate direct interactions between particles in the samples.

Recently, it was shown that CBD and its metabolite, 7-OH-CBD (but not congeneric cannabinoid) potentially blocked SARS-CoV-2 replication in lung epithelial cells (Nguyen et al., 2022). After cellular infection, CBD and 7-OH-CBD inhibited viral gene expression and reversed some effects of SARS-CoV-2 on host gene transcription, induced interferon expression and up-regulated its antiviral signaling pathway (Nguyen et al., 2022). A cohort of human patients previously taking CBD had significantly lower SARS-CoV-2 infection incidence (up to an order of magnitude) relative to matched pairs or the general population, which implicated CBD and 7-OH-CBD as potential preventative agents and therapeutic treatments for SARS-CoV-2 at early stages of infection (Nguyen et al., 2022). Since almost 80 % of the human body consists of water, this correlates with cannabinoid low absorption rate and bioavailability, greatly hindering clinical use (Lipinski, 2002). The fabrication of membrane-enclosed nano-sized cannabinoid products is therefore of significant importance.

Funding: This research was supported by Slovenian Research Agency through the core findings No. P2-0132, P2-0232, P3-0388, P11-2358, and projects J3-3066, J2-4447 J2-4427 and L3-2621.

Institutional Review Board Statement: The study was conducted according to the guidelines of the Declaration of Helsinki.

Conflicts of Interest: The authors declare no conflict of interest.

References

1. Adamo G, Fierli D, Romancino DP, Picciotto S, et al. Nanoalgosomes: Introducing extracellular vesicles produced by microalgae. *J Extracell Vesicles*. 2021; 10: e12081. DOI: 10.1002/jev2.12081
2. Akuma P, Okagu OD, Udenigwe CC. Naturally Occurring Exosome Vesicles as Potential Delivery Vehicle for Bioactive Compounds. *Front Sustain Food Syst*. 2019; 3: 1–8. <https://doi.org/10.3389/fsufs.2019.00023>
3. Andre CM, Hausman JF, Guerriero G. Cannabis sativa: The Plant of the Thousand and One Molecules. *Front Plant Sci*. 2016; 7:19. DOI: 10.3389/fpls.2016.00019
4. Arab T, Mallick ER, Huang Y, et al. Characterization of extracellular vesicles and synthetic nanoparticles with four orthogonal single-particle analysis platforms. *J Extracell Ves*. 2021; 10: e12079. DOI: 10.1002/jev2.12079
5. Armingol E, Officer A, Harismendy O, Lewis NE. Deciphering cell-cell interactions and communication from gene expression. *Nat Rev Genet*. 2021; 22: 71–88. DOI: 10.1038/s41576-020-00292-x



6. Badierah RA, Uversky VN, Redwan EM. Dancing with Trojan horses: an interplay between the extracellular vesicles and viruses. *J Biomol Struct Dyn*. 2021; 39:30. DOI: 10.1080/07391102.2020.1756409
7. Beekman P, Encisco-Martinez A, Rho HS, et al. Immuno-capture of extracellular vesicles for individual multi-modal characterization using AFM, SEM and Raman spectroscopy. *Lab Chip*. 2019; 19: 2526-2536. DOI: 10.1039/c9lc00081j
8. Boccara M, Fedala Y, Vénien-Bryan C, Bailly-Bechet M, et al. Full-field interferometry for counting and differentiating aquatic biotic nanoparticles: from laboratory to *Tara* Oceans. *Biomed Opt Express*. 2016; 7: 3736-3746. DOI: 10.1364/BOE.7.003736
9. Božič D, Hočevar M, Jeran M *et al.* Ultrastructure and stability of cellular nanoparticles isolated from *Phaeodactylum tricorutum* and *Dunaliella tertiolecta* conditioned media. *Open Res Europe*. 2022; 2, 121. <https://doi.org/10.12688/openreseurope.14896.1>
10. Bukhanko N, Attard T, Arshadi M, Eriksson D, et al. Extraction of cones, branches, needles and bark from Norway spruce (*Picea abies*) by supercritical carbon dioxide and soxhlet extractions techniques. *Ind Crop Prod*. 2020; 145: 112096. <https://doi.org/10.1016/j.indcrop.2020.112096>
11. Burstein S. Cannabidiol (CBD) and its analogs: a review of their effects on inflammation. *Bioorg Med Chem*. 2015; 23: 1377-1385. DOI: 10.1016/j.bmc.2015.01.059
12. Cai Q, Qiao L, Wang M, He B, Lin FM, et al. Plants send small RNAs in extracellular vesicles to fungal pathogen to silence virulence genes. *Science*. 2018; 360: 1126-1129. DOI: 10.1126/science.aar4142
13. Combarnous Y, Nguyen TMD. Cell Communications among microorganisms, plants, and animals: Origin, evolution, and interplays. *Int J Mol Sci*. 2020; 21: 8052. DOI: 10.3390/ijms21218052
14. Cuellar-Bermudez SP, Aguilar-Hernández I, Cardenas-Chavez DL, et al. Extraction and purification of high-value metabolites from microalgae: essential lipids, astaxanthin and phycobiliproteins. *Microb. Biotechnol*. 2015; 8: 190-209. DOI: 10.1111/1751-7915.12167
15. Drab M, Pandur Ž, Penič S, Kralj-Iglič V, Iglič A, Stopar D. A Monte Carlo study of giant vesicle morphologies in nonequilibrium environments. *Biophys J*. 2021; 120: 4418-4428. <https://doi.org/10.1016/j.bpj.2021.09.005>
16. ElSohly MA, Slade D. Chemical constituents of marijuana: the complex mixture of natural cannabinoids. *Life Sci*. 2005; 78: 539-548. DOI: 10.1016/j.lfs.2005.09.011
17. Elzanowska J, Semira C, Costa-Silva B. DNA in extracellular vesicles: biological and clinical aspects. *Mol Oncol*. 2021; 15: 1701-1714. DOI: 10.1002/1878-0261.12777
18. Fais S, O'Driscoll L, Borrás FE, Buzas E, et al. Evidence-Based Clinical Use of Nanoscale Extracellular Vesicles in Nanomedicine. *ACS Nano*. 2016; 10: 3886-3899. DOI: 10.1021/acsnano.5b08015
19. Fischer S, Cornils K, Speiseder T, Badbaran A, et al. Indication of Horizontal DNA Gene Transfer by Extracellular Vesicles. *PLoS ONE*. 2016; 11: e0163665. DOI: 10.1371/journal.pone.0163665
20. Freitas D, Balmana M, Poças J, et al. Different isolation approaches lead to diverse glycosylated extracellular vesicle populations. *J Extracell Ves*. 2019; 8: 1621131. DOI: 10.1080/20013078.2019.1621131
21. Frolich E. Therapeutic Potential of Mesenchymal Stem Cells and Their Products in Lung Diseases-Intravenous Administration versus Inhalation. *Pharmaceutics*. 2021; 13: 232. DOI: 10.3390/pharmaceutics13020232
22. Guimaraes D, Cavaco-Paulo A, Nogueira E. Design of liposomes as drug delivery system for therapeutic applications. *Int J Pharm*. 2021; 601: 120571. DOI: 10.1016/j.ijpharm.2021.120571
23. Guzman M. Cannabinoids: potential anticancer agents. *Nat Rev Cancer*. 2003; 3: 745-755. DOI: 10.1038/nrc1188
24. Hampson A, Grimaldi M, Axelrod J, Wink D. Cannabidiol and (-)-Delta9-tetrahydrocannabinol are neuroprotective antioxidants. *Proc Natl Acad Sci*. 1998; 95: 8268-8273. DOI: 10.1073/pnas.95.14.8268
25. Hartjes TA, Mytnyk S, Jenster GW, et al. Extracellular Vesicle Quantification and Characterization: Common Methods and Emerging Approaches. *Bioengineering*. 2019; 6: 7. DOI: 10.3390/bioengineering6010007
26. Hayakawa K, Mishima K, Fujiwara M. Therapeutic Potential of Non-Psychotropic Cannabidiol in Ischemic Stroke. *Pharmaceutics (Basel)*. 2010; 3: 2197-2212. DOI: 10.3390/ph3072197
27. Herman S, Fishel I, Offen D. Intranasal delivery of mesenchymal stem cells-derived extracellular vesicles for the treatment of neurological diseases. *Stem Cells*. 2021; 39: 1589-1600. DOI: 10.1002/stem.3456
28. Iglič A, Drobne D, Kralj-Iglič V. *Nanostructures in Biological Systems: Theory and Applications*. CRC Press, Boca Raton, FL. 2015.
29. Israelachvili JN. *Intermolecular and Surface Forces*. Academic Press, London. 2015.
30. Iwai K, Minamisawa T, Suga K, et al. Isolation of human salivary extracellular vesicles by iodixanol density gradient ultracentrifugation and their characterizations. *J Extracell Ves*. 2016; 5: 1-17. <https://doi.org/10.3402/jev.v5.30829>
31. Jeran M, Pečan LI, Barrios-Francisco R. Interdisciplinary Insight on European Spruce (*Picea abies*): Biologically Active Compounds and their Usage. *Proceedings of 6th Socratic Lectures*. 2021; 6: 64-70. <https://doi.org/10.55295/PSL.2021.D.009>



32. Jeran M, Romolo A, Spasovski V, Hočevar M, Novak U, Štukelj R, Šuštar V, Kisovec M, Bedina Zavec A, Kogej K, Igljč A, Trebše P, Kralj-Igljč V. Small Cellular Particles from European Spruce Needle Homogenate. *Int J Mol Sci.* 2023; 24, 4349. <https://doi.org/10.3390/ijms24054349>
33. Jin S, Guerrero-Juarez CF, Zhang L, Chang I, et al. Inference and analysis of cell-cell communication using CellChat. *Nat Commun.* 2021; 12: 1088. DOI: 10.1038/s41467-021-21246-9
34. Jokinen JJ, Sipponen A. Refined Spruce Resin to Treat Chronic Wounds: Rebirth of an Old Folkloristic Therapy. *Adv Wound Care.* 2016; 5: 198-207. DOI: 10.1089/wound.2013.0492
35. Karn PR, Cho W, Hwang SJ. Liposomal drug products and recent advances in the synthesis of supercritical fluid-mediated liposomes. *Nanomedicine.* 2013; 8: 1529-1548. <https://doi.org/10.2217/nnm.13.131>
36. Khan S, Fu P. Biotechnological perspectives on algae: a viable option for next generation biofuels. *Curr. Opin. Biotechnol.* 2020; 62: 146-152. DOI: 10.1016/j.copbio.2019.09.020
37. Koller M, Salerno A, Tuffner P, et al. Characteristics and potential of micro algal cultivation strategies: a review. *J. Clean. Prod.* 2012; 37: 377-388. DOI: <https://doi.org/10.1016/j.jclepro.2012.07.044>
38. Kosanović M, Milutinović B, Goč S, et al. Ion-exchange chromatography purification of extracellular vesicles. *Biotechniques.* 2017; 63: 65-71. DOI: 10.2144/000114575
39. Lenzini S, Bargi R, Chung G. et al. Matrix mechanics and water permeation regulate extracellular vesicle transport. *Nat Nanotechnol.* 2020; 15: 217-223. DOI: 10.1038/s41565-020-0636-2
40. Lipinski C. Poor aqueous solubility - An industry wide problem in drug discovery. *Am Pharm Rev.* 2002; 5: 82-85. Available at: https://www.researchgate.net/publication/279892668_Poor_aqueous_solubility_-_An_industry_wide_problem_in_drug_discovery;
41. Lombardo D, Kiselev MA, Calandra P. Amphiphiles Self-Assembly: Basic Concepts and Future Perspectives of Supramolecular Approaches. *Adv Condens Matter Phys.* 2015; pp 22. <https://doi.org/10.1155/2015/151683>
42. Łukawski M, Dałek P, Borowik T, et al. New oral liposomal vitamin C formulation: properties and bioavailability. *J Liposome Res.* 2020, 30: 227-234. DOI: 10.1080/08982104.2019.1630642
43. Mammadova R, Fiume I, Bokka R, Kralj-Igljč V, et al. Identification of Tomato Infecting Viruses That Co-Isolate with Nanovesicles Using a Combined Proteomics and Electron-Microscopic Approach. *Nanomaterials (Basel).* 2021; 11: 1922. <https://doi.org/10.3390/nano11081922>
44. Mantile F, Kisovec M, Adamo G, Romancino DP, et al. A Novel Localization in Human Large Extracellular Vesicles for the EGF-CFC Founder Member CRIPTO and Its Biological and Therapeutic Implications. *Cancers (Basel).* 2022; 14: 3700. DOI: 10.3390/cancers14153700
45. Mechoulam R, Gaoni Y. Recent advances in the chemistry of hashish. *Fortschr Chem Org Naturst.* 1967; 25: 175-213. DOI: 10.1007/978-3-7091-8164-5_6
46. Meure LA, Foster NR, Dehghani F. Conventional and dense gas techniques for the production of liposomes: a review. *AAPS Pharm Sci Tech.* 2008; 9: 798-809. DOI: 10.1208/s12249-008-9097-x
47. Nguyen LC, Yang D, Niculaesco V, et al. Cannabidiol inhibits SARS-CoV-2 replication through induction of the host ER stress and innate immune responses. *Science Advances.* 2022; 8: eabi6110. DOI: 10.1126/sciadv.abi6110
48. Nisca A, Ștefănescu R, Stegăruș DI, Mare AD, et al. Phytochemical Profile and Biological Effects of Spruce (*Picea abies*) Bark Subjected to Ultrasound Assisted and Microwave-Assisted Extractions. *Plants.* 2021; 10: 870. <https://doi.org/10.3390/plants10050870>
49. Olson F, Hunt CA, Szoka FC, et al. Preparation of liposomes of defined size distribution by extrusion through polycarbonate membranes. *BBA.* 1979; 557: 9-23. DOI: 10.1016/0005-2736(79)90085-3
50. Paganini C, Capasso Palmiero U, Pocsfalvi G, Touzet N, et al. Scalable Production and Isolation of Extracellular Vesicles: Available Sources and Lessons from Current Industrial Bioprocesses. *Biotechnol. J.* 2019; 14: 1800528. DOI: 10.1002/biot.201800528
51. Parker JA, Rock EM, Limebeer CL. Regulation of nausea and vomiting by cannabinoids. *Br J Clin Pharmacol.* 2011; 163: 1411-1422. DOI: 10.1111/j.1476-5381.2010.01176.x
52. Pattni BS, Chupin VV, Torchilin VP. New Developments in Liposomal Drug Delivery. *Chem Rev.* 2015; 115: 10938-10966. DOI: 10.1021/acs.chemrev.5b00046
53. Pocsfalvi G, Stanly C, Vilasi A, et al. Mass spectrometry of extracellular vesicles. *Mass Spectrom Rev.* 2016a; 35: 3-21. DOI: 10.1002/mas.21457
54. Pocsfalvi G, Stanly C, Fiume I, et al. Chromatography and its hyphenation to mass spectrometry for extracellular vesicle analysis. *J Chromatogr A.* 2016b; 1439: 26-41. DOI: 10.1016/j.chroma.2016.01.017
55. Prosenc F, Piechocka J, Škufca D, et al. *J Hazard Mater.* 2021; 418:126284. <https://doi.org/10.1016/j.jhazmat.2021.126284>
56. Raposo G, van Niel G, Stahl PD. Extracellular vesicles and homeostasis-An emerging field in bioscience research. *FASEB Bioadv.* 2021; 3: 456-458. DOI: 10.1096/fba.2021-00009
57. Romolo A, Jan Z, Zavec Bedina P, Kosovec M, et al. Assessment of Small Cellular Particles from Four Different Natural Sources and Liposomes by Interferometric Light Microscopy. *Int J Mol Sci.* 2022; 23: 15801.



- DOI: 10.3390/ijms232415801
58. Roose-Amsaleg C, Fedala Y, Vénien-Bryan C, Garnier J, et al. Utilization of interferometric light microscopy for the rapid analysis of virus abundance in a river. *Res Microbiol.* 2017; 168: 413-418. DOI: 10.1016/j.resmic.2017.02.004
 59. Sabbagh Q, André-Grégoire G, Alves-Nicolau C, et al. The von Willebrand factor stamps plasmatic extracellular vesicles from glioblastoma patients. *Sci Rep.* 2021; 11: 22792. DOI: 10.1038/s41598-021-02254-7
 60. Shao H, Im H, Castro CM, Breakefield X, et al. New Technologies for Analysis of Extracellular Vesicles. *Chem Rev.* 2018; 118: 1917-1950. DOI: 10.1021/acs.chemrev.7b00534
 61. Skotland T, Sandvig K, Llorente A. Lipids in exosomes: Current knowledge and the way forward. *Prog Lipid Res.* 2017; 66: 30–41. DOI: 10.1016/j.plipres.2017.03.001
 62. Škufca D, Kovačič A, Griessler Bulc T, Heath E. Determination of 18 bisphenols in aqueous and biomass phase of high rate algal ponds: Development, validation and application. *Chemosphere.* 2021a; 271: 129786. DOI: 10.1016/j.chemosphere.2021.129786
 63. Škufca D, Kovačič A, Prosenc F, et al. Phycoremediation of municipal wastewater: Removal of nutrients and contaminants of emerging concern. *Science of the total environment.* 2021b; 782: 146949. <https://doi.org/10.1016/j.scitotenv.2021.146949>
 64. Škufca, D.; Božič, D.; Hočevar, M.; Jeran, M.; Bedina Zavec, A.; Kisovec, M.; Podobnik, M.; Matos, T.; Tomazin, R.; Igljč, A.; Griessler Bulc, T.; Heath, E.; Kralj-Igljč, V. Interaction between Microalgae *P. tricornutum* and Bacteria *Thalassospira* sp. for Removal of Bisphenols from Conditioned Media. *Int. J. Mol. Sci.* 2022a; 23, 8447. <https://doi.org/10.3390/ijms23158447>
 65. Škufca D, Prosenc F, Griessler Bulc T, Heath E. Removal and fate of 18 bisphenols in lab-scale algal bioreactors. *Science of the total environment.* 2022b; 804: 149878. DOI: 10.1016/j.scitotenv.2021.149878
 66. Smith R, Vaughan C. The decomposition of acidic and neutral cannabinoids in organic solvents. *J Pharm Pharmacol.* 1977; 29: 286-290. DOI: 10.1111/j.2042-7158.1977.tb11313.x
 67. Théry C, Amigorena S, Raposo G, Clayton A. Isolation and characterization of exosomes from cell culture supernatants and biological fluids. *Curr Protoc Cell Biol.* 2006; 3, 3.22. DOI: 10.1002/0471143030.cb0322s30
 68. Théry C, Witwer KW, Aikawa E, et al. Minimal information for studies of extracellular vesicles 2018 (MISEV2018): a position statement of the International Society for Extracellular Vesicles and update of the MISEV2014 guideline. *J Extracell Ves.* 2018; 7: 1535750. DOI: 10.1080/20013078.2018.1535750
 69. Tian Y, Gong M, Hu Y, et al. Quality and efficiency assessment of six extracellular vesicle isolation methods by nano-flow cytometry. *J Extracell Ves.* 2019; 9: 1697028. DOI: 10.1080/20013078.2019.1697028
 70. Turchinovich A, Drapkina O, Tonevitsky A. Transcriptome of Extracellular Vesicles: State-of-the-Art. *Front Immunol.* 2019; 10: 202. <https://doi.org/10.3389/fimmu.2019.00202>
 71. Turkki V, Alppila E, Ylä-Herttua S, Lesch, H.P. Experimental Evaluation of an Interferometric Light Microscopy Particle Counter for Titering and Characterization of Virus Preparations. *Viruses.* 2021; 13: 939. DOI: 10.3390/v13050939
 72. van der Pol L, Stork M, van der Ley P. Outer membrane vesicles as platform vaccine technology. *Biotechnol J.* 2015; 10: 1689-1706. DOI: 10.1002/biot.201400395
 73. Wagner A, Vorauer-Uhl K. Liposome Technology for Industrial Purposes. *Drug Deliv.* 2011; 2011: 591325. <https://doi.org/10.1155/2011/591325>
 74. Yates AG, Pink RC, Erdbrügger U, Siljander RM, et al. In sickness and in health: The functional role of extracellular vesicles in physiology and pathology in vivo: Part I: Health and Normal Physiology: Part I: Health and Normal Physiology. *J Extracellular Ves.* 2022; 11:e12151. DOI: 10.1002/jev2.12151
 75. Zuardi AW, Crippa JA, Hallak JEC, et al. A critical review of the antipsychotic effects of cannabidiol: 30 years of a translational investigation. *Curr Pharm Des.* 2012; 18: 5131-5140. DOI: 10.2174/138161212802884681





Invited lecture/Scientific contribution

Dielectric Study of Induced Phase Transitions in Lyotropic Liquid Crystals

Starzonek Szymon^{1*}, Rzoska Sylwester J.², Iglič Aleš¹

- ¹ Laboratory of Physics, Faculty of Electrical Engineering, University of Ljubljana, Ljubljana, Slovenia
- ² Institute of High Pressure Physics of the Polish Academy of Sciences, Warsaw, Poland
- * Correspondence: Szymon Starzonek; szymon.starzonek@fe.uni-lj.si

Citation: Starzonek S, Rzoska SJ, Iglič A. Dielectric study of induced phase transitions in lyotropic liquid crystals. *Proceedings of Socratic Lectures*. 2023, 8; 88-96.
<https://doi.org/10.55295/PSL.2023.II13>

Publisher's Note: UL ZF stays neutral with regard to jurisdictional claims in published maps and institutional affiliations.

Abstract

Lyotropic liquid crystals are multicomponent systems of fundamental importance. They can also construct model structures for biological systems. The richness of their phases allows for the theoretical prediction of behaviour and the planning of model experiments enabling an approximation of the description of a living cell.

In this work, we present experimental results for lyotropic liquid-crystalline lamellar phases, which may be used as a physical model of phospholipid bilayer. Dielectric measurements were performed under temperature and high-pressure conditions. Complex dynamics, dielectric response, static properties as well as electric conductivity were considered and analysed on the basis of the critical phenomena theory. Other dielectric/electrostatic properties were also calculated and compared to evidence for biological systems.

Keywords: Lyotropic liquid crystals, Dielectric constant, Phase transition, Critical phenomena, Electric properties



Copyright: © 2023 by the authors. Submitted for possible open access publication under the terms and conditions of the Creative Commons Attribution (CC BY) license (<https://creativecommons.org/licenses/by/4.0/>).

1. Introduction

Lyotropic liquid crystals are mixtures of amphiphilic molecules and solvents. The properties of this mesophase change with temperature, pressure and the relative concentration of the individual components of the solution. An important property of lyotropic liquid crystals is the self-assembly of amphiphilic molecules into supramolecular structures, which are the basic components of the mesophase (de Gennes and Prost, 1993; Figueiredo and Salinas, 2005). The physicochemical properties of these liquid crystals are closely related to many fields of science, especially biological and engineering sciences used in technical and technological research (Sasi et al., 2016) of cosmetics, detergents, crude oil, biomass and finally food (Mezzenga et al., 2005; Sagalowicz et al., 2016).

Lyotropic systems can also be considered as supramolecular colloids. This is especially true for the first family of lyotropic liquid crystals. Individual micelles are particles dispersed in a polar solvent. The methods of colloid physics can be used in the analysis of these systems.

Amphiphilic molecules, which form organisationally higher structures, can arrange themselves in them in two ways. It depends on the concentration of the individual components of the mixture. If there is a higher concentration of water or another polar solvent in the system, the amphiphilic molecules align themselves with hydrophobic chains towards the centre of the structure formed. If, on the other hand, the situation is reversed, i.e. the concentration of the amphiphilic molecules is greater than the concentration of water, then they arrange themselves so that their hydrophobic parts protrude from the resulting structure.

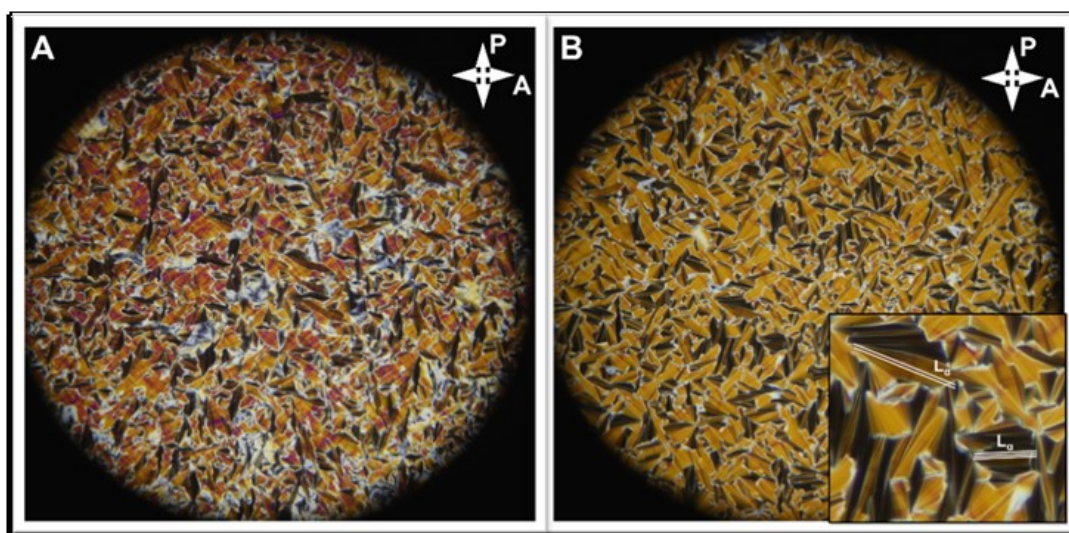

Figure 2. Frequency dependencies of the real parts of complex electric permittivity (A) and conductivity (B) for different pressures at $T = 310$ K. The static part of electric permittivity ϵ_s and conductivity σ_{DC} are marked.

Determining the order parameter in lyotropic liquid crystals was proposed in a model based on Landau-de Gennes' theory (Mukherjee and Bhattacharya, 2007). Experimental data showed that the lamellar phase L_α has the same symmetry as the smectic phase C of thermotropic liquid crystals. This situation is described by the traceless tensor Q_{ij} . Layers in the L_α phase have an order parameter expressed by $\psi(r) = \psi_0 \exp(-i\Psi)$. The complex modulus ψ_0 is defined as the amplitude of a condensed wave with phase Ψ .

The following form of the order parameter for the L_α lamellar phase was therefore proposed:

$$Q_{ij} = \frac{S}{2} (3n_i n_j - \delta_{ij}) \quad (1)$$

where n_i is different from $\nabla_i \Phi_j$, the value of S describes the ordering force of the nematic phase (Mukherjee and Bhattacharya, 2007; Mukherjee, 2013). However, this model needs to be further developed so that it can be applied to other more complex phases of lyotropic liquid crystals.

A much more convenient method of determining the order parameter is to use the modified Haller function. According to Meyer-Saupe's theory, it is based on the temperature of a continuous phase transition 1-2 K below the observed discontinuous transition. Experimental results and simulation data to date have shown that the use of this approach is consistent with theoretical predictions. The order parameter for the nematic and smectic A phases, and thus for the lamellar one, can be presented as follows:

$$\langle P_2 \rangle = \langle P_2 \rangle_{iso} + \left(1 - \frac{T_{meso}^*}{T}\right)^\beta \quad (2)$$

where $\langle P_2 \rangle$ is the second-order Legendre polynomial of rearranged permanent dipole moments $\vec{\mu}$, $\langle P_2 \rangle_{iso}$ is the order parameter of the isotropic liquid, T_{meso}^* denotes the hypothetical ideal phase transition located 1-2 K below isotropic-mesophase one and β is a critical exponent. According to the theory of universality, the critical exponent β is assumed to be in the range of 0.25-0.5 (Buscaglia, 2006).

2. Methods

Dielectric complex permittivity $\epsilon(\omega)^* = \epsilon(\omega)' + i\epsilon(\omega)''$ was measured using impedance Alpha-A analyser (Novocontrol, Montabaur, Germany) in a wide range of frequencies (1 Hz-10⁹ Hz) and temperatures (273-373 K). The sample was placed into a round, parallel steel capacitor with a diameter $2r = 20$ mm and a gap $d = 0.15$ mm. a Teflon[®] ring was used as a spacer. Temperature was stabilised using liquid nitrogen (N₂) in the QuatroCryo system (Novocontrol, Montabaur, Germany) with stability better than $\delta T = 0.02$ K.

The high-pressure measurements were performed in a chamber (Unipress Equipment, Warsaw, Poland). Samples were placed into a rectangle capacitor mounted in a Teflon[®] capsule. Temperature was stabilised by Julabo cooler/heater system (Julabo GmbH, Seelbach, Germany) with stability ca. $\delta T = 0.05$ K. Plexol[®] was used as a pressure medium. Dielectric spectra were measured using Alpha-A analyser (Novocontrol, Montabaur, Germany) ($f \in \langle 1 \text{ Hz}, 10^9 \text{ Hz} \rangle$). Lyotropic liquid crystalline (LLC) phase L_α , based on water and Dimodan[®], was prepared according to a protocol proposed by Mezzenga et al, (2005). Pictures of liquid-crystalline textures were taken using the PZO Studar[®] polarising microscope (PZO, Warsaw, Poland) with a self-built LC chamber and temperature stabilisation $\delta T = 0.5$ K.

3. Results

This part of the paper presents the results of temperature and pressure tests of phase transitions in the lamellar phase. **Figure 2** shows typical dielectric spectra over a wide frequency range. The data presented for the compression show the dependence of the real parts of the electric permittivity ϵ' (f) (**A**) and the conductivity σ' (f) (**B**). Due to the strong variability of the presented functions, the analysis of dielectric data of liquid crystals and biological systems should include static regions corresponding to the maximum polarisation of the sample. For the real permittivity part, it is the so-called dielectric constant ϵ_s , for the conductivity part it is DC-conductivity σ_{DC} (Rzoska et al., 2016; Starzonek et al., 2015). In the further course of the work, their temperature and pressure dependencies are analysed.

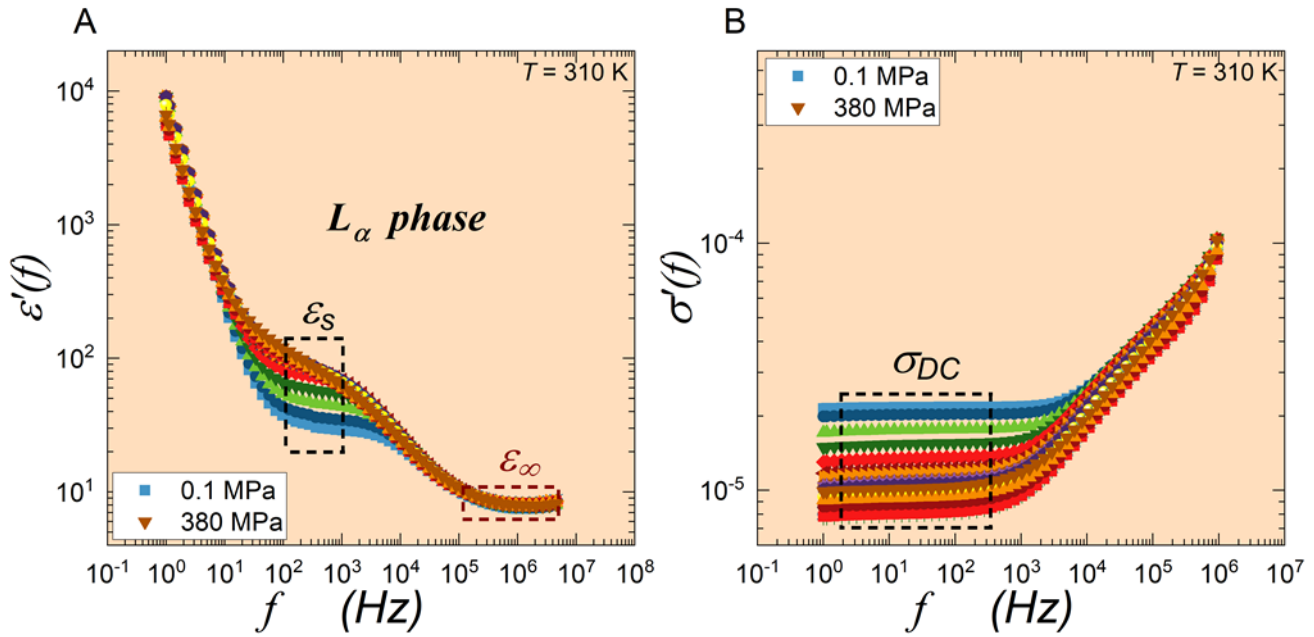

Figure 2. Frequency dependencies of the real parts of complex electric permittivity (A) and conductivity (B) for different pressures at $T=310$ K. The static part of electric permittivity ε_s and conductivity σ_{DC} are marked.

Figure 3 shows the dependence of the dielectric constant at the frequency $f = 100$ Hz over a wide temperature range. This representation enables the detection of phase transitions and the determination of their critical-like character. At the temperature $T = 322$ K (at atmospheric pressure), a sudden change in the dielectric constant is observed, which proves the existence of a discontinuous transition between the phases L_α and L_β . Near the phase transition temperature, a characteristic change in behaviour is observed, which is related to the antiparallel arrangement of the dipole moments. This phenomenon is associated with pretransitional fluctuations and occurs in many liquid crystal systems with a rod-like structure of the molecule. Based on the theory of critical phenomena, an exponential critical function with the critical exponent can be determined (Rzoska et al. 2016; Rzoska et al.,2020):

$$\varepsilon_s(T) = \varepsilon^* + A|T - T^*| + B|T - T^*|^\varphi \quad (3)$$

where (T^*, ε^*) describes a point of hypothetical ideal continuous phase transition, A, B are amplitudes and $\varphi = 1 - \alpha$ is the exponent related to heat capacity critical exponent. For the pressure path one may transform Equation (3) and obtain (Rzoska et al., 2016):

$$\varepsilon_s(P) = \varepsilon^* + A'|p^* - p| + B'|p^* - p|^\varphi \quad (4)$$

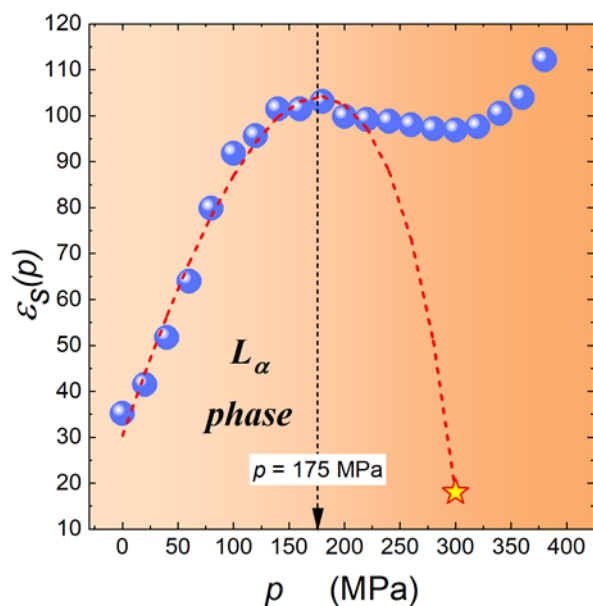

Figure 3. Temperature dependence of dielectric constant $\epsilon_s(T)$ at ambient pressure. Phase transition between two lamellar phases occurs at $T = 322$ K with strong pretransitional effects. Dashed lines present the fitting by the **Equation (3)**, which provides critical-like behaviour with the critical exponent $\alpha=0.5$. Stars denotes points for ideal continues phase transition.

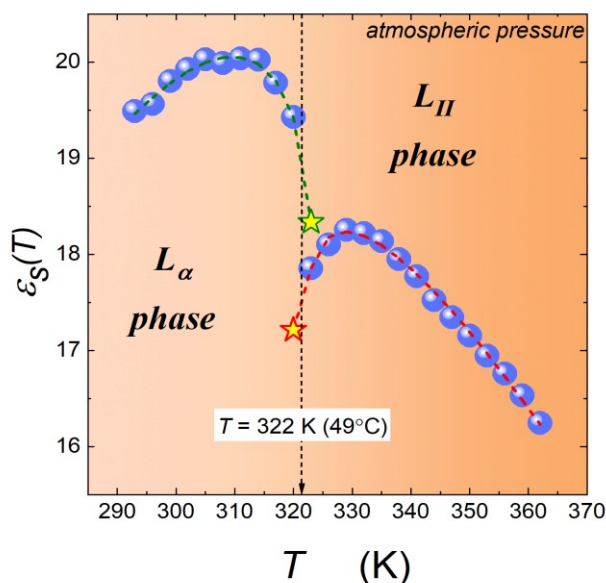

Figure 4. Pressure evolution of dielectric constant $\epsilon_s(p)$ at $T = 310$ K. Dashed line shows the fitting by the **Equation (4)**, which provides critical-like behaviour with the critical exponent $\alpha = 0.5$. The star denotes a point representing ideal continuous phase transition.

A similar analysis was carried out in an isothermal pressure experiment ($T = 310$ K) and the results are shown in **Figure 4**. A notable change in the behaviour of the dielectric constant occurs at a pressure of $p = 175$ MPa, which can be considered as a phase transition. Also, the fitting of **Equation (4)** leads to the demonstration of a critical-like behaviour with a strong pretransitional effect with exponent $\alpha = 0.5$.

The analysis of high-pressure data is difficult, so to confirm the existence of a weakly discontinuous phase transition, another physical quantity should be considered. In this case, it was decided to focus on the DC-conductivity, which is related to the mobility of ions in the system. **Figure 5** shows the pressure dependence of the DC-conductivity for the tested



system. At pressures $p = 175$ MPa and $p = 300$ MPa, two anomalies can be observed which can be interpreted as indications of a phase transition. The figure shows the differential analysis of the $\sigma_{DC}(p)$ relation and a clear discontinuity near the indicated points, which confirms the existence of a phase transitions.

Another good quantity to identify the phase transition and the behaviour near the critical point is the order parameter given by **Equations (1) and (2)**. Calculating order parameter $\langle P_2 \rangle$ one may expand **Equation (2)** in the Taylor series what gives (Zanoni, 2022; Starzonek, 2018):

$$\begin{aligned} \langle P_2 \rangle_T &\approx (1 - T^*x)^\beta \text{ for } x = \frac{1}{T} \\ \ln \langle P_2 \rangle_T &= \beta \ln(1 - T^*x) \approx -\beta T^*x = Ax + B \end{aligned} \quad (5)$$

This linearised form allows to easily fit the critical exponent β of obtained data from a slope $\beta = \left| \frac{T^*}{A} \right|$.

For the pressure experiments it is possible to propose an analogue formula for p^* as follows

$$\langle P_2 \rangle_p \approx \left(1 - \frac{p}{p^*}\right)^{\beta'} \rightarrow \ln \langle P_2 \rangle_p = \beta' \ln \left(1 - \frac{p}{p^*}\right) \approx -\frac{\beta'}{p^*}p = Cx + D \quad (6)$$

where p^* denotes continuous phase transition pressure and $\beta' = |p^*C|$.

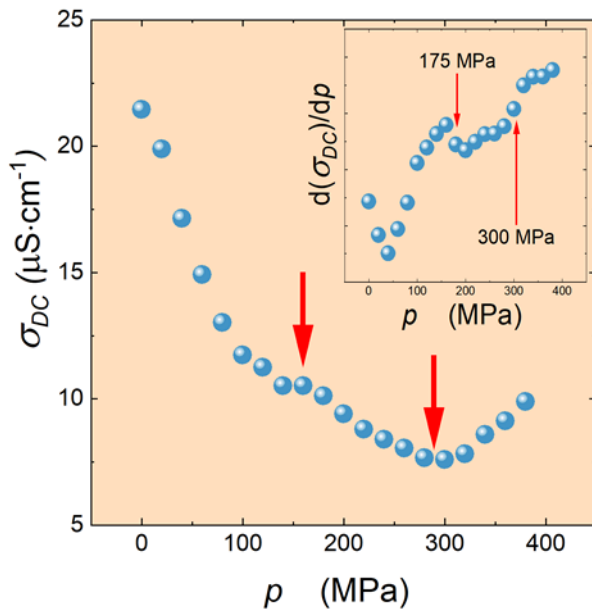

Figure 5. Pressure dependence of DC-conductivity $\sigma_{DC}(p)$ at $T = 310$ K. Arrows present anomaly behaviour and potential phase transitions. The inset shows derivative-based analysis of obtained data with strong discontinuities at marked pressures.

Figure 6 shows the temperature (A) and pressure (B) dependence of the order parameters near the phase transition point. The calculations were carried out based on **Equation (2)** with the assumed critical exponent $\beta = 0.25$. A typical change during the function describing the order parameter near the temperature/pressure of the phase transition makes it possible to determine it. It is worth noting that in the case of the temperature dependence, both the L_α and L_{II} phases have a similar degree of order, while in the case of the pressure data at atmospheric pressure $p = 0.1$ MPa, the order parameter is identical to its temperature equivalent, $\langle P_2 \rangle_p(0.1 \text{ MPa}) \equiv \langle P_2 \rangle_T(310 \text{ K})$.

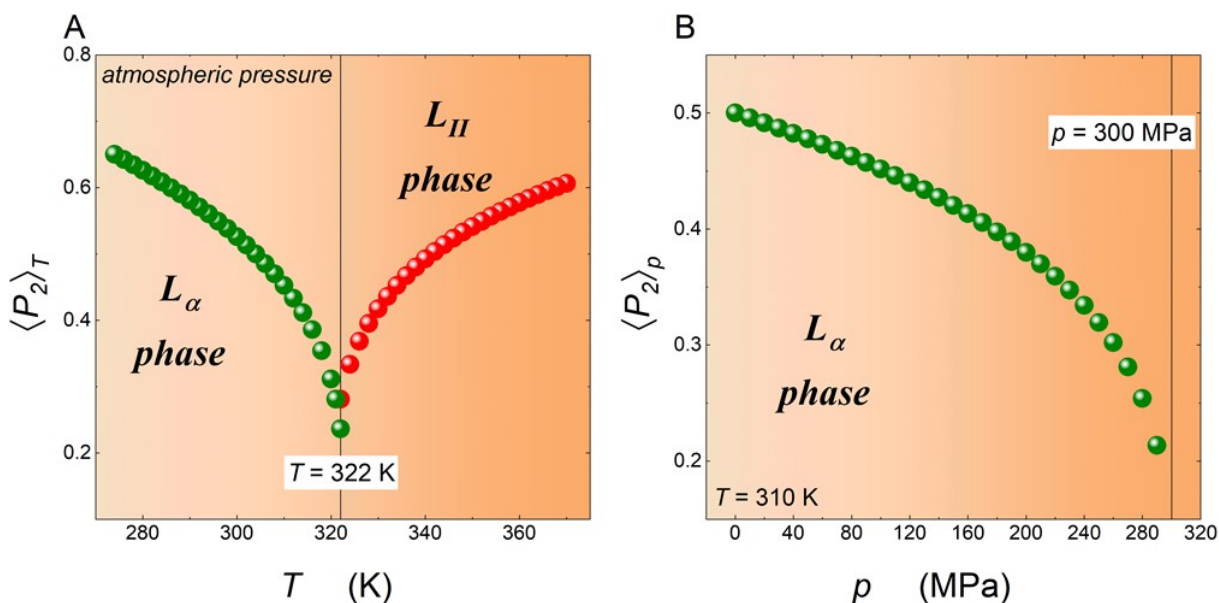

Figure 6. Order parameters for temperature (A) and pressure (B) experiments calculated from **Equation (2)** with a critical exponent $\beta = 0.25$.

4. Discussion

The results presented in this paper are undoubtedly among the first obtained with dielectric spectroscopy methods on this type of system. It is worth mentioning that the analysis of phase transitions of lyotropic liquid crystals plays a significant role in many fields of science, such as biology, food science and materials science. Due to the analysis of the behaviour near the phase transition of a given system, many physical and physicochemical properties can be predicted.

Previous studies of similar systems have focused on computer simulations or theoretical considerations, and few presented model liquid crystal systems with potential utility for the food industry (Sagalowicz et al., 2016). The focus on the lamellar phase is intended to bring the theoretical description closer to the results obtained by experimental methods and to those derived from computer simulations (Mukherjee et al., 2007). It is worth mentioning that the analysis of phase transitions between the L_α phase and the L_{II} phase has not been the basis of research so far. These two phases differ from each other only in details, which makes the transition between them appear to be weakly discontinuous or continuous. Due to the temperature analysis of the dielectric constant, shown in **Figure 3**, the existence of a strong anomaly before the transition between the two lamellar phases has been demonstrated. It can therefore be assumed that this transition is not a subtle structural change, but a strong discontinuous transition with a critical character.

Similar conclusions can be drawn for high pressure data. In this type of experiment, it is extremely important to maintain isothermal and isobaric conditions at each measurement point. Therefore, there are few experimental results for liquid crystals under high pressure conditions, especially for lyotropic materials. The phase transition observed and shown in **Figure 4** is a weakly discontinuous transition. Therefore, only the use of additional extremely sensitive methods, which include differential analysis, leads to the detection of the phase transition. However, the main problem with a pressure experiment is the identification of the individual phases. This is due to the lack of a phase diagram, i.e. the nature of the materials as a function of pressure. While in the case of the temperature experiment, the identification of the individual phases is not a problem and corresponds to what was previously postulated in the literature, the compression of the system can lead to the complete destruction of the lamellar structure and the formation of, for example, a micellar structure or even inverted structures. Undoubtedly, such experiments require further work and analysis. The tested system consists of an amphiphilic agent and water, which makes the investigation of DC-conductivity reasonable. In the temperature tests, no significant changes in DC-conductivity were observed, clearly indicating a phase



transition near the characteristic temperature (Starzonek et al., 2015; Starzonek, 2018; Rzoska et al., 2016; Rzoska et al., 2020). In pressure tests, however, the DC-conductivity becomes a key parameter for identifying phase transitions. With increasing pressure, the density of the system under investigation increases, and in systems consisting of amphiphilic molecules and water, we are only dealing with a rearrangement of the molecular positions. Thus, observing the released ions, which are from the water, allows us to assess how the molecules arrange themselves in individual lyotropic phases. It would be possible to transfer the phase diagram in the temperature scale to the pressure scale and conclude that above the phase transition pressure the lamellar structure is destroyed. However, it is not possible to say unequivocally whether this is not accompanied by a phase change with the release of bound water.

Due to the analysis of the order parameters in liquid crystalline phases, it is possible to determine what kind of transition we are dealing with as well as to calculate other physical parameters. One of the most used functions for the order parameter is the so-called Haller function, which is based on the Meyer-Saupe theory (Zanonni, 2022; Starzonek, 2018). This function assumes, based on the classical isotropic liquid-nematic phase transition, that the critical point for this type of transition is a discontinuous transition. However, previous studies have shown that in the presence of a strong anomaly before the transition, the critical point, which is the site of a continuous phase transition, is much lower than the temperature of the observed phase transition. Therefore, in this work it was decided to use the modified Haller function based on the Landau-de Gennes theory of phase transitions of liquid crystals, thanks to which the exponent contained in **Equation (2)** can be considered as the critical exponent. Numerous theoretical experiments and computer simulations have shown that the value of this exponent is about 0.25 for both the nematic and smectic phases. If we assume that the lamellar phase can be approximated by the smectic phase, then the critical exponent beta equal to $\beta = 0.25$ can be easily assumed for theoretical considerations of professional transitions (Buscaglia et al., 2006; Zanonni, 2022).

Summing up, the presented results are undoubtedly a valuable contribution to the development of soft matter physics, as well as biology, food science and materials science. Thanks to the approach presented by the theory of critical phenomena, it is possible to fully analyse the phase transitions between the L_α and L_{II} phases. The existence of strong pre-transition effects, characteristic of both the nematic and smectic phases, allows the use of existing theoretical tools to analyse the obtained results. Undoubtedly, the calculated critical exponents $\alpha = 0.5$ and $\beta = 0.25$ allow to assign the tested system to the same universality class in which we can find other liquid crystal structures. Further analysis of the ordering parameter based on computer simulations and in-depth theoretical description will allow to link the symmetry of the system with molecular dynamics. This type of research is a valuable contribution to the creation of a modern model of the biological membrane, considering its interactions with nanoparticles or microorganisms (Raval et al., 2021).

Funding: S.S. and A.I. were supported by the Slovenian Research Agency (ARRS) through the grants numbers P2-0232, J2-4447, J3-3066, J3-2533 and J3-3074.

Conflicts of Interest: The authors declare no conflict of interest.

References

1. Buscaglia M, Bellini T, Chiccoli C, Mantegazza F, et al. Memory effects in nematics with quenched disorder. *Phys Rev E Stat Nonlin Soft Matter Phys.* 2006; 74: 011706. DOI: 10.1103/PhysRevE.74.011706
2. de Gennes PG, Prost J. *The Physics of Liquid Crystals.* Oxford university press. 1993.
3. Figueiredo NAM, Salinas SRA. *The physics of lyotropic liquid crystals: phase transitions and structural properties.* Vol. 62. OUP Oxford. 2005. DOI: 10.1021/la046964b
4. Mezzenga R, Meyer C, Servais C, Romoscanu AI, et al. Shear rheology of lyotropic liquid crystals: a case study. *Langmuir.* 2005; 21: 3322-3333. DOI: 10.1021/la046964b



5. Mukherjee PK, Bhattacharya J. Phenomenological theory of the nematic to lamellar phase transition in lyotropic liquid crystals. *J Chem Phys.* 2007; 126: 01B605. DOI: 10.1063/1.2426343
6. Mukherjee PK. Isotropic micellar to lamellar phase transition in lyotropic liquid crystals. *RSC Adv.* 2013; 3: 12981-12984.
7. Raval J, Gongadze E, Benčina M, Junkar I, et al. Mechanical and electrical interaction of biological membranes with nanoparticles and nanostructured surfaces. *Membranes (Basel).* 2021; 11: 533. DOI: 10.3390/membranes11070533
8. Rzoska SJ, Starzonek S, Drozd-Rzoska A. Pretransitional behavior and dynamics in liquid crystal-based nanocolloids. *Advances in Colloid Science.* Editors: Mohammed Muzibur Rahman, Abdullah Mohamed Asiri. 2016; pp. 265-274. DOI: 10.5772/64910
9. Rzoska SJ, Starzonek S, Łoś J, Drozd-Rzoska A, Kralj S. Dynamics and pretransitional effects in C60 fullerene nanoparticles and liquid crystalline dodecylcyanobiphenyl (12CB) hybrid system. *Nanomaterials (Basel).* 2020; 10: 2343. DOI: 10.3390/nano10122343
10. Sagalowicz L, Moccand C, Davidek T, Ghanbari R, et al. Lipid self-assembled structures for reactivity control in food. *Philos Trans A Math Phys Eng Sci.* 2016; 374: 20150136. DOI: 10.1098/rsta.2015.0136
11. Sasi R, Sarojam S., Devaki SJ. High performing biobased ionic liquid crystal electrolytes for supercapacitors. *ACS Sustainable Chem. Eng.* 2016; 6: 3535-3543. DOI: 10.1021/acssuschemeng.6b00585
12. Starzonek S, Rutkowska M, Rzoska SJ, Drozd-Rzoska A, et al. Dielectric spectroscopy of pressurized *Saccharomyces cerevisiae*. *Food Biophys.* 2015; 10: 229-234. DOI: 10.1007/s11483-014-9367-y
13. Starzonek S. Study of phase transitions in nanoparticles doped liquid crystals. Master's degree thesis. Katowice. 2018
14. Zannoni C. *Liquid Crystals and Their Computer Simulations.* Cambridge University Press. 2022. DOI: 10.1017/9781108539630



*Invited lecture/Review*

Pathogen-Plant Interactions in Plant Membrane Perforation

Prešern Andreja^{1,*}^{1.} National Institute of Chemistry, Slovenia^{*} Correspondence: Andreja Prešern; andreja.habic@ki.si**Abstract:**

Plants are targets of many pathogens that produce a lot of different effectors to damage plant cells during infection. For plant survival, it is, therefore, crucial to possess an efficient immune system, which in contrast to mammalian immunity, consists only of innate immunity. Traditionally, plant immunity is divided into two branches, i.e. pattern-triggered (PTI) and effector-triggered immunity (ETI), but the accumulating knowledge has shown that the division cannot be strictly maintained. ETI coevolves with pathogen effector

molecules, which can function in many different ways to escape plant immunity and damage plant cells. Among their targets is the plant plasma membrane, which represents an important cell barrier. There are several different tactics to bypass this barrier, e.g. membrane perforation by proteins or peptides, which is an important and ubiquitously found mechanism of toxicity as well as self-defense in all kingdoms of life. It can be used to get specific molecules from cells, for signaling, or even to deliver effector molecules into the cytoplasm. The exact knowledge on plant membrane perforation, however, is lacking, and the hidden details still await to be unveiled.

Keywords: Plant immune System; Pathogen-Plant Interactions; Plant Membrane Perforation

Citation: Prešern A. Pathogen-Plant interactions in plant membrane perforation. *Proceedings of Socratic Lectures*. 2023, 8; 98-108.
<https://doi.org/10.55295/PSL.2023.II14>

Publisher's Note: UL ZF stays neutral with regard to jurisdictional claims in published maps and institutional affiliations.



Copyright: © 2023 by the authors. Submitted for possible open access publication under the terms and conditions of the Creative Commons Attribution (CC BY) license (<https://creativecommons.org/licenses/by/4.0/>).



1. Introduction

Plants are targets of all pathogen classes, including viruses, bacteria, oomycetes, fungi, nematodes, and feeding insects. During infection and colonization of specific plant species, pathogens produce different effectors, i.e. proteins and small molecules that can facilitate pathogen entry into the host interior, suppress plant immune system, or alter host physiology for their benefit. Effectors can function extra- or intracellularly and target different parts of plant cells. In this review, we will focus on the pathogen-plant interactions that lead to the perforation of the plant plasma membrane. To see and understand a broader picture of the interplay between the pathogen and host-derived molecules, we will begin with a short overview of the plant immune system.

2. Plant Immune System

Besides physical barriers, an efficient immune system is crucial for the survival of any long-lived organism. Jawed vertebrates possess probably the most sophisticated immunity, which consists of a relatively nonspecific innate and a highly specific adaptive branch. Plants have no circulatory system and mobile immune cells to use such circulatory receptors. Therefore, they use much simpler mechanisms, that can be executed by every cell. Nonetheless, they can still respond with high specificity and restricted self-reactivity, and often generate a lifelong 'memory' of the encountered pathogens (Spoel et al., 2012).

All plant immune responses rely solely on innate immunity, which consists of two parts: pattern-triggered immunity (PTI) and effector-triggered immunity (ETI). Each of them uses a variety of receptors that require different early signaling components and activate specific downstream mechanisms. Many final responses of both pathways are nonetheless similar, with a largely overlapping set of genes but with distinct amplitudes and dynamics (Zhang et al., 2010; Yuan et al., 2021).

2.1. PTI

The general components of the plant immune system that pathogens must encounter are pattern recognition receptors (PRRs), which reside in the plasma membrane. They recognize pathogen-associated molecular patterns (PAMPs), which are pathogen-derived molecules, e.g. lipooligosaccharides of gram-negative bacteria, bacterial flagellin, glucans and glycoproteins from oomycetes, or chitin from the fungus cell wall (Zhang et al., 2010).

All currently known PRRs are either receptor-like kinases (RLKs) or receptor-like proteins (RLPs). Both classes conduct signals from the outside to the inside of a cell and are composed of three parts, the first two having identical functions: an extracellular portion of the protein to recognize PAMPs and a transmembrane part to connect the outside with the inside of a cell. The third, intracellular part of PRRs triggers the response with either a kinase domain (RLKs) or through the interaction of a short intracellular tail (RLPs) with adaptor protein bearing a kinase activity (Boutrot et al., 2017; Yuan et al., 2021).

Upon ligand recognition, structural changes of PRRs induce the recruitment of co-receptors to form a receptor complex, in which trans-phosphorylation occurs. Such activated receptor complex further phosphorylates and therefore activates receptor-like cytoplasmic kinases (RLCKs), which activate many downstream proteins. This leads to diverse physiological outputs, e.g. ROS production, Ca²⁺ influx, MAPK activation, production of defense hormones, stomatal closure, and cell wall reinforcement. The responses induce both local as well as systemic immunity (Boutrot et al., 2017; Liang et al., 2018; Yuan et al., 2021).

2.1.1. Resistance to PTI

PAMPs are molecules that are crucial for the fitness of pathogens. Therefore, they are conserved within a class of microbes and are less likely prone to mutations, which makes them a good target for PTI (Medzhitov et al., 1997). Pathogens, however, adapted to overcome PTI with the production of a wide variety of effector molecules, that interfere with PTI and are recognized by ETI.



2.2. ETI

Unlike PAMPs, effectors are species, race, or strain specific. Since not only pathogens but also plants are constantly coevolving, they have responded to these effectors with the development of resistance (R) proteins, which act as the sensing component of ETI (Thomma et al., 2011).

Most R-genes identified to date encode nucleotide-binding domain leucine-rich repeat (NLR) immune receptors (Sánchez-Martín et al., 2021). NLRs can be classified into two functional groups: sensor NLRs that recognize the effector and helper NLRs required by sensor NLRs to trigger ETI (Sun et al., 2020; Cox, 2021). It is important to note that R proteins can detect either the presence of or the activity of their target effector (Jonathan D.G. Jones et al., 2006). Because of selection pressure, pathogen effectors are constantly evolving to escape the R protein recognition, and new effectors are occurring to suppress ETI. But not just effectors, plant R proteins are also continuously coevolving to be able to effectively trigger and execute ETI (Thomma et al., 2011).

It has been postulated for a long time that ETI response is similar to PTI but “accelerated and amplified”. Besides ROS production, Ca²⁺ influx, MAPK activation and transcriptional reprogramming, it results in programmed cell death at the infection site, referred to as the hypersensitive response (HR). First, a zig-zag model of plant immune system was proposed (**Figure 1A**) (Jones and Dangl, 2006), but recent experimental evidence calls for its refinement (**Figure 1B**). It was shown that PTI and ETI are functionally linked – many signaling components were found to participate in both of them (Yuan et al., 2021).

2.3. The Interplay Between PTI and ETI

With the accumulating knowledge, it has become evident, that dividing pathogen-derived molecules into PAMPs and effectors, and separating PRRs and R proteins cannot strictly be maintained (Thomma et al., 2011). Certain effectors are so widely spread, that they should be characterized as PAMPs. Such an example are necrosis- and ethylene-inducing peptide 1 (Nep1)-like proteins (NLPs) that are conserved among bacteria, fungi, and oomycetes (Gijzen et al., 2006). On the other hand, some PAMPs have a rather narrow distribution or, despite being widespread, they are not widely recognized among plants. These examples implicate that there is no strict line, but rather a continuum between PTI and ETI (Thomma et al., 2011).

3. Pathogen-Plant Interactions in Plant Membrane Perforation

The plasma membrane represents an important cell barrier, that separates the interior from the outside world and enables the cell to maintain its homeostasis. As pathogens depend on host cell metabolism or intracellular components (e.g. nutrients), they developed different solutions to efficiently bypass this barrier. This can be either through a) endocytosis of effectors, followed by their escape from intracellular vesicles (described in (Kale et al., 2011), b) direct intracellular delivery of effectors through the membrane, or c) with the help of pore-forming effectors, which are able to perforate their target membrane. Besides pathogen-driven permeabilization of the plant membrane, the regulation of its permeability as a self-defense mechanism is also discussed in this chapter.

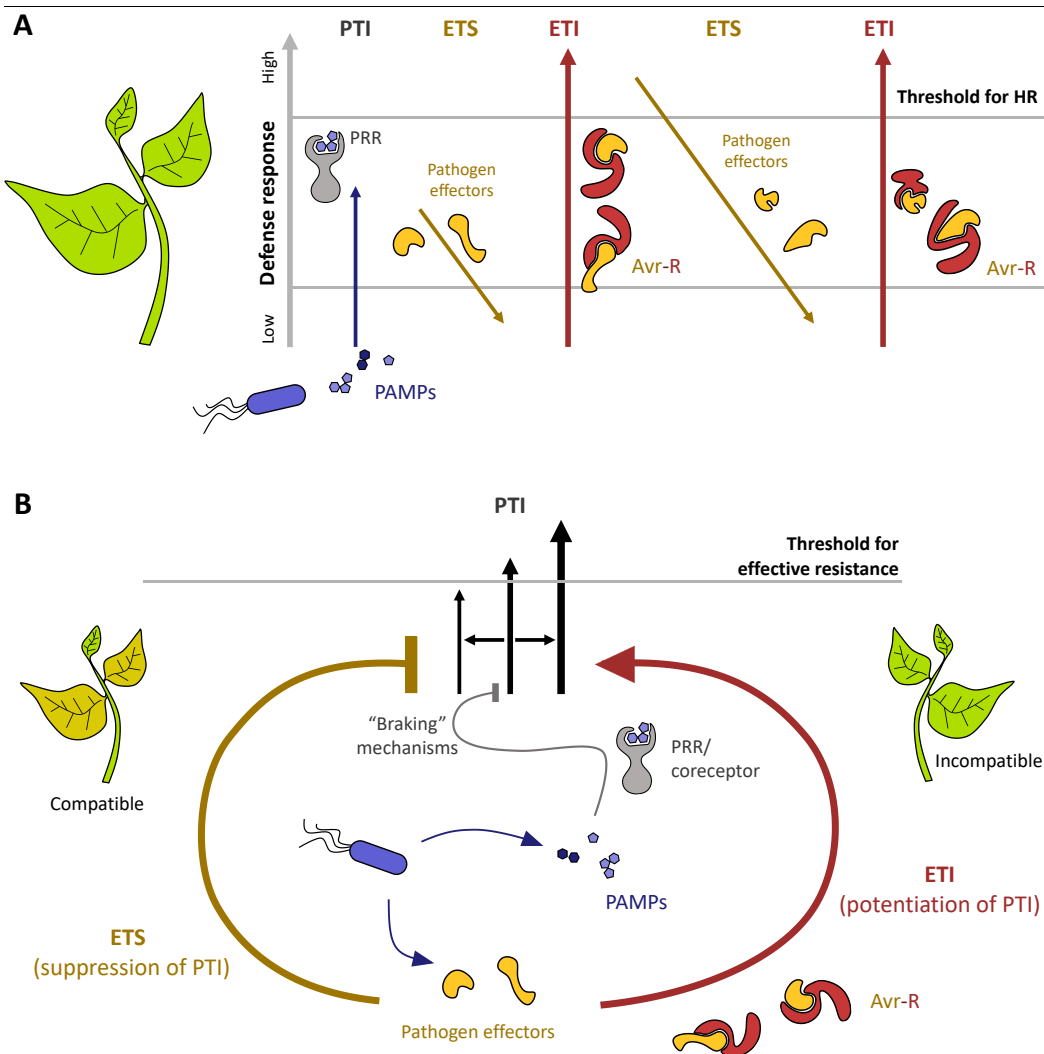

Figure 1: (A) A zig-zag model of plant immune system. First, PAMPs are recognized by PRRs, triggering PTI. Pathogen effectors can interfere with PTI, which results in effector-triggered susceptibility (ETS). Such effectors can be recognized by R proteins that trigger ETI, causing disease resistance and, usually, an HR. Effectors recognized by R proteins are called avirulence factors (Avr). Natural selection leads pathogens to further avoid ETI, evolving new effectors. The same mechanism is present in plants, evolving new R proteins. **(B) An updated model of plant immunity.** PTI acts as the primary defense mechanism. Its components are under negative control by the endogenous »braking« mechanisms of plants to prevent over activation and also by pathogen effectors (grey and yellow blunt arrows). The effectors are recognized by R proteins, which trigger ETI. This leads to upregulation of PTI components, causing potentiation and restoration of PTI (red arrow). »PTI + ETS« is usually associated with compatible interactions (left), while »PTI + ETI« with the incompatible ones (right).

3.1. Pore-Forming Proteins

Membrane perforation by pore-forming proteins (PFPs) is an important and ubiquitously found mechanism in all kingdoms of life. PFPs can serve as toxins or as a part of the immune system. They are produced as soluble monomers, which, upon the target membrane recognition, change their conformation, and form multimeric, active transmembrane pores (reviewed in (Dal Peraro et al., 2016; Mesa-Galloso et al., 2021)) (**Figure 2**). There is a large amount of knowledge about PFPs, however, the information about their roles in plants was missing for a long time. Not long ago, it was shown that effector proteins NLPs can specifically bind to plant plasma membrane and are capable of its perforation (Lenarčič et al., 2017). These findings opened a completely new area in plant research, with many important milestones achieved in the past few years.

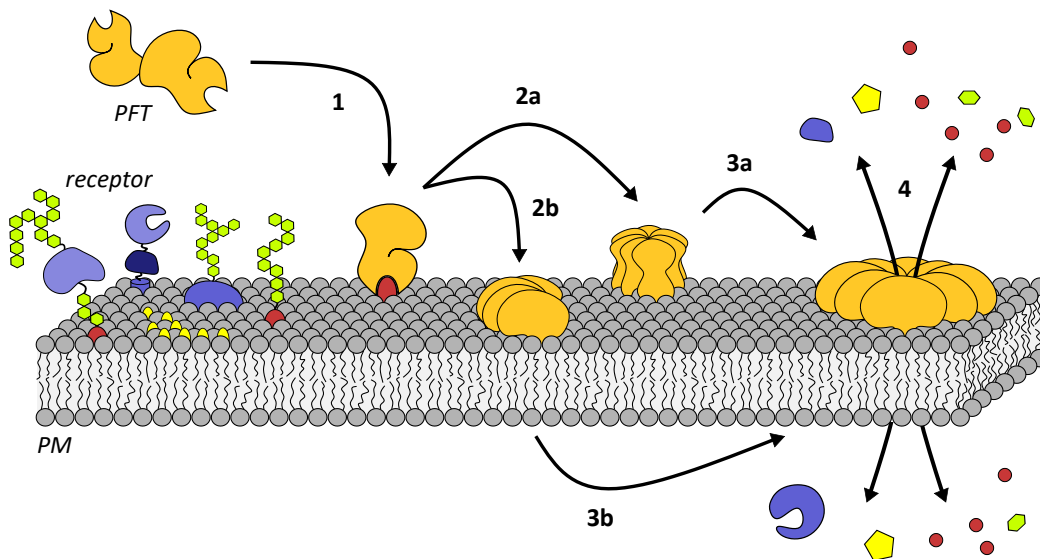

Figure 2: Generalized mechanism of pore formation by PFTs. Soluble PFTs recognize their membrane receptor, which can be either (glyco)protein or (gylco)lipid (1). Oligomerization occurs either through a pre-pore complex on a membrane surface (2a), which eventually undergoes conformational rearrangement to form a pore (3a), or the membrane insertion is concomitant with a sequential oligomerization, leading to partial (2b) or complete pore formation (3b). This results in increased membrane permeability (4).

3.1.1. *Nep1-like Proteins*

NLPs are widely spread apoplastic effectors produced by several plant pathogens from bacteria, fungi, and oomycetes, including *Phytophthora infestans*, which caused the Great Irish Famine (Oome et al., 2014 a). They trigger leaf necrosis and immunity-associated responses in several plants (Jennings et al., 2000; Veit et al., 2001; Fellbrich et al., 2002; Bae et al., 2006; Garcia et al., 2007; Feng et al., 2014; Xiang et al., 2022). For the necrotic activity, an N-terminal secretion signal peptide and a conserved heptapeptide motif are needed (Oome et al., 2014 a; Seidl et al., 2019), while PTI is triggered through a highly conserved region of 20 or 24 amino acids (Böhm et al., 2014; Oome et al., 2014 b). According to the number of the cysteine residues they contain, they can be divided into three classes: type I, which is the most abundant and contains two cysteines, type II, which contains four cysteines, and type III, which contains six cysteines. They might be toxic or non-toxic (Seidl et al., 2019), and structurally resemble cytolytic PFTs actinoporins (Küfner et al., 2009; Ottmann et al., 2009). While actinoporins target glycolipid sphingomyelin (Birck et al., 2004; Kristan et al., 2009), NLPs were found to bind the sugar headgroup of plant-specific sphingolipids glycosylinositol phosphorylceramides (GIPCs) (Lenarčič et al., 2017) (**Figure 3A**). Plant sterols and low salt concentration were also shown to promote the membrane binding of NLPs (Pirc et al., 2022).

Distinguishing Between the Monocot and Dicot Membrane Components?

It was soon noticed that in general, NLPs affect dicot, but not monocot plants, which can be explained by the difference in their GIPC-composition: dicot plants contain mostly GIPCs with two terminal hexoses, while in monocots the predominant species are GIPCs with three terminal hexoses (Gronnier et al., 2016). Although NLPs can bind both kinds of GIPCs, a membrane disrupting activity was restricted to plasma membrane vesicles from dicot plants. One possible explanation is that the longer sugar headgroup in monocots creates a distance too large for the bound NLP to reach the membrane (Lenarčič et al., 2017) (**Figure 3B**). However, cytolytic NLPs are produced by pathogens of monocots as well. Recently, their cytotoxic activity on monocots was shown Steentjes et al., 2022), but the mechanism of membrane binding and pore formation was not assessed.

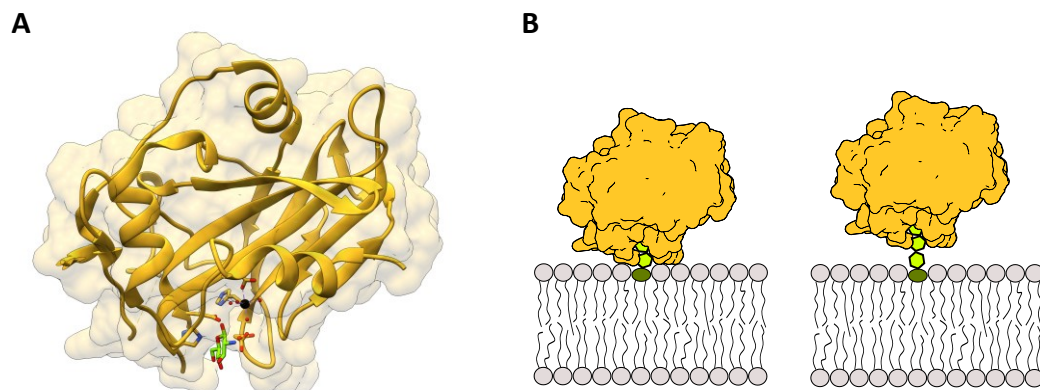

Figure 3: (A) NLP_{Pya} crystal structure (PDB 5NNW) with bound glucosamine. Glucosamine is one of the possible terminal hexoses of GIPCs. NLP_{Pya} is shown in yellow, glucosamine in green, and Mg²⁺ in black. (B) A model of NLP binding to GIPC with two (left) or three (right) terminal hexoses. In the first case, NLP can interact with the membrane surface, while in the latter it cannot.

Mechanism of Pore Formation

According to the current knowledge, a unique mechanism of pore-formation by NLP_{Pya}, the cytotoxic model NLP, was recently proposed (Figure 4). As a soluble monomer, NLP_{Pya} recognizes its target, i.e. the polar headgroup of GIPCs through electrostatic interactions, and its interaction is strengthened in the presence of sterols. One molecule of NLP binds multiple GIPCs, which leads to its aggregation and small pore formation. The mechanism is unique among currently known PFPs due to the shallow membrane binding of NLP_{Pya}, and the transient nature of the pores (Pirc et al., 2022).

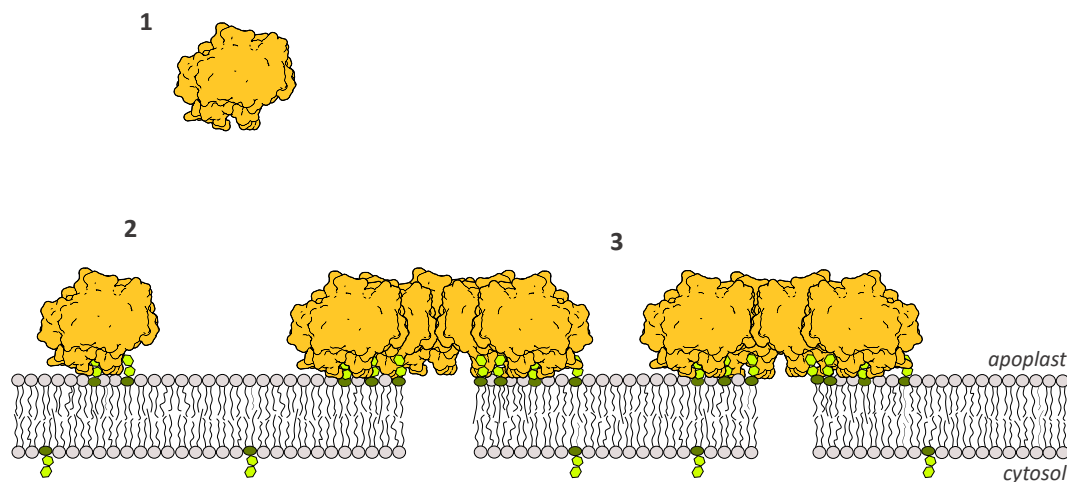

Figure 4: Mechanism of pore formation by NLPs. Soluble NLP (1) binds multiple membrane receptors, i.e. GIPCs (2). This leads to the aggregation of NLP molecules and the formation of small transient pores (3).

Facilitated Oligomerization

Recently, the analysis of *A. thaliana* accessions with different sensitivities to NLP toxicity showed that there are also other factors contributing to NLP-pore formation. A gene encoding a leucine-rich repeat (LRR)-only protein NTCD4 (NLP-triggered cell death on chromosome 4) promotes the toxicity of NLP if secreted into the apoplast. Although its mode of action is not yet well understood, NTCD4 was shown to physically interact with NLP, facilitating its oligomerization (Chen et al., 2021).

3.2. Pore-Forming Peptides

Besides PFPs, pore formation can be also caused by peptides. Usually, peptides are used as host defense to damage pathogens, such as bacteria. In plants, it was shown that alamethicin causes apoptosis-like death of plant cells (Rippa et al., 2010). Alamethicin is a membrane-active peptide produced by the beneficial plant root-colonizing fungus *Trichoderma viride*. It kills pathogenic fungi and bacteria around the root, but can also form pores in the plant membranes, i.e. plasma membrane, inner mitochondrial membrane, and plastid inner envelope (Matic et al., 2005; Aidemark et al., 2010).

3.3. Type III Secretion System

Type III secretion system (T3SS, **Figure 5**) is an organelle present in the most plant as well as animal pathogenic or symbiotic Gram-negative bacteria. It is complex machinery composed of more than 20 different components. Spanning both bacterial membranes, it also contains a filamentous part called an Hrp pilus in plant pathogens or a needle in animal pathogens (He et al., 2004). The filamentous part of plant pathogens reaches up to 2 μm in length, which is much longer than the needle of animal pathogens, which reaches up to 80 nm. A longer filamentous part is needed to overcome the plant cell wall, which is at least 100 nm thick (Ji et al., 2015).

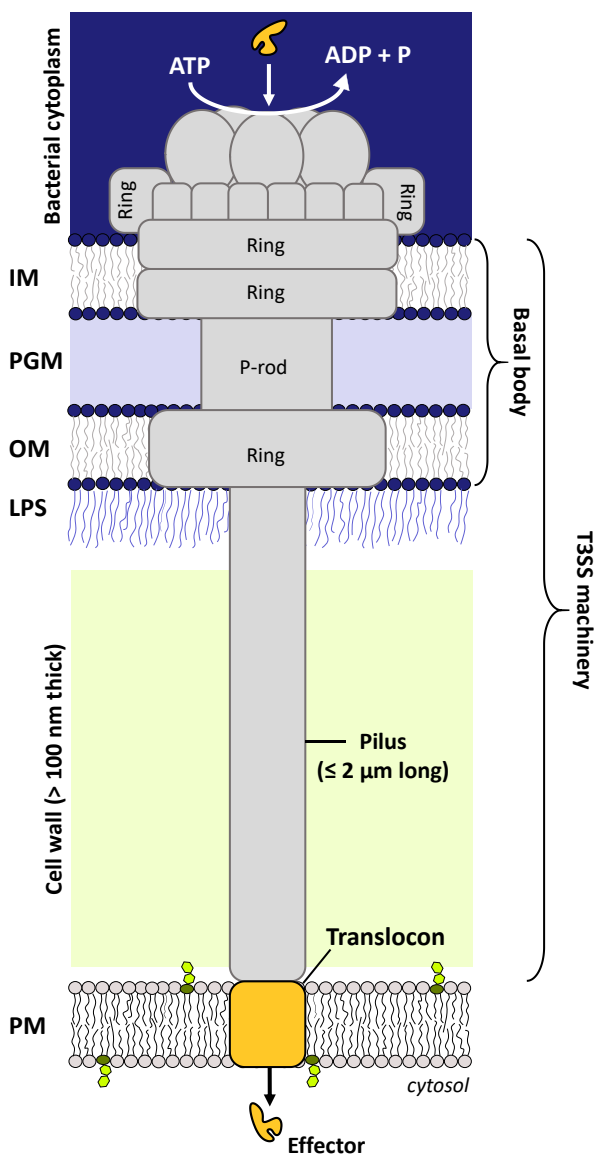

Figure 5: A schematic representation of T3SS machinery. The basal body spans bacterial inner (IM) and outer (OM) membranes and is composed of several rings that are presumably connected by a periplasmic rod (P-rod) across the peptidoglycan mesh (PGM). The filamentous part reaches the host membrane, where it forms a transmembrane translocon to access the host cytosol. In the case of attacking a plant cell, Hrp pilus has to pass the cell wall as well. For the delivery of effector proteins into the host, ATP hydrolysis is needed. LPS – lipopolysaccharide, PM – plant plasma membrane.

3.3.1. Translocon

T3SS can deliver many structurally different effectors directly into the host cell cytoplasm. This is done through translocon, which is a pore, formed at the tip of the filamentous complex (He et al., 2004). T3SS from *Shigella* was shown to be important in animal pathogenesis as well as in the proliferation of *Shigella* in plants (Jo et al., 2019). The pore-forming component of T3SS from *Shigella* is homologous to coiled-coil regions of colicin Ia, a PFP from Gram-negative bacteria that targets bacterial cells. This suggests that colicin Ia and the T3SS pore-forming component could evolve from a common ancestor (Barta et al., 2012). However, T3SS is mechanistically and functionally different from PFPs – its primary role is not to permeabilize and lyse the cell but to deliver effector molecules. Upon reaching the plasma membrane, the pore-forming components recognize the sensors, i.e. plant membrane lipids or proteins. Only then the translocon is formed, and the effectors are injected to the cytoplasm (Ji et al., 2015). After delivering the effectors, the bacterium leaves the site of contact. It was recently observed, that *Pseudomonas aeruginosa* translocon remains anchored into the host cytoplasmic membrane even after that, making the membrane permeable for ions.

3.4. Perforation as a Mechanism of Defense

The immune system of vertebrates uses pore-formation to control infection as well as tumor formation and can kill both pathogen and host cells (Liu et al., 2020). Similarly, it was recently shown that pore-formation is present also in plant defense, as a part of the second layer of plant immunity (ETI) (Burdett et al., 2019).

3.4.1. HOPZ-ACTIVATED RESISTANCE 1 Resistosome

HOPZ-ACTIVATED RESISTANCE 1 (ZAR1) is a sensor NLR with a coiled-coil domain that can sense several effectors. At the same time, it acts like the executor, which can trigger ETI without the need for a helper NLR. It interacts with pseudokinases, including ZED1 and RKS1, and receptor-like cytoplasmic kinases, such as PBL2, to form a pentameric resistosome (Figure 6A). Resistosome forms a pore through the membrane, which allows the influx of calcium ions (Figure 6B). This triggers a defense response and causes cell death (Burdett et al., 2019; van Wersch et al., 2020; Bi et al., 2021).

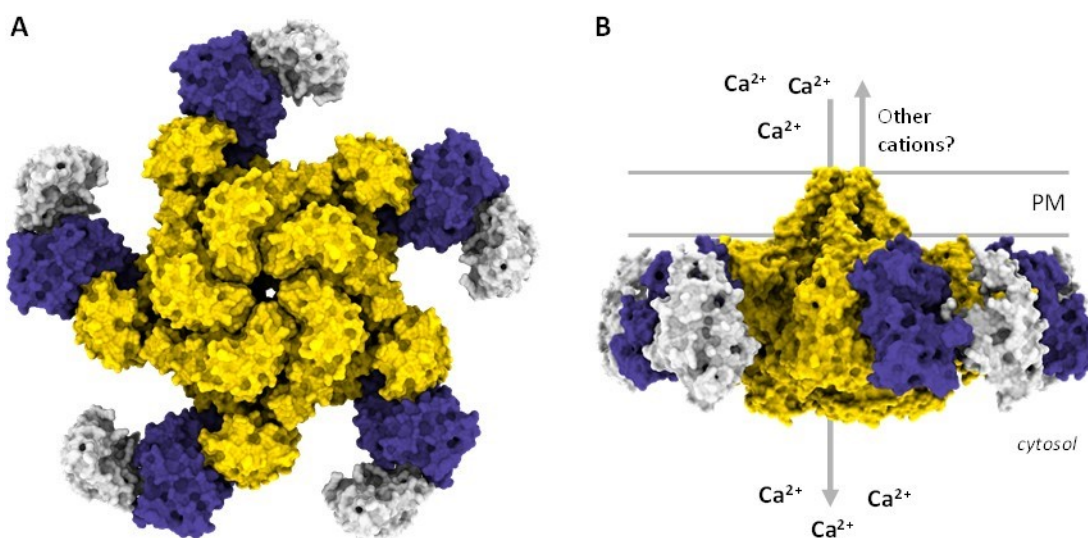

Figure 6: Structure of pentameric ZAR1 resistosome, (A) top view and (B) side view (PDB 6J5T). Resistosome perforates the plant plasma membrane (PM), which allows the influx of calcium ions. Yellow – ZAR1, violet – pseudokinases, grey – receptor-like cytoplasmic kinases.

4. Conclusion

Pathogen-host interactions rely on different mechanisms, one of which is membrane perforation. Such a mechanism can be used either as an attack or a defense mechanism and is relatively well understood among vertebrates and bacteria. The exact knowledge of plant-membrane perforation is still lacking, although it has been stably improving in the past years. It is important, that not only the mechanistic but also structural data is becoming available, which will allow us to understand the pathogen-plant membrane interactions in detail on the molecular level. This will open the possibility to develop greener and more effective strategies for plant pathogen management, which, for our growing population, are of unprecedented value.

Conflicts of Interest: The authors declare no conflict of interest.

References

1. Aidemark M, Tjellström H, Sandelius AS, et al. Trichoderma viride cellulase induces resistance to the antibiotic pore-forming peptide alamethicin associated with changes in the plasma membrane lipid composition of tobacco BY-2 cells. *BMC Plant Biol.* 2010; 10: 274. DOI: 10.1186/1471-2229-10-274
2. Bae H, Kim MS, Sicher RC, Bae HJ, Bailey BA. Necrosis- and ethylene-inducing peptide from *Fusarium oxysporum* induces a complex cascade of transcripts associated with signal transduction and cell death in *Arabidopsis*. *Plant Physiol.* 2006; 141: 1056-1067. DOI: 10.1104/pp.106.076869
3. Barta ML, Dickenson NE, Patil M, et al. The structures of coiled-coil domains from type III secretion system translocators reveal homology to pore-forming toxins. *J Mol Biol.* 2012; 417: 395-405. DOI: 10.1016/j.jmb.2012.01.026
4. Bentham AR, De la Concepcion JC, Mukhi N, et al. A molecular roadmap to the plant immune system. *J Biol Chem.* 2020; 295:4916-14935. DOI: 10.1074/jbc.REV120.010852
5. Bi G, Su M, Li N, et al. The ZAR1 resistosome is a calcium-permeable channel triggering plant immune signaling. *Cell.* 2021; 184: 3528-3541.e12. DOI: 10.1016/j.cell.2021.05.003.
6. Birck C, Damian L, Marty-Detraves C, et al. A new lectin family with structure similarity to actinoporins revealed by the crystal structure of *Xerochomus chryserteron* lectin XCL. *J Mol Biol.* 2004; 344: 1409-1420. DOI: 10.1016/j.jmb.2004.10.007
7. Böhm H, Albert I, Oome S, Raaymakers TM, Van den Ackerveken G, Nürnberger T. A conserved peptide pattern from a widespread microbial virulence factor triggers pattern-induced immunity in *Arabidopsis*. *PLoS Pathog.* 2014; 10: e1004491. Published 2014 Nov 6. DOI: 10.1371/journal.ppat.1004491
8. Boutrot F, Zipfel C. Function, Discovery, and Exploitation of Plant Pattern Recognition Receptors for Broad-Spectrum Disease Resistance. *Annu Rev Phytopathol.* 2017; 55: 257-286. DOI: 10.1146/annurev-phyto-080614-120106
9. Burdett H, Bentham AR, Williams SJ, et al. The Plant "Resistosome": Structural Insights into Immune Signaling. *Cell Host & Microbe.* 2019; 26: 193-201. DOI: 10.1016/j.chom.2019.07.020. PMID: 31415752.
10. Chen JB, Bao SW, Fang YL, et al. An LRR-only protein promotes NLP-triggered cell death and disease susceptibility by facilitating oligomerization of NLP in *Arabidopsis*. *New Phytol.* 2021; 232: 1808-1822. DOI: 10.1111/nph.17680
11. Cox KL. Unexpected help: role of an N-terminally truncated helper NLR in plant immunity. *Plant Cell.* 2022; 34: 1427-1428. DOI: 10.1093/plcell/koab303
12. Kristan KC, Viero G, Dalla Serra M, Macek P, Anderluh G. Molecular mechanism of pore formation by actinoporins. *Toxicon.* 2009; 54: 1125-1134. DOI: 10.1016/j.toxicon.2009.02.026
13. Dal Peraro M, van der Goot FG. Pore-forming toxins: ancient, but never really out of fashion. *Nat Rev Microbiol.* 2016; 14: 77-92. DOI: 10.1038/nrmicro.2015.3
14. Dortet L, Lombardi C, Cretin F, Dessen A, Filloux A. Pore-forming activity of the *Pseudomonas aeruginosa* type III secretion system translocon alters the host epigenome. *Nat Microbiol.* 2018; 3: 378-386. DOI: 10.1038/s41564-018-0109-7



15. Fellbrich G, Romanski A, Varet A, et al. NPP1, a Phytophthora-associated trigger of plant defense in parsley and Arabidopsis. *Plant J.* 2002 ;32: 375-390. DOI: 10.1046/j.1365-313x.2002.01454.x
16. Feng BZ, Zhu XP, Fu L, et al. Characterization of necrosis-inducing NLP proteins in *Phytophthora capsici*. *BMC Plant Biol.* 2014; 14: 126. DOI: 10.1186/1471-2229-14-126
17. Garcia O, Macedo JA, Tibúrcio R, et al. Characterization of necrosis and ethylene-inducing proteins (NEP) in the basidiomycete *Moniliophthora perniciosa*, the causal agent of witches' broom in *Theobroma cacao*. *Mycol Res.* 2007; 111: 443-455. DOI:10.1016/j.mycres.2007.01.017
18. Gijzen M, Nürnberger T. Nep1-like proteins from plant pathogens: recruitment and diversification of the NPP1 domain across taxa. *Phytochemistry.* 2006; 67: 1800-1807. DOI: 10.1016/j.phytochem.2005.12.008
19. Gronnier J, Germain V, Gouguet P, Cacas JL, Mongrand S. GIPC: Glycosyl Inositol Phospho Ceramides, the major sphingolipids on earth. *Plant Signal Behav.* 2016; 11: e1152438. DOI: 10.1080/15592324.2016.1152438
20. He SY, Nomura K, Whittam TS. Type III protein secretion mechanism in mammalian and plant pathogens. *Biochim Biophys Acta.* 2004; 1694: 181-206. DOI: 10.1016/j.bbamcr.2004.03.011
21. Jennings J, Apel-Birkhold P, Bailey B, Anderson J. Induction of ethylene biosynthesis and necrosis in weed leaves by a *Fusarium oxysporum* protein. *Weed Science.* 2000; 48: 7-14. DOI: 10.1614/0043-1745(2000)048[0007:IOEBAN]2.0.CO;2
22. Ji H, Dong H. Key steps in type III secretion system (T3SS) towards translocon assembly with potential sensor at plant plasma membrane. *Mol Plant Pathol.* 2015; 16: 762-773. DOI: 10.1111/mpp.12223
23. Jones JD, Dangl JL. The plant immune system. *Nature.* 2006; 444:23-329. DOI:10.1038/nature05286
24. Jo SH, Lee J, Park E, et al. A human pathogenic bacterium *Shigella* proliferates in plants through adoption of type III effectors for shigellosis. *Plant Cell Environ.* 2019; 42: 2962-2978. DOI: 10.1111/pce.13603
25. Kale SD, Tyler SD. Entry of oomycete and fungal effectors into plant and animal host cells. *Cell Microbiol.* 2011; 13: 1839-1848. DOI: 10.1111/j.1462-5822.2011.01659.x
26. Kűfner I, Ottmann C, Oecking C, Nürnberger T. Cytolytic toxins as triggers of plant immune response. *Plant Signal Behav.* 2009; 4: 977-979. DOI: 10.4161/psb.4.10.9669
27. Lenarčič T, Albert I, Böhm H, et al. Eudicot plant-specific sphingolipids determine host selectivity of microbial NLP cytolysins. *Science (New York, N.Y.).* 2017; 358: 1431-1434. DOI: 10.1126/science.aan6874.
28. Liang X, Zhou JM. Receptor-Like Cytoplasmic Kinases: Central Players in Plant Receptor Kinase-Mediated Signaling. *Annu Rev Plant Biol.* 2018; 69: 267-299. DOI: 10.1146/annurev-arplant-042817-040540
29. Liu X, Lieberman J. Knocking 'em Dead: Pore-Forming Proteins in Immune Defense. *Annu Rev Immunol.* 2020; 38: 455-485. DOI: 10.1146/annurev-immunol-111319-023800
30. Matic S, Geisler DA, Møller IM, Widell S, Rasmusson AG. Alamethicin permeabilizes the plasma membrane and mitochondria but not the tonoplast in tobacco (*Nicotiana tabacum* L. cv Bright Yellow) suspension cells. *Biochem J.* 2005; 389: 695-704. DOI: 10.1042/BJ20050433
31. Medzhitov R, Janeway CA Jr. Innate immunity: the virtues of a nonclonal system of recognition. *Cell.* 1997; 91: 295-298. DOI: 10.1016/s0092-8674(00)80412-2
32. Mesa-Galoso H, Pedrera L, Ros U. Pore-forming proteins: From defense factors to endogenous executors of cell death. *Chem Phys Lipids.* 2021; 234: 105026. DOI: 10.1016/j.chemphyslip.2020.105026
33. Oome S, Van den Ackerveken G. Comparative and functional analysis of the widely occurring family of Nep1-like proteins. *Mol Plant Microbe Interact.* 2014; 27: 1081-1094. DOI: 10.1094/MPMI-04-14-0118-R
34. Oome S, Raaymakers TM, Cabral A, et al. Nep1-like proteins from three kingdoms of life act as a microbe-associated molecular pattern in Arabidopsis. *Proc Natl Acad Sci U S A.* 2014; 111: 16955-16960. DOI: 10.1073/pnas.1410031111
35. Ottmann C, Luberacki B, Kűfner I, et al. A common toxin fold mediates microbial attack and plant defense. *Proc Natl Acad Sci U S A.* 2009; 106: 10359-10364. DOI: 10.1073/pnas.0902362106
36. Pirc K, Clifton LA, Yilmaz N, et al. An oomycete NLP cytolysin forms transient small pores in lipid membranes. *Sci Adv.* 2022; 8: eabj9406. DOI: 10.1126/sciadv.abj9406
37. Ripa S, Eid M, Formaggio F, Toniolo C, Béven L. Hypersensitive-like response to the pore-former peptaibol alamethicin in Arabidopsis thaliana. *Chembiochem.* 2010; 11:042-2049. DOI :10.1002/cbic.201000262
38. Sánchez-Martín J, Keller B. NLR immune receptors and diverse types of non-NLR proteins control race-specific resistance in Triticeae. *Curr Opin Plant Biol.* 2021; 62: 102053. DOI:10.1016/j.pbi.2021.102053
39. Seidl MF, Van den Ackerveken G. Activity and Phylogenetics of the Broadly Occurring Family of Microbial Nep1-Like Proteins. *Annu Rev Phytopathol.* 2019; 57: 367-386. DOI: 10.1146/annurev-phyto-082718-100054
40. Spoel SH, Dong X. How do plants achieve immunity? Defence without specialized immune cells. *Nat Rev Immunol.* 2012; 12: 89-100. DOI: 10.1038/nri3141
41. Steentjes MBF, Herrera Valderrama AL, Fouillen L, et al. Cytotoxic activity of Nep1-like proteins on monocots. *New Phytol.* 2022; 235: 690-700. DOI: 10.1111/nph.18146
42. Sun Y, Zhu YX, Balint-Kurti PJ, Wang GF. Fine-Tuning Immunity: Players and Regulators for Plant NLRs. *Trends Plant Sci.* 2020; 25: 695-713. DOI: 10.1016/j.tplants.2020.02.008



43. Thomma BP, Nürnberger T, Joosten MH. Of PAMPs and effectors: the blurred PTI-ETI dichotomy. *Plant Cell*. 2011; 23: 4-15. DOI: 10.1105/tpc.110.082602
44. van Wersch S, Tian L, Hoy R, Li X. Plant NLRs: The Whistleblowers of Plant Immunity. *Plant Commun*. 2019; 1: 100016. DOI: 10.1016/j.xplc.2019.100016
45. Veit S, Wörle JM, Nürnberger T, Koch W, Seitz HU. A novel protein elicitor (PaNie) from *Pythium aphanidermatum* induces multiple defense responses in carrot, *Arabidopsis*, and tobacco. *Plant Physiol*. 2001; 127: 832-841.
46. Xiang J, Cheng J, Wei L, Li M, Wu J. Functional analysis of the Nep1-like proteins from *Plasmopara viticola*. *Plant Signal Behav*. 2022; 17:2000791. DOI:10.1080/15592324.2021.2000791
47. Yuan M, Ngou BPM, Ding P, Xin XF. PTI-ETI crosstalk: an integrative view of plant immunity. *Curr Opin Plant Biol*. 2021; 62: 102030. DOI:10.1016/j.pbi.2021.102030
48. Zhang J, Zhou JM. Plant immunity triggered by microbial molecular signatures. *Mol Plant*. 2010; 3: 783-793. DOI: 10.1093/mp/ssq035

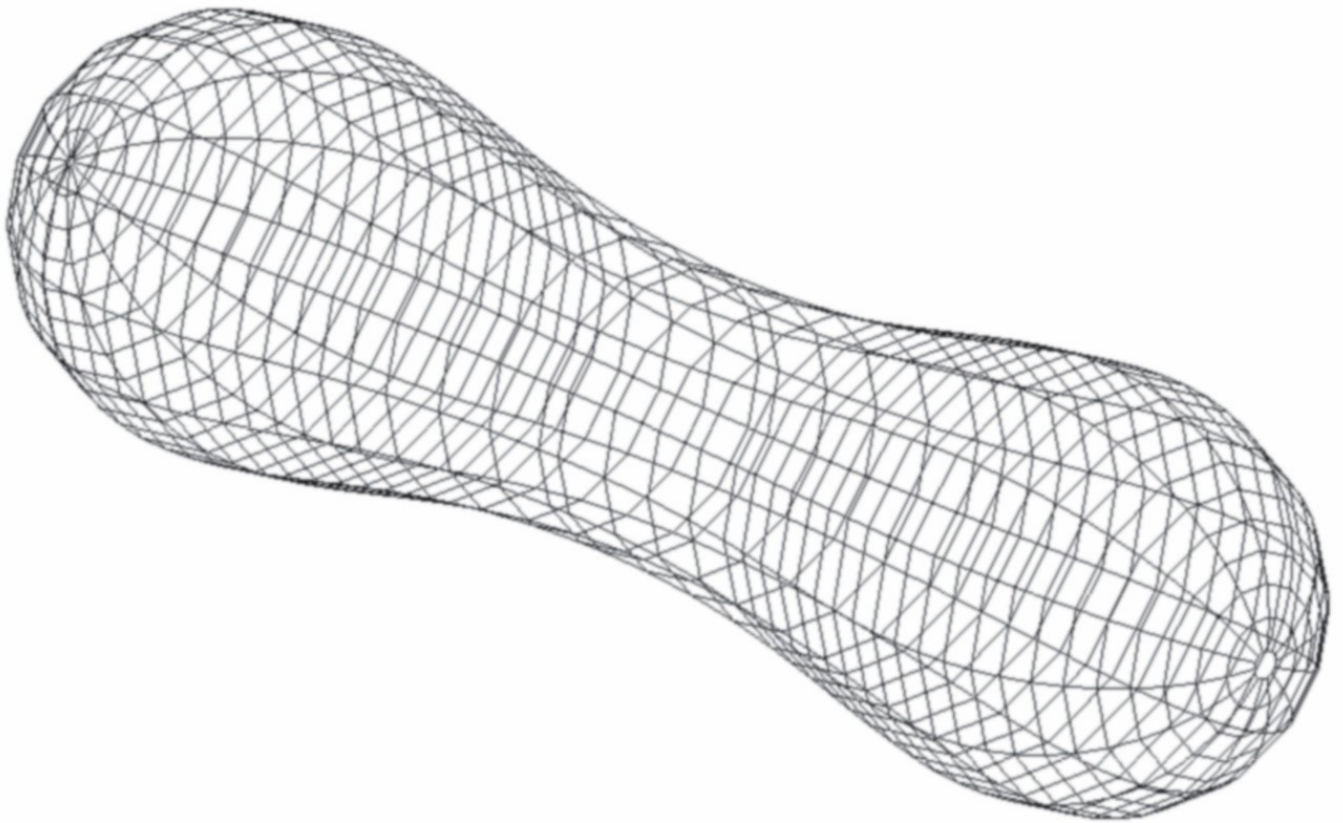



Scientific contribution/Review

Molecular Grammar of RNA-binding Protein Interactions in Formation and Function of Ribonucleoprotein Complexes

Adamek Maksimiljan ^{1,2,*}

1. Department of Molecular Biology and Nanobiotechnology, Laboratory for RNA Networks, National Institute of Chemistry, Ljubljana, Slovenia
 2. PhD Program "Bioinformatics", Faculty of Biotechnology, University of Ljubljana, Ljubljana, Slovenia
- * Correspondence: Maksimiljan Adamek; maksimiljan.adamek@ki.si

Citation: Adamek M. Molecular grammar of RNA-binding protein interactions in formation and function of ribonucleoprotein complexes. Proceedings of Socratic Lectures. 2023, 8; 110-114.
<https://doi.org/10.55295/PSL.2023.II15>

Publisher's Note: UL ZF stays neutral with regard to jurisdictional claims in published maps and institutional affiliations.



Copyright: © 2023 by the authors. Submitted for possible open access publication under the terms and conditions of the Creative Commons Attribution (CC BY) license (<https://creativecommons.org/licenses/by/4.0/>).

Abstract:

Ribonucleoproteins (RNPs) are macromolecular assemblies of proteins along RNA molecules to carry out specialized cellular processes. Understanding how RNA binding proteins (RBPs) and RNA sequences determine the interactions to form RNPs and ultimately steer biomolecular processes remains poorly understood. There is a mounting evidence that RNP assembly depends on the formation of a network of transient, multivalent RBP-RNA and RBP-RBP interactions, particularly between tyrosine residues from intrinsically disordered domains and arginine residues from RNA-binding domains of RBPs. Furthermore, RBPs, especially their intrinsically disordered regions, are hotspots for posttranslational modification (PTM) sites. Although PTMs have been well catalogued, little is known about how these modifications regulate RNP assembly and function. Some initial studies introduced the concept of the so-called phospho-switch, in which RBPs require phosphorylation for condensation of larger RNP complexes, but it remains unclear how this contributes to the protein function and the pattern of selective protein binding to RNA molecules. This short review will take a look at what is currently known in the field of RNPs, their interactions, and the phase-separated biomolecular condensates, which are intimately connected to RNPs and are important for several key cell processes.

Keywords: Ribonucleoproteins; RNA binding proteins; Multivalency; Intrinsically disordered proteins; Posttranslational modifications



1. Introduction

The importance of RNA networks and interactions of RNA molecules is becoming more and more evident. RNA sequencing technologies showed us that much of the genome contains genes for RNA molecules that do not code for protein sequences. These RNA molecules play diverse roles many important cell processes. With the help of more than a thousand RNA binding proteins (RBPs), RNA molecules form various membraneless organelles that allow precise control of the listed processes (Somasundaram et al., 2022; Castello et al., 2016). This short review will give an overview of some basic concepts that are associated with RBP-RNA interactions: phase separation, multivalency and intrinsically disordered regions, and posttranslation modifications.

2. RNA networks

An important goal of studying RNA networks has been to elucidate the functions of RBPs as the core regulators of RNA processing. Proteins that act on RNA can be separated into two groups: 1) effectors, molecules that operate as executors of RNA processing or otherwise directly affect RNA processing, and 2) RBPs, proteins that bind RNA in a sequence- or structure-specific manner and are not basal or auxiliary components of effector assemblies (He et al., 2023).

RNA networks have certain traits as reviewed in He et al.(2023):

1. RNA sequence specificity: RBPs and other RNA molecules act only upon some transcripts, dependent on the transcripts' RNA sequence. This is the most basic regulatory level of RNA networks that determines which transcripts will be controlled by which factors.
2. Relayed RNA processing: Posttranscriptional processing events have to occur in a specific sequence or the cell homeostasis could be threatened. Specific cellular organization contributes to the correct sequence of RNA processing events.
3. Condensate formation: The formation of ribonucleoprotein (RNP) condensates increases local concentration of RBP-RNA modules along with their effector complexes. RNP condensation can stabilize RNA-RBP interactions, contributes to correct RNA folding for further processing, increases the rate of biochemical reactions, and/or assists in storage or transport of molecules.
4. Convergent molecular evolution: This type of evolution has an important role at different levels of RNA processing and contributes to the hierarchical structure of RNA networks. The end result is a unified fate of different transcripts by a common regulatory step.
5. Hierarchical organization: Hierarchically wired networks exhibit fewer connections, adapt faster to the environment, and show higher overall performance compared to non-hierarchical networks.

3. Phase separated ribonucleoparticle condensates

Eukaryotic cells are composed of several organelles, each one with specific functions. Membrane separated organelles provide spatiotemporal control over key cell processes. In addition to these types of organelles, cells also contain organelles that lack a lipid membrane separating them from their surroundings. These organelles are assemblies composed of proteins, nucleic acids, and other molecular components. Examples include assemblies in the nucleus such as the nucleolus, Cajal bodies, and nuclear speckles and also cytoplasmic structures such as stress granules, P-bodies, and germ granules. (Shin and Brangwynne, 2017). Many of such membraneless organelles have liquid-like properties and form by phase separation. This is a physical process that occurs when a saturated solution of components spontaneously separates into two phases: a dense phase and a diluted phase. These phases then coexist in equilibrium (Boeynaems et al., 2018). The molecular drivers of phase separation are so called "scaffolds" and molecules that preferentially partition into condensates created by scaffolds are so called "clients" (Posey et al., 2021). RNP condensates are an example of such phase separated systems. RNPs are macromolecular assemblies of proteins along RNA molecules to carry out specialized cellular processes (Shin and Brangwynne 2017; Banani et al., 2017).



Mechanisms that govern the formation and dissolution of RNP condensates include: membrane surfaces, protein chaperones, RNA helicases, and post-translational modifications of condensate components (He et al., 2023). The formation of membraneless RNP condensates was shown to execute specialized tasks such as DNA replication and repair, chromatin remodelling, transcription, and mRNA splicing (Somasundaram et al., 2022). In the following few paragraphs, there are several listed examples of such RNP condensates to illustrate their ubiquity and importance for key cell processes.

Transcription is thought to take place at discrete nuclear sites known as transcription factories, in the form of phase-separated condensates that allow compartmentalization and coupling of polymerases engaged at multiple genomic sites. It was shown by Shao et al. that RBPs constitute half of the chromatin proteome in embryonic stem cells. Based on their findings, researchers proposed that gene promoter-associated RNA molecules and their binding proteins enhance the phase separation of RNA polymerase condensates to promote active transcription (Shao et al., 2022).

Very recently, it was shown that MED1, an important part of the gene activation complex, called Mediator, selectively partitions RNA polymerase II into RNP condensates. This partitioning occurs together with partitioning of RNA polymerase II positive allosteric regulator while the negative regulators are excluded. Researchers showed that the IDRs of partitioned proteins are necessary and sufficient for selective compartmentalization and require alternating block of charged amino acids. By disrupting this charge pattern, researchers were able to prevent RNP partitioning (Lyons et al., 2023).

RNP condensation is not limited to eukaryotic cells. In bacteria, mRNA decay is controlled by megadalton scale macromolecular assemblies called RNA degradosomes, composed of nucleases and other RNA decay associated proteins. Research into bacterial cell biology has shown that RNA degradosomes can assemble into phase-separated structures, which were then termed bacterial ribonucleoprotein bodies. These bodies were shown to have many analogous properties to eukaryotic RNPs, such as processing bodies (these contain proteins involved in RNA turnover) and stress granules (these contain RNA molecules that are stalled in the pre-initiation complexes) (Muthunayake et al., 2020).

4. Multivalency and intrinsically disordered proteins

Our understanding how RBP and RNA sequences determine the interactions amongst themselves remains poorly understood. Research into this subject provided evidence that RNP assembly depends on the formation of a network of transient, multivalent RBP-RNA and RBP-RBP interactions (Brangwynne et al., 2015; Wang et al., 2018). This part of the review expands on the concept of multivalency: the presence of multiple sites that mediate interactions with other proteins. (Dasmeh et al., 2022).

RNP condensation is driven primarily by intrinsically disordered regions (IDRs) of different RBPs. These regions associate into multimeric complexes through weak, non-specific interactions, through transient secondary structures formed within IDRs, and through contributing interaction from the associated RNA molecules (He et al., 2023). Long noncoding RNAs with unique secondary structures are thought to be especially important in the phase separation process by binding to RBPs (Somasundaram et al., 2022). For some condensates in vitro, RNA molecules, not proteins, are required for maintenance of condensates (Cabral et al., 2022). Introducing unstructured regions into mRNA molecules can also affect processes such as translation initiation, pointing also to the importance of RNA structure in such condensates (Lai et al., 2022).

Multivalency in the form of bivalent binding is a common RNA binding strategy among RBPs, resulting in a higher binding affinity and sequence recognition specificity (Sohrabi-Jahromi and Söding, 2021). Multivalency can vary substantially between protein orthologs, however the length scale at which sequence motifs that enable such protein-protein interactions occur is conserved (Dasmeh et al., 2021).

An important study for multivalency mechanisms in RBPs was performed by Wang et al. in 2018. Researchers showed for protein FUS (belongs to the FUS protein family, a class of intrinsically disordered scaffold proteins) that its phase transitioning is primarily governed by multivalent interactions among tyrosine residues from prion-like domains and arginine residues from RNA-binding domains, which are modulated by negatively



charged residues. Glycine residues enhanced the fluidity, whereas glutamine and serine residues promoted hardening into less dynamic structures. Based on their observations, researchers prepared a model to show that the measured saturation concentrations of phase separation are inversely proportional to the product of the numbers of arginine and tyrosine residues. Their results suggested a possibility to predict phase-separation properties based on protein amino acid sequences (Wang et al., 2018). Other research into this topic has also showed that positively charged amino acid residues in intrinsically disordered proteins (IDPs) could further enhance recruitment of other IDPs, possibly with cation- π interactions. Poly-ethylene glycol (a crowding reagent used for in vitro phase separation) also increased IDP recruitment, which indicates the need for crowding conditions. Tyrosine residues of IDP proteins also strongly participated in recruitment of other IDPs (Jo et al., 2022).

5. Posttranslational modifications

In the final section, this review will touch upon the effect of posttranslational modifications (PTMs) for RNP condensations. IDPs frequently contain sites PTMs such as phosphorylation, and these modifications exhibit a high preference for IDR residues (Castello et al., 2016; Vieira-Vieira et al., 2022). Arginine methylation has also been noted to play a role in RBP regulation (Gayatri and Bedford, 2014). Generally, PTMs are implicated in regulating protein function by modulating the protein conformation, protein-protein interactions and the transition between ordered and disordered states of IDPs (Miao et al., 2018). However, despite PTMs being well known and catalogued, little is known about how these modifications regulate RNP assembly and function. Previous studies introduced the concept of the phospho-switch, in which RBPs require phosphorylation for condensation of larger RNP complexes (Monahan et al., 2017; Larson et al., 2017). Recently, it was shown that multi-phosphorylation of the C-terminus disordered segment of heteronuclear ribonucleoprotein A1, a key RNA-splicing factor, reduces its ability to locate to nuclear clusters. Similarly, phosphorylation of nucleophosmin 1, a nucleolar protein, was shown to be crucial for lowering its partitioning to the nucleolus and additional phosphorylation of distal sites enhanced its retention in the nucleoplasm (Sridharan et al., 2022). Studies such as these show a clear effect of PTMs on RNP formation, but it remains unclear how this contributes to the protein function and the pattern of selective protein binding to RNAs (Vieira-Vieira et al., 2022; Modic et al., 2021).

6. Conclusions

To conclude this short review, studying RNA networks, their regulation, interactions, and their constitutive elements is a challenging field, requiring multidisciplinary approaches, including approaches from cell biology, biophysics, bioinformatics, and others. Despite its challenges, this field of research is a “hot topic”, as indicated by numerous research and review articles that were published in previous few years, especially in 2022 (see references). As compromised function of RBPs underlies the origin of many diseases (He et al., 2022), research into RNA networks will ultimately lead to development of novel therapies for many diseases.

Funding: The author is the recipient of the National Institute of Chemistry’s 2022 Janko Jamnik Doctoral Scholarship for a promising young researcher in the field of chemistry and related sciences. The author is supported by the ERC Advanced Grant RNPdynamics (198000).

Conflicts of Interest: The author declares no conflict of interest.

References

1. Banani SF, Lee O H, Hyman AA, Rosen MK. Biomolecular condensates: organizers of cellular biochemistry. *Nature Reviews Molecular Cell Biology*. 2017; 18: 285–298. DOI: 10.1038/nrm.2017.7
2. Boeynaems S, Alberti S, Fawzi NL, et al. Protein Phase Separation: A New Phase in Cell Biology. *Trends in Cell Biology*. 2018; 28: 420–435. DOI: 10.1016/j.tcb.2018.02.004



3. Brangwynne CP, Tompa P, Pappu RV. Polymer physics of intracellular phase transitions. *Nature Physics*. 2015; 11: 899–904. DOI: 10.1038/nphys3532
4. Cabral SE, Otis JP, Mowry KL. Multivalent interactions with RNA drive recruitment and dynamics in biomolecular condensates in *Xenopus* oocytes. *iScience*. 2022; 25: 104811. DOI: 10.1016/j.isci.2022.104811
5. Castello A, Fischer B, Frese CK, et al. Comprehensive Identification of RNA-Binding Domains in Human Cells. *Molecular Cell*. 2016; 63: 696–710. DOI: 10.1016/j.molcel.2016.06.029
6. Dasmeh P, Doronin R, Wagner A. The length scale of multivalent interactions is evolutionarily conserved in fungal and vertebrate phase-separating proteins. *Genetics*. 2022; 220: 1–7. DOI: 10.1093/genetics/iyab184
7. Gayatri S, Bedford M T. Readers of histone methylarginine marks. *Biochimica et Biophysica Acta*. 2014; 1839: 702–710. DOI: 10.1016/j.bbagr.2014.02.015
8. He S, Valkov E, Cheloufi S, Murn J. The nexus between RNA-binding proteins and their effectors. *Nat Rev Genet*. 2023. 24: 276–294. DOI: 10.1038/s41576-022-00550-0
9. Jo Y, Jang J, Song D, et al. Determinants for intrinsically disordered protein recruitment into phase-separated protein condensates. *Chemical Science*. 2022; 13: 522–530. DOI: 10.1039/D1SC05672G
10. Lai W-JC, Zhu M, Belinite M, et al. Intrinsically Unstructured Sequences in the mRNA 3' UTR Reduce the Ability of Poly(A) Tail to Enhance Translation. *Journal of Molecular Biology*. 2022; 434: 167877. DOI: 10.1016/j.jmb.2022.167877
11. Larson AG, Elnatan D, Keenen MM, et al. Liquid droplet formation by HP1 α suggests a role for phase separation in heterochromatin. *Nature*. 2017; 547: 236–240. DOI: 10.1038/nature22822
12. Lyons H, Veettil R T, Pradhan P, et al. Functional partitioning of transcriptional regulators by patterned charge blocks. *Cell*. 2023; 186: 1–19. DOI: 10.1016/j.cell.2022.12.013
13. Miao Y, Tipakornsawapak T, Zheng L, et al. Phospho-regulation of intrinsically disordered proteins for actin assembly and endocytosis. *The FEBS Journal*. 2018; 285: 2762–2784. DOI: 10.1111/febs.14493
14. Modic M, de Los Mozos IR, Steinhauser S, et al. Epiblast morphogenesis is controlled by selective mRNA decay triggered by LIN28A relocation. *bioRxiv preprint*. 2021. DOI: 10.1101/2021.03.15.433780
15. Monahan Z, Ryan VH, Janke AM, et al. Phosphorylation of the FUS low-complexity domain disrupts phase separation, aggregation, and toxicity. *The EMBO journal*. 2017; 36: 2951–2967. DOI: 10.15252/EMBJ.201696394
16. Muthunayake NS, Tomares DT, Childers WS, Schrader JM. Phase-separated bacterial ribonucleoprotein bodies organize mRNA decay. *WIREs RNA*. 2020; 11: e1599. DOI: 10.1002/wrna.1599
17. Posey AE, Holehouse AS, Pappu RV. Phase Separation of Intrinsically Disordered Proteins. In: *Methods in Enzymology Volume 611: Intrinsically Disordered Proteins*; 2018; pp. 1–30.
18. Shao W, Bi X; Pan Y, et al. Phase separation of RNA-binding protein promotes polymerase binding and transcription. *Nature Chemical Biology*. 2022; 18: 70–80. DOI: 10.1038/s41589-021-00904-5
19. Shin Y, Brangwynne C P. Liquid phase condensation in cell physiology and disease. *Science*. 2017; 357: eaaf4382. DOI: 10.1126/science.aaf4382
20. Sohrabi-Jahromi S, Söding J. Thermodynamic modeling reveals widespread multivalent binding by RNA-binding proteins. *Bioinformatics*. 2021; 37: i308–i316. DOI: 10.1093/bioinformatics/btab300
21. Somasundaram K, Gupta K, Jain N, Jana S. LncRNAs divide and rule: The master regulators of phase separation. *Frontiers in Genetics*. 2022; 13: 930792. DOI: 10.3389/fgene.2022.930792
22. Sridharan S, Hernandez-Armendariz A, Kurzawa N, et al. Systematic discovery of biomolecular condensate-specific protein phosphorylation. *Nature Chemical Biology*. 2022; 18: 1104–1114. DOI: 10.1038/s41589-022-01062-y
23. Vieira-Vieira C H, Dauksaite V, Sporbart A, et al. Proteome-wide quantitative RNA-interactome capture identifies phosphorylation sites with regulatory potential in RBM20. *Molecular Cell*. 2022; 82: 2069–2083.e1–e8. DOI: 10.1016/j.molcel.2022.03.024
24. Wang J, Choi J-M, Holehouse AS, et al. A Molecular Grammar Governing the Driving Forces for Phase Separation of Prion-like RNA Binding Proteins. *Cell*. 2018; 174: 688–699. DOI: 10.1016/j.cell.2018.06.006

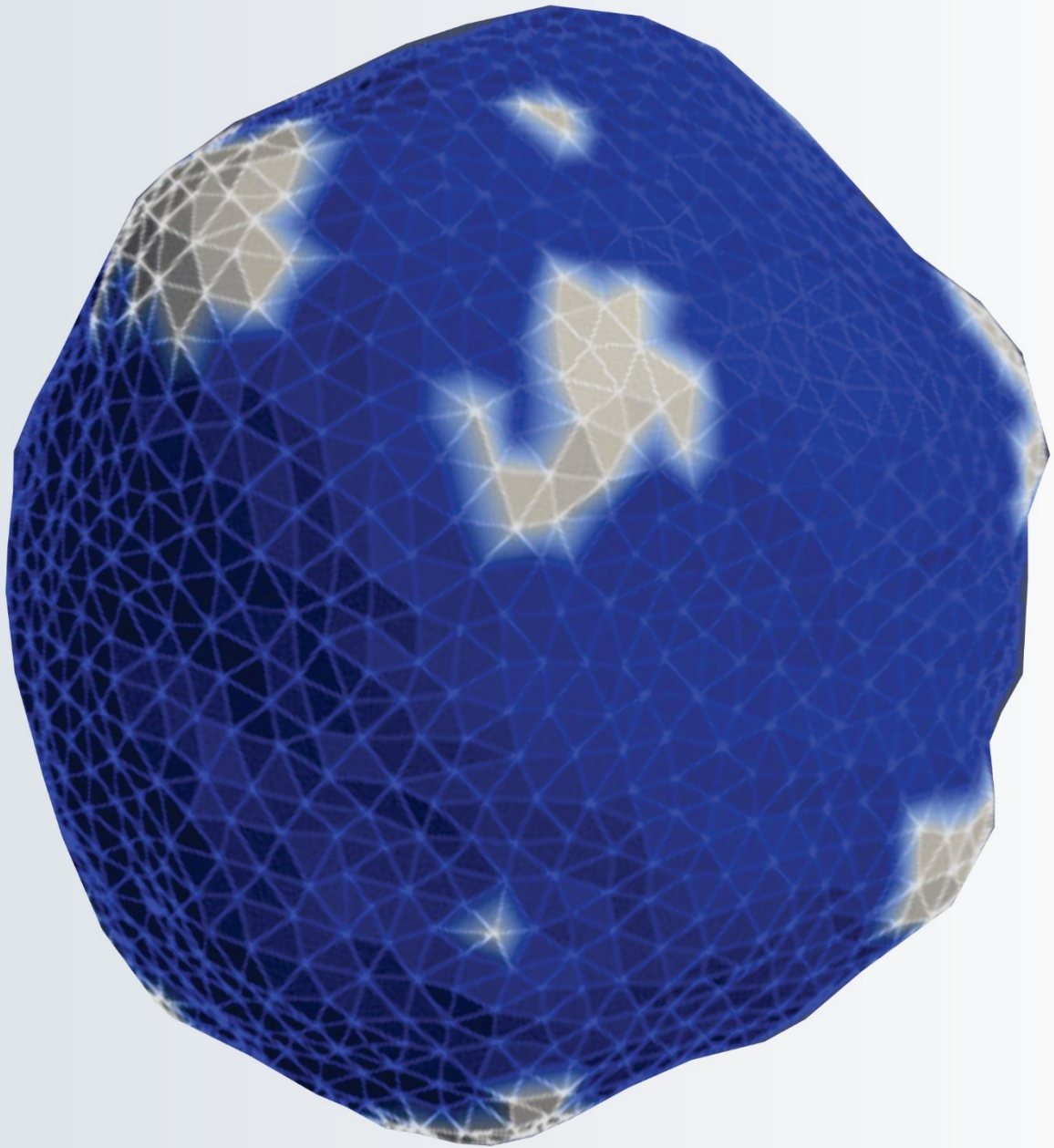



Review

Extracellular Vesicles for Cosmetic Applications

Bedina Zavec Apolonija^{1*}¹ National Institute of Chemistry, Department of Molecular Biology and Nanobiotechnology, Ljubljana, Slovenia* Correspondence: Apolonija Bedian Zavec; polona.bedina@ki.si**Abstract:**

Extracellular vesicles (EVs) are nanosized membrane vesicles that carry membrane and cargo molecules inherited from their parental cells. Excellent delivery capacity, biological origin, and nanosized dimensions support the great potential of EVs as medical and cosmetic active ingredients. Many studies have already reported improved skin conditions by using EVs for skin rejuvenation, scar removal, and anti-pigmentation treatments. In this review, EVs from mesenchymal stem cells, platelets, skin microbiota, and microalgae will be considered. The most promising results come from mesenchymal stem cell (MSC) derived EVs that have impressive antiaging and wound-healing effects on the skin, but their use for medical or cosmetic purposes is not yet allowed in Europe and the United States. Autologous platelet- and extracellular vesicle-rich plasma (PVRP) is well tolerated and capable of rejuvenating the face; intradermal injections and topical applications are currently being considered in clinical and cosmetic dermatology. Symbiotic microorganisms of the human skin have many beneficial effects on the skin, but the presence of bacteria in cosmetic products is restricted; therefore, the preparation of EVs from skin-beneficial microbes is particularly relevant, and there are already many cosmetic products containing lysates from different probiotics on the market. Microalgae can produce many valuable bioactive compounds, antioxidants such as carotenoids are particularly interesting; therefore, microalgae are promising producers of EVs that could be used in cosmetic products.

Citation: Bedina Zavec A. Extracellular vesicles for cosmetic applications. Proceedings of Socratic Lectures. 2023, 8; 116-123.
<https://doi.org/10.55295/PSL.2023.II16>

Publisher's Note: UL ZF stays neutral with regard to jurisdictional claims in published maps and institutional affiliations.



Copyright: © 2023 by the authors. Submitted for possible open access publication under the terms and conditions of the Creative Commons Attribution (CC BY) license (<https://creativecommons.org/licenses/by/4.0/>).

Keywords: Extracellular vesicles; Skin health; Microbiota; Mesenchymal stem cells; Microalgae



1. Introduction

Human skin is an effective barrier that protects the body from the external environment. In addition to protecting the body from environmental damage, skin is also extremely important for our appearance; therefore, cosmetics have been used for thousands of years to promote our appearance more attractive. Nanotechnology is an actual strategy for the development of cosmetics formulation because nanoparticles allow more efficient penetration through the skin and effective release of ingredients, which contributes to superior technological and cosmetic effects (Santos et al., 2019). Extremely interesting nanoparticles for cosmetic use are extracellular vesicles (EVs) due to their biological origin and capability to modulate recipient cells.

Extracellular vesicles (EVs) are membrane vesicles, 40-1000 nm in size, released from the cells into their microenvironment. Normal cells of multicellular organisms, malignant cells, as well as unicellular organisms, release EVs from their surface. EVs are potent carriers of biologically active molecules because they carry membrane and cargo molecules (proteins, lipids, and nucleic acids), which inherit the molecular information from their parental cells but are enriched in specific proteins and mRNAs. Uptake of EVs by endocytosis or fusion with plasma membrane can induce activation of specific signal transduction cascades of recipient cells and thereby influence the metabolism of target cells and their physiologic state (Kharaziha et al., 2012; Gangoda et al., 2015).

EVs are released into their microenvironment continuously or they are rapidly released by the cells during cell activation. EV secretion is highly environmentally dependent and can be regulated by various stimulants such as chemical treatments, or heat, oxidative, and mechanical stress (Hahm et al, 2021; Zavec et al., 2016). For the production of EVs *in vitro*, it is important that external conditions can influence the amount of released EVs and the properties of EVs. It was found that EVs are excessively formed in connection to cell activation, high or low temperature and pH, cell starvation, pharmacologic agents, oxidative stress, electrical stimulus, electromagnetic waves exposure, and exposure to shear forces (Erwin et al., 2022; Božič et al, 2020; Yáñez-Mó et al., 2015). Besides, EVs released upon different treatments are capable of producing a spectrum of EVs with functional heterogeneity, and secreted EVs reflect the prevailing state of the cell (Kolonic et al., 2020). It was shown that the same population of neutrophils is able to generate EVs with different functional properties, EVs with pro-inflammatory or EVs with anti-inflammatory effects on neighboring cells (Kolonic et al., 2020). The characteristic of EVs to reflect the status of the environmental conditions, allows us to influence the quantity and properties of the produced EVs by changing the cell culture conditions.

The efficacy of EVs in and through the skin has not yet been thoroughly studied. EVs are similar in size and composition to liposomes but are significantly more complex. Liposomes are mostly unable to penetrate the skin (Dreier et al., 2016), so we expect that EVs also have poor penetration into the lower layers of the skin. However, the passage of both liposomes and EVs into the lower layers of the skin can be increased with microneedling (Yernen et al, 2022; Qu F et al, 2022; Kelm and Ibrahim, 2022).

Excellent delivery capacity to the cells, biological origin and nanosized dimensions support the great potential of EVs as medical and cosmetic active ingredients. EV applications have been widely investigated in aesthetic medicine and cosmetics, and many studies have already reported improved skin conditions by using EVs for skin rejuvenation, scar removal, and anti-pigmentation treatments (Kee et al., 2022). In this reflection EVs from mesenchymal stem cells, platelets, skin microbiota, and microalgae (**Figure 1**) will be reviewed.

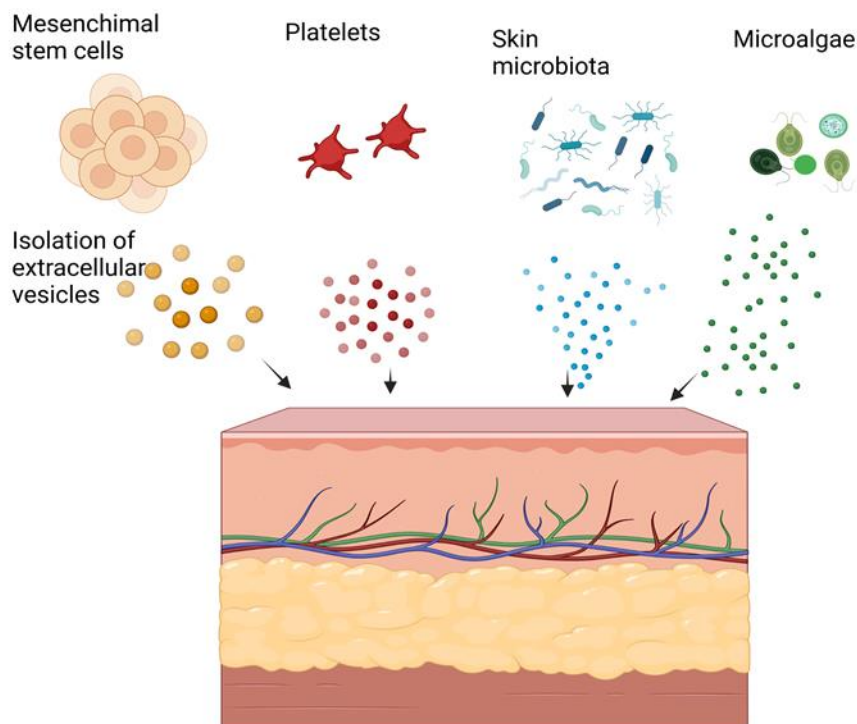

Figure 1. Schematic presentation of interaction of different types of EVs with skin.

2. Mesenchymal stem cells and their EVs

The therapeutic potential of EVs are reviewed several times, and the most promising results come from a mesenchymal stem cell (MSC) derived EVs that are transiting rapidly toward clinical applications (Wiklander et al., 2019). Mesenchymal stem cells (MSCs) are multipotent stem cells with high regenerative capacity that can be obtained from diverse sources, including bone marrow, adipose tissue, umbilical cord blood, synovium, dermis, periodontal ligament and dental pulp (Nancarrow-Lei et al., 2017). The most popular source of MSCs is adipose tissue due to its easy availability. MSCs can differentiate into a variety of mesenchymal lineages such as osteoblasts, chondrocytes, and adipocytes; therefore, they have the ability to repair specific tissues such as bone and cartilage (Song et al., 2006). Recently, MSCs have been recognized as therapeutic agents for skin regeneration and rejuvenation. MSCs have healing capacities for damaged and aged skin because they increase cell proliferation and decrease inflammation, they cause the production of collagen and elastic fibers and they cause the inhibition of metalloproteinase activation in the skin (Jo et al., 2021).

EVs from MSCs are studied for use in cell-free regenerative medicine, also for skin regeneration because it was shown that EVs from MSCs have antiaging and wound-healing effects on the skin. It was shown that EVs derived from amniotic cells accelerate wound healing and inhibit scar formation (Zhao et al., 2017); EVs from human adipose-derived MSCs promote the proliferation of skin fibroblasts (Choi et al., 2018a); EVs from adipose MSCs accelerate skin wound healing and reduce the cellular senescence by optimizing fibroblast properties (Li et al., 2018)

Most of the studies carried out so far are preclinical and the use of EVs is not yet allowed (in Europe and the United States) for either medical or cosmetic purposes; however, there are already preparations on the cosmetic market that contain active ingredients prepared from stem cells and their extracellular vesicles. Kimera Labs already produces such extracellular vesicles for the market, but for now only for research organizations studying the effects of EVs in various fields of medicine and cosmetics.



3. Platelet and EV-rich plasma

Platelet-rich plasma (PRP) is extensively applied as a bioactive scaffold in regeneration of different tissues. Autologous PRP is prepared from subject's own blood. Platelets are concentrated and can be exogenously activated by the addition of calcium mixtures prior to the application. Platelets contain more than 300 biologically active molecules, many growth factors, that are released upon activation and regulate the tissue regeneration process (Nurden et al., 2008); therefore, autologous PRP applications have the potential to play an important role in a variety of regenerative medicine treatments. PRP contains a specific concentration of EVs which are probably important contributors to PRPs effects; therefore the term 'platelet- and extracellular vesicle-rich plasma' (PVRP) has been suggested (Vozel et al., 2021; Troha et al., 2023).

PVPR applications have been widely investigated in clinical dermatology and aesthetic medicine for their beneficial use in skin regeneration and skin rejuvenation. It was shown that treatment with products that contain PVRP led to a significant improvement in the overall facial appearance, and biophysical measurements showed significantly improved skin elasticity (Hersant et al., 2021). It was shown that a single intradermal injection of autologous PVRP is well tolerated and capable of rejuvenating the face; the most significant results were with the correction of wrinkles of the nasolabial folds in younger subjects (Elnehrawy et al., 2017; Sclafani, 2010). Intradermal injections of PVRP cause a significant improvement in infraorbital color homogeneity, while no significant changes were observed in the crow's feet wrinkle (Mehryan et al., 2014). Intradermal injections of autologous PVRP have been shown to be an effective treatment for photodamaged skin (Díaz-Ley et al., 2015). The hyperpigmentation of melasma also significantly improved with intradermal PVRP compared with normal saline (Sirithanabadeekul et al., 2020). Topical applications of PVRP also produce favorable results, especially when combined with microneedling. Improvement in the appearance of acne scars, improvement in the appearance of hyperpigmentation, improvement in the appearance of striae on the buttocks, and improvement in the appearance of androgenetic alopecia was shown after six sessions of monthly microneedling with topical PVRP administration (Kelm and Ibrahim, 2022).

In conclusion, autologous PVPR as a therapeutic liquid is currently being considered in different fields of medicine, also in clinical and cosmetic dermatology. We anticipate that the topical application of PVRP will prevail over intradermal application in the future due to its simpler application.

4. Skin microbiota and bacterial EVs

The human microbiota is the full array of microorganisms that live on and in humans. There is a remarkably diverse array of microorganisms that includes bacteria, archaea, fungi, viruses, and some protozoans. The majority of microorganisms found in the human body live in the gut. The intestinal microbiota protects the intestinal walls from invasion by pathogens, helps in the digestion of food, and produces some vitamins (B12, K) that can not be produced by human cells. Altered intestinal microbiota can result in the development of different diseases like diabetes, asthma, and chronic gut inflammation (Motta et al., 2015).

Human skin is also inhabited by a huge number of bacteria, fungi, and viruses that compose the skin microbiota. Beneficial microorganisms on the skin contribute to the first line of defense against attacking pathogens, and there are complex ecological interactions, the competition within and between microbial species is important for the development and maintenance of a healthy microbiome (Schommer and Gallo, 2013). The microbes of the skin have a significant impact on skin physiology and pathophysiology, and instability of the skin microbiota is associated with skin diseases (Byrd et al., 2018). It was shown that in patients (with atopic dermatitis, psoriasis) the microbial balance is disrupted and the skin is, therefore, more susceptible to infections with pathogenic microorganisms (Paller et al., 2019; Chen et al., 2020).

Major examples of skin microorganisms are Actinobacteria (51.8%; the most common *Corynebacteria* and *Propionibacteria*), Firmicutes (24.4%; the most common *Staphylococci*), Proteobacteria (16.5%), and Bacteroidetes (6.3%) (Grice et al., 2009). Microorganisms of the



skin are related to microorganisms in the intestine and they can affect the entire organism through the metabolites they secrete; some of these metabolites get into the blood and affect the body's functioning via olfactory receptors (Lemoine et al., 2020). Skin microbiota varies between different sites on the skin, and between individuals, it varies according to skin type (racial diversity), social status (or skin treatment), and according to age (Kim et al., 2019). It was shown that probiotics can restore acidic skin pH, alleviate oxidative stress, attenuate photoaging, improve skin barrier function, and enhance hair quality; symbiotic microorganisms are able to slow the skin manifestations of both intrinsic and extrinsic aging (Sharma et al., 2016). Therefore, it is extremely important that our skin is inhabited by symbiotic and commensal microorganisms.

Due to legislative restrictions on the presence of bacteria in cosmetic products, currently only cosmetic products with extracts of microorganisms are present on the market, while products with live microorganisms are not yet available in Europe; therefore, the preparation of EVs from skin-beneficial microbes is particularly relevant.

Bacterial extracellular vesicles (BEVs) are membrane vesicles filled with bacteria-derived components. They are released by Gram-negative and Gram-positive bacteria, they contain diverse components originating from the cell envelope and cytoplasm, and have an important role in the interaction of bacteria with each other and with the host (Sartorio et al., 2021). BEVs have been shown to carry virulence factors and promote infection and disease development, inflammatory response, and act as immune elicitors (Deo et al., 2020; Laughlin and Alaniz, 2016). It was shown that EVs of gut bacteria are implicated in host metabolic homeostasis with their actions on the intestinal barrier, inflammation, and insulin resistance (Villard et al., 2021). The metagenomic study has shown that the composition of fecal-microbe-derived EVs and their effects on Caco-2 cells depends on the disease of the patients (Rodríguez-Díaz et al., 2023). Obviously, BEVs are important factors in the pathophysiology of metabolic diseases and could represent an interesting strategy for promoting human health. EVs of skin bacteria also carry the properties of the original bacteria and can transfer them to the host cells. It was shown that *Propionibacterium acnes*-derived BEVs promote acne-like phenotypes in the human epidermis (Choi et al., 2018b); therefore, BEVs of symbiotic bacteria of the skin microbiota can be expected to induce positive effects on the human skin.

BEVs can be obtained by isolation from the supernatant of a microbial culture, it is possible to harvest EVs sequentially, and preserve microorganisms that grow poorly in bioreactors. On the other hand, BEVs of microorganisms, easily grown in bioreactors, can be prepared in large quantities by mechanical extrusion. As regards skin microbiota, the skin genus *Staphylococcus* is cultivated more easily than *Propionibacterium* or *Corynebacterium* (Byrd et al., 2018). There are many cosmetic products containing lysates from different probiotics on the market already, and it is expected that the amount of such cosmetic products on the market will grow significantly.

5. Microalgae and their EVs

Microalgae are unicellular photosynthetic microorganisms found in marine and freshwater environments with enormous biodiversity that can produce tremendous diversity of valuable bioactive compounds. They can produce antioxidants, especially carotenoids, enzymes, fatty acids, sterols, polysaccharides, and lectins (Cardozo et al., 2007); therefore, microalgae are recognized as promising components for medical and cosmetical formulations as natural and environmentally friendly products that could replace synthetic products (Martínez-Ruiz et al., 2022). In skin exposed to UV radiation and other harmful environmental factors, the level of oxidative compounds increases. Many studies have linked reactive oxygen species (ROS) to various inflammatory skin diseases (atopic dermatitis, psoriasis, and vitiligo), skin aging, and carcinogenesis (Choo et al., 2020). However, microalgae contain many antioxidant agents that could prevent cell destabilization caused by reactive oxygen species and therefore reduce their negative impact on the skin. Antioxidant agents found in microalgae are chlorophyll, carotenoids, squalene, vitamins, flavonoids, polyphenols, and sterols (Sansone and Brunet, 2019). The genus *Chlorella*, *Dunaliella*, *Phaeodactylum*, and *Spirulina* are often used in cosmetics. It was shown that carotenoids (*Chlorella*, *Dunaliella*) are able to control chronic inflammation by inhibiting pro-inflammatory cytokines; astaxanthin (in most microalgae; *Haematococcus*



pluvialis is known to produce the highest content of astaxanthin) reduces the UVB-induced production of pro-inflammatory cytokines; lutein (in *Chlorella*, *Dunaliella*) has strong antioxidant activity; sulfated polysaccharide from the cell walls of microalgae (*Chlorella*, *Phaeodactylum*) have strong anti-inflammatory activity (Choo et al., 2020). Beneficial properties of different microalgae have gained the development of microalgae-based formulations which will be resulted in more commercial products in a short period of time (Yarkent et al., 2020).

The amount of bioactive components in microalgae varies considerably among different species but also within the same species that inhabited different ecosystems. The amount of bioactive components in microalgae can be regulated by modification of cultivation conditions (temperature, nutrient availability, salinity, and lighting regime); it was shown that the production of carotenoid lutein, was regulated by different cultivation conditions (Schuler et al., 2020).

Microalgae release EVs that contain diverse components originating from the shedding cell as all other types of cells. It was confirmed that photosynthetic microalgae release EVs; however, some strains are better suited for the isolation of EVs (Picciotto et al., 2021). The same study also showed that microalgae are promising producers of EVs that could be used as delivery systems of biologically active compounds, which could be used for different industrial sectors such as nutraceuticals, cosmetics, or nanomedicine.

Funding: This research was supported by Slovenian Research Agency through the project No. J3-3066.

Conflicts of Interest: The authors declare no conflict of interest.

References

1. Byrd A, Belkaid Y, Segre J. The human skin microbiome. *Nat Rev Microbiol.* 2018; 16:143–155. DOI: 10.1038/nrmicro.2017.157
2. Božič D, Hočevar M, Kononenko V et al. Chapter Five - Pursuing mechanisms of extracellular vesicle formation. Effects of sample processing, ditor(s): Bongiovanni A, Pocsfalvi G, Manno M, Kralj-Iglič V, *Advances in Biomembranes and Lipid Self-Assembly.* 2020; 32: 113-155. DOI: 10.1016/bs.abl.2020.09.003
3. Cardozo KHM, Guaratini T, Barros MP, et al. Metabolites from algae with economical impact. *Comp Biochem Physiol C Toxicol Pharmacol.* 2007; 146: 60-78. DOI: 10.1016/j.cbpc.2006.05.007
4. Chen L, Li J, Zhu W et al. Skin and Gut Microbiome in Psoriasis: Gaining Insight Into the Pathophysiology of It and Finding Novel Therapeutic Strategies. *Front Microbiol.* 2020; 11: 589726. DOI: 10.3389/fmicb.2020.589726
5. Choi EW, Se MK, Woo EY et al. Exosomes from human adipose-derived stem cells promote proliferation and migration of skin fibroblasts. *Exp Dermatol.* 2018a. 27: 1170–1172. DOI: 10.1111/exd.13451
6. Choi EJ, Lee HG, Bae IH et al. Propionibacterium acnes-Derived Extracellular Vesicles Promote Acne-Like Phenotypes in Human Epidermis. *J Invest Dermatol.* 2018b; 138: 1371-1379. DOI: 10.1016/j.jid.2018.01.007
7. Choo WT, Teoh ML, Phang SM et al. Microalgae as Potential Anti-Inflammatory Natural Product Against Human Inflammatory Skin Diseases. *Front. Pharmacol.* 2020; 11: 1086. DOI: 10.3389/fphar.2020.01086
8. Deo P, ChowSH, Han ML. et al. Mitochondrial dysfunction caused by outer membrane vesicles from Gram-negative bacteria activates intrinsic apoptosis and inflammation. *Nat Microbiol.* 2020; 5: 1418–1427. DOI: 10.1038/s41564-020-0773-2
9. Díaz-Ley B, Cuevast J, Alonso-Castro L et al. Benefits of Plasma Rich in Growth Factors (PRGF) in Skin Photodamage: Clinical Response and Histological Assessment. *Dermatol Ther.* 2015; 28: 258–263. DOI: 10.1111/dth.12228
10. Dreier J, Sørensen JA, Brewer JR. Superresolution and Fluorescence Dynamics Evidence Reveal That Intact Liposomes Do Not Cross the Human Skin Barrier. *PLOS ONE,* 2016; 11: e0146514. DOI: 10.1371/journal.pone.0146514
11. Elnehrawy NY, Ibrahim ZA, Eltoukhy AM, Nagy HM. Assessment of the Efficacy and Safety of Single Platelet-Rich Plasma Injection on Different Types and Grades of Facial Wrinkles. *J Cosmet Dermatol.* 2017; 16: 103–111. DOI: 10.1111/jocd.12258
12. Erwin N, Serafim MF, He M. Enhancing the Cellular Production of Extracellular Vesicles for Developing Therapeutic Applications. *Pharm Res.* 2022; DOI: 10.1007/s11095-022-03420-w



13. Gangoda L, Boukouris S, Liem M et al. Extracellular vesicles including exosomes are mediators of signal transduction: Are they protective or pathogenic? *Proteomisc.* 2015; 15: 260-271. DOI: 10.1002/pmic.201400234
14. Grice EA, Kong HH, Conlan S et al. Topographical and temporal diversity of the human skin microbiome. *Science.* 2009; 324: 1190-1192. DOI: 10.1126/science.1171700
15. Hahm J, Kim J, Park J. Strategies to Enhance Extracellular Vesicle Production. *Tissue Eng Regen Med.* 2021; 18: 513-524. DOI: 10.1007/s13770-021-00364-x
16. Hersant B, SidAhmed-Mezi M, Aboud C, et al. Synergistic Effects of Autologous Platelet-Rich Plasma and Hyaluronic Acid Injections on Facial Skin Rejuvenation. *Aesthet Surg J.* 2021; 41: NP854–NP865. DOI: 10.1093/asj/sjab061
17. Jo H, Brito S, Kwak BM, Park S, Lee M-G, Bin B-H. Applications of Mesenchymal Stem Cells in Skin Regeneration and Rejuvenation. *Int J Mol Sci.* 2021; 22: 2410. DOI: 10.3390/ijms22052410
18. Kee LT, Ng CY, Al-Masawa ME et al. Extracellular Vesicles in Facial Aesthetics: A Review. *Int J Mol Sci.* 2022; 23: 6742. DOI: 10.3390/ijms2312674
19. Kelm RC, Ibrahim O. Utility of platelet-rich plasma in aesthetics. *Clinics in Dermatol.* 2022; 40: 19-28. DOI: 10.1016/j.clindermatol.2021.08.007
20. Kharaziha P, Ceder S, Li Q, Panaretakis T. Tumor cell-derived exosomes: A message in a bottle. *Biochim Biophys Acta.* 2012; 1826: 103-111. DOI: 10.1016/j.bbcan.2012.03.006
21. Kim HJ, Kim JJ, Myeong NR, Kim T, Kim D, An S, et al. Segregation of age-related skin microbiome characteristics by functionality. *Sci Rep.* 2019; 9: 16748. DOI: 10.1038/s41598-019-53266-3
22. Kolonics F, Szeifert V, Timár CI et al. The Functional Heterogeneity of Neutrophil-Derived Extracellular Vesicles Reflects the Status of the Parent Cell. *Cells.* 2020; 9: 2718. DOI: 10.3390/cells9122718
23. Laughlin RC, Alaniz RC. Outer membrane vesicles in service as protein shuttles, biotic defenders, and immunological doppelgängers. *Gut Microbes.* 2016; 7: 450-454. DOI: 10.1080/19490976.2016.1222345
24. Lemoine L, Dieckmann R, Al Dahouk S et al. Microbially competent 3D skin: a test system that reveals insight into host–microbe interactions and their potential toxicological impact. *Arch Toxicol.* 2020; 94: 3487–3502. DOI: 10.1007/s00204-020-02841-z
25. Li Y, Wang H, Wang J. Exosomes as a novel pathway for regulating development and diseases of the skin. *Biomed Rep.* 2018; 8:207–214. DOI: 10.3892/br.2018.1054
26. Martínez-Ruiz M, Martínez-González CA, Kim D-H, et al. Microalgae Bioactive Compounds to Topical Applications Products—A Review. *Molecules.* 2022; 27: 3512. DOI: 10.3390/molecules27113512
27. Mehryan P, Zartab H, Rajabi A et al. Assessment of Efficacy of Platelet-Rich Plasma (PRP) on Infraorbital Dark Circles and Crow's Feet Wrinkles. *J Cosmet Dermatol.* 2014; 13: 72–78. DOI: 10.1111/jocd.12072
28. Motta JP, Flannigan KL, Agbor TA et al. Hydrogen sulfide protects from colitis and restores intestinal microbiota biofilm and mucus production. *Inflamm Bowel Dis.* 2015; 21: 1006–17. DOI: 10.1097/MIB.0000000000000345
29. Nancarow-Lei, R.; Mafi, P.; Mafi, R.; Khan, W. A Systemic Review of Adult Mesenchymal Stem Cell Sources and Their Multilineage Differentiation Potential Relevant to Musculoskeletal Tissue Repair and Regeneration. *Curr Stem Cell Res Ther.* 2017; 12: 601–610. DOI: 10.2174/1574888X12666170608124303
30. Nurden AT, Nurden P, Sanchez M, et al. Platelets and wound healing. *Front Biosci.* 2008; 13: 3532–3548. DOI: 10.2741/2947
31. Paller AS, Kong HH, Seed P et al. The microbiome in patients with atopic dermatitis. *J Allergy Clin Immunol.* 2019; 143: 26-35. DOI: 10.1016/j.jaci.2018.11.015
32. Picciotto S, Barone ME, Fierli D et al. Isolation of extracellular vesicles from microalgae: towards the production of sustainable and natural nanocarriers of bioactive compounds. *Biomater Sci.* 2021; 9: 2917-2930. DOI: 10.1039/d0bm01696a
33. Qu F, Geng R, Liu Y, Zhu J. Advanced nanocarrier- and microneedle-based transdermal drug delivery strategies for skin diseases treatment. *Theranostics.* 2022; 12: 3372-3406. DOI: 10.7150/thno.69999
34. Rodríguez-Díaz C, Martín-Reyes F, Taminiau B, et al. The Metagenomic Composition and Effects of Fecal-Microbe-Derived Extracellular Vesicles on Intestinal Permeability Depend on the Patient's Disease. *Int. J. Mol. Sci.* 2023; 24: 4971. DOI: <https://doi.org/10.3390/ijms24054971>
35. Sansone C, Brunet C. Promises and Challenges of Microalgal Antioxidant Production. *Antioxidants (Basel).* 2019; 8:199. DOI: 10.3390/antiox8070199
36. Santos AC, Morais F, Simões A et al. Nanotechnology for the development of new cosmetic formulations. *Expert Opin. Drug Deliv.* 2019; 16: 313–330. DOI: 10.1080/17425247.2019.1585426
37. Sartorio MG, Pardue EJ, Feldman MF, Haurat MF. Bacterial Outer Membrane Vesicles: From Discovery to Applications. *Annu Rev Microbiol.* 2021; 75: 609-630. DOI:10.1146/annurev-micro-052821-031444
38. Sclafani AP. Platelet-Rich Fibrin Matrix for Improvement of Deep Nasolabial Folds. *J Cosmet Dermatol.* 2010; 9: 66–71. DOI: 10.1111/j.1473-2165.2010.00486.x
39. Schommer NN, Gallo RL. Structure and function of the human skin microbiome. *Trends Microbiol.* 2013; 21: 660-668. DOI: 10.1016/j.tim.2013.10.001



40. Schüler LM, Santos T, Pereira H et al. Improved production of lutein and β -carotene by thermal and light intensity upshifts in the marine microalga *Tetraselmis* sp. CTP4. *Algal Research*. 2020; 45: 101732. DOI: <https://doi.org/10.1016/j.algal.2019.101732>
41. Sharma D, Kober MM, Bowe WP. Anti-Aging Effects of Probiotics. *J Drugs Dermatol*. 2016; 15: 9-12
42. Sirithanabadeekul P, Dannarongchai A, Suwanchinda A. Platelet-rich plasma treatment for melasma: a pilot study. *J Cosmet Dermatol*. 2020; 19: 1321-1327. DOI: 10.1111/jocd.13157
43. Song L, Webb NE, Song Y, Tuan RS. Identification and functional analysis of candidate genes regulating mesenchymal stem cell self-renewal and multipotency. *Stem Cells*. 2006; 24: 1707-1718. DOI: 10.1634/stemcells.2005-0604
44. Troha K, Vozel D, Arko M, et al. Autologous Platelet and Extracellular Vesicle-Rich Plasma as Therapeutic Fluid: A Review. *Int. J. Mol. Sci*. 2023; 24: 3420. DOI: 10.3390/ijms24043420
45. Villard A, Boursier J, Andriantsitohaina R. Microbiota-derived extracellular vesicles and metabolic syndrome. *Acta Physiol (Oxf)*. 2021; 231: e13600. DOI: 10.1111/apha.13600
46. Wiklander OPB, Brennan MA, Lotvall J, et al. Advances in therapeutic applications of extracellular vesicles. *Sci. Transl. Med*. 2019; 11: eaav8521. DOI: 10.1126/scitranslmed.aav8521
47. Zavec AB, Kralj - Igljč V, Brinc M et al. Extracellular vesicles concentration is a promising and important parameter for industrial bioprocess monitoring. *Biotechnol J*. 2016; 11: 603-609. DOI: 10.1002/biot.201500049
48. Zhao B, Zhang Y, Han S, et al. Exosomes derived from human amniotic epithelial cells accelerate wound healing and inhibit scar formation. *J Mol Histol*. 2017; 4: 121-132. DOI: 10.1007/s10735-017-9711-x
49. Yáñez-Mó M, Siljander PRM, Andreu Z, Bedina Zavec A et al. Biological properties of extracellular vesicles and their physiological functions. *J Extracell Vesicles*. 2015; 4: 27066. DOI: 10.3402/jev.v4.27066
50. Yarkent C, Gürlek C, Oncel SS. Potential of microalgal compounds in trending natural cosmetics: A review, *Sustainable Chemistry and Pharmacy*. 2020; 17: 100304. DOI: 10.1016/j.scp.2020.100304.
51. Yerneni SS, Yalcintas EP, Smith JD et al. Skin-targeted delivery of extracellular vesicle-encapsulated curcumin using dissolvable microneedle arrays. *Acta Biomater*. 2022; 149: 198-212. DOI: 10.1016/j.actbio.2022.06.046.

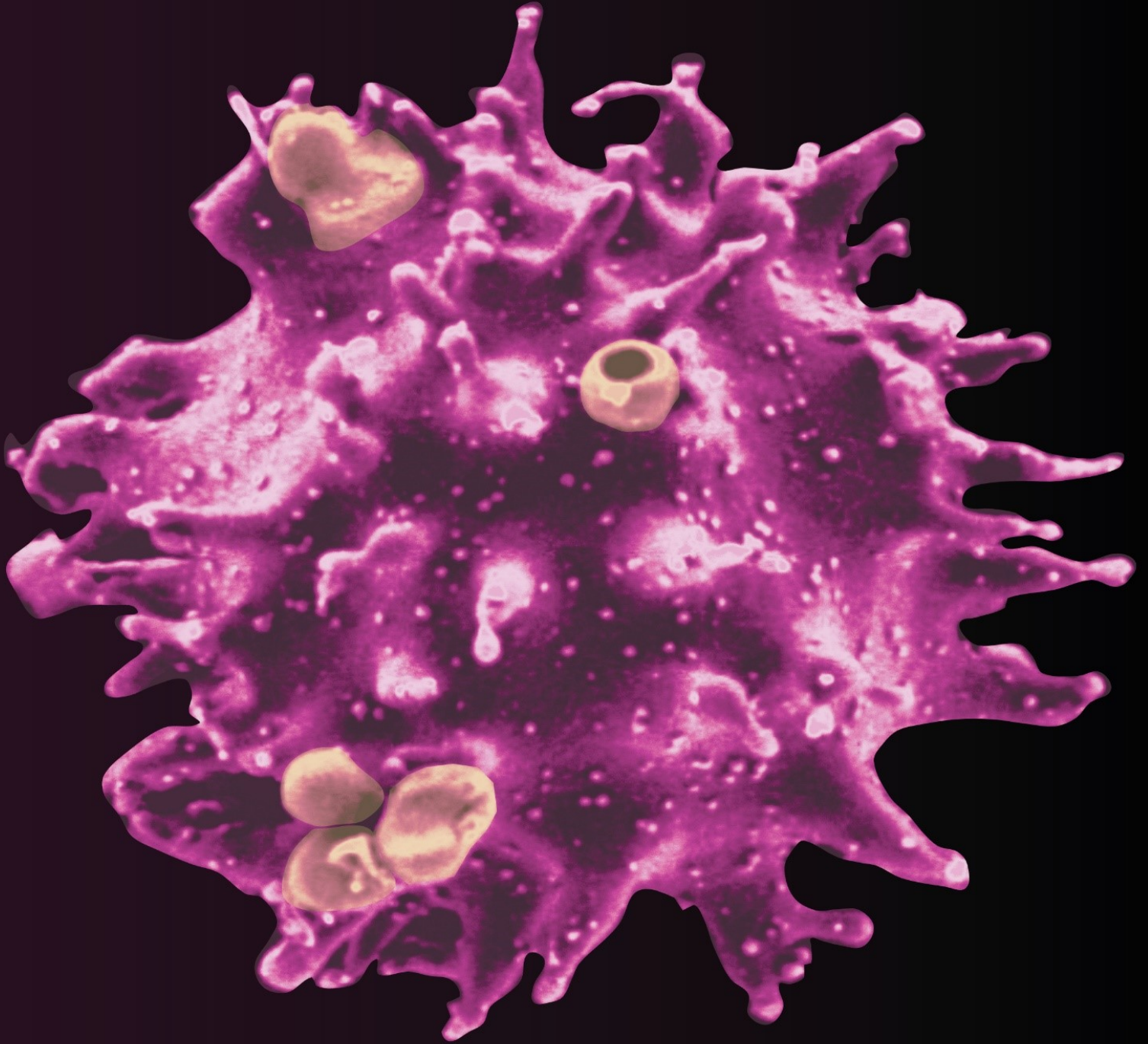

Scientific contribution

Testing Market Efficiency in Emerging Markets' Stock Indices with Runs Tests

Smerkolj Nik ¹, Jeran Marko^{2,*}

¹ École des Hautes Études Commerciales de Paris, HEC Paris, Paris, France

² Department of Inorganic Chemistry and Technology, "Jožef Stefan" Institute, Ljubljana, Slovenia

* Correspondence: M.J. marko.jeran@ijs.si

Citation: Smerkolj N, Jeran M. Testing Market Efficiency in Emerging Markets' Stock Indices with Runs Tests.

Proceedings of Socratic Lectures. 2023, 8; 125-129.

<https://doi.org/10.55295/PSL.2023.II17>

Publisher's Note: UL ZF stays neutral with regard to jurisdictional claims in published maps and institutional affiliations.



Copyright: © 2023 by the authors. Submitted for possible open access publication under the terms and conditions of the Creative Commons Attribution (CC BY) license (<https://creativecommons.org/licenses/by/4.0/>).

Abstract:

According to the efficient market hypothesis (EMH), the prices of securities reflect all the available information on the market. Efficient markets have an important consequence – it is not possible for an investor to consistently outperform the market by using information that is not already reflected in the prices of securities. No matter how much resources one deploys into security analysis, no excess return can be made, which means that investors seeking higher returns must bear higher risk given the risk-return trade-off. Inefficient markets, on the other hand, offer investors opportunities for higher returns at the same risk profile. In this scientific contribution, we test seven emerging markets' stock indices for a weak form of market efficiency. Numerous previous research indicates that emerging markets are not fully efficient and that prices on their stock markets do not follow a random walk. We performed runs tests on weekly and monthly returns of stock indices and found statistically significant results in three indices for weekly and three indices for monthly returns, which indicates that these indices violate weak form of market efficiency. We found insignificant results, which indicate efficient markets, only for weekly and monthly returns on the Indian BSE Sensex 30 Index. Thus we come to similar conclusions as other authors that emerging markets persist to violate weak form of market efficiency and remain an attractive opportunity for investors seeking to exploit inefficiencies.

Keywords: Market efficiency; Efficient market hypothesis; Random walk; Emerging markets; Stock Exchange Index; Runs test



1. Introduction

1.1. Market efficiency

Market efficiency corresponds to the information efficiency of the market, that is the degree of information reflected in the market price of financial security. The efficient market hypothesis (EMH) states that the prices of securities reflect all information available (Busse and Green, 2002). New information that causes security prices to change is unpredictable because predictable future information is captured in the prices today. When new information arrives on the market, the security price will either increase or decrease through a random process. This is the so-called random walk hypothesis, under which stock price movements are random and unpredictable (Aktan et al., 2017). There are three forms of market efficiency – weak, semi-strong and strong form. According to the weak form of market efficiency security's price captures all available past information, which conveys that we cannot predict price changes based on the past prices of security (Fama, 1970). In practice, this means that with technical analysis of past security prices, we cannot achieve returns above the market. Under a semi-strong form of efficiency, all publicly available information is captured and reflected in the price of a security, which means that even with a fundamental analysis of security one cannot achieve returns superior to the market. The most rigorous form of market efficiency is the strong form, which states that securities' prices reflect all past price information, all publicly available information and also all private (often called insider) information. If a market is efficient in strong form, there is no possibility for abnormal returns for investors and we can see that under the strong form, we satisfy also the semi-strong and weak form of market efficiency (Aktan et al., 2017).

Efficient markets are very important in the financial world, as no matter how much resources one deploys into security analysis, no excess return can be made (given the assumption of strong form efficiency). This means that investors seeking higher returns must bear higher risk given the risk-return trade-off. Efficient markets also mean that well-educated and experienced investors cannot make any higher returns than beginners for the same level of risk exposure. If markets are inefficient, investors can benefit from the under- or overvaluation of the security and make higher returns for the same risk profile. Numerous research shows that prices on stock markets of emerging economies don't follow a random walk (Aktan et al. 2017), which means that the security's price will deviate from the fair value. This is only one of the reasons why emerging markets remain in high popularity among investors.

Emerging markets are defined as markets in development, which do not meet all the requirements of a fully developed market (MSCI, 2022). Definitions vary broadly and so do the countries that are included in the emerging market indices, however, Brazil, China, India, Indonesia, Russia, Saudi Arabia, South Korea, Taiwan and Turkey are generally included. In the MSCI Emerging Markets Index, there are currently 24 countries of which 5 are from the Americas region, 11 from EMEA and 8 from Asia.

1.2. Methodology to test market efficiency

There are different statistical tests which help researchers and investors determine the presence of weak form market efficiency. To test broader, but still particular, stock market efficiency we use stock market indices, which consolidate changes in prices of individual securities listed on the stock exchange and included in the stock index. Not all public companies are included in a particular index, however, such indices provide information on overall movements in the stock market and are universally used in the financial world. Each statistical analysis begins by calculating the returns of a particular index since we are analysing price changes and not prices per se. There are two straightforward methods for testing weak form market efficiency, autocorrelation test and runs test – the usage of which we demonstrate in the next paragraph. With the autocorrelation test, we determine whether returns are influenced by their own lagged values over time. Insignificant autocorrelation for all selected lags indicates efficient markets (Aktan et al. 2017).

2. Methods

To demonstrate the testing of the weak form efficient market hypothesis we will use runs tests on weekly and monthly returns of seven emerging market indices. We have extracted prices from the base date for each stock index from Refinitiv software and calculated weekly and monthly returns to exclude noises on daily basis. Selected indices include Shanghai Stock Exchange Composite Index (SSE, China), S&P Bombay Stock Exchange Sensitive Index (BSE Sensex, India), Indice de Precios y Cotizaciones Index (IPC Bolsa, Mexico), Russian Trading System Index (RTS, Russia), Korea Composite Stock Price Index (KOSPI, South Korea), Taiwan Capitalization Weighted Stock Index (TAIEX, Taiwan) and Borsa Istanbul National 100 Index (BIST 100, Turkey).

Runs test checks the randomness of runs in a sequence of returns of an index. It is an especially useful test since it does not require the returns to be normally distributed (Sharma et al. 2015). We analysed the occurrence of the same events (a sequence of positive or negative returns) that are separated by the occurrence of a sequence of returns of the opposite sign (Hawaldar 2017). The mean and variance are calculated as shown in **Equation (2)** (mean) and **Equation (3)** (variance), where n^+ is the number of positive returns in the data set, n^- is the number of negative returns in the data set and N :

$$N = n^+ + n^- \quad (1)$$

$$\mu = \frac{2 \cdot n^+ \cdot n^-}{(n^+ + n^-)^2} \quad (2)$$

$$\sigma^2 = \frac{2 \cdot n^+ \cdot n^- \cdot (2 \cdot n^+ \cdot n^- - n^+ - n^-)}{(n^+ + n^-)^2 \cdot (n^+ + n^- - 1)} = \frac{2 \cdot n^+ \cdot n^- \cdot (2 \cdot n^+ \cdot n^- - N)}{N^2 \cdot (N - 1)} \quad (3)$$

Standard z-statistics is used to conduct the runs test. A statistically significant test (p -value $\leq \alpha$) indicates that returns are *non*-random and thus violate a weak form of market efficiency (Hawaldar et al. 2017). Before carrying out the tests we form a null and alternative hypothesis.

H₀: Sequence of index returns is random.

H₁: Sequence of index returns is not random.

3. Results

We analysed 14 data sets (seven stock indices on a weekly and monthly basis) from their base date. The highest average weekly return of 0.80% was achieved on the Turkish BIST National 100 Index, while the lowest average weekly return of 0.20% was achieved on Korean SE Composite Index. Turkish BIST National 100 Index recorded also the highest weekly standard deviation (6.0%) on a weekly level, while Korean SE Composite Index recorded the lowest one (3.3%). Similarly, the Turkish BIST National 100 Index recorded the highest average monthly return and the highest monthly standard deviation, while Korean SE Composite Index recorded the lowest average monthly return and the lowest monthly standard deviation. This shows that based on weekly and monthly historical data, higher risk brought higher returns. We used Microsoft Excel (Version 2212) to calculate descriptive statistics, which are provided in **Table 1**.



Table 1. Descriptive statistics for weekly and monthly returns of selected indices.

Index	Mean	Min.	Max.	Std. dev.	Skewness	Kurtosis
<i>Panel A: weekly returns</i>						
SSE	0.0031	-0.2285	0.9339	0.0511	4.5510	74.9881
BSE Sensex 30	0.0034	-0.2061	0.3940	0.0366	0.6211	8.5551
IPC Bolsa	0.0041	-0.1974	0.3066	0.0378	0.5531	7.3161
RTS	0.0033	-0.3266	0.4076	0.0584	0.1006	5.8113
KOSPI	0.0020	-0.1746	0.1994	0.0335	0.0274	4.0350
TAIEX	0.0025	-0.2158	0.2159	0.0375	-0.1696	3.4175
BIST National 100	0.0080	-0.3082	0.4155	0.0603	0.4438	3.8776
<i>Panel B: monthly returns</i>						
SSE	0.0155	-0.3200	1.5619	0.1360	5.0191	49.5797
BSE Sensex 30	0.0148	-0.2856	0.5280	0.0769	0.7473	4.7088
IPC Bolsa	0.0179	-0.2522	0.4689	0.0781	0.7815	4.9043
RTS	0.0160	-0.5492	0.5454	0.1292	-0.0331	2.8593
KOSPI	0.0088	-0.2725	0.4837	0.0713	0.6957	4.3174
TAIEX	0.0119	-0.3836	0.4360	0.0925	0.5786	3.8935
BIST National 100	0.0364	-0.5048	1.0000	0.1471	1.8102	8.2609

Table 2 provides Z-values and corresponding *p*-values for weekly and monthly returns of selected indices. We used Microsoft Excel (Version 2212) to calculate aforementioned statistics and corresponding *p*-values. There are three statistically significant runs tests on weekly returns (Chinese, Russian and Taiwanese stock indices), which indicates the presence of market inefficiency. Statistically insignificant results indicate the presence of a weak form of market efficiency. When performing runs tests on monthly returns we found three results to be statistically significant (Mexican, South Korean and Turkish stock indices).

Table 2. Results of runs tests.

	<i>Weekly Returns</i>		<i>Monthly Returns</i>	
	<i>Z value</i>	<i>p-value</i>	<i>Z value</i>	<i>p-value</i>
SSE	-2.010	0.044**	-1.353	0.176
BSE Sensex 30	0.597	0.550	-0.473	0.636
IPC Bolsa	0.696	0.486	-2.086	0.037*
RTS	-3.170	0.002***	-1.195	0.232
KOSPI	-1.118	0.263	-1.994	0.046*
TAIEX	-4.014	0.000***	-1.070	0.285
BIST National 100	-0.659	0.510	-2.051	0.040*

*The stars indicate significance at 1% (***), 5% (**) and 10% (*)*



4. Conclusions

Based on the results of the runs test we can conclude that certain previously mentioned emerging markets' stock indices violate weak form of market efficiency. The only stock index with statistically insignificant results both for weekly and monthly returns was the Indian BSE Sensex 30 Index.

With runs tests, we have proven that emerging markets are not completely efficient, which might partially explain institutional investors' interest in those markets while searching for higher returns and arbitrage opportunities. Violation of the Efficient market hypothesis suggests that it is possible for an investor to consistently outperform the market because information and collective knowledge of market participants is not fully reflected in the price of a security.

Conflicts of Interest: The authors declare no conflict of interest.

References

1. Aktan C, Sahin EE, Kucukkaplan I, Testing the information efficiency in emerging markets. In: Kucukkocaoglu G, Gokten S, editors. Financial management from an emerging market perspective. London, United Kingdom, IntechOpen. 2017; pp. 49–67. DOI: 10.5772/intechopen.70369
2. Busse JA, Green TC. Market efficiency in real time. *J Financ Econ*. 2002; 65: 415–437. DOI: 10.1016/S0304-405X(02)00148-4
3. Fama EF. Efficient capital markets: A review of theory and empirical work. *J. Finance*. 1970; 25: 383–417. DOI: 10.2307/2325486
4. Hawaldar IT, Rohit B, Pinto P. Testing of weak form of efficient market hypothesis: evidence from the Bahrain Bourse. *Invest Manag Financ Innov*. 2017; 14: 376–385. DOI: 10.21511/imfi.14(2-2).2017.09
5. MSCI (2022), Market Classification Framework. Accessed 2.1.2023. Available from: https://www.msci.com/documents/1296102/1330218/MSCI_Market_Classification_Framework.pdf
6. Sharma A, Thaker K. Market efficiency in developed and emerging markets. *Afro-Asian J Finance Account*. 2015; 5: 311–333. DOI: 10.1504/AAJFA.2015.073470





Invited lecture/Scientific contribution

The Story about One Island and Four Cities.

The Socio-Economic Soft Matter Model - Based Report.

Rzoska Agata Angelika^{1*}, Drozd-Rzoska Aleksandra^{2*}

¹University of Economics, Dept. of Marketing, Katowice, Poland

²Institute of High Pressure Physics Polish Academy of Sciences, Warsaw, Poland

*Correspondence: A.A. Rzoska; agata.rzoska@edu.uekat.pl; A. Drozd-Rzoska; arzoska@unipress.waw.pl

Citation: Rzoska AA, Drozd-Rzoska A. The Story about One Island and Four Cities. The Socio-Economic Soft Matter Model - Based Report. Proceedings of Socratic Lectures. 2023, 8; 131-147. <https://doi.org/10.55295/PSL.2023.II18>

Publisher's Note: UL ZF stays neutral with regard to jurisdictional claims in published maps and institutional affiliations.

Abstract:

The report discusses the emergence of the Socio-Economic Soft Matter as the consequence of interactions between physics and economy, since the onset of modern times. First, using soft matter science tools, demographic changes since the Industrial Revolution times onset are tested. It is supported by innovative derivative-sensitive and distortions-sensitive analytic tools. All these revealed for population changes the Weibull-type powered exponential description, with the crossover to the lesser rising pattern emerging after the year 1970. Subsequently, population changes are tested for the Rapa Nui (Easter) Island model case and for four selected model cities where the rise and decay phases have occurred. They are Detroit and Cleveland in USA and Łódź (Lodz, the former textile industry center), and Bytom (the former coal mining center) in Poland. The analysis shows universal scaling patterns for population changes, coupled to the socio-economic background impact, revealing also the long-lasting determinism. Finally, sources of obtained universal behavior are discussed in the frame of the Socio-Economic Soft Matter concept.

Keywords: Demography; Socio-economy; Soft Matter; Weibull distribution; Rapa Nui; Post-industrial cities



Copyright: © 2023 by the authors. Submitted for possible open access publication under the terms and conditions of the Creative Commons Attribution (CC BY) license (<https://creativecommons.org/licenses/by/4.0/>).



1. Introduction

Nicolai Copernicus, Galileo Galilei, Isaac Newton, created the Modern Scientific Method. It is related to the non-speculative approach, with the experimental cross-verification of heuristic and thought concepts and the verbalization of results using a mathematical apparatus. It isn't easy to outline one of these giants, but Isaac Newton has to be appreciated for the Modern Science path's final shaping (Westfall, 1994). It led to unprecedented progress associated with new fundamental knowledge and innovations. The world entered a qualitatively new era of innovation-driven development, removing many problems that have plagued people for millennia. It is the onset of the Industrial Revolutions times (Groumpos, 2021).

Isaac Newton is mainly known for two monographs defining the basics of Mechanics (dynamics), Gravity, and Optics. He introduced the concepts of derivatives, differential equations, and integral analysis for a coherent and in-depth description. His indication that seemingly separate phenomena may have a common 'universal' source can be regarded as of particular importance. It was beyond any expectation at that times that a falling apple and the motion of planets and comets could reflect the same universal law of gravity, concluded in a simple, functional equation (Westfall, 1994).

Adam Smith, the 'father' of modern economics, was so overwhelmed by the concept of 'all-embracing universality' that he began to look for such phenomena in social and political economy-related phenomena (Smith, 1776, 2009). It is worth noting that Newton was also directly involved in such problems. Recognizing the great merits of his mind, Newton was nominated the Royal Mint head. His main task was preventing (dramatic) falls in currency value. Newton quickly realized that it was mainly due to a (very) physical action of forgers - scraping the edges of the coins, which reduced their weight. Newton solved the problem by developing an innovative hard metal alloy for coins and a serrated edge pattern for coins. Thanks to a multidisciplinary innovation combining physics, materials engineering, economics, and behavioral observations, Newton solved the grand socio-economic problem of the United Kingdom. This innovation is still in use (Westfall, 1994).

This report attempts to apply some basic concepts of physics, particularly soft matter physics, to discuss socio-economic and demographic model-system peculiarities and include universalistic ideas hidden behind them. To validate the application of physics to such issues, let's look at Newton's famous laws of motion from a socio-economic point of view:

1. When no force is acting on the body, or when these forces balance each other, it is at rest or moves at a constant speed along a straight line. Does it not also mean proportional, 'linear' development of the company, city, and even the state when positive and negative external factors balance each other?
2. The motion is related to the force F acting on a body with mass m , the measure of its inertia: $F = am$, where $a = const$ is the acceleration. In socio-economics, a parallel could be drawn by efforts invested into the activities of a large company with enormous structural inertia, compared to the rapid pro-market returns of medium and small companies.
3. There is no single force. Any action is accompanied by a reaction. The number of analogies in economics and everyday life is evident in the given case.

Three decades ago, Pierre Gilles de Gennes was awarded the Nobel Prize in Physics (1991) for another grand unification. He introduced the Soft Matter (SM) category linking many materials common in our surroundings. At first, it was related to polymers, liquid crystals, micellar systems, critical liquid,... (de Gennes et Badoz, 1996). Now, within Soft Matter also bio-systems, including colonies of bacteria and viruses, or food as the very complex soft matter case are considered (Drozd-Rzoska et al., 2002; Rzoska et al., 2011; Drozd-Rzoska et al., 2005a; Drozd-Rzoska et al., 2005b; Drozd-Rzoska, 2005; Drozd-Rzoska et al.,



2006; Drozd-Rzoska et al., 2010). For the latter, one can recall popular products from milk, yogurt, mayonnaise, ketchup... to pastes, cakes, and meat (Mezzenga et al., 2005). The Soft Matter concept has also been extended to topological (Serra et al., 2020) and quantum (Thedford et al., 2022) systems, offering new insight into fundamental Space properties.

What does Soft Matter mean? (de Gennes et Badoz, 1996). What can connect such apparently distinct systems? Only two common features are essential for universal characterizations and scaling patterns linking apparently distinct Soft Matter systems:

- A. the dominance of collective, mesoscale 'structures', mainly correlated assemblies of atoms, molecules, or any other type of entities building a system/material.
- B. extreme sensitivity to exo- and endo-genic impacts, which in fact, is the consequence of point (A).

In 2007, *The Guardian* magazine published a farewell to Pierre Gilles de Gennes in the following words (Goodby and Gray, 2007):

"...Newton of our time has died aged 74. He was awarded Nobel Prize, the Lorentz medal and Wolf prize for "discovering that methods developed for studying order phenomena in simple systems can be generalized to more complex forms of matter."

In the recent work, the authors of this report put forward the thesis that one can consider the Socio-Economic Soft Matter due to the exemplary fulfillment of the above (A, B) general conditions. The global population $P(t)$ was chosen as a model system, and its evolution from the beginning of the Holocene / Anthropocene epoque, with the onset at $t_{ref.} = 12000BC$ was examined using Soft Matter tools (Rzoska, 2016; Rzoska and Drozd-Rzoska, 2022). The following scaling pattern for the population changes was revealed:

$$P(t) = p_0 \exp\left(\pm \frac{\Delta t}{\tau(t)}\right)^\phi \quad (1)$$

where $P(t)$ denotes population changes as the function of time, p_0 is for the prefactor, $\tau(t)$ is the relaxation time constant, ϕ is the power exponent; $\Delta t = t - t_{ref.}$, and $t_{ref.}$ is the reference (onset) time; \pm signs are related to the rise and decay process, respectively.

In Soft Matter systems, the exponent $\phi = 1$ indicates that the system is governed by a single relaxation time for dynamic processes or modes. For $0 < \phi < 1$, Expression (1) is named as the stretched relaxation relation, indicating a distribution of relaxation time (processes) (Drozd-Rzoska and Rzoska, 2011). In physicochemical systems $\tau(t) = \tau = const$ is assumed. Values related to $\phi > 1$ are for the 'compressed' relaxation processes, which are hardly observed in physico-chemical systems. The exception is $\phi = 2$, which is equivalent to the normal (Gaussian) distribution (Rinne, 2008) of probability for different random allowed states of the system. It is notable that a similar expression as the one in Equation (1) resembles one of Weibull's functions which are used to describe general probability distribution analysis for dynamic processes via different relaxation channels (Rinne, 2008; Rzoska and Drozd-Rzoska, 2011). This analysis is often implemented in various technological applications (Rinne, 2008), as well as in medicine Feroze et al, 2022), and microbiology (Buzrul, 2022). For the simplest case, i.e. for $\phi = 1$ in Equation (1), data analysis can be concluded using the following linear dependence:

$$\ln P(\Delta t) = \ln p_0 - \frac{1}{\tau} \Delta t \quad (2)$$

The single-relaxation time dynamics, related to $\phi = 1$ in Equation (1), can be validated by the linear behavior in the plot defined by Equation (2). Following Equations. (1) and (2) $P(t = 0)/P(t = \tau) = e \approx 2.7$, i.e., the relaxation time τ is related to $1/e \approx 0.3678$ decrease of $P(t)$, with reference to the initial value. The convenient metric can be the parameter $\tau_{1/2} = \tau \times \ln 2$ describing the time required for 50% change in $P(t)$, which can be obtained by considering the relationship between logarithmic functions with different bases: $\ln P(t) = \log_e P(t)$ and $\log_{10} P(t)$. The 'powered' Equation (1) with the arbitrary



value of the exponent $\phi \neq 1$ can be related to $(1/e)^{1/\phi}$ decay (Rzoska et al., 1997; Rzoska and Drozd-Rzoska, 2022).

The nonlinear fitting is used for describing ‘experimental’ data by Equation (1) with the powered exponential function related to the exponent $\phi \neq 1$. Numerous practical implementations in soft matter systems showed that the direct nonlinear fitting using Equation (2) leads to surprisingly large errors for derived parameters. This basic problem can be avoided when considering the derivative of Equation (1) (Rzoska and Drozd-Rzoska, 2022):

$$\frac{d(\ln P(t))}{dt} = \frac{1}{P(t)} \frac{dP(t)}{dt} = \pm \frac{\phi}{\tau} \Delta t^{\phi-1} \quad . \quad (3)$$

The linearization of Equation (3) gives the following dependence (Rzoska & Drozd-Rzoska, 2022):

$$\log_{10} \left| \frac{d(\ln P(t))}{dt} \right| = \log_{10}(\phi) + (\phi - 1) \log_{10} \Delta t = a + s \log_{10} \Delta t \quad (4)$$

where parameters $a = \log_{10}(\phi/\tau) = \text{const}$, and $s = \phi - 1$.

The presentation of transformed $P(t)$ data via the plot $\log_{10}[d \ln P(t)/dt] \log_{10} \Delta t$ yields a linear behavior with the slope $s = \phi - 1$. The domain where Equation (1) can be applied is also indicated. By using the linearized analysis via Equation (4), one can reveal regions governed by different values of the exponent ϕ , and avoid the nonlinear fitting required for the direct analysis via Equation (1).

Recalling the discussion regarding the human population evolution, which is the key topic of the given report, the most significant model was introduced by Malthus (Malthus, 1803; Malthus and Stimson, 2018), who also declared the inspiration from Isaac Newton’s legacy. They assumed that the constant rate of population changes and applied the derivative analytic tool introduced by Newton. It is called the Malthus model relation (Malthus and Stimson, 2018; Weil and Wilde, 2010; Kaack and Katul, 2013):

$$\frac{dP(t)}{dt} \rightarrow (\Delta t \rightarrow 0) \rightarrow \frac{dP(t)}{dt} = rP \quad \Rightarrow \quad P(t) = p_0 \exp(rt) \quad (5)$$

where $r = r(t) = \text{const}$ is the Malthus rate coefficient.

Equation (5) correlates with ‘powered’ Equation (1) for $\phi = 1$ and $t_{ref.} = 0$.

Malthus (Malthus, 1803; Malthus and Stimson, 2018), confronted the exponential population rise suggested by Equation (5) with the presumably linear increase of food resources expected in 19th century. The inevitable intersection of the trends of changes in the population and the number of resources indicated the unavoidable lack of the latter and, consequently, the certainty of famine and social disorder.

In the mid of 19th century, Velhulst supplemented the Malthus model focusing on the population growth in restricted resource conditions leading to the rise of the population and its subsequent stabilization. Such a situation can be functionalized as follows (Velhulst, (1847) 2022):

$$\frac{dP(t)}{dt} = rP \left(1 + \frac{P(t)}{K} \right) \Rightarrow P(t) = \frac{K}{1 + \exp(-rt)(K - p_0)/p_0} = K \left[1 + \exp(-rt) \frac{K - p_0}{p_0} \right]^{-1} \quad (6)$$

where K is the constant characterizing the number of available resources.

The third type of the Malthus-type models is related to the function correlated with Equation (1), introduced as the heuristic most straightforward extension of the basic Malthus relation (Equation (5)) (Golosovsky, 2009 and refs. therein):

$$P(t) = p_0 \exp(rt^\phi) \quad . \quad (7)$$



It is applied via non-linear fit, generally in an arbitrarily selected time domain, which is always associated with large errors of derived parameters. The Weibull model function (Rinne, 2008; Golosovsky, 2009; Golosovsky, 2010) is often cited as a heuristic justification. The generalized Weibull-type equation (Equation (1)) (Rinne, 2008), supported by the distortions-sensitive and derivative-based analysis defined by Equation (4) was used to get new insight into the global population growth. It covers the entire period from the Holocene epoch onset.

Figure 1 presents the resume of these results, focused on the period after 1800, which covers the interest of the given report (Rzoska and Drozd-Rzoska, 2022). The result presented in **Figure 1** shows the non-monotonous pattern of global population rise based on Equation (1), governed by changes in the value of the exponent. Notable are periods where the increase of the global population slowed down, for instance, associated with World Wars I and II (WWI and WWII). Notable that for the latter, such trend started near 1930, which can be linked to the Grand Economic Depression, and terminated at 1948. The global population pattern changed from a fast to a slow rise near the year 1970. Is it the impact of ‘cultural revolts’ in 1968 (Gildea et al., 2013) and its consequences?

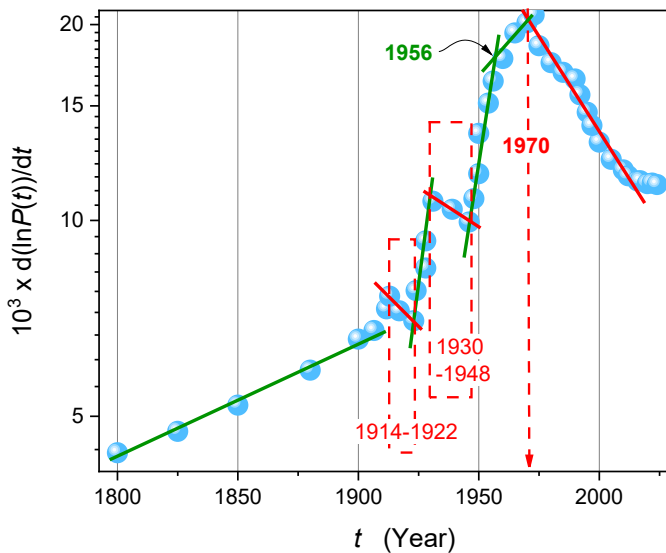

Figure 1: The plot showing the evolution of the World population using the Weibull-type Equation (1) and the distortions-sensitive analysis of its applicability (indicated by linear domain) via Equation (4). Slopes of lines are coupled to the power exponent ϕ in the Weibull-type Equation (1): slope of a line = $s = \phi - 1$. The behavior described by $s > 0$ (green lines) stands for the ‘strong’ rising rate of the population. The behavior described by $s < 0$ (red lines) stands for a significant decrease in the rising rate of the population. The crossover $s > 0 \rightarrow s < 0$ indicates the inflection between the mentioned trends. Characteristic years related to such changes are indicated. From (Rzoska and Drozd-Rzoska, 2022).

The Global Population exhibits the feature preferably expected for physical models – isolation from disturbing external factors, or at least their control. This work implements the concept of socio-economic Soft Matter for selected, characteristic, smaller-scale human populations, where the ‘isolation’ seems to be difficult, if possible at all.

Population changes in a size-restricted territory have to be inherently sensitive to internal factors, such as political and social conditions and available ‘attractive’ resources from food to energy. Such factors can also be non-material, as shown below. Notwithstanding, universal model-patterns also emerge in such apparently disturbed systems in the sub-global scale.

The discussion of this report starts from the Rapa-Nui (Easter Island case), which can be considered the canonic model for the development of ‘small’, isolated human populations.



2. Population Evolution : Microbiology parallel and the Rapa Nui (Easter Island) case

In the first centuries of the 1st Millennium, one of human history most significant exploration adventures occurred. Polynesians started grand oceanic travels, leading to the settlement of islands in the enormous area of the Pacific Ocean. The audacity and success of these efforts were and remain unprecedented. The expedition occurred on small but nautically perfect boats - catamarans and trimarans ensuring excellent journey stability. The exploration and settlement expeditions set off to other islands thousands of kilometers away without knowing whether they existed at journey terminals (O'Leary, 2021)

The enormous knowledge acquired at that time also supported the success of Captain James Cook grand expedition on the Endeavor ship, guided by Polynesian navigator Tupaya. The farthest island reached by explorers was Rapa Nui island, which European explorer Admiral Jacob Roggeveen called Easter Island in honor of his arrival there on Easter Sunday, April 5th, 1722. At that time, it was inhabited by 2 - 3 thousand people. Later studies showed that in the 16th and 17th centuries, the population of Rapa Nui was as high as 10-15,000 inhabitants. The next visit of Europeans was also of a research nature: in 1770, the expedition of Captain Felipe Gonzales de Ahedo, on the order of the viceroy of Peru, explored the island for 5 days (O'Leary, 2012).

In 1774, Captain James Cook visited the island during the grand Endeavor ship expedition. The visit resulted in excellent maps, descriptions of nature, comments regarding inhabitants, and communication on 'monumental' Moai statues on the coast. Captain Cook estimated the population between 700 and 200 inhabitants, with the latter being more likely. Between 1722 and 1770 on Rapa Nui, the final stage of the conflict between two existing clans known as 'short-ears' and 'long-ears' took place. It led to the disappearance of the 'long-ears' clan so completely that even no reliable genetic material remained. The remaining verbal tradition of the story on Rapa Nui indicates that the 'long-ears' could be the ruling clan in the Island (O'Leary, 2021).

A special feature of the development of the human population on Rapa Nui, associated with the formation of an extraordinary civilization with exceptional achievements, was operating in conditions of isolation from the outside world, both from other Pacific islands and mainland South America. The settlement of Rapa Nui is associated with the last phase of the great oceanic expansion of the Polynesians. Shortly afterward, climatic conditions deteriorated periodically, affecting the limitation of expeditions on small and relatively fragile boats. In a small area of Rapa Nui, there was also rapid deforestation, especially the disappearance of palm trees. It meant there was no boats for grand ocean voyages and even fishing in the ocean surrounding Rapa Nui ceased to be possible. The inhabitants were cut off from the world's richest fish and food resources in the surrounding ocean. Notwithstanding, there have been indications that residents have developed 'ecological' gardens inside the island, largely solving the resource problem. Rapa Nui's population has grown to about ~10,000+ inhabitants (Hunt and Lipo, 2012; Lima et al., 2020; O'Leary, 2021). However, from the mid of the 16th century, the global cooling of the climate, referred to as the Little Ice Age, took place. In Europe, its impressive manifestation was the winter freezing of the Baltic Sea, and traveled from Poland to Sweden using ice as the solid way.

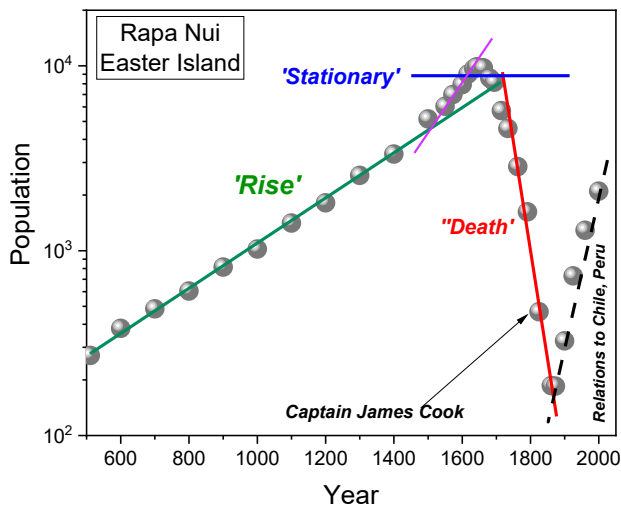

Figure 2: Changes of Easter Island (Rapa Nui) population since the hypothetical settlement till now. Based on data (O’Leary, 2021; Stevenson et al., 2006). The linear behavior is related to the Malthus model evolution, which is related to the exponent $\phi = 1$.

On Rapa Nui, it is a time of enormous intensification of the construction of increasingly monumental Moai sculptures - carved out of the volcanic rocks inside the island and transported on wood logs to the coast (O’Leary, 2021). Such activities had to absorb the relatively small population totally and also led to the final deforestation. It can be assumed that it was a kind of mystical rescue related to the growing problems resulting from unfavorable climate changes. Suddenly, violence ‘explosion’ led to the civilization collapse and rapid depopulation. It led to the disappearance of the ‘ruling’ clan.

Figure 2 presents population changes of Rapa Nui population in the semi-log scale, directly recalling the exponential portrayal via Malthus Equation (5) or Weibull-type Equation (1) with the exponent $\phi = 1$. It is worth noting that there was an extra increase in population from about 1500 to the beginning of the 17th century. In Europe, it was a time of significant improvement in climatic conditions, which probably also had a global scale. The middle of the 17th century corresponds to the Little Ice Age and strong cooling.

On Rapa Nui there was an extremely brief stabilization of the population and a very rapid decline, which can be related to the reasons mentioned above. However, this picture may be oversimplified. The last decade studies have shown that Rapa Nui people have developed advanced eco-friendly gardens in the central parts of the island (Hunt & Lipo, 2012, Lima et al., 2020). There are indications that a giant tsunami wave (Pollard et al.) or extreme rains caused by so-called atmospheric rivers could sweep the Rapa Nui (Carvaja et al., 2021) and destroy food resources. The importance of the above factors can be significant and complicate the picture of Rapa Nui population changes.

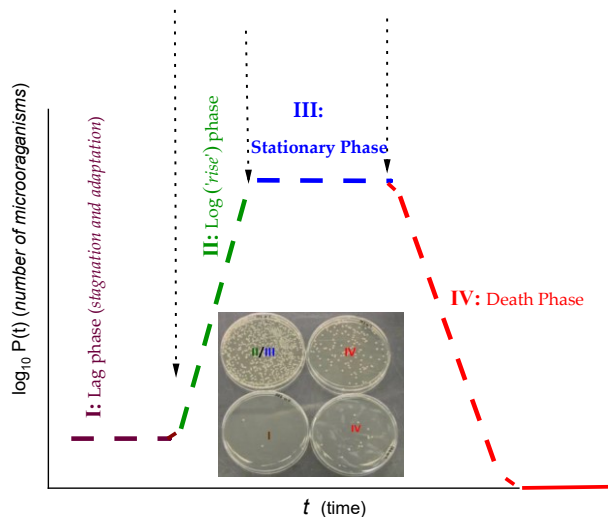

Figure 3: The illustration of the evolution of microorganisms population development in a closed container with a defined (limited) amount of food. The semi-log scale facilitates the manifestation of the single-relaxation (Equation (5) or Equation (1)) with the exponent $\phi = 1$. The photo presents E-Coli bacteria colonies in subsequent development stages (Rzoska et al., 2017).

Figure 3 shows changes of bacteria population in a container with a limited food amount. The semi-log-scale reveals the Malthus-type rise (phase II) followed by the stationary phase (phase III). Phases II and III together can be related to the Velhulst bimodal model (Equation (7)). Finally, the population disappeared (phase IV). The evolution of the bacterial population, which can also be considered the active Soft Matter, is similar to the population change in Rapa Nui.

However, there are some important differences. First, the stationary phase in **Figure 2** was extremely short. Second, the rise and decay were asymmetric for the Rapa Nui population (**Figure 2**). It can be related to the fact that the development and survival of the human population of Rapa Nui were strongly related to internal self-ordering. Its destruction occurred in a 'rapid' manner and in a short period. For bacteria population, such factor is obviously absent.

3. Population Evolution: hallmark post-industrial cities case

The question arises whether population changes evoking analogies to the dynamics of collective phenomena within Soft Matter Science may appear for human 'clusters', where interactions with the surrounding seem to be obligatory. To discuss this issue, the population development of a few hallmark post-industrial cities in Poland and the USA is discussed, from the beginning of the 19th Century until now. The differences between the situation in the respective countries are emphasized.

In the 19th Century, Poland did not exist, and its territory was divided between the three partitioning empires, Russia, Prussia / Germany, and Austria (Davies, 1996). For each of them, social and economic development followed a different path. Poland regained independence in 1918. It was 123 years of occupation by autocratic empires but also a time of nation formation. Unfortunately, Poland was located between them and became the arena of great wars caused by them. Poland was one of the main arenas of World War I (WWI), leading to enormous destruction and impoverishment. Twenty years later, in 1939, World War II (WWII) broke out, causing Poland one of the greatest human and material losses. After the war, there was a forced change of borders and the subjugation to the Soviet-Russian Empire, which terminated in 1990. The situation of Poland in recent centuries is perfectly reflected by the title of the recent monograph 'God's Playground. A History of Poland' (Davies, 2015).

In turn, USA is a country that, from its beginnings throughout the 19th century, until now, is growing harmoniously (Seavoy, 2006). The US participated in WWI and WWII as the most important contributor (Seavoy, 2006). However, these wars occurred outside the territory of the USA, and as a result, the country was becoming more powerful and more prosperous, which is perhaps an unprecedented 'paradox' in history. In the USA, a country

on a continental scale, excellent pro-development conditions have always existed, mainly pro-economic, and pro-innovative, ... but also for personal freedom. The wars in which the USA participated, from the Civil War to WWI and WWII, not only did not ruin the country, but they became a fundamental factor intensifying its development (Seavoy, 2006).

What does the development of selected, specific cities look like in the context of such dramatically different countries? The main initial motive for their selection was the presence of a phase of strong population growth and then, after the stabilization phase, a rapid and significant decline in the population, which shows some similarity to model-patterns presented in **Figures 2 and 3**.

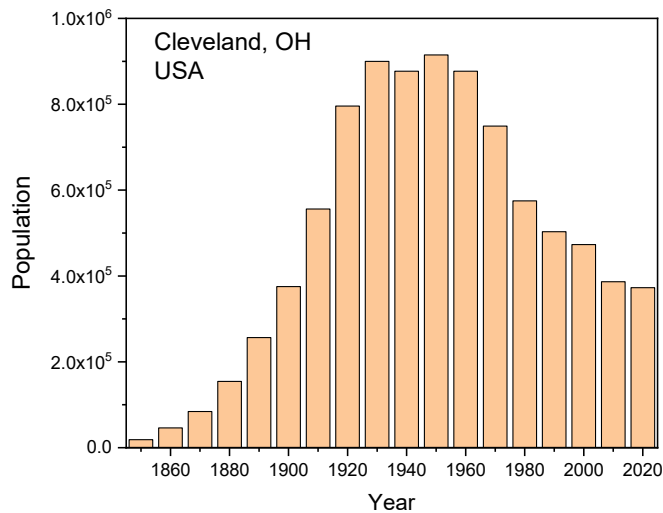

Figure 4. Population changes in Cleveland (Ohio, USA) in the classic bar presentation (based on Census, US: Cleveland, 2022).

Figure 4 shows population changes in Cleveland, Ohio (Census, US: Cleveland, 2022), in the semi-log scale, recalling the basic Malthus's behavior. Cleveland is a large city and harbor on the great Erie Lake coast. It developed as a significant transport hub. Its location, relatively in the far west of the USA, was of particular importance in the 19th and early 20th centuries, as it facilitated the transport of goods, ideas, and information by ships, which were then the dominant means of transport. Hence, for Cleveland the location constituted the crucial development motivator.

A significant driving force was also a variety of industries, primarily related to metallurgy. Cleveland has played the role of a financial, commercial, and scientific center (van Tassel & Grabowski, 1996). The latter is exemplified by three universities and the space research center. One cannot forget the famous Cleveland Orchestra. Despite such exciting characteristics, the population changes presented via the standard bar representation (**Figure 4**) show the stationary period after the substantial increase and a significant population decrease which continuous in the last 7 decades (!).

Figure 5 shows the analysis of population data from **Figure 4**, using the linearized, distortion-sensitive transformation of $P(t)$ data. via Equation (4). Following this dependence, linear domains validate the portrayal of $P(t)$ data by the powered Weibull-type exponential Equation (1), with slopes determining values of the power exponent ϕ .

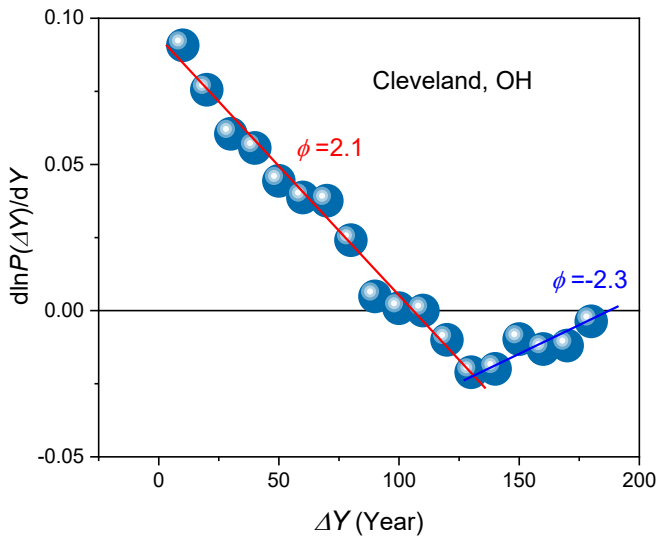

Figure 5: The linearized derivative-based analysis (Equation (4)) for the population changes $P(t)$ in Cleveland, Ohio, USA. The analysis is related to data given in **Figure 4**. Linear domains validate the portrayal via the empowered exponential Equation (1), with value of exponents ϕ values given in the plot. Y stands for time (t).

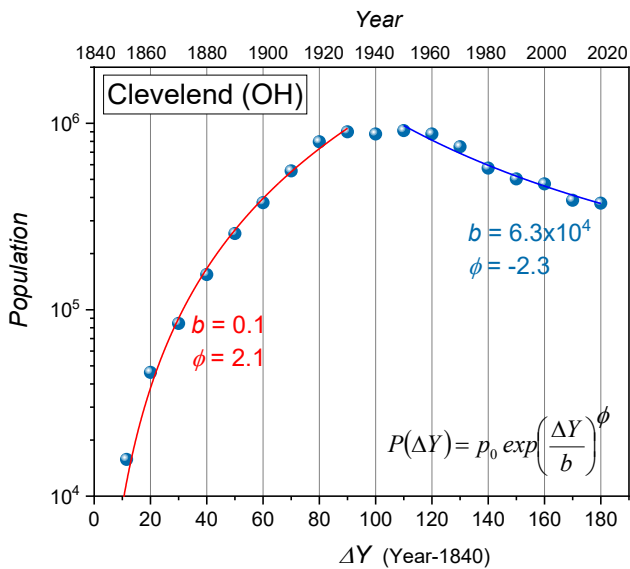

Figure 6: The semi-log presentation for the population of Cleveland, Ohio, USA, with the powered exponential portrayal of $P(t)$ changes via Equation (1). Note the link to parameters derived due to the analysis presented in **Figure 5**. Y stands for time (t).

Figure 6 shows the portrayal of population changes in Cleveland based on data presented in **Figures 4** and **5**. The long 'rise' and 'decay' domains are notable, with the stationary period between the years 1930-1950. The development of Cleveland was significantly motivated by the activity as the hub and exchange center for goods, information, and finances. The main factor which supported the development was initially the ship-based transport, possibly due to Great Lakes extending from the east to the far west of the USA. Rail transport rather complemented this at the beginning, but car/lorry transport and the development of the motorways/highways network changed the situation. The convenient port location ceased to be a crucial pro-development factor.



Figure 7 shows available population data for Detroit, Michigan, USA (Census US, Detroit, 2022) in the semi-log scale. It reveals the superior Malthus-type portrayal associated with the single-mode relaxation, linked to the exponent $\phi = 1$ in Equation (1), particularly since 1900. In an obvious way, the influence of the dominant industrial monoculture associated with the automotive industry is imposed here. However, the same development trend in Detroit seems to emerge already in the early 19th century. The thread of development determinism appears very interesting.

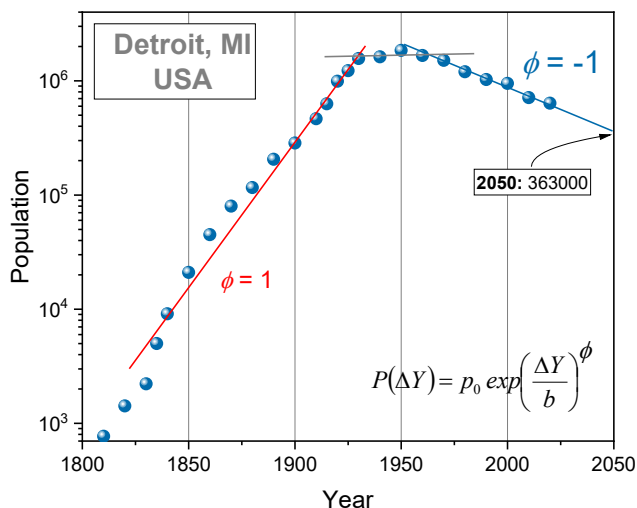

Figure 7: The population evolution in Detroit, Michigan, USA - in the semi-log scale. Solid lines represent the Malthus model type portrayal (Equation (5)), related to Equation (1) with the exponent $\phi = 1$.

Similarly to the respective pattern observed in Detroit, Michigan, USA (**Figure 7**), we found that based on the data from (Bytomski, 2022), a Malthus-type pattern associated with the exponent $\phi = 1$ in Equation (1) appears also in a very, very distant Bytom, Poland (**Figure 8**). In Bytom, the Malthus-type population increase extends from 1800 until 1980. It should be clarified here that Bytom is an old medieval town that turned out to be located in the center of one of the largest hard coal deposits in the world, of excellent quality. In the 19th century, it was the most important strategic energy resource. This factor defined the development of Bytom in the era of Industrial Revolutions, especially since the area of Bytom and Upper Silesia belonged then to the organizationally thriving Kingdom of Prussia, and then the German Kaiser’s Empire. However, the history of the 19th and 20th centuries had a dramatic impact on Bytom. The development trend of Bytom was continuous despite (i) two world wars (WWI, WWII), (ii) changes in government nationality: until 1918 the city was under the German Kaiser’s rule, from 1918 till 1945 it was included in the German Republic and in the Nazi-German state, (iii) since 1945, Bytom is a part of Poland, (iv) in years 1945/1946 the population exchange from German to Polish took place, (v) in 1989/1990 the shift occurred in the political and economic system from quasi-communist to the real world ‘capital’ economic (Davis, 1996, Bytomski 2022). Bytom is an old city, but its rapid rise was associated with rich coal deposits. Reducing the population can be associated with a rapid decline in the role of coal as a strategic energy resource. This decline is also Malthusian-type. It should be mentioned, however, that there was also a constant factor throughout the period in question that reflected the nature of the local population of Upper Silesia, with its own language constituted by a dominant old Polish language, a strong influence of the German language and a strong internal cultural identification.

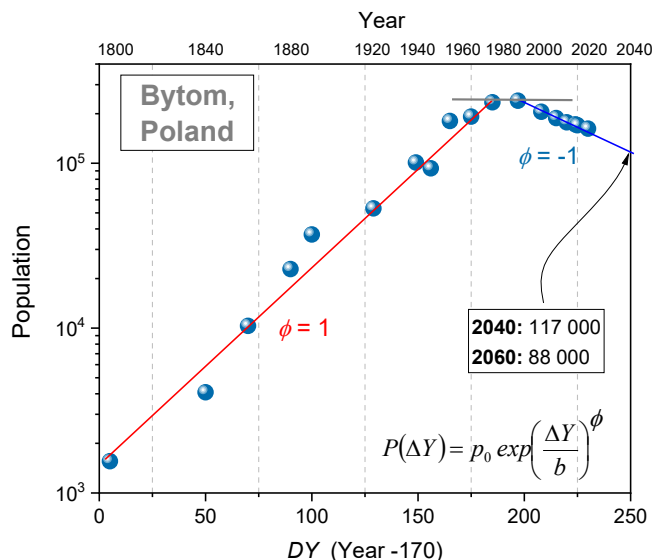

Figure 8: The evolution of the population in Bytom, Silesia, Poland - in the semi-log scale. Solid lines represent the Malthus-type portrayal (Equation (5)), related to Equation (1) with the exponent $\phi = 1$. *DY* stands for time interval (in years).

In Poland, one of the large symbolic cities with a declining population and various social and economic problems is Łódź, located approximately 140 km east of Warsaw. The history of this city is peculiar. It developed from a small village near the border between Tsarist Russian and Prussian/German empires (Davies, 1997). The encouragement introduced by the Tsar of Russia led to the creation of an exceptionally rapidly expanding textile center, compared to Manchester UK, in the second half of the 19th century (Popławska and Muthesius, 1986).

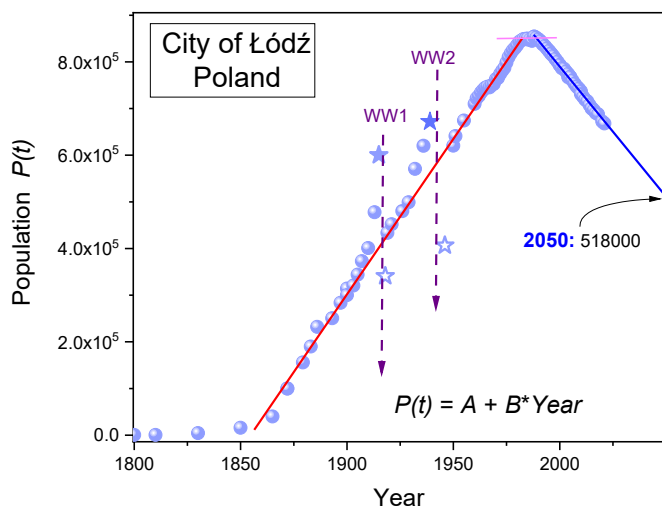

Figure 9: The evolution of the population in Łódź, Poland. Note the explicit linear dependencies during the increase and decrease of the population.

Figure 9 shows the extraordinary feature of the evolution of the population of Łódź. It increased linearly until the eighties, and later the explicitly linear decrease occurred. This suggests that the evolution is beyond the Malthus-type or powered-exponential patterns, which seemed to be universal (based on data avail at (Łódź w Liczbach, 2022)). Notable, till the year 1915, Łódź belonged to the Tsarist Russian Empire (Davies, 1996), and the enormous economic capacity of the Empire stimulated its development. Huge human



resources ready to work in the factories and the empire's market with proportionally huge needs presented a significant impact.

In the period between 1905 and 1914, increasing economic freedom boosted Russia's economy, which seems to reflect in the accelerated population growth in Łódź. In 1915, the enhanced population rise could be associated with WWI refugees. It was followed by a massive compulsory evacuation when the Russian army left the territory of Poland. The population increase before WWII can be linked to the enormous poverty after the Grand Crisis. The population collapse during WWII (1946) reflects the holocaust of Jewish citizens. They constituted a significant part of Łódź population before WWII.

After WWII, Łódź returned to a mass textile production for the benefit of the Russian empire, at that time in the form of the Soviet Union. Poland was the Soviet Union-dependent country ruled by so-called 'Polish communists'. This trend changed in the second half of the 1980s when the communist system deconsolidated (Davies, 1996). Since then, a permanent decline in the population - also linear and still lasting - has occurred.

4. Conclusions

This work develops the socio-economic soft matter concept for discussing population changes in selected post-industrial hallmark cities. First, the reference case of Rapa Nui population, geographically isolated from any impact for centuries, was discussed. The analogy of the pattern observed for a colony of bacteria in a closed container with a limited amount of food/resources was indicated. For the Rapa Nui population development, the impact of global climate change and internal social ordering seems to be also significant. Subsequently discussed post-industrial (contemporary) cities are related to environmental interactions. Nevertheless, the characteristics of their development tracked by population changes show noticeable similarities to the model case of Rapa Nui.

For Detroit, the uninterrupted and continuous "Malthusian" exponential growth, described by Equation (1) with an exponent $\phi = 1$, took place. It suggests a single dominant process/motivator of dynamic changes, described by a single relaxation time. It was suggested that the reason for the decrease in the population was the decline in the automotive industry impact (Hyde, 2001) which began in the mid-1960s (**Figure 7**). The decline in the population may result from a decrease in the demand for labor in the automotive industry and a relative reduction in wages. The automation and the associated increase in productivity and increasing competition from Asian and European producers influenced the dominant industry in Detroit, and consequently, the population of this largely mono-cultural city has decreased.

Population changes in Cleveland, Ohio are specific: both rise and decay have the Weibull-type dependence described by Equation (1) with the exponent $\phi \approx 2$. The city emerged as a significant transport and exchange hub due to its favorable location on the great Lake Erie coast. Its location, supported by various industries, has shaped the city's success for decades and led to strong population growth. However, since 1950, the population of Cleveland has continued to decline, which was also reflected in economic aspects. The 'powered' exponential Equation (1) describes both the increase and the decrease, which suggests that it is a multi-channel process related to a set of relaxation times. Let us recall that the economy of Cleveland was multi-faceted from the beginning but dependent on a single factor - a great harbor (van Tessel and Grabowski, 1996). The weakening of this driving-force factor had influenced the development trends of other 'development channels', affecting the development and population. Since the mid-1950s, the final dominance of trucks and modern railways transport has occurred in the USA (Seavoy, 2006), reducing Cleveland's role as the transport hub.

Note that Detroit and Cleveland are cities (i) located in the USA, which is a country of model freedom and business support (Seavoy, 2006), (ii) it is characterized by unprecedented mobility of the workforce (Seavoy, 2006), (iii) the permanent increase of the US population has taken place (Seavoy, 2006).

The perfectly one-channel 'Malthusian' population dynamics also appear in Bytom (Poland), a city distant from Detroit (**Figure 8**). In Bytom, essential changes related to the



nationality of citizens, governments, and the political system took place. They do not seem to be significant for the population changes. One may suggest that the driving force of the changes derive from huge deposits of high-quality coal. The depletion of deposits and unfavorable long-term price changes in the international coal market from the mid-1980s (Galata, 1997) limited the role of coal mining. The decay of the dominant economic stimulants started, resulting in a single exponential population decay in Bytom (**Figure 8**). It is worth recalling that population changes reflect the city's socio-economic attractiveness.

In Poland, Łódź symbolizes a city with problems associated with political system changes (Galata, 1997). Like Detroit and Bytom, Łódź was the city created and shaped for decades by a single industry related to large weaving and textile factories. Until WWI and after WWII, the production of this industry was consumed, motivated by the enormous needs of the Russian empire, no matter whether governed by Tsaristic imperialists or Soviet-dependent so-called 'communists' (Davies, 1996). At the end of the 1980s, this factor practically disappeared, and competitive and cheaper textiles from Asia appeared, which won the market in Poland. Soon later, weaving factories collapsed (Szpakowska-Loranc and Matusik, 2020). Thousands of people lost jobs and the life-path concept. Often, they worked in textile factories for generations (Szpakowska-Loranc and Matusik, 2020). New work positions emerged very slowly. Such a situation caused a vast and probably still existing trauma that was strengthened by textile factories employing mainly women.

As stated above, the city's population changes can be associated with its economic attractiveness. The last factor should be treated not only in terms of salaries but also of expenses related to the life quality, price of housing, accessibility, and cost of social facilities, transport, etc. According to the authors, the specific dynamics of population changes in Łódź can be explained by developing Equation (1) in Taylor series for $\beta = 1$:

$$P(t) = p_0 \exp \left[\pm \left(\frac{\Delta t}{\tau(t)} \right)^{\beta=1} \right] \Rightarrow P(t) = p_0 \left[1 \pm \frac{\Delta t}{\tau} + \frac{1}{2} \left(\frac{\Delta t}{\tau} \right)^2 \pm \frac{1}{3} \left(\frac{\Delta t}{\tau} \right)^3 + \dots \right]. \quad (8)$$

where $P(t)$ represents population changes in selected units: thousands, millions, ... of inhabitants. With relatively small values of the argument or the influence of a parameter shaping a given trend, we can neglect the terms of higher order to get the linear evolution of the population

$$P(t) \approx p_0 \left[1 \pm \frac{1}{\tau} \Delta t \right]. \quad (9)$$

Such a situation may occur when the impact of the dominant economic force on the surrounding is realized via non-interacting 'channels', with negligible feedback interactions between them. As a result, additional power terms in Equation (8) are not activated, and the development of the city, also measured by the evolution of the population, is linear as given in Equation (9). In the opinion of the authors, the hypothetical minimal feedback effects that can create pro-development added value in Łódź can be associated with the unique situation that the dominant driving force were women, for all decades accepting worse working conditions, payment, and social environment (Szpakowska-Loranc and Matusik, 2020).

This situation is dramatically opposite to Bytom or the Upper Silesia region in general, where the authorities have always been afraid of the wrath of miners who were decisive men, moreover, they were well organized (Upper Silesia, 2023). So, isn't the still difficult situation of Łódź a legacy of decades or even centuries of economic exploitation of women, who were the main working force in textile factories?

In summary, it can be stated that some aspects of the development of selected urban centers can be considered as a Socio-Economic Soft Matter entity, with the population dynamics described and explained by models that are relevant also in Soft Matter Science. The environment seems to be a kind of averaging factor - in Soft Matter it can be described as a 'mean field approximation', which results in a qualitative simplification of the description of important processes. In such an approach, population changes are 'managed' not only within an example of bacteria in a container or population in the Rapa



Nui island but also by the existence of an 'attractor' in a given city, attracting people from outside the city, which in turn may start to leave the city when the attractor weakens or disappears completely if a much stronger other attractor appears nearby. In Poland, an example of such a new strong attractor can be Warsaw, located relatively close to Łódź, currently well connected, with attractive jobs for various professions. An interesting and surprising factor may be the 'dominant trend' in urban development appearing exceptionally early. An example is Detroit, where the car industry emerged at the beginning of the 20th century, but the same development trend has existed since the beginning of the 19th century. According to the authors, this issue may be related to the question of why the center of innovation in the automotive industry was established in Detroit? Maybe the reason was the pro-innovation potential there that led to it? Another somewhat surprising issue is the practical symmetry of the population growth and decline trends and the durability of the latter despite significant, positive countermeasures that are taken, for example, in Cleveland and Łódź. The last factor is the universality of the processes because the cities considered here were subjected to qualitatively different historical and socio-economic conditions.

Conflicts of Interests: the authors declare no competing interests

Contribution: the authors declare equal contributions regarding research and manuscript preparation issues.

Data availability: the authors declare the availability of data on requests to the authors.

Funding: This research is not related to any specific grant from funding agencies in the public, commercial, or not-for-profit sectors.

References

1. Bytomski (2022): <https://forum.bytomski.pl/historia-miasta-i-zabytki/114729-zmiany-ludnosc-bytomia>. Accessed: 28.02.2023
2. Buzrul S. The Weibull Model for Microbial Inactivation. *Food Engn. Rev.* 2022; 14: 477-485. DOI: <https://doi.org/10.1007/s12393-021-09291-y>
3. Carvaja M, Winckler P, Garreaud R, Iguait F, Contreras-López M, Averil P, Cisternas M, Gubler A, Breuer WA. Extreme sea levels at Rapa Nui (Easter Island) during intense atmospheric rivers. *Natural Hazards* 2021; 106:1619–1637. <https://doi.org/10.1007/s11069-020-04462-2>
4. Census, US: Cleveland, Ohio (2022): <https://www.census.gov/quickfacts/clevelandcityohio> Accessed: 28.02.2023
5. Census, US: Detroit, MI (2022): <https://censusreporter.org/profiles/16000US2622000-detroit-mi/>. Accessed: 28.02.2023
6. Chadwick O, Puleston C, Ladegofed T, Stevenson C. Variation in Rapa Nui (Easter Island) land use indicates production and population peaks prior to European contact. *Proc. Natl. Acad. Sci.* 2015; 112: 1025-1930. DOI: 10.1073/pnas.1420712112
7. Davies, N. *Heart of Europe: a Short History of Poland*. Oxford Paperbacks, Oxford. 1996. ISBN: 978-0192851529
8. Davies N. *God's Playground. The History of Poland*. Oxford University Press, Oxford, 2015). ISBN: 9780199253395
9. de Gennes PG, Badoz J. *Fragile Objects: Soft Matter, Hard Science, and the Thrill of Discovery*. New York: Springer Verlag, 1996
10. Drozd-Rzoska A. Pressure dependence of the glass temperature in supercooled liquids. *Phys. Rev. E.* 2005; 72: 041505. DOI: <https://doi.org/10.1103/PhysRevE.72.041505>
11. Drozd-Rzoska A, Rzoska SJ. Complex relaxation in the isotropic phase of n-pentylcyanobiphenyl in linear and nonlinear dielectric studies. *Phys. Rev. E.* 2002; 65: 2885-2889. DOI: <https://doi.org/10.1103/PhysRevE.65.041701>
12. Drozd-Rzoska A, Rzoska SJ, Pawlus S, Ziolo J. Complex dynamics of supercooling n-butylcyanobiphenyl (4CB). *Phys. Rev. E.* 2005a; 72: 031501. DOI: <https://doi.org/10.1103/PhysRevE.72.031501>.



13. Drozd-Rzoska A, Rzoska SJ, Imre, AR. Liquid–liquid phase equilibria in nitrobenzene–hexane critical mixture under negative pressure. *Phys. Chem. Chem. Phys.* 2005b; 6: 2291-2294. DOI: <https://doi.org/10.1039/B315412B>
14. Drozd-Rzoska A, Rzoska SJ, Pawlus, S, Tamarit, JL. Dynamics crossover and dynamic scaling description in vitrification of orientationally disordered crystal. *Phys. Rev. B.* 2006; 73: 224205. DOI: <https://doi.org/10.1103/PhysRevB.73.224205>
15. Drozd-Rzoska A, Rzoska SJ, Pawlus S, Martinez-Garcia JC, Tamarit JL. Evidence for critical-like behavior in ultraslowing glass-forming systems. *Phys. Rev. E* 2010; 82: 031501. DOI: <https://doi.org/10.1103/PhysRevE.82.031501>
16. Feroze N., Tahir U., Noor-ul-Amin M., Nisar K.S., Algahtani M.S., Abbas M., Ali R., Jirawattanapanit A. Applicability of modified weibull extension distribution in modeling censored medical datasets: a bayesian perspective. *Sci Rep* 2022, 12: 17157. <https://doi.org/10.1038/s41598-022-21326-w>
17. Galata S. The Transformation of Poland's Economic System: 1985-1995. *Canadian Slavonic Papers / Revue Canadienne des Slavistes* 1997; 39, 27-45. <https://www.jstor.org/stable/40869888>
18. Gildea R, Mark J, Warring A. *Europe's 1968: Voices or Revolt.* Oxford Univ. Press, Oxford, 2013. ISBN: 9780199587513
19. Golosovsky, MA. Models of the World human population growth- critical analysis, (2009). eprint arXiv:0910.3056
20. Golosovsky MA. Hyperbolic growth of the human population of the Earth: analysis of existing models", in "History and Mathematics", pp. 188-204. Ed. by Grinin, L., Herrmann, P., Korotayev, A., and Tausc A, Uchitel Publishing house, Volgograd, Russia (2010); available at arXiv:0910.3056v1
21. Goodby JG, Gray GW. Obituary: Pierre Gilles de Gennes, Mon. 4th Jun, 2007 edition. Available from: <https://www.theguardian.com/science/2007/jun/04/guardianobituaries.obituaries>. Accessed: 28.02.2023
22. Groumpos P. A critical historical and scientific overview of all industrial revolutions. *IFAC* . 2021; 54: 464-471. <https://doi.org/10.1016/j.ifacol.2021.10.492>.
23. Hunt TL, Lipo CP, Ecological catastrophe, collapse, and the myth of ecoside on Rapa Nui (Easter Island). *PERC Res. Pap.* 2012, 12: 21-44. DOI: <https://dx.doi.org/10.2139/ssrn.2042672>
24. Hyde CK. Detroit the Dynamic": The Industrial History of Detroit from Cigars to Cars. *Michigan Hist. Rev.* 2001; 27, 57-73. <https://doi.org/10.2307/20173894>
25. Kaack LH, Katul GG. Fifty years to prove Malthus right. *Proc Natl Acad Sci U S A.* 2013; 110: 4161-4162. DOI: <https://doi.org/10.1073/pnas.1301246110>
26. Lima M, Gayo EM, Latorre C, Santoro CM, Estay SA, Cañellas-Boltà N, Margalef O, Giralt S, Sáez A, Pla-Rabes S, Chr. Stenseth N. Ecology of the collapse of Rapa Nui society. *Proc. R. Soc. B* 2020; 287: 20200662. DOI: <https://doi.org/10.1098/rspb.2020.0662>
27. Łódź w liczbach (eng: *Lodz in numbers*) (2022): <https://uml.lodz.pl/>. Accessed at 28.02.2023
28. Malthus TR, Stimson SC. *An Essay on the Principle of Population: The 1803 Edition*, New Haven: Yale University Press, 2018. DOI: <https://doi.org/10.12987/9780300231892>
29. Mezzenga R, Shurtenberger, P, Burbidge A, Michel M. Understanding foods as soft materials. *Nature Mater.* 2005; 4: 729–740. DOI: <https://doi.org/10.1038/nmat1496>
30. O'Leary D. *Rapa Nui, Easter Island. Puerto Rico: Floricanto Press, 2021.* ISBN: 978-1099750267
31. Pollard J, Paterson A, Welham K. Te Miro o'one: the archaeology of contact on Rapa Nui (Easter Island). *World Archaeology* 2010; 42: 562-580. <https://doi.org/10.1080/00438243.2010.517670>
32. Popławska I, Muthesius S. Poland's Manchester: 19th-century industrial and domestic architecture in Lodz, *J. Soc. Architect. Hist.* 1986; 45, 148-163. DOI: <https://doi.org/10.2307/990093>
33. Rinne H. *The Weibull Distribution: A Handbook (1st ed.)*. Chapman and Hall/CRC. 2008. DOI: <https://doi.org/10.1201/9781420087444>.
34. Rzoska AA. Econo- and Socio- Physics based Remarks on the Economical Growth of the World. *Turk. Econ. Rev. (TER)* 2016; 3: 82-89. Available at : <http://www.kspjournals.org/index.php/TER/article/view/615>
35. Rzoska SJ, Drozd-Rzoska A. Dual field nonlinear dielectric spectroscopy in a glass forming EPON 828 epoxy resin. *J. Phys.: Condens. Matter.* 2011; 24: 035101. DOI: 10.1088/0953-8984/24/3/035101.
36. Rzoska AA, Drozd-Rzoska A. Global Population Growth as Socio-Economic Soft Matter System Dynamics Evolution. *Physics. Soc-ph.* 2022; arXiv:2209.01407 [physics.soc-ph]. DOI: <https://doi.org/10.48550/arXiv.2209.01407>
37. Rzoska, SJ, Ziolo, J, Drozd-Rzoska A. Stretched relaxation after switching off the strong electric field in a near-critical solution under high pressure, *Phys. Rev. E* 1997; 56: 2578-2581. DOI: <https://doi.org/10.1103/PhysRevE.56.2578>.
38. Rzoska SJ, Rosiak E, Rutkowska M, Drozd-Rzoska A, Wesolowska A, Borszewska-Kornacka, MK. Comments on the high pressure preservation of human milk. *Food Sci. and Nutr. Studies* 2017; 1: 17-28. DOI: <https://doi.org/10.22158/fsns.v1n2p71>
39. Seavoy R. *An Economic History of the United States: From 1607 to the Present.* Routledge, New York, 2006. ISBN: 978-0415979818



40. Serra F, Tkalec U, Lopez-Leon L. Topological Soft Matter. *Front. Phys.* 2020; 11: 1- 108.
DOI: <https://doi.org/10.3389/fphy.2020.00373>
41. Smith A. *The Wealth of Nations*. Digireads,UK, reprint edition, 2009: reprint from the first edition in 1776.
42. Szpakowska-Loranc E, Matusik A, Łódź – Towards a resilient city. *Cities*. 2020; 107: 102936.
DOI: <https://doi.org/10.1016/j.cities.2020.102936>
43. Stevenson CM, Jackson TL, Mieth A, Bork H-R, Ladefoged TN. Prehistoric and early historic agriculture at Maunga Orito, Easter Island (Rapa Nui), Chile. *Antiquity* 2006; 80: 919-936.
DOI: <https://doi.org/10.1017/S0003598X00094515>
44. Thedford RP, Yu F, Tait WRT, Shastri K, Monticone F, Wiesner U. The promise of soft matter enabled quantum materials. *Adv. Mat.* 2022; 35: 2203909. DOI: 10.1002/adma.202203908
45. Upper Silesia. https://en.wikipedia.org/wiki/Upper_Silesia. Accessed 15.03.2023
46. Van Tassel DD, Grabowski JJ. *The Encyclopedia of Cleveland History*, Indiana University Press; Cleveland, 1996. ISBN: 978-0253330567
47. Velhulst PF. Deuxieme Memoire sur la Loi d'Accroissement de la Population. *Mémoires de l'Académie Royale des Sciences, des Lettres et des Beaux-Arts de Belgique* (1847); 20: 1-32. <https://eudml.org/doc/178976>.
48. Weil DN, Wilde J. How relevant is Malthus for economic development today? *Amer. Econ. Rev.* 2010; 100: 378–382. Available from: <https://www.ncbi.nlm.nih.gov/pmc/articles/PMC4112762/>
49. Westfall RS. *The Life of Isaak Newton*. Cambridge Univ. Press. 1994.
DOI: <https://doi.org/10.1017/CBO9781107050334>





Invited lecture/Scientific contribution

The Mesoamerican Sound Heritage in Current Argentinian Music for Flute

Mastruzzo Ana Ligia^{1*}

1. Conservatorio Superior de Música "Manuel de Falla", Buenos Aires, Argentina.
- * Correspondence: Ana Ligia Mastruzzo; analgiamastruzzo@gmail.com

Citation: Mastruzzo A L.
The Mesoamerican sound heritage in current Argentinian music for flute. Proceedings of Socratic Lectures. 2023, 8; 149-155.
<https://doi.org/10.55295/PSL.2023.II19>

Publisher's Note: UL ZF stays neutral with regard to jurisdictional claims in published maps and institutional affiliations.



Copyright: © 2023 by the authors.
Submitted for possible open access publication under the terms and conditions of the Creative Commons Attribution (CC BY) licence (<https://creativecommons.org/licenses/by/4.0/>).

Abstract:

The theme of the discussion is the influence of Mesoamerican culture legacy in the Argentinian contemporary music for flute. The aim of the article is to analyse the piece "Coyolyantototl" (in Náhuatl language meaning place of action of the rattle bird) for Pre columbian flute, flute and recitation in Náhuatl (one performer) composed in 2021 by Federico Núñez and dedicated to Argentinian- Italian flutist Ana Ligia Mastruzzo. Also it was the aim of the article to find the connections between Mesoamerican legacy and the actual musical productions in Latin America.

Keywords: Mesoamerican culture; music; Flute; Mexicas; Contemporary music; Prehispanic instrument

1. Introduction

Mesoamerican culture has left its mark over time and, without a doubt, its great influence on the musical thinking of Latin American composers. The present work aims to give a perspective on contemporary Argentine flute music, emphasizing these cultural influences and how they are reflected in current artistic creation in the aforementioned region. For this, it was decided to analyse the case of the piece *Coyolyantototl* by the Argentine composer Federico Núñez, written in 2021 and dedicated to the author of this article. There will be a tour of musical interpretive aspects, the pre-Columbian instrument and the Nahuatl language used in the piece.

2. The case of the piece *Coyolyantototl*

In recent years, I have been working closely with the Argentine composer and guitarist Federico Núñez in the creation of the work *Trilogía Mexica* for flute, pre-Columbian double flute and recitation in Nahuatl language, conducted by one interpreter.

The work, as its name says, consists of three pieces:

1. *Kuikatl* (singing in Náhuatl language) for solo bass flute
2. *Quetzali* (the woman who was born to be beautiful or, feather in Nahuatl language) for solo piccolo flute
3. *Coyolyantototl* (the place of action of the rattle bird in Nahuatl language) for flute, double clay flute and recitation in Náhuatl (for one interpreter).

It is in the third piece of the *Trilogy* that we see with greater emphasis the approach to Mesoamerican culture and heritage in current flute music, since it is in it that the Náhuatl language is used, on the one hand, and on the other, of an instrument of the Mexican culture: the ceramic double flute (Figure 1).



Figure 1: Ceramic double flute replica made by argentinian ceramist Esteban Valdivia played by Ana Ligia Mastruzzo in concert at Conservatorio Superior de Música “Manuel de Falla” in Buenos Aires, on the premiere of chamber opera *Mexica Otlatocalitzli* by Federico Núñez in August 2022. Photo by Cecilia Salas.

Coyolyantototl, for transverse flute; Pre-Hispanic ceramic double flute and recitation in Náhuatl (an interpreter) is a piece made up of three parts: 1 – “Teotl (God of movement); 2 – “Oncuicatinemi” (Go singing) ; 3 – “Totol” (Bird) and invites the listeners to immerse themselves in an imaginary Mesoamerican past through the combination of the timbres of the original language, the replica of a Mesoamerican clay flute and a modern Western instrument such as the transverse flute. In this way the aesthetic idea consists fundamentally of exploring timbre combinations in the performance game that occurs during the piece. The encounter of Mesoamerican and Western civilization occurs from the organic of the musical piece.

The work was published in 2021 by the North American publishing house Cayambis Music Press¹ and is part of Ana Ligia Mastruzzo’s upcoming record, an integral of all the pieces for flute by Federico Núñez.

2.1. The double clay flute and the musical notation

Regarding the use of the instrument in the mentioned piece, the ceramic double flute, we can say that in Mesoamerican culture they have all kinds of flutes, except the transverse and nose flutes: plunger, spring loaded with double diaphragms flutes type quena, recorders, bitonal ocarina doubles in the form of a pair of birds and bitonal ocarina with vibrator depicting a mother nursing her child.

This double flute consists of two tubes with twin fingerings, so there is a possibility of playing different ways. Being made up of two similar tubes of the same length, and being built by hand without moulds, the resulting acoustic effect is that a close vibration or *battimento* is generated when the flute is blown. In the Coyolyantototl score there are the fingerings that were developed by the composer. They are very clear: the left hand corresponds to the left side of the line and the right hand to the right side (**Figure 2**).

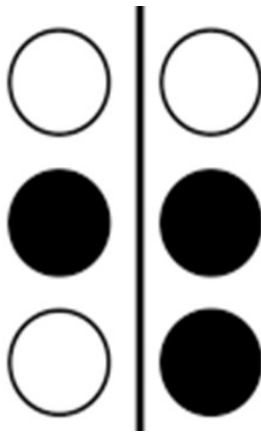

Figure 2: Example of fingering used in the piece Coyolyantototl

The notation for this instrument is an original creation developed by the composer for this type of instrument, since there is no conventional musical notation for it. It was tested by Ana Ligia Mastruzzo as the composition of the work developed, in a roundtrip between composer-performer. In this way, it was possible to verify the effectiveness of the unprecedented notation from the beginning of the composition.

¹ Information about the music sheet in Cayambis Music Press web site: <https://www.cayambismusicpress.com/federico-nunez-coyolyantotol-p/cmp-1580.htm>



There are some precedents for this type of notation development that can be found, for example, in the works of the Bolivian composer Cergio Prudencio, who also works in this way (commented by Sebastián Zuleta, a member of the Bolivian Experimental Orchestra of Native Instruments (OEIN) founded by Prudencio, (Zuleta, 2007):

“Since these instruments do not belong to the European ‘cult’ music tradition, and trying to find a notation more similar to the traditional conception, C. Prudencio writes in positions. It is specified in a graph which holes must be covered and/or uncovered and that is a position, for which the sign of an approximate pitch on the staff is determined”².

As this flute is an instrument that is outside the tempered system and convention, the composer reported in his Master degree thesis “La obra para guitarra sola de Fernando Maglia: Relación entre técnicas de ejecución y lenguaje” (Núñez, 2017) that he worked “following the manner of Luciano Berio, specially at the Sequenza 11th for Guitar where the tuning of the six strings provides the guitar language (Porcaro, 2003), and other composers of the 20th century, the idiomatic language of the instruments, this is contemplating not only the technical possibilities but fundamentally, the organological nature of the same”.

1.3 About the performance: music and words

For the performance of this piece, the double flute should be hung on the neck to facilitate the movements of the performer. The piece requires a lot of skill to go from one instrument to another and from instrument to voice. This flute hangs while the transverse flute can be left on a table or on a flute stand.

We can notice an alternation of onomatopoeias and Náhuatl language. These onomatopoeias serve as a link in order to acquire the continuity of the piece and enable the performer to move from one instrument to another. It is recommended to use an amplification that allows to balance the sound planes of the voice and of the instruments. The texts were provided by mexican poet Cuauhtémoc Vite. They are translations of some anonymous poems. The compiler refers in this regard:

“I took the idea from Giovanale Ancina, of creating or adapting “spiritual” texts for an oratorian purpose – spiritual or religious – with dialogues in short verses to give the adequate expression of vividness that is required. And from the same oratory, the text could be recited –chronista– as in the puppet altarpieces, in the style of “El retablo del maese Pedro”, by De Falla.”³

The texts used in their original language and also translated into English are transcribed below.

² “Al no pertenecer estos instrumentos a la tradición de música ‘cult’ europea, y tratando de encontrar una notación más afín a la concepción tradicional, C Prudencio escribe en posiciones. Se especifica en una gráfica cuáles orificios deben ser tapados y/o destapados y eso es una posición, para la cual se determina el signo de una altura aproximada en el pentagrama” (The traduction is my own).

³ Conversation between Núñez and Vite.



COYOLYANTOTOTOL (PLACE OF ACTION OF THE RATTLE BIRD)

1- TEOTL (GOD OF MOVEMENT, OF BECOMING)

OPENING SERMON \ OFFERING

Noncuica yehyan, noteuh.

Zan yehuan,

Ipal nemohua,

Ah notecu.

....

My song it is for him, who is my God.

Only he,

the giver of life,

Ah, my God.

2- ONCUICATINEMI (GO SINGING)

In coyolyantototl, oncuicatinemi, xochimana.

Zan ca tlauhquechol!

Piltotosin, ¿kenke ticuica?

Na nicuica pampa niyoltok

Na nicuica pampa nitlayejyekmati

Ni cuica xochihuiconticac ye noyolio.

....

The rattlesnake bird is singing, offering flowers.

Red bird with a rubber neck!

Little bird, why are you singing?

I sing because I have life

I sing because I see beautiful things

I sing with flowers covering my heart

3- TOTOTL(trans. God of movement)

BEGINNING OF THE SONG DIALOGUE

In izquixochitl, cacahuaxochitl,

Ah zan xochicacahuatl

In puzontimani,

Ocquihualya xochiaoctli y ya!

Ma ya netotilo,

Ma necuicatilo!!!

....

Fragrant flower, precious flower,

The flourishing cacao

already has foam,

Let's drink the florido liquor!

Let the dance begin,

the dialogue of the songs begins!!!

It is highly recommended that the performers have experience and knowledge in recitation and theater to be able to better approach this work and any other that requires the use of the voice by the interpreter.

The piece contains a series of questions to take into account at the time of its study and interpretation. Regarding the recitation, this is always clarified in the score with a rhythm to be respected that serves as a guide for the cadence of the words and syllables, without therefore having to be strict or too rhythmic. It must flow naturally. In the first piece, the voice is recited in the form of a whisper, respecting the indicated rhythm and using onomatopoeias « nu » that are interspersed between the sounds of the transverse flute and



the double flute. Here the interpreter must achieve a sound environment of lightness and fluidity, thinking of the God of movement that names the piece. There is a non-linear timbre transfer between the flutes where finally the double flute together with the onomatopoeias closes the number. In this way, a kind of timbral modulation is generated from the transverse flute to the double flute, carried out gradually, where the Náhuatl language functions as a link or as a distracting element.

In the second part the recitation is spoken and functions as an introduction that begins the section playing exclusively on the ceramic double flute. The spirit here is that of joy, it is an ode to beauty, to birds, to song, to love. It is very important to feel confident with the fingerings and to explore the sounds of this new instrument in order to convey the spirit of the piece. It is recommended to memorize the double flute section in order to feel comfortable with this flute. The last part has an indication of interpretation: « mechanical », here the interpreter must be very rhythmic and forget the lyrical issues of the previous part. It is a fast piece that requires a lot of skill to move quickly from one flute to the other and from flute to the whispered sections with onomatopoeias or the *bocca chiusa*. The text, unlike the two previous pieces, is inserted in the course of the work.

Given the characteristics of the piece, we find ourselves before a « new virtuosity » that is not the traditional one of the romantic pieces of European academic origin, but is typical of the world of contemporary music that shows new musical expressions seeking to break away from the Western academic tradition without denying its existence. Local features are mixed with the vestiges of tradition and European compositional techniques. The composer Mario Lavista defined this concept in his speech in Mexico (Lavista, 2010),

« The new virtuosity is one that contemplates a whole series of studies and searches for technical and expressive resources and possibilities absent from the classical instrumental tradition. It is not, in any way, about changing the nature of the instruments or destroy them ; You just have to listen carefully to discover in them a surprising diversity of voices and unusual worlds of sound. In this way, we participate and contribute to this slow and dignified transformation that instruments and their technique have undergone through the centuries. And it is the composer and the interpreter who contribute to it by trying to understand the complex nature of these alterations, of those innovations whose *raison d'être* resides, to a great extent, in the conflict that arises between the musical idea and the technique of execution. »⁴

In the case of *Coyolyantototl*, it goes much further than using invented melodies as composers such as Alberto Ginastera, Pascual De Rogatis, Silvestre Revueltas, Heitor Villa-Lobos and others have done ; here the protagonism is given by the replica of the ceramic instrument that contributes to the piece its organological characteristics and with it its own interpretative complexity. The double flute is in no way intended to resemble and imitate the transverse flute, but on the contrary, the piece is structured around it in such a way that the transverse flute and the voice modulate and transform to create an amalgamated sound unit.

A relevant aspect that requires extensive study and that will not be dealt with here is the dualistic Mesoamerican worldview that is manifested in the entire culture of the region and, as far as we are concerned, in the double structure of this flute.

Conclusion

The musical piece *Coyolyantototl* represents a paradigmatic creation of the rapprochement between Mesoamerican and European cultures that challenges the interpreter in endless questions to address, from interpretive-performative to cultural aspects. It is also true in

⁴ “El nuevo virtuosismo es aquel que contempla toda una serie de estudios y búsquedas de recursos y posibilidades de orden técnico y expresivo ausentes de la tradición clásica instrumental. No se trata, de ninguna manera, de cambiar la naturaleza de los instrumentos o de destruirlos; simplemente hay que escucharlos con atención para descubrir en ellos una sorprendente diversidad de voces e inusitados mundos sonoros. De esta forma, participamos y contribuimos a esa lenta y digna transformación que los instrumentos y su técnica han experimentado a través de los siglos. Y son el compositor y el intérprete los que contribuyen a ella tratando de comprender la naturaleza compleja de esas alteraciones, de esas innovaciones cuya razón de ser reside, en gran medida, en el conflicto que surge entre la idea musical y la técnica de ejecución”. (Traduction of my own).



terms of the treatment of stylistic and instrumental resources, since it marks an unprecedented way of connecting different musical cultures through its own new musical grammar that is manifested throughout the course of musical discourse. Language, in this way, is freed from all rigidity and acquires formal relationships that are legitimized in the creation itself. The interpreter opens up a huge and rich panorama of issues to know. Several aspects that emerge from this musical composition and from this article remain to be delivered into the future, such as the use and importance of the Náhuatl language as a poetic-sound element, the particular conception of time and dualism in pre-Hispanic cultures and its influence on the creation and use of Mesoamerican musical instruments.

References

1. Lavista, M. (2010). *El lenguaje del músico (discurso)*. México: El Colegio Nacional.
2. Mastruzzo, A. L. (2022). *The Double Pre columbian flute in the piece Coyolyantotl*. Obtenido de Cayambis Music Press : <https://www.youtube.com/watch?v=7whcLttpojE&t=45s>
3. Núñez, F. (s.f.). Obtenido de <https://www.federiconunez.com.ar/>
4. Núñez, F. (2017). *La obra para guitarra sola de Fernando Maglia: relación entre técnicas de ejecución y lenguaje*. Mendoza: Tesis de Maestría. Universidad Nacional de Cuyo.
5. Porcaro, D. (2003). *A polyphonic mode of listening: Luciano Berio's Sequenza XI for guitar*. North Carolina: Tesis de Maestría. Chapel Hill: Faculty of the University of North Carolina .
6. Zuleta, S. (2007). *Acercamiento al trabajo compositivo de Cergio Prudencio para la OEIN a partir del análisis de La ciudad*. ISS. Revista Nuestra América , 9.

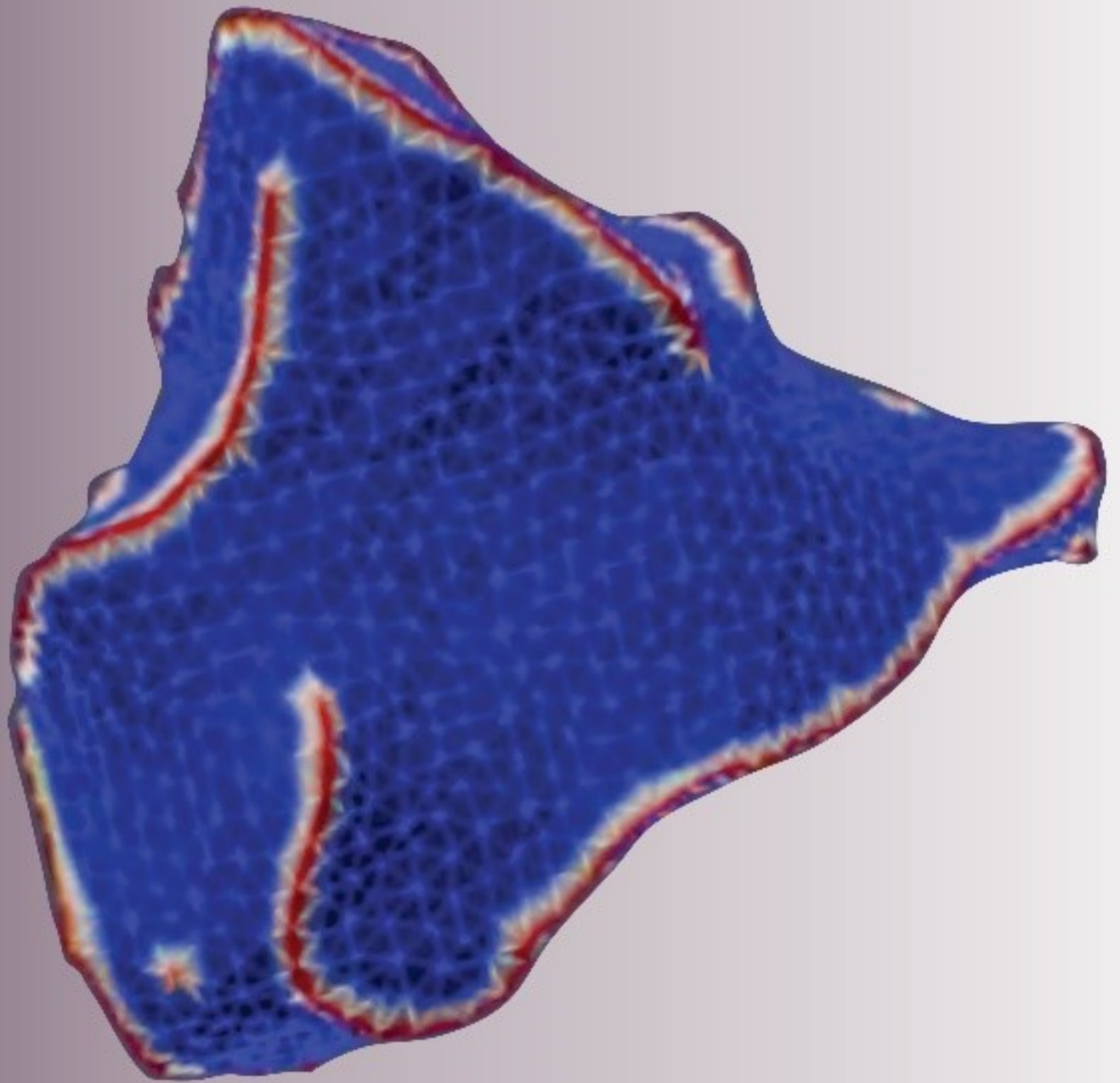



Invited lecture/Reflection

Music in the Life and Literary Works of Anton Pavlovich

Chekhov

Prevlovšek Anita*

* Correspondence: Anita Prelovšek: anita.prelovsek@gmail.com

Citation: Prevlovšek A. Music in the life and literary works of Anton Pavlovich Chekhov. Proceedings of Socratic Lectures. 2023, 8; 157-166. <https://doi.org/10.55295/PSL.2023.II20>

Publisher's Note: UL ZF stays neutral with regard to jurisdictional claims in published maps and institutional affiliations.

Abstract:

The purpose of the article is to present, with reference to a number of his stories and plays, the part played by music in Chekhov's works, which contain many borrowings from folk songs, Russian romances and classical music. The heroes of his works sing arias from operas, playing and singing the works of Russian and foreign composers. There are many extracts from the works of Tchaikovsky, with whom the writer enjoyed a relationship marked by mutual respect and friendship. Music in Chekhov's literary works embraces the whole of human life, covering a wide variety of emotions and situations described in many of the writer's works, which also include stories with purely musical titles. The article also briefly mentions some descriptions of Italy, a country much admired by the writer.

Keywords: Anton Pavlovich Chekhov;



Copyright: © 2023 by the authors. Submitted for possible open access publication under the terms and conditions of the Creative Commons Attribution (CC BY) license (<https://creativecommons.org/licenses/by/4.0/>).



1. Introduction

Anton Pavlovich Chekhov (1860-1904) was both a writer and a medical doctor, and medical doctors are repeatedly mentioned in his literary works, some of his heroes having characters similar to that of the writer himself. For example, the character of the medical doctor Samoylenko in the novella *The Duel*, who was “calm, extremely kind, soft-hearted and helpful”, giving people money and always standing up for the downtrodden, reminds one of Chekhov himself, who treated the sick free of charge during the cholera epidemic and, at his own expense, opened three schools, a post office and a telegraph service in his home village. He donated a library with more than two thousand books to his home town of Taganrog.

In his literary works Chekhov often mentions literature and music, his stories and plays embodying various references, quotations, parodies or influences from the works of other Russian and foreign writers, playwrights and poets. Sometimes these literary quotations also have a musical connotation, as the poets' verses were set to music by composers, or the literary works served as a template for the librettos of the operas referred to by Chekhov.

Chekhov's literary works frequently quote various Russian folk songs and ballads, as well as vocal and instrumental compositions by Russian and foreign composers. The lyrics and mood in these compositions often match what the literary characters are feeling or doing. Music is an important soundtrack to his plays. With music, he emphasizes the inner experience of his heroes, who often play music, go to concerts, talk about music or listen to it with pleasure.

2. Literary quotations in selected works of Chekhov

Examples from some of Chekhov's works where mention is made of Russian and foreign literature include the novellas *The Duel* and *The Story of an Unknown Man*, where Chekhov cites the Russian classics of Turgenev, Lermontov, Pushkin, Tolstoy and Dostoevsky, as well as the French writer Balzac (specifically his novel *Le Père Goriot*). In *The Story of an Unknown Man*, for example, the hero Orlov is a voracious reader, but other literary characters also have a formidable knowledge of nineteenth century Russian literature. These short stories by Chekhov contain several references to Russian classical works. His play *The Three Sisters*, for instance, mentions Gogol and Lermontov and the latter's poem 'The Sail'. In *Uncle Vanya*, he quotes Turgenev in relation to the romantic beauty of the environment: “Here you have the forests, the houses half in ruins that Turgenev writes of.” In the story that is sometimes defined as a novel, *The Shooting Party*, he also parodies excerpts from Ostrovsky's plays and tackles the subject of crime and the criminal, similar to Dostoevsky in *Crime and Punishment* and *The Brothers Karamazov*.

The duel in the novella of the same name reminds us of the duel in Pushkin's *Eugene Onegin*, but in Chekhov no one dies. With this novella, Chekhov also responded to the controversies about the acceptability of the duel in modern times which filled the Russian press in the 1880s (Chekhov 1947, p. 331; in the foreword by M. Javornik). The literary character Laevsky remains alive after a happy turn of events and suddenly sees his previously miserable life in a new light. He is overwhelmed by the joy of life and decides to work harder from now on. This character, condemned to death, who survives by a lucky chance, is somewhat reminiscent of Dostoevsky's own life as referred to in *The Idiot*.

3. Music in the literary works of Chekhov

Music was present in Chekhov's life since childhood, as his father Pavel Chekhov taught his children to sing in a choir. They sang at home and also in the church, where he was the leader of the choir. Chekhov spent his childhood in Taganrog, where more than half of the residents were foreigners, mainly Italians, Greeks, English and Germans. They organized concerts in which European musicians played and Italian and Russian operas were performed (I quote from: Gudkova). In *Ionitch* he describes life in the provincial town of S., which resembles the writer's home town: “Visitors to the provincial town S. complained of the dreariness and monotony of life; the inhabitants of the town, as though defending themselves,



declared that it was very pleasant in S., that there was a library, a theatre, a club and that balls were sometimes held."

In the cemetery of the town of S., there was a monument in the form of a chapel with a little angel on the top, dedicated to a lady called Demetti, because "An Italian opera had once visited S. and one of the singers had died; she had been buried here, and this monument erected in her memory. No one in the town remembered her, but the lamp at the entrance reflected the moonlight, and looked as though it were burning."

Chekhov's works contain many appreciative words about music, which for Chekhov is the joy of life; he also compares sounds from nature to music. In the novella *Ariadne* he writes: "When I am nailed up in my coffin I believe I shall still dream of those early mornings, you know, when the sun hurts your eyes: or the wonderful spring evenings when the nightingales and the landrails call from the garden and beyond, and sounds of the harmonica float across from the village, while they play the piano indoors and the stream babbles . . . when there is such music, in fact, that one wants at the same time to cry and to sing aloud."

Irina, the youngest sister in *The Three Sisters*, dreams of love and compares her soul to a precious piano: "My soul is like an expensive piano which is locked and the key lost."

Music from Verdi's operas was played in the homes of Taganrog. The writer's father, Pavel Chekhov, also loved music and organized private and public performances given by the family choir. Even members of the working class sang tunes from operas on the streets. As a young man, Chekhov went to symphony concerts and performances of operas and operettas. In his home town, he also heard the works of Tchaikovsky.

4. The meeting of Chekhov and Tchaikovsky

Chekhov and Tchaikovsky met in 1888. The first step was taken by the composer Tchaikovsky, who was twenty years older than Chekhov. Tchaikovsky read a lot and immediately spotted Chekhov's exceptional talent as a writer. In 1887, he read a short story by Chekhov in one of the newspapers that impressed him so much that he wrote a letter to the author and sent it to the newspaper's editorial office, though for some reason Chekhov never received it. Tchaikovsky also expressed his great enthusiasm for Chekhov's talent in a letter to his brother Modest, and the following year Chekhov visited the home of the poet Alexei Pleshcheev in St. Petersburg, where he became acquainted with the composer's brother. The next day (14 December 1888) he invited him to his house for breakfast, where Pyotr Ilyich was also present. The composer and the writer, who greatly appreciated each other's work, made a tremendous impression on each other when they met in person. The following year, Tchaikovsky visited Chekhov at his home in Moscow, and they exchanged several more letters that and the following year. Chekhov's acquaintance with the great composer was reflected in several of his works, which contain references to Tchaikovsky's compositions. Chekhov dedicated to Tchaikovsky a selection of stories that were published in 1890. The composer and the writer planned to create an opera based on Lermontov's works (the title of the opera was intended to be 'Bela', after the first part of Lermontov's novel *A Hero of Our Time*). Unfortunately, this project never came to fruition, as Chekhov went to Sakhalin in 1890, while Tchaikovsky left for Italy, dying three years later (I quote from www.tchaikovskyhome.ru and www.antonchehov.ru).

Chekhov often refers to Tchaikovsky's music in his works. In *The Story of an Unknown Man*, for instance, the literary hero attended Thursday evenings at the house of the host Orlov. He was the son of a general, had long fingers like a pianist's, and there was something reminiscent of a musical virtuoso in his whole body. Chekhov wrote that such figures play the first violin in orchestras, but in fact "He played a little on the piano. Sometimes he would sit down at the piano, play a chord or two, and begin singing softly: "What does the coming day bring to me?" The piece mentioned is Lensky's aria from Tchaikovsky's opera *Eugene Onegin*. This melody, which reappears in the story, relates to the unpredictable future of the main character, a revolutionary. In the story a man named Gruzin plays two more compositions by Tchaikovsky and a piece by Saint-Saëns, 'The Swan'.



In the one-act comedy *Jubilee*, Tatiana Alekseevna relates how a sailor, a chance random companion on the train, when he was told her name, sings: "Onegin, I can't conceal it, I love Tatiana madly!", an aria from Tchaikovsky's *Eugene Onegin*.

Tchaikovsky's music can also be found in the novella *My Life*. The heroine Masha sings the song 'Night': "She had a fine, mellow, powerful voice; and while she sang I felt as though I were eating a ripe, sweet, fragrant melon. She ended, the audience applauded, and she smiled, very much pleased, making play with her eyes, turning over the music, smoothing her skirts, like a bird that has at last broken out of its cage and preens its wings in freedom."

'Night' is a piece for voice and piano set to verse by Yakov Petrovich Polonsky (1819-98), a Russian poet who strove to continue the romantic poetic tradition of Alexander Pushkin. A Slovene romantic poet, Anton Aškerc, announced the news of his death in the 'Ljubljanski zvon' newspaper and described him as a famous Russian poet, like Majkov, Fet and Belinsky, who was "one of the epigones of the Pushkins" (Aškerc, 1898).

5. Operas and operettas

Chekhov's works also include mention of various operas such as "Rigoletto, The Huguenots and La Traviata!" in the novella *The Nervous Breakdown*. *The Huguenots* (*Les Huguenots*) is an opera by the German Romantic composer Giacomo Meyerbeer which he wrote for the Paris Opera.

The medical doctor in the novella *Three Years* is "a wretched, greasy miser, a sort of operatic Gaspard from "Les Cloches de Corneville," an operetta by the French composer Robert Planquett.

In the short dramatic monologue *On the Harmful Effects of Tobacco*, the narrator is a man whose wife runs a music school and a school for women. The protagonist sings the beginning of an aria, but he can't remember the origin: "But some of you, I'm sure, would rather hear a ballad, or a symphony, some aria" ... He sings. "We shall not shrink in the heart of battle: Forward, be strong." According to the Russian original (http://sunny-genre.narod.ru/books/yankovsky_1937/3-7.htm) it appears to be a choral aria from the operetta *Le petit Faust* by the composer Hervé (the pseudonym of Louis-Auguste Florimond Ronger, who wrote over 100 operettas (Kennedy and Bourne 1996, p. 335), a parody of Berlioz's opera of the same name. The libretto of this operetta, dating from 1869, was quite popular at the time and was translated into Russian shortly after its creation by Vasilij Kurochkin (1831-75), a journalist, poet and translator.

6. Russian folk songs and ballads

In *The Shooting Party*, which is sometimes described as Chekhov's only novel and was not translated into Slovenian until 2022, a gypsy choir performs under the direction of a choirmaster who accompanies him on the balalaika. The choir sings Russian gypsy ballads. Performances by gypsy singers were very frequent and popular at parties of the aristocracy. Even in the middle of the nineteenth century, these choirs were extremely widespread. Their repertoire also included Russian romances, the texts of which they wrote themselves and in Russian; they could also use the texts of Russian poets (I quote from: Čeredničenko).

As Chekhov says in relation to the ballad 'Nights of madness, nights of gladness', the words of the song are very romantic and exaggerated: "I began to dress and describe to the doctor what I had lately experienced of "Nights of madness, nights of gladness", which are so delightful and sentimental in the songs and so unsightly in reality." "Nothing acts more irritatingly, more titillatingly on my nerves than such rapid transitions. I trembled with rapture, and embracing Tina with one arm and waving the balalaika in the air with the other hand, I sang "Nights of madness " to the end."



Typical features of Russian romances include a strophic form, an instrumental introduction with a guitar, a more frequent minor tonality and frequent rhythms of a minuet, siciliano and waltz (I quote from: Čeredičenko). Three songs sung by gypsies are quoted in *The Shooting Party*: 'Akh Moskva, Moskva, Moskva, white-stoned Moskva', which is a song to a text by Count Vladimir Aleksandrovich Sollogub (1813-82); a Russian folk song 'Down the Volga' and the ballad 'Nights of madness, nights of gladness'. According to the Russian critical edition of Chekhov's story, 'Nights of madness, nights of gladness' is an inaccurate quote from Alexei Nikolayevich Apukhtin's poem from 1876, which was set to music by Tchaikovsky and other composers. Apukhtin (1841-93) was a close friend of Tchaikovsky and also dedicated some songs to him. In the 1880s, however, the text became the basis for a popular gypsy ballad, which appeared in various musical adaptations.

The Russian folk song 'Lutchina' is mentioned in *Ionitch*: "In the town gardens close by a band was playing and a choir was singing "Lutchina", the song being sung by the choir expressing sentiments not to be found in the novel, only in real life."

7. Music in the parks

Chekhov also mentions the music played in pavilions in the parks. In story *Ariadne*, for instance: "A military band, only just arrived from Fiume, with glittering brass instruments, sauntered by to the bandstand - they began playing."

What Chekhov wrote about Abbazzia (Opatija in Croatia) is interesting: "Have you ever been to Abbazzia? It's a filthy little Slav town with only one street, which stinks, and in which one can't walk after rain without galoshes. I had read so much and always with such intense feeling about this earthly paradise [...]. There is a calm bay there full of steamers and boats with coloured sails. From there I could see Fiume and the distant islands covered with lilac mist, and it would have been picturesque if the view over the bay had not been hemmed in by the hotels and their annexes - buildings in an absurd, trivial style of architecture, with which the whole of that green shore has been covered by greedy moneygrubbers, so that for the most part you see nothing in this little paradise but windows, terraces, and little squares with tables and waiters' black coats. There is a park such as you find now in every watering-place abroad. And the dark, motionless, silent foliage of the palms, and the bright yellow sand in the avenue, and the bright green seats, and the glitter of the braying military horns - all this sickened me in ten minutes!"

In the novella *Anna on the Neck*, Anna hears music being played by a band and becomes suddenly overwhelmed with joy. She sings a tune played by the orchestra, and the music soon helps her mood to improve.

8. Music in the everyday life of the heroes of Chekhov's stories

In the novel *Three Years*, music is an important element in the description of the provincial town where the story takes place: "There were gardens all along the lane, and a row of lime-trees growing by the fence cast a broad patch of shadow in the moonlight, so that the gate and the fences were completely plunged in darkness on one side, from which came the sounds of women whispering, smothered laughter, and someone playing softly on a balalaika. There was a fragrance of lime-flowers and of hay."

Music can contribute to create a happy mood and fill a person with optimism: "The bands are playing so gaily, so bravely, and one does so want to live!" we read in *The Three Sisters*. Music is also associated with memory. A song or a melody can bring back memories of past times, as in *Ionitch*, where a song is reminiscent of carefree young years. The provincial doctor, Dmitry Ionitch Startsev, sings "Before I'd drunk the tears from life's goblet...", this is an 'Elegy' based on the poetry of Anton Delvig (1798-1831), Pushkin's classmate at the lyceum in Tsarskoye Selo, whose works were set to music by Aljabljev and Glinka, among others. The music was written by Mihail Yakovliev (1798-1868), a friend of Pushkin and a composer and singer. Chekhov associates music and singing with a happy, joyful mood.



The hero of the story once walked home from a restaurant and sang all the way *"Thy voice to me so languid and caressing..."* These are the opening verses of Pushkin's poem 'Night', set to music by various Russian composers, such as Anton Rubinstein, Modest Mussorgsky and Alexander Grechaninov.

In Chekhov, many of the characters play, sing or just adore music. The heroine in *Ionitch* loves music and art, to which she wants to dedicate her life; she plays the piano and is preparing to study at the conservatory, although her talent is modest. She aspires to become an artist and seeks fame, success and freedom, something she never achieves.

Music can also be a topic of conversations between Chekhov's heroes. Thus, in the novel *Three Years* a friend of one rich family, named Laptiev, was a lawyer and a devoted lover of art. *"He neither sang nor played any musical instrument, and had absolutely no ear for music, but he attended all the symphony and philharmonic concerts, arranged concerts for charitable objects and sought the company of singers."*

In the novella *Tedious Story*, too, characters talk about music. A knowledge of music is also part of a general education: *"Gnekker and the girls talk of fugues and counter-fugues; singers and pianists, Bach and Brahms, and my wife, frightened of being suspected of musical ignorance, smiles sympathetically and murmurs: "Wonderful.... Is it possible? ... Why? ..."* Chekhov notes that not everyone understands music: *"In this town absolutely nobody understands music, not a soul except myself."* For the literary hero in the novella *The Story of an Unknown Man* also, *"Everything abstract, everything belonging to the domain of thought and feeling was to him boring and incomprehensible, like music to one who has no ear."*

In Chekhov's stories, a man hears music already in his cradle, when his nurse sings to him. Nannies and governesses were important in the lives of Russian people, so they also played a prominent role in literature. For example, in *Three Sisters*, one of the characters is the eighty-year-old nurse Anfisa, who in the second act of the drama sings a lullaby offstage.

Music also accompanies a deceased person on his last journey. Olga, one of the three sisters in the drama of the same name, remembers how at the funeral of her father *"there was music and they fired a volley in the cemetery. He was a general in command of a brigade but there were few people present."*

In the novella *Nervous Breakdown*, Chekhov even talks of music being played in brothels: *"Seeing two rows of houses with brightly lit windows and wide-open doors, and hearing gay strains of pianos and violins, sounds which floated out from every door and mingled in a strange chaos, as though an unseen orchestra were tuning up in the darkness above the roofs, Vassilyev was surprised."*

At concerts and at the opera, people meet, so these events, as they still are today, are places where social life takes place. In the novella *The Lady with the Dog*, only two characters appear: Anna Sergeevna and Gurov. Their meeting, after their acquaintance in Yalta, takes place in the theatre with a musical accompaniment. During the performance, Gurov thinks of Anna Sergeevna: *"she was his grief, his joy, his only happiness, and he longed for her; and through the noise of the bad orchestra with its tenth-rate fiddles, he thought how dear she was to him. He thought and dreamed."* They meet during the intermission of the spectacle. Their meeting is accompanied by the sounds of an orchestra: *"The fiddles and flutes began to play and suddenly it seemed to them as though all the people in the lodges were looking at them."* They feel as if they are being watched from all the lodges. Then she gets up and hurries towards the exit, while Gurov thinks: *"Oh, Lord! Why all these men and that beastly orchestra?" "The Cross of God! What are these people, this orchestra for..."*

In *Three Years*, the meeting with the hero's former love, who was a pianist and music teacher, takes place during a break at a symphony concert: *"On a Saturday in November Anton Rubinstein was conducting in a symphony concert."* A Ninth Symphony was also on the programme, but the author does not indicate whose. This musician, named Polina Nikolaevna Rassudina, is said to have studied at Guerrier's school and at the conservatory, and now she was teaching music and playing in quartets.



In the novel *Three Years*, singers sang at great length during the solemn prayer ceremony for the presentation of the bride to her father-in-law.

In *The Shooting Party*, in addition to gypsy choirs, Chekhov writes about the music in the church that accompanies the wedding ceremony: *"In the church itself there was also singing. . . . They sang sweetly, with feeling, and with the enthusiasm for which our Little Russian singers are so celebrated when they feel themselves the heroes of the moment, and that all eyes are bent upon them."*

Chekhov also wrote some stories about musicians: *Romance with a Double Bass*, *Rothschild's Violin*, *The Chorus Girl*, *Choristers*, *The Dance Pianist*.

9. Music in Chekhov's dramas

In Chekhov's last drama, *The Cherry Orchard* – really an inadequate translation of the play's title, which in the original is *The Marasca Orchard* (Вишнёвый сад) – sound and music play an important role. The first sound motif appears at the end of the first act, where *"In the distance, the other side of the orchard, a shepherd is playing his pipe."* The symbolism of a shepherd with a flute is linked to an idyllic romantic landscape. This idyll is now "in the distance"; it is no longer in the garden, as the property with the garden is to be sold and the trees will be cut down.

There are several musical elements in the next three acts. The entire second act is accompanied by singing and guitar playing. The merchant Epihodov always plays *"the same sad song on his guitar"*, a romance by Vasily Chuevski set to music by Alexandre Dubuque, a Russian pianist and composer of French origin who studied with the famous Irish pianist, composer and pedagogue John Field, who worked in St. Petersburg (Wikipedia). This we find out from the verses *"What is this noisy earth to me, What matter friends and foes?" I do like playing on the mandolin!"*

The third act of the drama takes place in the hall, where dances are held and there is a Jewish orchestra consisting of four violins, a flute and a double bass. The music in Chekhov's stories is also often present in the context of celebrations, as an accompaniment to dances and parties. One lady in this scene sings the lezginka, a Caucasian folk dance of the Lezgins, a predominantly Muslim people from the North Caucasus (Wikipedia). The orchestra plays all the time, and the didascalial also states when the music stops. The second time it happens is during the monologue by the merchant Lopakhin, who has bought the estate with its orchard of morello cherry trees: *"You can hear the orchestra tuning up"*, and the hero exclaims: *"Eh, musicians, play, I want to hear you! [...] Come and look at Ermolai Lopakhin laying his axe to the cherry orchard, come and look at the trees falling! We'll build villas here, and our grandsons and great-grandsons will see a new life here.... Play on, music! [The band plays.] "Bandsmen, play nicely! Go on, do just as I want you to!"*

Sound also plays an important role in the conclusion of the drama, as it symbolizes dying, the death of everything that previously existed; only silence remains. *"It is quiet. Then the sound of an axe against the trees is heard in the silence, sad and solitary."* Such a sound appears already in the second act as a harbinger of the coming disaster. This sound is "like a breaking string"; the instrument can then no longer play and the song is finished, the drama ending with these words: *"The distant sound is heard, as if from the sky, of a breaking string, dying away sadly. Silence follows it, and only the sound is heard, some way away in the orchard, of the axe falling on the trees."*

Music also accompanies the action in other Chekhov dramas and novellas. In *The Three Sisters*, behind the stage and on it, different music can be heard: brother Andrei is playing the violin; street music: *"Somebody is heard playing a concertina outside in the street"*; soft singing and guitar playing in the hall; the baron is playing a waltz; people sing a Russian folk song *"Oh my house, my house, my new-built house"*; we can hear the nanny singing; *"a concertina is being played in the street. The nurse sings."*; Vershinin, the man who bought the estate, sings Gremin's aria from Tchaikovsky's *Eugene Onegin*, *"The power of love all ages know, From its assaults great good does grow"*; *"The Maiden's Prayer"* is being played on a piano



in the house." This is a work by Tekla Badarzewska-Baranowska, a Polish romantic composer very popular in the second half of the nineteenth century, which was also mentioned in the works of many different writers. (Maiorova 2014) "Somewhere a harp and violin are being played"; "two wandering musicians, a man and a girl, are playing on a violin and a harp"; "a march is played off; they all listen"; an army doctor is reading a newspaper, singing softly; at the end of the play, behind the stage the band plays, after which "the music grows softer and softer".

10. Memories of Italy

Like other Russian writers, such as Turgenev and Gogol, Chekhov travelled to Italy, including Venice, and was fascinated by the beauty of this country.

In the story *Ariadne*, the title character wants to travel to Italy, and the narrator's father "began telling us at length about Italy, how splendid it was there, the exquisite scenery, the museums."

In *The Story of an Unknown Man*, the hero Gruzin remembers Turgenev's *Three Encounters* and the passage when, late in the evening, the protagonist hears the song 'Vieni pensando a me segretamente'. With this, he is ironizing Turgenev's heroes, who are helped in their heroic roles by noble and honest girls who accompany them to the end of the world to serve their ideas.

In *The Story of an Unknown Man*, the first-person narrator, an "unknown man" (named Vladimir Ivanich), who suffers from tuberculosis, goes to Venice (just like the sick Insarov and Elena in Turgenev's story *On the Eve*), except that in Chekhov's story the hero is accompanying a deceived woman. Chekhov enthusiastically writes also about the beauty of Venice through the eyes of a hero observing the city from a balcony. The sight of a sunlit city by the sea infuses the hero with new strength: "The sunshine and the breeze from the sea caressed and fondled my sick body. I looked down at the familiar gondolas, which glide with feminine grace smoothly and majestically as though they were alive, and felt all the luxury of this original, fascinating civilisation. There was a smell of the sea. Someone was playing a stringed instrument and two voices were singing. How delightful it was."

Even in the evening, the maritime panorama is accompanied by music in the background: "Not far from us in a gondola, hung with coloured lanterns reflected in the water, there were people singing. The sounds of guitars, of violins, of mandolins, of men's and women's voices, were audible in the dark." The lively, vibrant atmosphere of an evening in Venice is in complete contrast to the emotional state of the female protagonist: "[...] around her the gondolas, the lights, the music, the song with its vigorous passionate cry of "Jam-mo! Jam-mo!" — what contrasts in life!" The melody mentioned is the well-known Neapolitan 'Funiculì, funiculà', written by Luigi Denza in 1880 to a text by Peppino Turco on the occasion of the opening of the funicular railway to Mount Vesuvius (Wikipedia).

Conclusion

In the works of Chekhov, music accompanies a person from the cradle to the grave. In childhood, nurses play an important role, singing lullabies (*The Cherry Orchard*, *The Three Sisters*). A band accompanies a person on his last journey (at the beginning of *The Three Sisters*). Music is present at all important moments in life, such as weddings, when they sing in church (*The Shooting Party*). Music accompanies people in their everyday life. With a quote from a song or composition, Chekhov completes his description of the emotional state of his heroes: when they are happy, they sing (like Ionitch in the story of the same name), express sadness (in *The Cherry Orchard*, Epikhodov always plays "the same sad song on the guitar"); music emphasizes dullness (as in *Ariadne*, in a boring city where nothing happens, the band always plays the same, monotonous tune), or, on the contrary, music helps to put people in a good mood (*Anna on the Neck*). Music evokes the memory of past, happy years (*Ionitch*). The presence of an orchestra is an indispensable part of parties and



dances, when the heroes dance quadrilles, waltzes and other dances. Street music and musicians in parks are also mentioned several times. Even the heroes themselves play a musical instrument, such as the piano, guitar or violin, and sing. They discuss music and attend concerts and opera performances (*The Lady with the Dog*). In Chekhov's dramas, music accompanies the action on stage. By the use of sound, the writer vividly foretells disaster, the decline of Russian noble families, the sale of estates and the beginning of a new era (the dying sound "as if a string were being broken" in *The Cherry Orchard*).

In Chekhov's work, we find many quotations of verses from folk songs and Russian ballads, as well as titles of compositions of classical music. There are many references to the compositions of Tchaikovsky, whom the writer also met personally, and the two artists were connected by admiration for each other's work. Chekhov's work, however, even comprises stories with purely musical titles.

References

1. Aškerc A. 1898. Jakov Petrovič Polonskij. Ljubljanski zvon, year 18, n. 12. Internet source: <https://www.dlib.si/details/URN:NBN:SI:doc-LYVZ3WWN>. Accessed: 21. 10. 2022.
2. Chekhov A. Anna on the Neck. Internet source: <https://www.livrosgratis.com.br/ler-livro-online-84623/anna-on-the-neck>. Accessed: 15. 11. 2022.
3. Chekhov A. A Nervous Breakdown. Internet source: https://www.gutenberg.org/cache/epub/57333/pg57333-images.html#Hlink2H_4_0001. Accessed: 15. 11. 2022.
4. Chekhov A. Ariadne. Internet source: <https://www.livrosgratis.com.br/ler-livro-online-86740/ariadne>. Accessed: 15. 11. 2022.
5. Chekhov, A. A Tedious Story. Internet source: https://www.gutenberg.org/cache/epub/57333/pg57333-images.html#A_TEDIOUS_STORY. Accessed: 16. 11. 2022.
6. Chekhov A. 2000-2022. Ionitch. Internet source: http://www.online-literature.com/anton_chekhov/1292/. Accessed: 14. 11. 2022.
7. Chekhov A. 2000-2022. My life. Internet source: http://www.online-literature.com/anton_chekhov/1284/. Accessed: 14. 11. 2022.
8. Chekhov A. On the Harmful Effects of Tobacco. Internet source: <https://docplayer.net/21077214-On-the-harmful-effects-of-tobacco-1902-anton-chekhov.html>. Accessed: 15. 11. 2022.
9. Chekhov, A. Story of an Unknown Man. <https://linguabooster.com/en/en/book/story-of-an-unknown-man#page-14>. Accessed: 16. 11. 2022.
10. Chekhov A. 2000-2022. The Anniversary. Internet source: http://www.online-literature.com/anton_chekhov/the-anniversary/1/. Accessed: 14. 11. 2022.
11. Chekhov A. 2016. The Cherry Orchard. Internet source: https://www.gutenberg.org/files/7986/7986-h/7986-h.htm#link2H_4_0014. Accessed: 18. 11. 2022.
12. Chekhov A. The Shooting Party. Internet source: <https://archive.org/details/in.ernet.dli.2015.113388/page/n99/mode/2up?q=church&view=theater>. Accessed: 16. 11. 2022.
13. Chekhov A. 2000-2022. The Three Sisters. Internet source: https://www.online-literature.com/anton_chekhov/three-sisters/. Accessed: 14. 11. 2022.
14. Chekhov A. 2012. Uncle Vanya. Gutenberg eBook. Internet source: <https://www.gutenberg.org/files/1756/1756-h/1756-h.htm>. Accessed: 14. 11. 2022.
15. Chekhov A. Three Years. Internet source: <https://www.livrosgratis.com.br/ler-livro-online-150397/three-years>. Accessed: 15. 11. 2022.
16. Čehov A. 1947. Izbrano delo I. Dramska dela. Prevedli Avgust Pirjevec, Josip Vidmar, Ivan Prijatelj, Janko Moder. Ljubljana: DZS.
17. Čeredničenko T. V. Цыганский романс. Internet source: <https://www.belcanto.ru/cygansky.html>. Accessed: 4. 10. 2022.
18. Černyšov S. 29. 1. 2021. Russian Calendar with Stanislav: January 29th, Anton Chekhov. Internet source: <https://www.youtube.com/watch?v=91su42CML6w>. Accessed: 8. 8. 2022.
19. Delvig A. Wikipedia. Internet source: https://en.wikipedia.org/wiki/Anton_Delvig (accessed on 4. 11. 2022).
20. Ekaterina Gudkova. Музыка в русской литературе. Культура.РФ. Internet source: <https://www.culture.ru/materials/254490/muzyka-v-russkoi-literature>. Accessed: 8. 8. 2022.
21. John Field. Wikipedia. Internet source: [https://en.wikipedia.org/wiki/John_Field_\(composer\)](https://en.wikipedia.org/wiki/John_Field_(composer)). Accessed: 17. 10. 2022.
22. Funiculi, funiculà. Wikipedia. Internet source: https://it.wikipedia.org/wiki/Funicul%C3%AC_funicul%C3%A0. Accessed: 8. 8. 2022.



23. Kennedy, Michael in Joyce Bourne. 1996. The Concise Oxford Dictionary of Music. Oxford: Oxford University Press.
24. Lezgins. Wikipedia. Internet source: <https://en.wikipedia.org/wiki/Lezgins> . Accessed: 24. 10. 2022.
25. Maiorova. 2014. Всем хитам хит. Internet source: <https://maiorova.livejournal.com/385111.html>. Accessed: 28. 10. 2022.
26. Operetta. VII. Переводы В. Крылова и В. Курочкина и формирование русской сценической традиции. Internet source: http://sunny-genre.narod.ru/books/yankovsky_1937/3-7.html. Accessed: 20. 10. 2022.
27. Чайковский и Чехов. Internet source: <http://www.antonchehov.ru/4aikovskii/> Accessed: 9. 8. 2022.
28. Чехов и Чайковский: история одной встречи. «Музей – усадьба П.И.Чайковского». 2022. Internet source: <https://tchaikovskyhome.ru/photoalbums/chehov-i-chaikovskii-istoriya-odnoi-vstrechi>. Accessed: 9. 8. 2022.
29. Чехов. 2010. Рассказы. Юморески. Драма на охоте. 1884-1885. Книга 3. Москва: Директ-Медиа. Internet source: <https://books.google.si/books?id=ALuNefmsLkgC&pg=PA86&lpg=PA86&dq=%D0%B1%D0%B5%D0%B7%D1%83%D0%BC%D0%BD%D1%8B%D0%B5+%D0%BD%D0%BE%D1%87%D0%B8+%D0%B2%D0%B5%D1%81%D1%91%D0%BB%D1%8B%D0%B5+%D0%BD%D0%BE%D1%87%D0%B8&source=bl&ots=5085LviTIC&sig=ACfU3U1uCEImX8Inbb3-wenJ0a1tETLOQQ&hl=sl&sa=X&ved=2ahUKEwil6t3cqcb6AhWwQvEDHRFXB90Q6AF6BAgVEAI#v=onepage&q=%D0%B1%D0%B5%D0%B7%D1%83%D0%BC%D0%BD%D1%8B%D0%B5%20%D0%BD%D0%BE%D1%87%D0%B8%20%D0%B2%D0%B5%D1%81%D1%91%D0%BB%D1%8B%D0%B5%20%D0%BD%D0%BE%D1%87%D0%B8&f=false> (accessed on 5. 10. 2022).

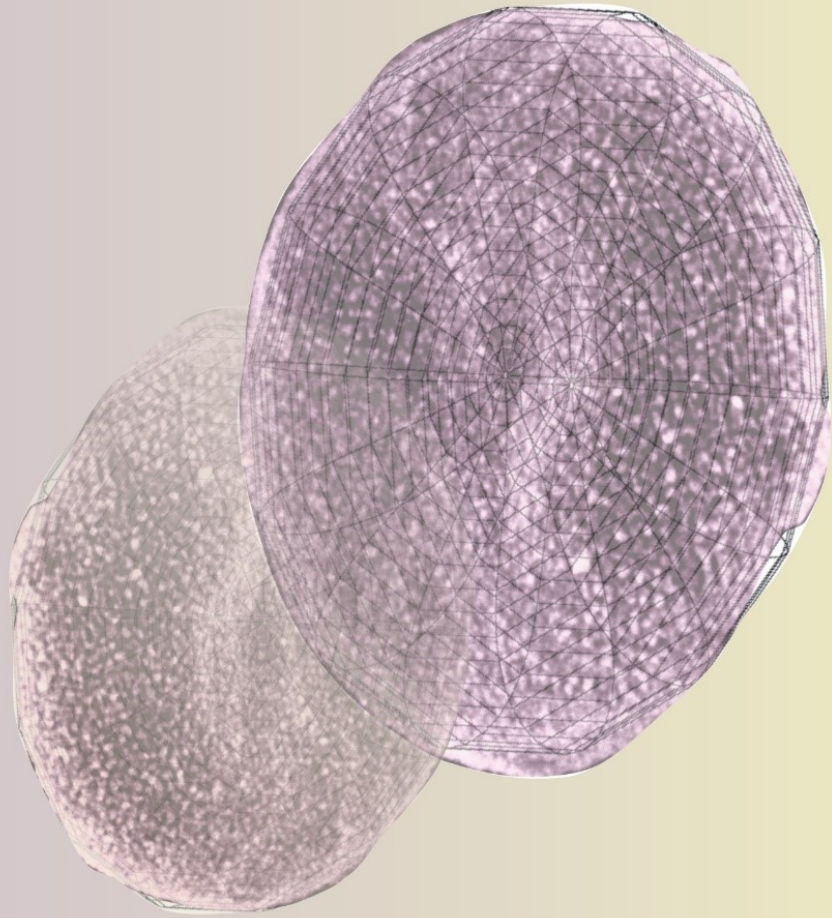



Scientific contribution

Accreditation and Rankings of Universities: Theory of Global Accreditation in the World of (Dis)Order

Istileulova Yelena^{1,2,*}

1. KEN (Knowledge Economy Network), Slovenia;

2. FIBAA External Project Manager (Germany); DAAD Bologna Hub Peer Support project (Bonn-Brussels);

* Correspondence: Yelena Istileulova, yelena.istileulova@gmail.com

Abstract:

At the beginning of the third decade, the time of great uncertainties and disorder, higher education institutions re-discovered that accreditation and rankings serve as the visibility mechanisms to attract students, partners and stakeholders. The goal of this paper is threefold: to introduce the Theory of Global Accreditation (TGA) for different organisations (universities, firms, and business schools), to illustrate changes which take place as a result of accreditation practices and to reflect some trends in the market of global education with different accreditation and ranking schemes. Although the word 'Accreditation' is used from 1535, the accreditation trends became the new "political" phenomenon in the 21st century. The paper answers the questions: why and how do organisations seek the international accreditations and what are their impacts. The explanation of an observed phenomenon is helpful in a new world disorder filled with crises in multiple fields, and TGA can answer some practical questions of different academic and business organisations as well as different stakeholders as well as facilitate in predicting and grasping the level of expected changes. The examples of accreditation practices are provided for the global business education and in the European Higher Education Area, in line with rankings with the explanation how they become an 'accelerator' of higher education reforms with the growing impact on the landscape of higher education. It is also perceived that international accreditation and rankings agencies can expand their services becoming the potential areas for consulting, research and science diplomacy in the new world of global disorder.

Keywords: Accreditation; Quality Assurance (QA); Rankings; Theory of Global Accreditation; Globalisation; Organisational and Institutional Change;

Citation: Istileulova Y. Accreditation and rankings of Universities: theory of global accreditation in the world of (Dis)Order. Proceedings of Socratic Lectures. 2023, 8; 168-176.

<https://doi.org/10.55295/PSL.2023.II21>

Publisher's Note: UL ZF stays neutral with regard to jurisdictional claims published maps and institutional affiliations.



Copyright: © 2023 by the author. Submitted for possible open access publication under the terms and conditions of the Creative Commons Attribution (CC BY) license (<https://creativecommons.org/licenses/by/4.0/>).



1. Introduction

1.1. On International Accreditation and Rankings in higher education: 21st century

At the beginning of the 21st century, Van Damme (2001) justified the need for a new regulatory framework for quality assurance (QA) and accreditation mechanisms within the force of globalisation depending on universities' regional location in the world. By that time, it was clear that globalisation with its economic, political, and societal forces should be linked to the scientific community, the Internet, the worldwide inequality with McDonaldisation of universities and other factors, with accreditation schemes moving beyond national agencies towards being internationalized and commercialized (Altbach, 2004; 2007).

From the 2020s, the world has been changing at an ever-faster pace with its rapid digital communication patterns imposed by Covid-19 to universities and businesses. In addition to the ecological crisis, the time of great uncertainties in many areas of life, the time of a global (dis)order with the changing markets and the new challenges for higher education set the scene for 2023. Within the time of great uncertainties, HEIs also "re-discovered" that accreditation and rankings might serve as the visibility mechanisms to attract more students, partners and stakeholders. On the other hand, HEIs could get themselves on the international map and benchmark on best practice as a tool for comparison.

The term "**accreditation**" is "a form of quality assessment where the outcome is a binary (yes/no) decision that involves the granting of special status to an institution or programme" according to OECD (2009). The distinctive characteristic of accreditation with various "Quality seals" compared to other QA models is the involvement of external partners - stakeholders with a specific interest in the quality of education provided (governments, associations, employers or professional bodies). The international accreditation refers more to value and organisational culture: "Societal culture and the apparent imposition of 'Western' neoliberal educational and management values onto the rest of the world must also be considered" (Collins, 2015). It is awarded after an in-depth analysis of an institution and aims to establish: whether (a) its objectives are appropriate, (b) plans are suitable to achieve its objectives; (c) actions conform with the plans and (d) whether they are effective (Marconi, 2013). International accreditation allows universities to shift its position ahead in their order of rankings, climbing to the upper place on this ladder. In the light of the quickly changing accreditation market, where The Economist and Forbes' rankings are disappearing, it is important to understand a role of organisation (business-school, university, etc.) in "accreditation club": who it is (DNA), where it is coming from (history), where it is going (strategy), what it wants to achieve (transformation) vs. other members of club (Kahn, 2023).

Accreditations and rankings are both signal the quality of the services offered by a university, but they work differently. Formal quality assurance comes in the form of accreditation, quality audit, and quality assessment (Hoffman, 2013). Whereas accreditation and QA have been used as transparency instruments mostly on the initiative of governments, university rankings have appeared as a result of private initiatives (Jongbloed et al., 2018). Unlike accreditations which combine self-evaluation reports, physical or online peer visits with involvement of different organisational units of organisation, rankings publish annual results, more accessible: they do not require special efforts from the organisation in terms of resources. Despite criticism, rankings are becoming an 'accelerator' of higher education reforms, the international measure of quality with the growing impact on landscape of higher education, geopolitical positioning of nations/universities in terms of building a shared sense of societal purpose and identity (Hazelkorn, 2017).

2. Materials and Methods: Theory of Global Accreditation (TGA)

2.1. Materials

Word 'Accreditation' is used from the year of 1535, originating from a Latin 'accredere' (give credence to). In its modern meaning, the broad meaning of accreditation remains as it was in the 16th century. In terms of business education, accreditation is the process by which an academic programme holds itself out for review by an external organisation, to



be measured against a set of predetermined standards. The theory of Global Accreditation (TGA) (Istileulova, 2018) was developed on the examples of business schools (independent Economic Universities/structures) with the institutional top-accreditations (institutional AACSB-EFMD), and briefly presented below. It explains the phenomenon of international accreditation from the economic perspectives and interprets why and how the organisation (which applies for accreditation seal) behaves, especially in the time of great uncertainty (global disorder). In addition to its explanation how organisations behave during the international accreditation practices, the TGA also predicts the general trends that take place on the related market of higher education.

The Theory of Global Accreditation (TGA) addresses the following research questions (RQ): Why and how do organisations (universities/business schools/firms) seek the international accreditations and what are the impacts of accreditation practices? Based on the qualitative and quantitative analysis of five case studies of top-accredited business schools (with AACSB and EFMD accreditations) and the institutional theory's framework, the following answers to the listed RQ are provided:

1. Organisations (universities/business schools, etc.) seek international accreditation due to the legitimacy practices (RQ: Why?);
2. Organisations take the accreditation either as a business opportunity or follow the suggestions of the formal leader (agent of change) (RQ: How?);
3. During the accreditation phase, organisations undergo the key isomorphic change (linked to *organisational values*): **mimetic, normative, coercive changes** (RQ: What are the impacts?).
4. If the brand of international accreditation is strong, organisation with the acquired accreditation sends the additional strong signals to their rivals with the information asymmetry and bandwagon trends (RQ: What are the impacts?). Bandwagon trends are a 'domino' effect, when there is no assessment of innovation (in this case - accreditation), just its adoption (Secchi & Bardone, 2013).

Organisational change can take place without bandwagon or information asymmetry effects in the case of the first-mover (in the local/national/regional market). Organisational change turns into the institutional change under the following conditions: (i) practices of accreditation are being spread across the professional fields; (ii) other organisations in local/regional markets copy this practice through competitive bandwagon trends (with a domino/virus effects) among professional organisations.

Thus, both organizational and institutional change occur through, at least, three mechanisms of coercive, normative, and mimetic isomorphism according to DiMaggio and Powell (1983, p. 150): coercive isomorphism is a result of political influence; mimetic one - as a standard response by imitation; and normative one - as a result of professionalization. In the time of globalization (uncertainty, and disorder), there are more obvious processes with information asymmetry's reduction (with Quality label) and bandwagon trends (differently from mimetic trend, where there are some attempts to assess it). The TGA was developed based on the analysis of materials (interviews and surveys) of business schools from the Central and Eastern Europe (Croatia, Poland, Slovenia and Russia) with the top-awarded international accreditations with the Quality Seals from AACSB and EFMD as well as their competitors/rivals, and the potential employers. The institutional theory was applied as a main theoretical framework. In addition, the round of interviews/surveys of three top business schools from the Baltic state (Lithuania) and one top-business school from Central Asia (Kazakhstan) with few accreditations were collected and analysed. In addition to PhD courses, the author took special courses on a Theory development course in 2015 from Arun Rai (US), Regents' Professor of the University System of Georgia, the Howard S. Starks Distinguished Chair at the Robinson College of Business at Georgia State University and the course on Qualitative methods in EIASM (European Institute for Advanced Studies in Management) from Anne Kovalainen, Päivi Eriksson (Finland), and Da-



vid Silverman (UK). The Russian, East European, and Eurasian Center (REEEC) at the University of Illinois, supported research through a provision to the library access during the researcher's visit in 2012.

2.1 Method: Theory of Global Accreditation (TGA) in the time of global disorder

The TGA (2018) can be turned into a method to apply its mode of observation: a theory becomes also as a research method to treat itself as an object of observation. In addition to its explanation (above), the TGA also predicts the following trends in the time of global uncertainties (disorder) which are manifested through the following observations:

1. Isomorphic effects of organisations with the international accreditations are becoming more evident as the pathway towards the national, international legitimacy;
2. The competitive rivals catch up accredited organisations by applying for the same or similar accreditation practices; Therefore, to meet this demand, there will be a growing supply with various accreditation schemes and rankings;
3. The younger the organisation/institution, the greater the degree of change in its initial accreditation practices;
4. The greater the number of institutional top-accreditations, the higher the degree of organisational change;
5. The process of acquiring the first international accreditation is an expected legitimacy of local/national market, two accreditations - international market and the triple as well as the multiple accreditations serve for power and legitimacy, where each additional accreditation and reaccreditation speed up the initial level of change;
6. In the case of first-movers with accreditation practice, the initial bandwagon or information asymmetry might be missing, however, other isomorphic changes are present;
7. The institutional change takes place in the local market at the time, when competitive organisation start reproducing the analogous accreditation practices with a bandwagon;

The institutional theory is a theoretical underpinning for the Theory of Global Accreditation (TGA) which can be applied for different regions and countries for QA practices (accreditations – in education/Total Quality Management (TQM)- in business). Any accreditation serves as a useful starting point to offer value as a reference for comparison between several choices. The accreditation status (depending on accreditation body) always influences (to a certain degree) the positions in university ranking.

3. Results and Discussion: accreditation and rankings as quality differentiators

Zammuto (2008) predicted two trends with the growth of for-profit universities and the globalisation of higher and business education with the diffusion of accreditation as a quality differentiator. In addition to the accreditation assessment criteria, values, roles, processes, costs, there is also a certain influence of each accreditation. Elliott and Goh (2013) note, accreditation is a pervasive global trend with its influence in other countries.

As far as the business education is concerned, there are three **main accreditation bodies** with the global recognition levels known as "triple-accredited" (AACSB-EFMD-AMBA). It is considered that even one of these international accreditations provides the assurance of high quality for a management or management programme. Association to Advance Collegiate Schools of Business (AACSB), the American agency is over 100 years old, it is widely recognised as an elite business school accreditation, despite losing its recognition by the Council for Higher Education Accreditation in 2016 (Hawes, 2017). The British Association of MBAs (AMBA) focuses on accreditations of schools with MBA programmes. The European Quality Improvement System (EQUIS) was launched by EFMD only in 1999 when the challenge of creating a European market for higher education was first on the

political agenda (Shenton, 2010). **Figure 1** indicates not only the potential accredited members, but the potential growth of EFMD as the global body with global trends; **Figure 2** – current number of accredited HEIs in the 1st quarter of 2023.



Figure 1. List of EFMD members, 2023. Source: <https://www.efmdglobal.org/#>;



Figure 2. Number of accredited b-schools, 2023. Source: <https://www.efmdglobal.org/accreditations/business-schools/equis/>

If we understand the concept of ‘global disorder’ by giving it definition as a disruption of norms, rules and behaviour on a global scale, in this sense, the demonstrated trends with EFMD (as an example of global body) would be a contradiction: they show a predictable process with the objective demand and growth of accreditation schemes on a global scale. Therefore, it is perceived as a certain order, with the expected trends explained and presented by TGA for the local and regional markets with their organisations.

In most European countries, HEIs or study programmes are subject to regular external review by a quality assurance (QA) agency. The European Higher Education Area (EHEA) was launched in March 2010, on the 10th anniversary of the Bologna Process with the objectives to promote the mobility of students and staff, the employability of graduates and the European dimension in higher education, with a common QA system. A major challenge was the external evaluation in 2010/11 by the European Quality Assurance Register for Higher Education (EQAR), the official register of agencies in EHEA which publishes a list of credible QA agencies to reduce chances for disreputable providers - ‘accreditation mills’ – to gain credibility. Figures 3 and 4 also illustrate the growth and possible competitive rivals (ii. point above, in 2.1.), evolution of EHEA’s accreditation bodies with its growing accreditation schemes is presented in **Figures 3** and **4** in 2023.



Figure 3 includes the list of accreditation bodies with 3 leaders in EHEA, all with their offices in Germany. Cross border QA activities within the EHEA mostly carried out within countries that have a legal framework recognising foreign EQAR-registered agencies. The number of international accreditations has sharply jumped within this year – this trend with Cross-Border QA schemes can be seen in Figure 4. At the same time, it should be noted that enhancing the quality, one of the key goals of the Bologna process, remains uneven across the 48 participating EHEA countries.

Cross-border external QA by no. of countries & HEIs

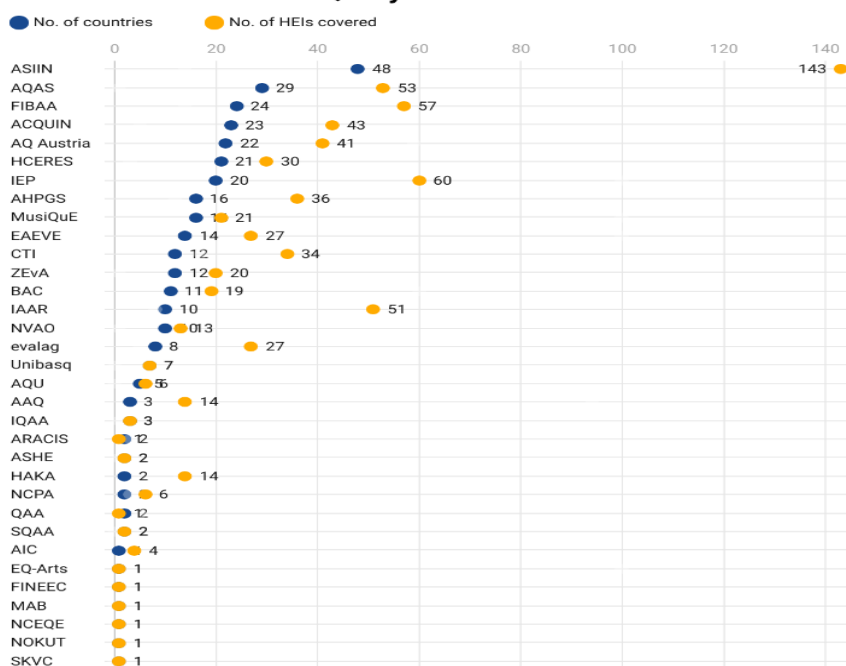

Figure 3. Stats on cross-border QA (March, 2023). Source: EQAR, 2023, accessed 31 March 2023 <https://www.eqar.eu/kb/cross-border-qa/drafting-cross-border-external-qa-activities/>

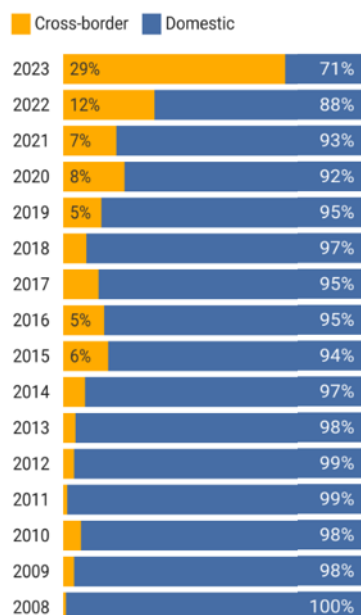

Figure 4. Share of cross-border QA (March, 2023). Source: Database of EQAR, 2023, accessed 31 March 2023 <https://www.eqar.eu/kb/cross-border-qa/drafting-cross-border-external-qa-activities/>



3.2 International Rankings

There are now more than 20 university ranking organizations with a global focus, and even more with a regional or discipline-specific rankings, and each ranking has its niche, data sources, methodology, and indicator (Elsevier, 2021). Universities use rankings for visibility purposes as well as to define their performance, professional reputation and status, whilst students use them to choose their future place of study and research (EHEA, 2015). The general criticism rankings include the following general statements: 1. they are not objectives as appear; 2. they suffer from integrity issues; 3. they're tilted toward the best-known HEIs (universities/business-schools); 4. they follow different methodologies; 5. they do not effectively measure the important key factors (most of the rankings do not effectively measure areas of increasing importance to prospective students, such as societal change) (AACSB, 2022). At the same time, with the processes of globalisation and internationalisation of universities, the concept of university rankings became the important tools used by academics, students, parents, researchers, potential faculty members, funders, and other stakeholders seeking an information on university's performance. Rankings is a very popular tool in Global Asia. The popularity of this tool is well reflected in the neologism "glocalization, the reflection of interdependence of the global and the local, as Jung (2010) wrote: "the global without the local is empty and the local without the global is myopic".

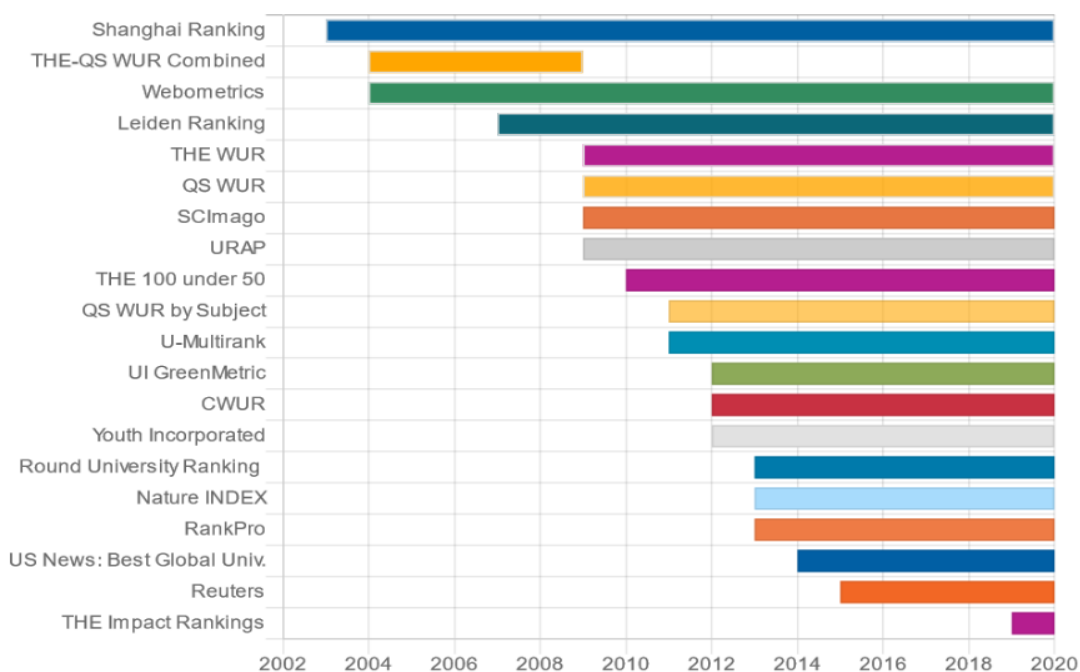

Figure 5. International ranking organizations, their establishment and growth. Source: Elsevier (August 10, 2021)

Shanghai Ranking or the Academic Ranking of World Universities (ARWU), is regarded as one of the three most influential university rankings, alongside QS World University Rankings and Times Higher Education (THE) World University Rankings. Universities need to decide which factors are most important in their selection process to meet their missions and objectives to choose the ranking system that best reflects their specific purposes to get the most accurate comparison for their needs.



4. Conclusions

The accreditation and ranking schemes are becoming an 'accelerators' of educational reforms, with the growing impact on the landscape of higher education for geopolitical positioning of universities or even nations in terms of building or rebuilding a shared sense of societal purpose and identity. The process takes place according to the Theory of Global Accreditation which answers the questions why and how universities or organisations are involved in this process and the types of changes occur at the level of organisation or institutional markets. Universities might see the example of good practices, but also to check whether their reputation depends on the perception of accreditation and rankings as well as arbitrary opinions, stakeholders and various external signals. Signalling mechanisms (which still have to be explored in more details for accreditation schemes) can be a continuation of this paper. Universities need to decide which factors are most important in their selection process to meet their missions and objectives to choose the accreditation and ranking systems that better reflect their specific purposes to get the most accurate comparison for their needs. The author of paper thinks that there is a great potential for both accreditation and ranking agencies of using the cooperation schemes in higher and business education with the future research, science and consulting services. The promotion of science diplomacy in the EHEA and beyond to gain good scientific results in the area of academic and research interdisciplinary fields might be embedded as the new area of activities for the growing accreditation agencies in this new world of global disorder.

Funding: The research was conducted independently from any funded-related institutions or organisations, where the main part related to TGA was conducted on the own funds of the author during her PhD studies and visits to five business schools from Slovenia, Croatia, Poland and Russia.

Conflicts of Interest: The author declares no conflict of interest.

References

1. AACSB- Association to Advance Collegiate Schools of Business: 5 Things Business School Rankings Don't Tell You. (June 8, 2022). Available from: <https://www.aacsb.edu/insights/articles/2022/06/5-things-business-school-rankings-dont-tell-you>
2. Altbach PG. Globalisation and the university: Myths and realities in an unequal world. *Tertiary Education and Management*. 2004; 10: 3-25. DOI: 10.1023/B:TEAM.0000012239.55136.4b
3. Altbach PG, Knight J. The internationalization of higher education: Motivations and realities. *Journal of Studies in International Education*. 2007; 11: 290-305. DOI: 10.1177/1028315307303542
4. Collins I. Using international accreditation in higher education to effect changes in organisational culture: A case study from a Turkish university. *Journal of Research In International Education*. 2015; 14: 41. DOI:10.1177/1475240915592589
5. EHEA, 2015. The 7th Annual International Symposium on University Rankings and Quality Assurance 2015. Available from: <https://www.svu.edu.eg/en/2015/05/13/the-7th-annual-international-symposium-on-university-rankings-and-quality-assurance-2015/>
6. Elliott CJ, Goh SC. Does accreditation promote organizational learning? A multiple case study of canadian university business schools. *J. Manag. Dev.* 2013; 32: 737-755. DOI:10.1108/JMD-03-2011-0028
7. Elsevier 2021. University Rankings. Closer look for research leaders. Available from: <https://www.elsevier.com/research-intelligence/university-rankings-guide>
8. EQAR. Cross-border external QA activities. Access 01 March 2023. Available from: <https://www.eqar.eu/kb/cross-border-qa/drafting-cross-border-external-qa-activities/>
9. Hawes K. Business School Rankings and Accreditations: How to Use Them. Access Masters. Access 7 february 2017. Available from: <https://www.accessmasterstour.com/articles/view/business-school-rankings-and-accreditations-how-to-use-them>
10. Hazelkorn E. Rankings and higher education: Reframing relationships within and between states. Centre for Global Higher Education. 2017. Working Paper 19. Available from: <https://www.researchcghe.org/publications/working-paper/rankings-and-higher-education-reframing-relationships-within-and-between-states/>
11. Hoffman E. Ratings, Quality, and Accreditation: Policy Implications for Educational Communications and Technology Programs in a Digital Age. *Tech Trends*. 2013; 57: 47-54. DOI:10.1007/s11528-013-0691-8
12. Istileulova Y. The effects of international accreditation on institutional changes of business schools: doctoral dissertation. Univerza v Ljubljani, 2018. <http://www.cek.ef.uni-lj.si/doktor/istileulova.pdf>.



13. Jongbloed B, Vossensteyn H, van Vught F, Westerheijden DF. (2018). Research Handbook on Quality, Performance and Accountability in Higher Education. Edward Elgar Publishing. 2018; pp. 560-574.
14. Jung, H. Y. And What 'Global Asia' Means in an Age of Hyphens and Hybrids. *Global Asia*. 2010; 5: 88-97.
15. Kahn D, Kjellander B, Stevenin B. Building reputation through quality management of accreditations and ranking. Access 20.3. 2023. Available from: <https://www.globalfocusmagazine.com/building-reputation-through-quality-management-of-accreditations-and-ranking/>
16. Marconi G. Rankings, accreditations, and international exchange students. *IZA Journal of European Labor Studies*. 2013; 2: 1-22. DOI: 10.1186/2193-9012-2-5
17. OECD (2009), Higher Education to 2030, Volume 2, Globalisation, OECD Publishing, Paris, pp 324. Available from: <https://www.oecd.org/education/cei/highereducationto2030volume2globalisation.htm>
18. Secchi D, Bardone E. Socially distributed cognition and intra-organizational bandwagon: Theoretical framework, model, and simulation. *Int J Organ Theory Behav*. 2013; 16: 521-572. DOI:10.1108/IJOTB-16-04-2013-B004
19. Shenton G. Credit when it's due. Focus on AACSB and EQUIS. *Global Focus*. 2010; 4: 20-24. Available from: <https://issuu.com/efmd/docs/global-focus-vol-04-issue-01>
20. Zammuto RF. Accreditation and the Globalization of Business. *AMLE*. 2008; 7: 256. DOI: 10.5465/AMLE.2008.32712623

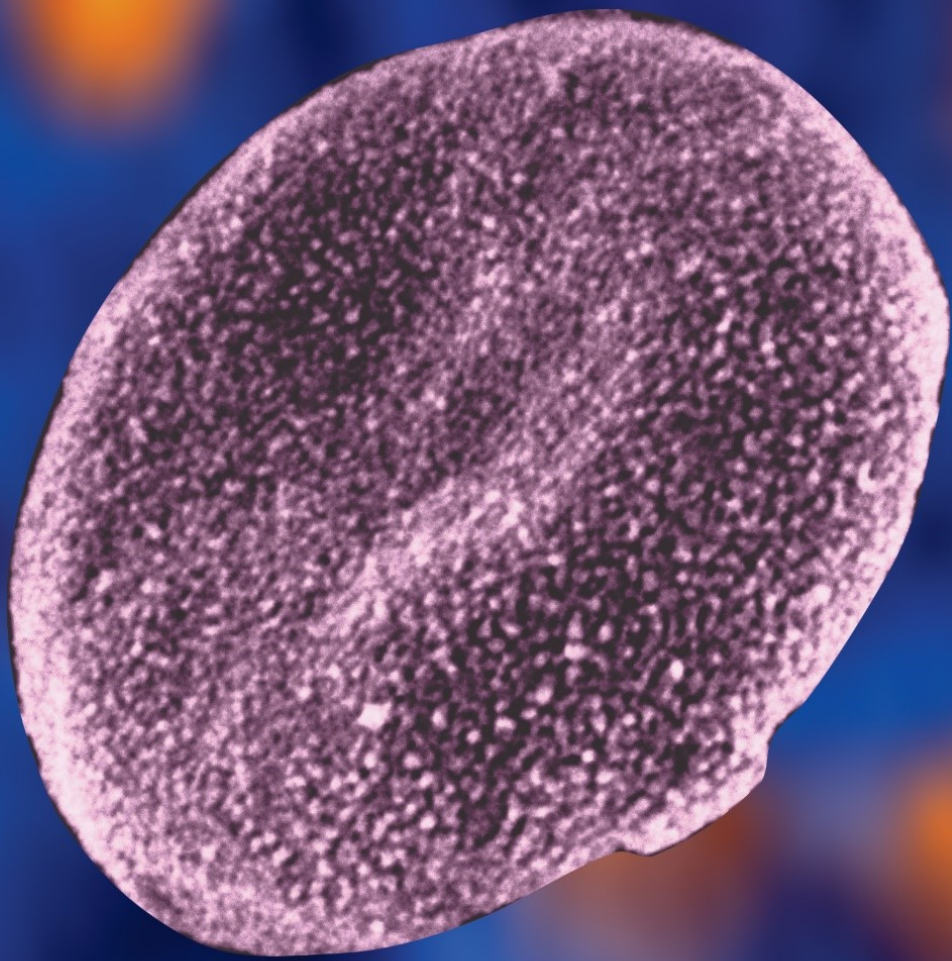



Invited lecture/Reflection

Interdisciplinary Cooperation and Education at Charité Universitätsmedizin Berlin

Kocjančič Ema¹, Travnik Tina², Kocjančič Boštjan^{1,3}

1. University of Ljubljana, Faculty of Medicine
2. University of Ljubljana, Biotechnical Faculty
3. Ljubljana University Medical Centre, Department of Orthopaedic Surgery

* Correspondence: ema.kocjancic17@gmail.com

Abstract

This report includes the written experience and reflection of a physician and two students from different faculties of the University of Ljubljana. Within the observatorship programme, we took part at the renowned medical clinic Charité Universitätsmedizin Berlin (Charité). Our stay has familiarised us with several campuses of hospitals and institutions, all taking part of Charité. Within the scope of the observatorship, we got to know several medical professionals from different fields, we were able to observe their work, ethics and their approach to treating patients in outpatient clinics and in intensive care units. Additionally, we were presented with the clinical research conducted by many researchers in Charité's laboratories. The experience of observing work and research at Charité has thus helped broaden our horizons, make new long-lasting international connections and introduced us to a new, different world of knowledge previously unfamiliar to us.

Citation: Kocjančič E, Travnik T, Kocjančič B. Interdisciplinary Cooperation and Education At Charité University Medicine Berlin . Proceedings of Socratic Lectures. 2023, 8; 178-185. <https://doi.org/10.55295/PSL.2023.II22>

Publisher's Note: UL ZF stays neutral with regard to jurisdictional claims in published maps and institutional affiliations.



Copyright: © 2023 by the authors. Submitted for possible open access publication under the terms and conditions of the Creative Commons Attribution (CC BY) license (<https://creativecommons.org/licenses/by/4.0/>).

Keywords: Observatorship; Interdisciplinary cooperation; Research; Student; Charité.



1. Introduction

The article is organized in four parts: the first part reports the experiences of the authors in organizing and staying at Charité Universitätsmedizin Berlin (Charité). The second part includes a report of the first author (E.K.), a 1st year student of general medicine at University of Ljubljana, Faculty of Medicine and observations of the third author (B.K.), an orthopaedic surgeon. The third part includes a report of the second author (T.T.), a 2nd year student of biology at University of Ljubljana, Biotechnical Faculty. The fourth part includes data on the organization of Charité and on its history.

2. A Visit to Charité

The visit to Charité took place due to the contact of the authors with professor Andrej Trampuž, the Head of the Musculoskeletal Infections and Research Department at the Charité. Professor Trampuž started his medical career at the Faculty of Medicine of the University of Ljubljana, continued his medical career at the Mayo Clinic in the United States, later moved to Switzerland, and since 2013, he has been employed in Berlin. The first discussions about a visit to Charité for professional training of B.K., so called observatorship, started over two years before the visit. At that time, E.K. and T.T. have already chosen their studies and future professions and were delighted to be included in the visit to this distinguished institution. The most intensive discussions and the planning of the three-month observatorship started roughly a year before we left for Berlin. There, professor Trampuž invited us to visit him and observe his infectious diseases research department in Charité to get an impression on the work and ethical conduct taking place in Charité.

Prior to our departure, we were informed by the Charité officers that E.K. and T.T. would be observing and shadowing the work of the medical staff and Professor Trampuž. B.K. would be able to participate in consultations, however, he could not have his own patients there due to the lack of B2 or C1 level German language certificates.

After securing the opportunity for an educational visit to the Charité, our next big step was finding an apartment, which proved to be a major undertaking. There was already a significant housing shortage in Germany's capital under normal circumstances, and after two years of the COVID-19 pandemic and its corresponding lockdowns, the influx of tourists and seasonal workers was even greater.

Berlin's residents and political leadership were facing soaring rents, which have risen by up to 200% since 2006 (Perković, 2022), making finding affordable housing a very difficult task. The war that has been going on in Ukraine since February of 2022 has also contributed significantly to the occupation of housing throughout Germany. According to a BBC report, in the first four months of the war until July 2022, about one million Ukrainians have fled to Germany and were seeking refugee facilities and temporary housing (BBC, 2022). After months of searching for housing, we found a large semi-basement apartment in the Westend part of Berlin, just outside the ring road in the western part of the city, through a local German agency called Wunderflats.

We were very pleasantly surprised upon our arrival at Westend in Berlin. The neighbourhood was very quiet, the properties there were spacious and dominated by old villas with large gardens full of greenery. In addition, there were many embassies in Westend, which means that there was additional security, rendering the staying in that area even safer and more pleasant. Upon our arrival, we asked the landlords about public transportation in Berlin, which turned out to be one of the most efficient passenger transport systems we have ever used. We bought a monthly pass valid for all forms of Berlin public transportation (including bus, tram, overground, underground and commuter train) via the official BVG app (BVG, 2023). Fortunately, we found that Berlin's political leaders had reduced the price of the monthly public transportation pass from over €100 to just €9 per person for the summer of 2022 (June, July and August) in order to promote the public to use the public transportation instead of private cars, and thus helped to reduce harmful emissions.

As a result, over the course of the summer, roughly 52 million people bought the reduced public transport ticket to decrease CO₂ emissions by around 1.8 million tonnes (Feingold, 2022). On the first day of the observatorship in Berlin, we met professor Trampuž at the Charité Virchow clinic located in the Northern part of Berlin. We found security guards stationed at all entrances to the campus, requiring a negative COVID-19 test or a certificate of employment from each person entering the clinic. Thus, before entering, we had to show



the invitation to the clinic. Professor Trampuž then showed us around the clinic's campus and took us to the infection department, to which he is the head. We discussed the possibilities of observation and training in several different departments in regard to B.K.'s preferred specialty, that is orthopaedic surgery, and interests of E.K. and T.T.

3. Professional Education at Charité University Medical centre Berlin (E.K. and B.K.)

E.K. and B.K. have acknowledged during their stay, that in the Berlin's world of medicine, the Virchow-Klinikum Campus is considered the centre for emergency cases and septic surgery cases, especially musculoskeletal infections. On this campus, professor Trampuž runs his own research department regarding infections within the Musculoskeletal Surgery Clinic, and thus works closely with main surgeons. On the other hand, one of Charité's other campuses, Charité Mitte is considered to be the centre for primary surgery and revision surgery, and is home to some of the world's leading specialists in orthopaedic surgery. The Virchow-Klinikum and the Charité Mitte Campus have an intensive collaboration, with vans constantly running between them to transport health professionals for consultations and rounds. The other two Charité campuses, Benjamin Franklin and Berlin Buch, were not visited from a medical perspective but only from a tourist perspective, due to their geographical distance and limited collaboration of Professor Trampuž with colleagues from other campuses.

From a clinical perspective, B.K. found the work similar to the one experienced to that in Ljubljana: Patients obtain the appropriate referral from the doctor or specialist of their choice, who requires a consultation or an opinion from a specialist in Charité. Most physicians work in outpatient clinics at least once a week, but usually more often. What stands out in their work at the outpatient clinics is the excellent cooperation between experts from different specialties, which allows for a thorough and time-efficient approach to the patient care and treatment. It is therefore quite common for several different specialists to see and consult on a patient at the same time. Additional imaging diagnostics are also available within very short time limits.

Access to surgical or internal medicine services was primarily faster than B.K. has observed in Ljubljana but not many other major differences were envisaged. The drugs available were mostly the same or similar to those prescribed in Ljubljana, the treatment methods seemed similar, as did the protocols. Orthopaedic services and procedures seemed similar or the same as in Ljubljana. The use of newer instruments and devices stood out, but the methods of treatment and surgery seemed generally similar or the same as those administered in Ljubljana. B.K. and E.K. have observed that treatment of difficult pathology was concentrated in Charité, as the most challenging cases from all over Germany, sometimes even the world, were transferred there. Also, they had the opportunity to observe the treatment of a number of patients from Ukraine who had been injured in the current war.

Regarding the workload, the contractual work in Charité is generally 48 hours per week, but physicians are mostly present for longer than their regular work commitment. There is little time for additional, off-duty and after work activities. B.K. observed that annual leave is comparable, or slightly less than in Slovenia. Physicians' salaries are higher in Germany - about double the average physician's salary in Slovenia.

4. A University of Ljubljana Student Researcher's perspective (T.T.)

For the second author (T.T.), staying at the Charité Virchow-Klinikum was undeniably an unrivalled experience, which rooted her passion for scientific research and piqued her interest in renaissance-like thinking about contemporary medical issues.

During the first year of her Biology undergraduate studies at the Biotechnical faculty of the University of Ljubljana, T.T. decided that she wanted to spend her summer enhancing the knowledge and skills needed to become a successful researcher. She found professor Trampuž incredibly kind and fulfilled these desires, regardless of T.T. being at the beginning of her university journey. With immense gratitude, T.T. spent six weeks as an intern with his team. It was lovely to experience being a part of a very diverse group of interns, each of whom came from all over the world, including Turkey, France, Austria and Egypt.

The first part of the internship took place at the clinic, where B.K. was performing observation while E.K. and T.T. shadowed Professor Trampuž and his residents. Despite not being a medical student, a unique opportunity of T.T. to observe his approach to treating



the patients, hear the questions asked by physicians, following the discussions regarding optimal treatments - was invaluable because it demonstrated how research translates into treatments. As a Biology student, this opened the eyes of T.T. to the real-world problems healthcare is facing today in a very tangible manner. Consequently, it inspired her to ask herself wider research questions from a top to bottom perspective, seeking the big unanswered questions of physicians. T.T. believes that laboratory researchers, who do not have and insight into the experience of patients might not think of delving into these problems. The second part of the internship took place in the laboratories, where T.T. had the opportunity to observe the ongoing work of Ph.D researchers mentored by Professor Trampuž. These bright minds were likewise of international origin, working on research involving bacteriophages and antibiotics. T.T. was able to ask many questions, discuss and observe the methodologies applied, read and interpret the findings and analyses, as well as simply see what the life of a Ph.D. is like.

Wanting to demonstrate her capabilities, which had been enriched by the experiences from the past few weeks and the available literature, T.T. created a presentation about the novel cephalosporin antibiotic - Cefiderocol. This antibiotic had only been approved by the FDA in 2019 and is supposed to function as a Trojan horse, mimicking a structure inherent to bacteria to enter their cell wall without the fear of being rejected by bacterial resistance mechanisms (Fetroja, 2022). This structure is called a siderophore; it is secreted by bacteria to sequester iron from the environment and bring it back into their cytoplasm (Fetroja, 2022). Cefiderocol's molecular structure includes a siderophore-like component, which enables the antibiotic to penetrate the bacterium through a special iron-transport system (Fetroja, 2022). This renders the antibiotic immune to bacterial resistance mechanisms such as porin-channel changes, efflux pumps and different classes of beta-lactamases (Fetroja, 2022). Being able to override these three key resistance mechanisms (at least to a certain degree), makes this drug advertised as a game-changer in the fight against antibiotic-resistant Gram-negative bacterial strains (Fetroja, 2022).

Through the use of an array of scientific literature and discussions with colleagues, T.T. conducted a systematic review on the drug, including its biochemical and cellular mechanisms, *in vitro* and *in vivo* outcomes, as well as clinical trials and usage in Charité hospital itself. The conclusion was rooted in the argument that every merit of this antibiotic holds its value only to a certain extent, which opened up many more inquiries and possible improvements. The opportunity to discuss these findings with leading physicians and scientists in this field gave T.T. the confidence to question what else could be researched on the topic and from which angle to begin.

Charité allowed T.T. to think outside the box and be excited about all the knowledge that scientific research has yet to uncover.

5. Charité Universitätsmedizin Berlin

Charité is the largest university hospital in Europe and it is the oldest hospital in Berlin. The hospital was founded over 300 years ago, in 1710, just north of the wall that surrounded Berlin at the time. Frederick I of Prussia had the hospital built in order to provide quarantine facilities to isolate patients suffering from bubonic plague (World Health Summit, 2022). As the plague outbreak across Europe drew to a close, the building was used as a hospice for the elderly, homeless and poor, and as a shelter for unwed mothers. After 17 years, the King Frederick I of Prussia had the building renovated, adding additional floors and rooms, and expanding the building's purpose; in addition to being a shelter for the poor, it also became a hospital for the care of those injured in the war. Since then, it has also served as a place for the training of future war doctors. At that time, the hospital was renamed Charité (Charité, History of Campus Charité Mitte, 2022), that is French for charity (Pons, 2023), as it is known today.

Today's Charité University Clinic consists of 4 campuses; the Charité Mitte Campus, the Virchow-Klinikum Campus, the Benjamin Franklin Campus and the Berlin Buch Campus.

5.1 Campus Charité Mitte

The Charité Mitte Campus is located in the central Mitte area of Berlin. The campus is considered as an original part of the Charité hospital complex, consisting of buildings that were built as early as the time of King Frederick I and were only renovated or newly built at the turn of the 19th and 20th centuries. This was also the time of building of the famous red brick building (**Figure 1**), which is today one of the most recognisable parts of Charité (Charité, History of Campus Charité Mitte, 2022).

During the World War II, much of the Charité Mitte campus was destroyed by shelling and bombing. During the subsequent Cold War and the division of Germany into the east and west sectors, the campus belonged to the eastern part of Berlin and thus to the German Democratic Republic, which extensively renovated the hospital and added new, specialised facilities meant to promote the government's policy. Nowadays, the 22-storey tower block, around which several smaller buildings or structures are located, stands out as a particular Berlin landmark (Charité, History of Campus Charité Mitte, 2022).



Figure 1: Red brick building of Charite Mitte (Dreamstime, 2022).

4.2 Campus Virchow-Klinikum

The Virchow-Klinikum campus was built at the beginning of the 20th century on the initiative of Rudolf Virchow, one of the most prominent physicians and pathologists of the 19th century. His most famous work includes cell theory and the origins of disease. Virchow explained that disease does not begin spontaneously in organs or tissues in the body, but in individual cells, from which it then progresses through tissues and organs (Underwood and Ashworth, 2022). The Virchow-Klinikum campus consists of a main green avenue, which is almost 500 metres long, and divides the campus in two sides of hospital buildings (**Figure 2**).



Figure 2: The Virchow-Klinikum campus (Belin Health Excellence, Campus Virchow-Klinikum, 2022).

As foreseen in the original design of the campus, the left side of the avenue mainly hospitalises surgical patients, while the right side is used for patients with non-surgical or internal problems. The Virchow-Klinikum Campus was rebuilt after the World War II (Charité, History of Campus Virchow-Klinikum (CVK), 2022). The many benches, the boardwalk and the fountain at the end of the avenue make the campus feel very open and welcoming for both patients and medical staff. Unlike the Charité Mitte Campus, the Virchow-Klinikum Campus belonged to West Berlin during the Cold War, and only joined the Charité University Clinic complex at the end of the 20th century (Charité, History of Campus Virchow-Klinikum (CVK), 2022).

4.3 *Campus Benjamin Franklin*

The Benjamin Franklin Campus was built in the second half of the 20th century during the Cold War, when the western sector of Berlin was left without a university. A new one was thus founded in 1948, followed by the construction of a new university hospital in the South of the city. About one-fifth of the hospital's construction costs were covered by the US, which led to the campus being named after the famous United States presidents, Benjamin Franklin. The campus is built as a large building with several wings and a large park in front of it where patients and medical staff can take walks and get a taste of nature (**Figure 3**). The Benjamin Franklin Campus joined the Charité University Clinic complex at the beginning of the 21st century (Charité, History of the Campus Benjamin Franklin, 2022).



Figure 3: Campus Benjamin Franklin (Berlin Health Excellence, Campus Benjamin Franklin, 2022).

4.4 Campus Berlin Buch

The last of Charité's four campuses, Berlin Buch is located in the North-Eastern part of Berlin. For more than 100 years, it has played a leading role in German medical, clinical and laboratory research. Biomedicine is very important in the research work conducted at Berlin Buch, but interdisciplinary collaboration is also crucial and is further facilitated by the physical proximity of the buildings on the campus (**Figure 4**). The campus also includes the BiotechPark Berlin-Buch, the largest biotechnology park in Germany with offers space for laboratories and research facilities (Campus Berlin-Buch GmbH, 2022).



Figure 4: Campus Berlin Buch (Helios, 2022).

5. Conclusion

The visit at Charité Universitätsmedizin Berlin was interesting, but organisationally challenging. The professional environment there was very stimulating, with all the latest technologies and knowledge available to use, and the ease and speed of the interdisciplinary approach and treatment was gratifying. Treatment of the patients seemed advanced, developing as an evolution and not a revolution. For a student or researcher, a visit to Charité



and Berlin was an opportunity to broaden horizons for the future work, both in terms of research and potentials of modern laboratories, as well as in terms of the transfer of this experience and knowledge into everyday (clinical) practice.

References

1. BBC (2022), How many Ukrainian refugees are there and where have they gone? Accessed January 2023. Available from <https://www.bbc.com/news/world-60555472>.
2. Berlin Health Excellence (2022), Charité – Campus Benjamin Franklin. Accessed January 2023. Available from <https://www.berlin-health-excellence.com/medical-facilities-berlin/charite-campus-benjamin-franklin>.
3. Berlin Health Excellence (2022), Charité – Campus Virchow-Klinikum. Accessed January 2023. Available from <https://www.berlin-health-excellence.com/medical-facilities-berlin/charite-campus-virchow-klinikum>.
4. BVG (2022). Accessed January 2023. Available from <https://www.bvg.de/en>.
5. Campus Berlin-Buch GmbH, (2022) Location of future innovation. Accessed January 2023. Available from <https://www.campusberlinbuch.de/en/Index>.
6. Charité (2022), Charité Campus Berlin Buch. Accessed January 2023. Available from https://www.charite.de/en/charite/campuses/campus_berlin_buch/.
7. Charité (2022), Eighth and final statement by Charité – Universitätsmedizin Berlin: Details of Alexei Navalny's treatment published in scientific journal. Accessed January 2023. Available from https://www.charite.de/en/service/press_reports/artikel/detail/eighth_and_final_statement_by_charite_universitaetsmedizin_berlin_details_of_alexei Navalny_trea/.
8. Charité (2022), History of Campus Charité Mitte. Accessed January 2023. Available from https://www.charite.de/en/charite/campuses/campus_charite_mitte/history_of_campus_charite_mitte/#c30016994.
9. Charité (2022), History of Campus Virchow-Klinikum (CVK). Accessed January 2023. Available from https://www.charite.de/en/charite/campuses/campus_virchow_klinikum/history_of_campus_virchow_klinikum/#c30016989.
10. Charité (2022), History of the Campus Benjamin Franklin. Accessed January 2023. Available from https://www.charite.de/en/charite/campuses/campus_benjamin_franklin_cbf/location_map_map_key_cbf/.
11. Dreamstime (2022), Hospital Charité Berlin, Germany. Accessed January 2023. Available from <https://www.dreamstime.com/editorial-photo-hospital-charite-berlin-germany-historical-part-building-image75249731>.
12. Feingold, S. (2022), Germany's €9 transit ticket cuts 1.8 million tonnes of CO2. Accessed January 2023. Available from <https://www.weforum.org/agenda/2022/08/germanys-9-euro-transport-ticket-cut-1-8-million-tons-of-co2/>.
13. Fetroja (2022), Fetroja® (cefiderocol). Citirano 10.8.2022. Accessed January 2023. Available from <https://www.fetroja.com>
14. Helios (2022), Erstklassige Medizin, Fürsorge und Kompetenz. Accessed January 2023. Available from <https://www.helios-gesundheit.de/kliniken/berlin-buch/unser-haus/klinik-im-portait/>.
15. Perković J. The fight for stable homes during Berlin's rental crisis. 2022; Available from <https://assemblepapers.com.au/2022/03/08/behind-the-great-housing-crisis-of-berlin/>.
16. Pons. Accessed January 2023. Available from <https://en.pons.com/translate/french-slovenian/charite>.
18. Underwood, E. Ashworth (2022), Rudolf Virchow. Encyclopedia Britannica. Accessed January 2023. Available from <https://www.britannica.com/biography/Rudolf-Virchow>.
19. World Health Summit (2022), M8 Alliance members. Accessed January 2023. Available from <https://www.worldhealthsummit.org/m8-alliance/members/charite.html>.

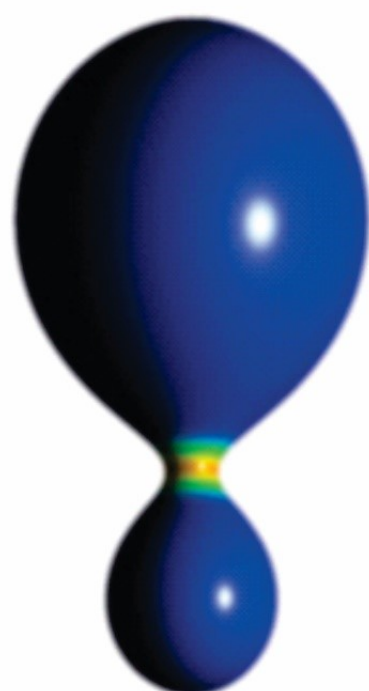
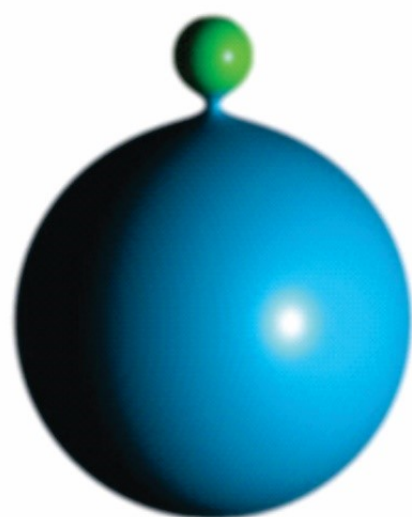
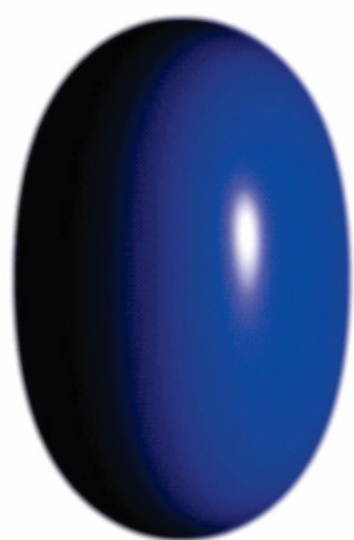



Reflection

"Beethoven in Heiligenstadt in the Museum dedicated to him: the Man and the Artist"

Schmid Roberta ^{1,*}, Lamberti Giancarlo ¹

* Correspondence: robischmid@libero.it

Citation: Schmid R, Lamberti G. Beethoven in Heiligenstadt in the Museum dedicated to him: the Man and the Artist. Proceedings of Socratic Lectures. 2023, 8; 187- 191.
<https://doi.org/10.55295/PSL.2023.II23>

Publisher's Note: UL ZF stays neutral with regard to jurisdictional claims in published maps and institutional affiliations.



Copyright: © 2023 by the authors. Submitted for possible open access publication under the terms and conditions of the Creative Commons Attribution (CC BY) license (<https://creativecommons.org/licenses/by/4.0/>).

Abstract: The purpose of this contribution is to reflect on the human and musical figure of the great composer Ludwig van Beethoven. In 1802, Beethoven visited Heiligenstadt and in October 6 he there wrote his famous "Testament" that was found after his death in 1827. The authors have visited the Museum dedicated to Beethoven in Heiligenstadt in the summer of 2022.

Keywords: Beethoven; Music; Testament; Heiligenstadt

1. Beethoven in Heilingenstadt

The name Heilingenstadt means "holy city" suggesting that this was a place of religious worship already in pre-Christian times. In medieval times, the area was rich, the inhabitants lived from agriculture, fishing on the western branch of the Danube and from the production of wine: the nearby and important Klosterneuburg Monastery already owned large vineyards around 1250. Economic crisis occurred after the "second siege of Vienna" in 1683. During this great clash with the Ottoman army, many of local inhabitants were massacred. The economy gradually recovered during the 18th century as local livestock and fruit became popular in Vienna's markets. The recovery was also favored towards the end of the 1700s by the construction of a SPA, which exploited a hot water spring. Up to 300 people frequented the place and the adjacent restaurant every day. In the summer months, Heilingenstadt became a popular tourist destination (Figure 1).



Figure 1. A postcard showing the tourist nature of Heilingenstadt.

Dr. Johann Adam Schmidt - professor of Anatomy in Vienna - to whom Beethoven had turned because already afflicted by pressing deafness problems, had suggested a period of rest in a quiet place and in contact with nature. To his advice, Beethoven rented a rustic house in Heilingenstadt, Probusgasse and spent whole days in solitude, eating his meals in a nearby tavern. This was the place where the great composer had lived from April to October 1802 and where in a moment of great despair, wrote heartfelt pages addressed to his two brothers: the text was never sent and was found among his papers only after his death; it went down in history as "Testament of Heilingenstadt" and is preserved and exhibited in the Museum.

2. Reflections on the Museum

The exhibit takes visitors through 14 rooms.

Beethoven's memory is preserved here also through many handwritten notes, notebooks, conversation books, letters and everyday objects, that testify the musician's working routine, private life and state of health, as well as the genesis, meaning and impact of some of his compositions on the public.

The room dedicated to *Fidelio*, the only opera written by Beethoven, is very interesting: the plot and the different political interpretations that characterized the subsequent performances are very well explained.

The room where Beethoven's piano is shown is touching because the composer, in order to amplify the sound, had placed the metal scaffolding, normally superimposed on the prompter's box on the stage, on it (**Figure 2**).



Figure 2. Beethoven's piano with sound amplifier. Photo: G. Lamberti.

We know that, as early as 1804, Beethoven's compositions frequently appeared in concert programs as those of Haydn and Mozart, and they were all printed during his lifetime, often under his direct supervision. Count Waldstein, to whom Beethoven later dedicated the Piano Sonata op. 53, and who had already been his main patron in Bonn, with his contacts facilitated his introduction into the palaces of aristocrats, where the young musician was immediately appreciated as piano virtuoso and improviser.

Among the patrons who supported Beethoven, worthy of mention are Prince Lobkowitz, the Russian Count Razumovsky and mainly Prince Lichnowsky, who from 1800 to 1806 even granted him an annual fixed allowance. Thus at the age of 30 Beethoven could already sell his compositions to various publishers - even foreign ones - or to music lovers and aristocrats, who in exchange required a dedication and the exclusive right to perform them for a certain time.

Although the upper classes commissioned, played and appreciated his music, at the same time they demarcated some strict social boundaries that he could not cross: this was also due to the political climate of restoration and new social order sanctioned in the Congress of Vienna (1815). Beethoven never showed open sympathy for the French Revolution, but he always remained faithful to the ideals of freedom, brotherhood and respect for human rights.

Beethoven's initial intention to name his Third Symphony "Bonaparte" is well described within the Museum, but then, disappointed when Napoleon proclaimed himself "emperor", he wrote on the score: "Sinfonia Eroica, composed to celebrate the arrival of a great man".

Even musically, Beethoven got elements from the French revolutionary music: most likely the theme of the last movement of the Fifth Symphony was taken from Gossec's Revolutionary Hymn "To the Dead of the Gironde", of emphatic simplicity.



The Third Symphony itself was influenced by the monumental nature of French music at the end of the 18th century, as was the entire second period of Beethoven's production (1803-1815), defined by critics as a "heroic style": it is characterized by an emphatic drive towards the grandiose, as well as by the enhancement of simple and elementary motifs (think of the incipit of the 5th Symphony), therefore susceptible to much more elaborate and complex developments.

His music was not designed to be easily accessible, especially during the so-called "third manner". The late Beethoven is the initiator of the artistic avant-garde in the history of music. His last compositions are even devoid of the prospect of an immediate performance: "This music is not for you, but for posterity" Beethoven himself would have stated in response to Muzio Clementi's perplexities regarding the opera 59.

From the analysis of his musical sketches it was understood that Beethoven's process in composing was very different from that of Mozart, whose first inspiration had undergone the character of completeness. His creative path was instead slow and gradual and he usually made numerous attempts and trials before getting to the definitive formulation of a theme (it took him almost 10 years to complete the 9th Symphony, whereas Mozart had composed his last 3 symphonies in less than 2 months).

3. Heilingenstadt Testament

However, the most moving element inside the Museum, like a sacred relic, is undoubtedly the so-called "Heilingenstadt Testament" (**Figure 3**).

"O men who consider me and call me a spiteful, stubborn and misanthropic being, how unjust you are to me! You ignore the secret reason that makes me appear this way to you... just think that for six years I have been struck by an incurable disease..."

The drama of his hearing loss will lead Beethoven to progressive isolation from social life ("...I soon had to isolate myself and spend my life in solitude...").

But, above all, admitting the deafness could deprive him of his credibility as a musician before the world ("...Ah, how can I confess the weakness of a sense that I should possess more perfect than any other... it was not possible for me to ask: "Speak louder, shout, because I'm deaf...so forgive me if you see me withdrawn, when instead I would gladly join you" ...).

Beethoven was a person of profound culture and not being able to relate to the world was a great intellectual impoverishment for him. And then he tells about his desperation: "As soon as I get close to people I am seized by a terrible anguish of being exposed to the risk of making my state known I was close to putting an end to my days myself..."

But then he immediately adds "the Art, it alone held me back..."

Music then becomes the only salvation, a revealing instrument of the highest values between man and the beyond.

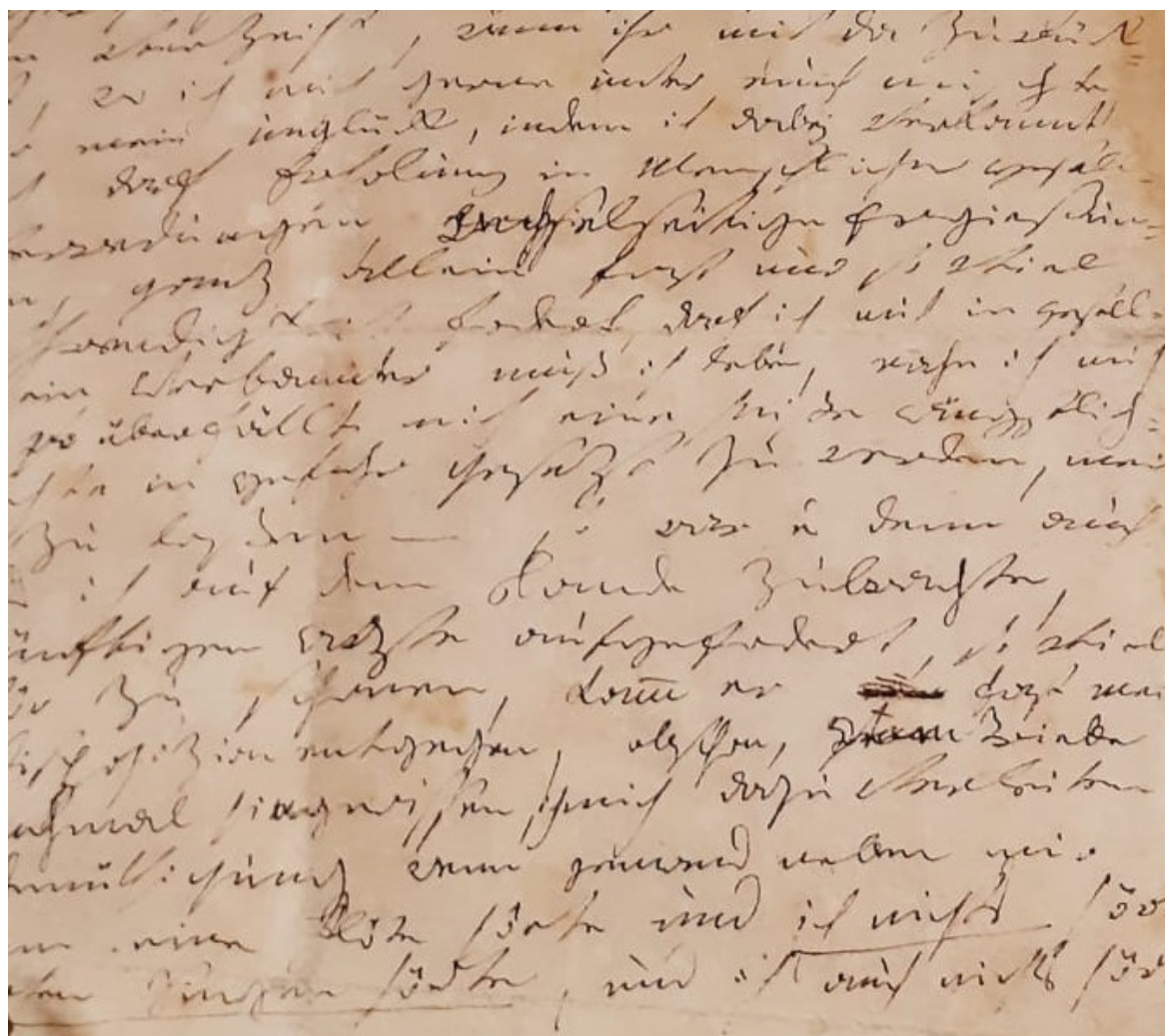

Figure 3. A segment of the reproduction of the testament. Photo: G. Lamberti.

Beethoven is perhaps the first musician in history who considers himself invested with a mission, that of transmitting a universal message destined to last over time.

Beethoven would fulfil his "duty" as a musician to the end: starting from the "Pastoral" Symphony up to the grandiose Symphony No.9, with which - inserting a choir for the first time in the history of Music - he arrives at the luminous and conclusive joy of a such a painful journey.

Beethoven is not only one of the greatest musicians of all time, but he leaves us with a great ethical inspiration.

Faced with a handicap and the desperation and shame that arose from it, Beethoven chose life and decided to continue composing despite his insurmountable limit. Beethoven chose to live with his deafness, to overcome it and go further, leaving us with a unique testimony of superhuman strength, desire, courage and will.

In our opinion, if Beethoven's contemporaneity emerges from his profound faith in reason and freedom, his universality is measured in "having known how to leverage pain and anger, through a titanic effort, not to destroy, but to create".

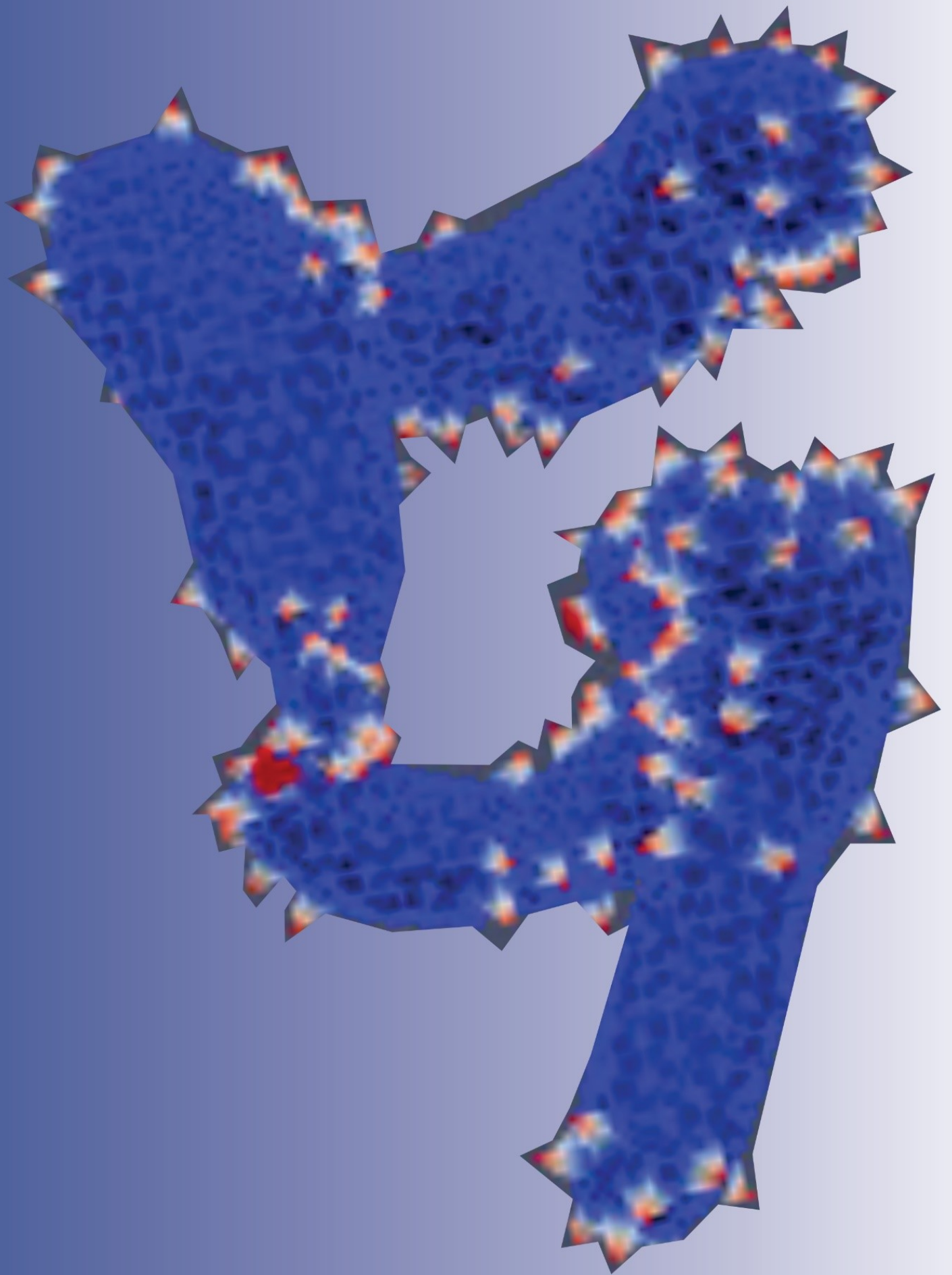



Reflection

Students' Reflections on 8th Socratic Lectures

Štrbac Aleksandra¹, Ambrožič Janja¹, Barlič Leja¹, Berce Nika¹, Bolte Nuša¹, Čoralić Ajla², Cingere Matija¹, Černigoj Aljaž¹, Dedić Amra¹, Djura Meta¹, Fuks Tia¹, Georgijev Blaž¹, Gosarič Urban², Gril Mirjam¹, Jakše Maruška¹, Japelj Neža¹, Jesenko Petra¹, Keber Pia¹, Klančnik Klara¹, Kne Uma¹, Kozjek Zala¹, Krk Loti¹, Kuselj Klara¹, Lalović Zoja¹, Lazić Leon¹, Lesjak Sara¹, Lešnik Jon¹, Majcen Sandra¹, Malič Sara¹, Marenče Manca¹, Maselj Petja¹, Mesić Alen¹, Mihelič Ajda¹, Miholič Anja¹, Miljkovic Emina², Modrijan Kim¹, Moškrič Lara¹, Oprin Anamarija¹, Ozmec Maja¹, Pikec Tinkara¹, Požgaj Svitl¹, Prelec Tijana¹, Primožič Sara¹, Pristov Alja¹, Puškar Raisa¹, Sok Nika¹, Sovič Maruša¹, Škof Anej¹, Šuštarich Valentina¹, Topolovec Nika¹, Udovč Šink Živa¹, Vaš Taris¹, Zupančič Urša¹, Kralj-Iglič Veronika^{1,*}

Citation: Štrbac A, Ambrožič J, Barlič L, et al., Students' reflections on 8th Socratic Lectures. Proceedings of Socratic Lectures. 2023, 8; 193-196.
<https://doi.org/10.55295/PSL.2023.II24>

- ¹ University of Ljubljana, Faculty of Health Sciences, Ljubljana, Slovenia
² University of Ljubljana, Faculty of Medicine, Ljubljana, Slovenia
 * Correspondence: Veronika Kralj-Iglič; veronika.kralj-iglic@zf.uni-lj.si

Publisher's Note: UL ZF stays neutral with regard to jurisdictional claims in published maps and institutional affiliations.



Copyright: © 2023 by the authors. Submitted for possible open access publication under the terms and conditions of the Creative Commons Attribution (CC BY) license (<https://creativecommons.org/licenses/by/4.0/>).

Abstract: Symposium Socratic Lectures is primarily devoted to the students. For 15 years, excellent scientists donate their lectures to the students who are the *agens movens*, for their dedication and interest. The students were actively involved in discussions. Recently developed technologies enabled creation of documents by simultaneous writing in real time during the symposium. In this contribution, the reflections of the students on the content of symposium are given in terms of statements.

Keywords: Education; Open book; Social networks



1. Curriculum

Socratic Lectures that took place on Saturday, January 21 online, from 10 a.m. to 2 p.m. were the final event of the 1.st semester study in academic year 2022/2023. Included were the students of the subject Biophysics and Biomechanics (1.st year of Orthotics and Prosthetics and 1.st year of Laboratory Dental Prosthetics, Faculty of Health Sciences), the subject Biomechanics of joints (2.nd – 6.th year of General Medicine, Faculty of Medicine) and the subjects Biophysics of membranes, Biomechanics and Biophysics and Electrostatics of surfaces (Doctoral School of the University of Ljubljana). For the undergraduate students, the symposium offered the possibility to gather sufficient bonus to be excused of the written exam. A day before (on January 20, 2023), the students of the Faculty of Health Sciences were gathered for solving physical problems within the open-book system. At the symposium, the students listened to the plenary lecture and then they were uniformly divided over the scientific sections. There were 7 sections (Human Medicine, Veterinary Medicine, Musculo - Skeletal Health, Prosthetics, Physics, Nanostructure and Crossroads of Science, Medicine, Art and Education). The role of the students was to record the impressions in the form of reflections. GoogleDrive tools were used to design the documents on each section and all participants of the symposium were given the access to the link. The idea was to benefit from the gathering of many excellent scientists to concentrate the knowledge on particular subjects. Below, the selected reflections are presented in the form of statements.

1.1. Plenary lecture (Sergej Tomić)

Small cellular particles are tiny materials having size ranges from 1 to 100 nanometers. They can have different shapes and are classified according to their properties. They have great potential in medicine and pharmaceuticals because of their specific mechanical, optical and electrical properties.

1.2. Human medicine (Chaired by Boštjan Kocjančič and Yelena Istileulova)

Gold nanoparticles are attractive and broadly used nanomaterials in the biomedical areas for analytical purposes such as medical diagnosis labeling and biosensing. They are being applied to capture cancer-associated proteins, circulating tumor DNA, circulating tumor cells, and exosomes. Nanotechnology enables the manipulation of materials at nanoscale and has shown potential to enhance sensitivity and selectivity and lower the cost of diagnostics.

1.3. Musculo-skeletal health (Chaired by Renata Vauhnik)

The musculo-skeletal system is an essential component of human health. The emerging problems in musculo-skeletal health are osteoporosis, arthritis, bone and joint problems, cancer and bone fractures. Osteoporosis is the weakening of bones that occurs when the body loses bone tissue that is not adequately replaced. As people age, they are more likely to develop osteoporosis and be at higher risk of broken bones. Osteoarthritis results from the deterioration of the cartilage that coats and cushions bones, enabling joints to operate smoothly. Loss of cartilage results in pain, swelling and movement problems. Rheumatoid arthritis is caused by inflammation of the joints and other tissues. Often, it is caused by autoimmune disorders. Bone and joint problems can develop in association with other conditions, such as diabetes, chronic kidney disease, or genetic disorders.

Several types of cancer can originate in bone tissue. Multiple myeloma cause abnormalities in the bone marrow and other bone tissues.

Musculoskeletal biomechanics aims to understand the effects of age, activity, disease and various causes of pain, including acute, chronic and recurrent conditions. A broad range of methods and experimental conditions are used to study movement strategies and function.

Biomechanical parameters provide crucial information differentiating pathological gait and posture and can be used to assess the risk of falling in elderly. Pattern recognition models based on biomechanical parameters may provide greater insight for such classification. The biomechanical multiphysics model is a powerful tool for analyzing the mechanical functions of living systems. The biomechanical parameters extracted from the



force plate data include the three-dimensional Ground Reaction Force (GRF) data and can be recorded in a stance or in gait. GRF data are normalized to body weight and percent stance duration.

1.4. *Veterinary medicine (Chaired by Vladimira Erjavec and Angelo Beletić)*

Liposomes have been considered promising and versatile drug vesicles. In comparison to traditional drug delivery systems, they exhibit better properties, which include protection of drugs from degradation and clearance, superior therapeutic side effects, lower toxic side effects, side targeting, sustained or controlled release. Several liposomal drug products have been approved and are used in clinics. Single cell proteins or microbial proteins refer to edible unicellular microorganisms.

Biomaterial implants are an established part of medical practice, encompassing a broad range of devices that widely differ in function and structural composition. However, one common property amongst biomaterials is the induction of the foreign body response: an acute sterile inflammatory reaction which overlaps with tissue vascularisation and remodelling and ultimately leads to fibrotic encapsulation of the biomaterial to prevent further interaction with the host tissue. Severity and clinical manifestations of the biomaterial-induced foreign body response are different for each biomaterial.

1.5. *Prosthetics (Chaired by Blaž Mavčič and Drago Dolinar)*

Prosthetic devices are becoming more and more common in both the medical and engineering fields, and now many body parts can be replaced by a prosthesis. Prosthetics is a part of the bio-mechatronics which is the science of using mechanical devices with human muscles, skeleton, and nervous system, to assist or enhance motor control lost by trauma, disease, or defect. These devices can help the individual accomplish the tasks that they previously could not. This significantly improves the quality of life. There are many materials in prosthetics such as metals, polymers, carbon fibers etc. Prostheses vary in size, weight, lifestyle, and design required by the type of amputation. Thus there is not one material or design that will fit all needs.

1.6. *Physics (Chaired by Aleš Iglič and Matej Daniel)*

Small cellular particles (SCPs) are sub-micron particles harvested from different samples, which contain cells (like for example body fluids). Methods for SCPs characterization are dynamic light scattering, flow cytometry, nanoparticle tracking analysis and other methods. The term batch methods means methods that include a large number of particles. The most important parameters are the number density and the size of the particles in the samples. With different microscopic techniques, the morphology of different particles in the samples can be determined. An essential element of a biomembrane is a lipid bilayer, which is composed of lipid molecules. These molecules have a hydrophilic head and a hydrophobic tail.

Nanomaterials are applied for the detection of biological molecules, imaging of diseased tissues and innovative therapeutics. Nanoparticles can be used for drug delivery. Liposomes and SCPs can be used for targeted drug delivery, as they can be functionalized to target specific cells or tissues in the body. Inorganic nanoparticles, on the other hand, are not composed of natural materials, but of metals, ceramics, or semiconductors. They are typically smaller than SCPs and liposomes and have unique optical, electronic and magnetic properties, which can be exploited for various applications.

1.7. *Nanostructure (Chaired by Gabriella Pocsfalvi and Gitta Schloser)*

A nanostructure is a structure of intermediate size between microscopic and molecular structures. Nanostructural detail is microstructure at nanoscale. Nanoscale structure in biology is often called ultrastructure. Mass spectrometry is one of the fastest and most powerful analytical tools of all time. Atoms are ionized and analyzed. They are moving within a mass analyzer. Mass spectrometry is used to identify, quantify and analyse the role of molecules in diseases and different processes. Proteomic analysis showed that there are more than 3000 proteins in the isolated extracellular vesicles (EVs) of healthy individuals. Urine EVs have a potential to be used in diagnostics of different diseases,



including those involving distant organs like lungs and breast, as they move within all body fluids. Proteins on EVs can be labelled and subsequently followed through the organism. Thereby certain processes can be elucidated on a very small scale which wouldn't be possible otherwise. The end result shows up and down-regulated proteins. These are proteins that are either too common or too scarce in the organism, respectively. A specific subset of 1300 proteins were identified as a human membranome. Plasma derived EVs could have an effect in immunological processes. Hence they play a role in viral infections, e.g. in COVID-19. Gene expression can vary in time and due to different condition. Liquid Chromatography – Mass Spectrometry is the most widely used method for identification of proteins. Proteins cannot be sequenced easily while peptides can. Specific enzymes (e.g. trypsin, Lys-C) can assist in sequencing peptides. Carbohydrates can be attached to polypeptides to form glycoproteins. Prions are small parts of proteins that are used for analysis of hydrophobic interaction. A correct structure of the protein, including its tertiary and quaternary structure is necessary for its normal functioning. Protein misfolding in small proteins derive from breaking the hydrogen bonds which may induce a change in the protein structure. Hydrogen bonds in beta structure are slightly weaker than in alpha structure so the chain may misfold. Thermodynamics is an important factor in folding of protein chains.

1.8. Crossroads of Science, Medicine, Art and Education (chaired by Anita Prelovšek and Tatia Dolidze)

The main challenge is to prevent law students from learning legal texts by heart because critical thinking and analytical thinking are important in this profession. Open book method is therefore preferred. Within this method, the student is allowed to use all kinds of sources (e.g. literature) in order to develop analytical and critical thinking. An important point is selecting appropriate teaching methods that allows programs to include a large number of courses. Each of these courses has its specifics, so the key point is to select appropriate methods for each locus. The times are changing and so are the methods in education. Medical education itself is constantly developing and there are several new methods of teaching. The COVID pandemic induced implementation of technologies in education. Due to priorities to treat patients, the students had less access to clinical experience and alternative methods were developed. Two new methodologies were introduced: The first is the virtual anatomy class where students could use computer programs to envisage the organ systems. High quality images are a valuable tool and help in memorization. The second is the virtual patient simulator. This tool represents the clinical cases with different scenarios. The student considers a case beginning with questioning the simulated patient. The problem must be solved in a limited time.

Ludwig van Beethoven is one of the best classical composers to ever walk the earth. Despite gradually losing his hearing this medical condition did not prevent him to write music. Some of his best work was written in complete absence of hearing. His legacy will forever be remembered and cherished all over the globe.

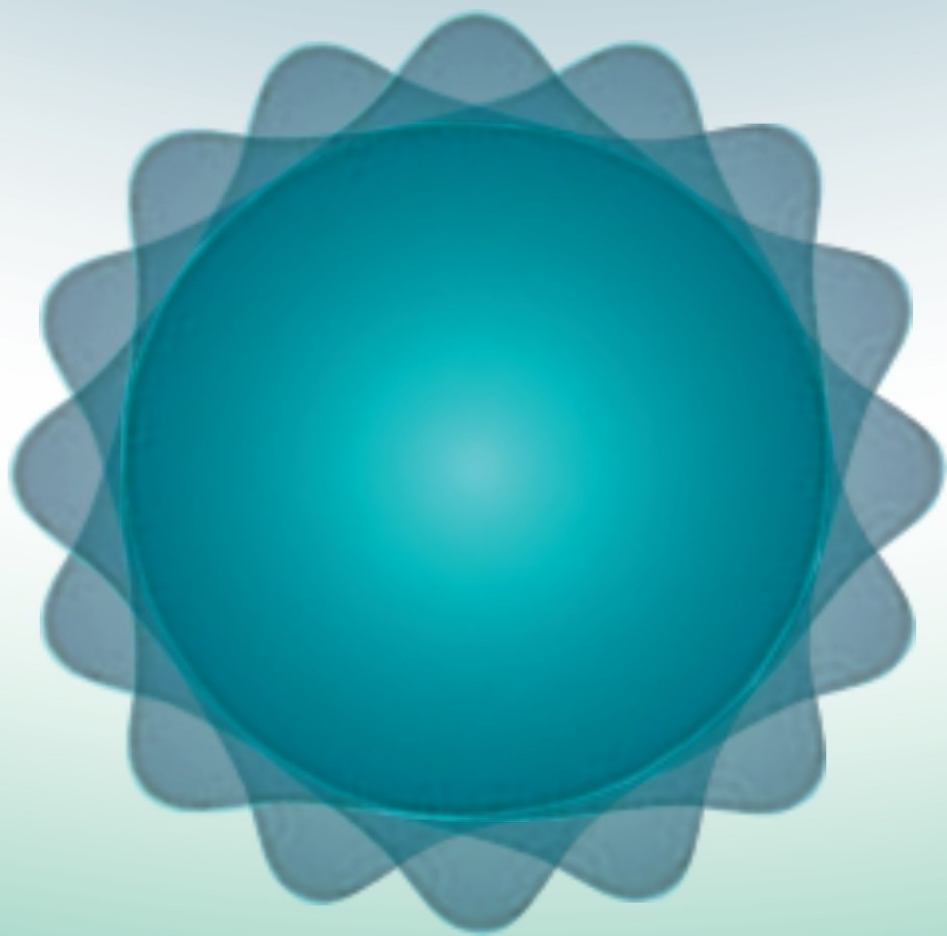



Invited lecture/Scientific contribution

Observation on Tuberculosis Preventive Treatment in Georgia

Kokhreidze Eka^{1,2}, Avaliani Zaza^{1,2}, Gabashvili Nino^{1,2}, Zamutashvili Maia^{1,3}

1. European University, Tbilisi, Georgia
2. National Center for Tuberculosis and Lung Disease, Tbilisi, Georgia
3. Infectious Diseases, AIDS and Clinical Immunology Research Center, Tbilisi, Georgia
- * Correspondence: EkaKokhreidze; eka.kokhreidze@eu.edu.ge

Abstract:

The uptake of latent tuberculosis infection treatment (LTBI) is an important measure to prevent active tuberculosis (TB), but has not been well studied in low and middle-income countries (LMICs). The lifetime risk of developing active TB for people with LTBI is 10-15%. Within the national guidelines of National Tuberculosis control Program (NTP) 2020 in Georgia, 6 months isoniazid preventive treatment (IPT) was replaced with 3 months rifampentine treatment. Here we present the results of the care cascade of LTBI treatment of subjects to whom the Tuberculosis Preventive Treatment (TPT) in Georgia was recommended. We performed a cohort-study during 2020-2021 in which we applied a mixed method recommended for TPT. We assessed active pulmonary TB cases to whom IPT was recommended and in cases not completing a tuberculosis preventive treatment, the respective reasons. Among 678-contacted subjects, 54% were female and 46% were male. There was no age limit. Overall 164 participants initiated TPT, among them 107 completed the treatment. 72% from all participants were in close contact with TB-patients/ index cases and were living in the same household. 49% of index cases were positive to culture test (culture test involves studying bacteria by growing the bacteria on different substances) and 45% were Drug Sensitive Tuberculosis (DST) positive. 23 cases of index cases were MultiDrug-Resistant (MDR) TB patients. 95 (14%) participants were treated at the National Center for Tuberculosis and Lung Diseases, other participants were treated at other regions of Georgia (Kakheti, Kutaisi, Rustavi, Gori). From 22 children under 5 years of age who were recommended for the Tuberculosis Skin Test (TST), 2 were positive. Our findings highlight very low rates of LTBI treatment recommendation, initiation and completion in Georgia and hence the need for improved monitoring and treatment programs.

Keywords: Communicable disease, Infectious disease, Tuberculosis, Latent tuberculosis, Prevention, Epidemiology.

Citation: Kokhreidze E, Avaliani Z, Gabashvili N, Zamutashvili M. Observation on Tuberculosis Preventive Treatment in Georgia. Proceedings of Socratic Lectures. 2023, 8; 198-202. <https://doi.org/10.55295/PSL.2023.II25>

Publisher's Note: UL ZF stays neutral with regard to jurisdictional claims in published maps and institutional affiliations.



Copyright: © 2022 by the authors. Submitted for possible open access publication under the terms and conditions of the Creative Commons Attribution (CC BY) license

**Abbreviations:**

TB-Tuberculosis

LTBI-Latent Tuberculosis Treatment

MDR-TB- Multy drug resitance tuberculosis

DS-TB-Drug Ssensitive Tuberculosis

IPT-Isonizid Preventive Treatment

TPT-Tuberculosis Preventive Treatment

Lfx-Levofloxacin

TST-Tuberculine Skin Test

NCTLD-National Center for Tuberculosis and Lung Disease

1. Introduction

A key component of the END TB Strategy is to prevent new TB cases through TB preventive treatment (TPT). Implementing this intervention is critical given that the World Health Organization (WHO) estimates that a quarter of the global population has LTBI thus serving as a large reservoir for incident TB cases. Historically, due to limited resources and inadequate tools, highly burdened countries have focused on diagnosing and treating active TB cases with a lower priority placed on LTBI. The momentum to combat LTBI has increased in recent years partly driven by commitments provided at the 2018 UN High Level Meeting on TB to provide TPT to 30 million people by 2022. However, WHO data indicated that only ~500,000 household contacts of active TB were treated in 2019 and highlighted that the track to meet targets are way off. ("Global Tuberculosis Report 2020" n.d.)

Since 2015, the country of Georgia no longer belongs to the highly burdened countries, however the number of drug-resistant TB cases remains a major problem. According to the WHO, the number of TB cases in Georgia detected in 2021 was 2400, among them 410 were MultiDrug-Resistant TB (MDR) cases and only 13% from all TB cases that were in contact with infected subjects initiated TB preventive treatment (TPT). ("WHO Operational Handbook on Tuberculosis: Module 1: Prevention: Tuberculosis Preventive Treatment" n.d.; "Global Tuberculosis Report 2022" n.d.)

Georgia follows WHO's recommendations and updates national TB strategy based on the newest recommendation. Till 2020, TPT was recommended only for two prioritized groups of people, HIV positive patients and children aged 0-5, who were close contacts of bacteriologically confirmed drug sensitive TB cases (DS-TB). TPT regimen was 6-month isoniazid treatment (6INH). Results of a previous study showed a very low rate of TPT initiation and completion. In addition, 4 children among 135 who were recommended for TPT developed an active TB in one year of period. All children were from the group which did not initiate the preventive treatment ("LTBI Preventive Treatment in Children in Country of Georgia," n.d.).

After March 2020 the strategy of TPT was updated based on WHO's guidance, which means that all persons who were in close contact with active TB cases in any age are recommended to start TPT: not only the persons that were in close contact with DS-TB patients, but also MDR-TB cases. In addition, the treatment regimen 6INH was replaced with 3PH (3-month rifapentine) for DS contacts and 6lfx (6-month levofloxacin) - for MDR contacts. Beside this, targets of recommendations were widened. Risk groups such as - (1) HIV positive people, who are initiating anti-TNF treatment; (2) receiving dialysis, (3) preparing for an organ or (4) hematological transplant, (5) who have silicosis should be systematically tested and treated for LTBI (Gabunia 2019). After the changes of the recommendations, we have evaluated the LTBI care cascade among people who were recommended for TPT at the National Center for Tuberculosis and Lung Disease in four regions of Georgia such as: Kakheti, Kvemo Kartli, Shida Kartli and Imereti.

2. Methods

We conducted a prospective and retrospective cohort study looking at the implementation of preventive TB treatment in Georgia. The target group was in close contact with active



TB patients of any age and with other risk groups (HIV patients, Dialysis patients, Organ Transplant patients and cancer patients treated with TNF-alpha) during the year 2020-2022 as defined by the National treatment guidelines at National Center for Tuberculosis and Lung Disease (NCTLD) and three regions of Georgia, Kakheti, Imereti and Kvemo Kartli.

2.1 Settings and procedures

TB hot-spot contact investigation was performed by the National Center for Disease Control and Public Health (NCDC) epidemiologists. During contact investigation epidemiologists referred all close family contact to the specialized TB service clinics for further investigation and for ruling out active TB. In parallel, pulmonary TB patients were asked to bring their family and close contacts for investigation at specialized TB facilities. This was the countrywide practice including the National Center for Tuberculosis and Lung Disease.

After excluding active tuberculosis, TB contacts were consulted to receive preventive treatment. Preventive treatment regimen depended on the age group of contact person and drug sensitivity or resistance of index case. Children under 2 years, who were contacts of drug sensitive pulmonary TB cases are receiving 6 month INH therapy while, other contact persons were given Rifapentin for 3 months (12 doses). Contact persons with MDR index cases were recommended to start 6-month Levofloxacin (Lfx) treatment.

Baseline visit included tuberculosis skin test (TST) or Interferon-Gamma Release Assays (IGRA) assay, chest X-Ray and examination by a physician including a collection of anamnesis. Patients under treatment visited their personal physicians every month for further analysis and examination that included blood and urine tests and X-ray imaging if needed ("Detection and Treatment Latent Tuberculosis Infection in Georgia," n.d.).

2.2 Data collection

Special data collection tools (eCRFs) were developed for the primary data collection. The baseline form included socio-demographic information, details on co-morbidities and other risk factors for developing active TB diseases, TST status and information on chemoprophylaxis. A questionnaire was collected including "yes/no" or multiple choice questions. Data from 2020 were collected retrospectively to have complete data on new treatment regimens. Patients' medical charts were collected for informations relevant for research and are currently stored in TB units' archives. The subjects were followed for 1 year. The data were collected by the Research Electronic Data Capture - REDCap. The analysis was performed by the SPSS software. The univariable and bivariable analysis were performed to look at the potential risk factors for incidence of TB disease and barriers for Isoniazid Preventive Treatment (IPT) start/completion. The Mantel-Haenszel odds ratios (ORMH) and corresponding 95% confidence intervals were obtained as the measures of association. A multivariable logistic regression analysis was conducted and the relevant adjusted Odds Ratio OR will be obtained. Kaplan Meier survival analysis was performed for evaluating the time to TB disease incidence comparing between IPT and non-IPT groups.

2.3 Ethics

Permission for the study was obtained at the Local Ethics Committee of the National Center for Tuberculosis and Lung Diseases. Patients' informed consents were asked from all patients who underwent the ICF procedure. Only those who provided signed informed consent were considered in the study further based on eligibility criteria. All obtained informations were anonymized and unique identifiers were used for the records in the study database without possibility to identify the person. The electronic databases were kept on a password protected computer of the principal investigator. There were no direct benefits or any cash incentives to those individuals included in the study.

3. Results

At the first stage, we conducted a descriptive analysis, which took into account the number of recommended participants. The participants' sample included the information on how many of them started TPT, how many stopped and how many completed the preventive

treatment. An ongoing research aims to follow-up all participants every 3 months during 2023 to detect active TB cases from the national TB electronic database. After one year of follow-up period, the results were considered for further analysis looking for the effectiveness of the preventive treatment and treatment of active TB.

Among all 678-contacts of DS and DR TB cases and people from other risk groups, 54% were female and 46% male. 95 (14%) participants were from NCTLD, all other cases from other regions of Georgia (Kakheti, Kutaisi, Rustavi, Gori) (**Figure 1**). 22 Children under 5 years of age were recommended to have the TST test, among them 2 were TST positive. 72% from all participants had close contacts with index cases and were living in the same household. According to WHO, index case is defined as a person who has an active TB. A close contact is defined as living in the same household or in frequent contact with a source case with sputum smear-positive TB patient. 49% of index cases were culture positive and 45% were DST positive, 23 cases of index cases were MDR TB patients. Overall 164 (24%) persons from total 678 initiated TPT, among them 107 (65%) completed the treatment.

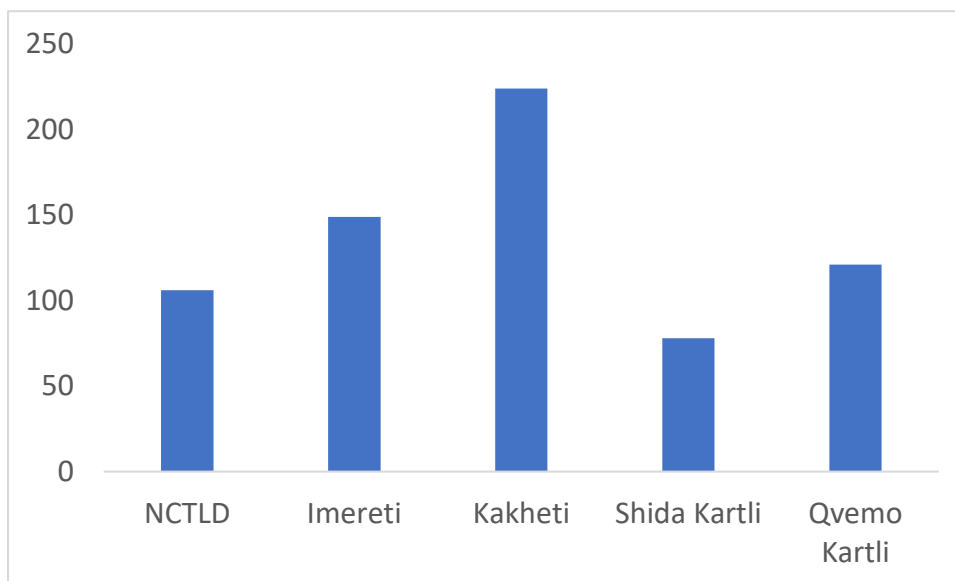

Figure 1. Distribution of test subjects over the regions.

4. Discussion

We found that 24% of subjects initiated the treatment of TB prophylaxis and from these, 65% completed the treatment. Due to the fact that we do not have comparable data from previous years, since the work of this program started for the first time in 2020, we cannot interpret the results as neither positive nor negative. We can compare only the results on children aged 0-5 years that were in close contact with TB patients with the results of a previous study, where the number of treatment initiation was 64% and among them 16% completed TPT. However, these data are also not relevant for comparison, as the children in the previous study were only prescribed 6 months of INH.

According to the systematic review of Sandgren et al. (2016) our completion rates were higher for the short LTBI treatment than for long LTBI treatment regimens. In the general population the reported initiation rate varied between 26–99 % and the completion rate between 39–96 %, In persons that were in close contact with TB patients initiation rate was 40–95 % and completion rate was 48–82 % (Sandgren et al., 2016). A study by Gullón Blanco et al. (2022) showed high rate of treatment initiation (86.6%, where only 12 persons refused to take part) while 262 (88.5%) completed 3 month TP. If we compare treatment completion rate (65%) with these results we are far from a high rate, but considering the novelty of a program we can estimate an increased number in the future.



5. Conclusion.

As our results show a low number of treatment initiation with unknown reasons for not entering into the program. Further research is needed to identify the issues of the programme. A qualitative research is planned to conduct in-depth analysis through the interviews with those participants who did not initiate or stopped the treatment.

Acknowledgments: Study was supported by European University at the bases of National Center for Tuberculosis and Lung Disease.

Conflicts of Interest: The authors declare no conflict of interest.

References.

1. Detection and Treatment Latent Tuberculosis Infection in Georgia. n.d.
2. Gabunia, T. 2019. Tuberculosis management in Georgia - guideline, 217. <https://www.moh.gov.ge/uploads/guidelines/2020/06/09/1550e0288cc7ca0e49c20652624645c0.pdf>
3. Global Tuberculosis Report 2020." n.d. Accessed September 2, 2021. <https://www.who.int/publications-detail-redirect/9789240013131>.
4. Global Tuberculosis Report 2022. n.d. Accessed January 9, 2023. <https://www.who.int/teams/global-tuberculosis-programme/tb-reports/global-tuberculosis-report-2022>.
5. Gullón Blanco JA, Rodrigo Sanz T, Álvarez Navascues F, Tabernero Huguet E, et al. Latent Tuberculosis Infection Treatment: Compliance and Factors Related with Initiation. *Arch Bronconeumol.* 2022; S0300-2896(22)00673-1. DOI: 10.1016/j.arbres.2022.12.011
6. LTBI Preventive Treatment in Children in Country of Georgia. n.d.
7. Sandgren A, Vonk Noordegraaf-Schouten M, van Kessel F, et al. Initiation and completion rates for latent tuberculosis infection treatment: a systematic review." *BMC Infect Dis.* 2016; 16: 204. DOI: 10.1186/s12879-016-1550-y
8. The REDCap Consortium: Building an International Community of Software Platform Partners. n.d. Accessed September 2, 2021. <https://www.ncbi.nlm.nih.gov/pmc/articles/PMC7254481/>. <https://login.emory.edu/idp/profile/SAML2/Redirect/SSO?execution=e1s1> (Harris PA, Taylor R, Minor BL, et al. The REDCap consortium: Building an international community of software platform partners. *J Biomed Inform.* 2019; 95:103208. DOI:10.1016/j.jbi.2019.103208) <https://login.emory.edu/idp/profile/SAML2/Redirect/SSO?execution=e1s1>
9. "WHO Operational Handbook on Tuberculosis: Module 1: Prevention: Tuberculosis Preventive Treatment." Accessed September 2, 2021. <https://www.who.int/publications-detail-redirect/9789240002906>.

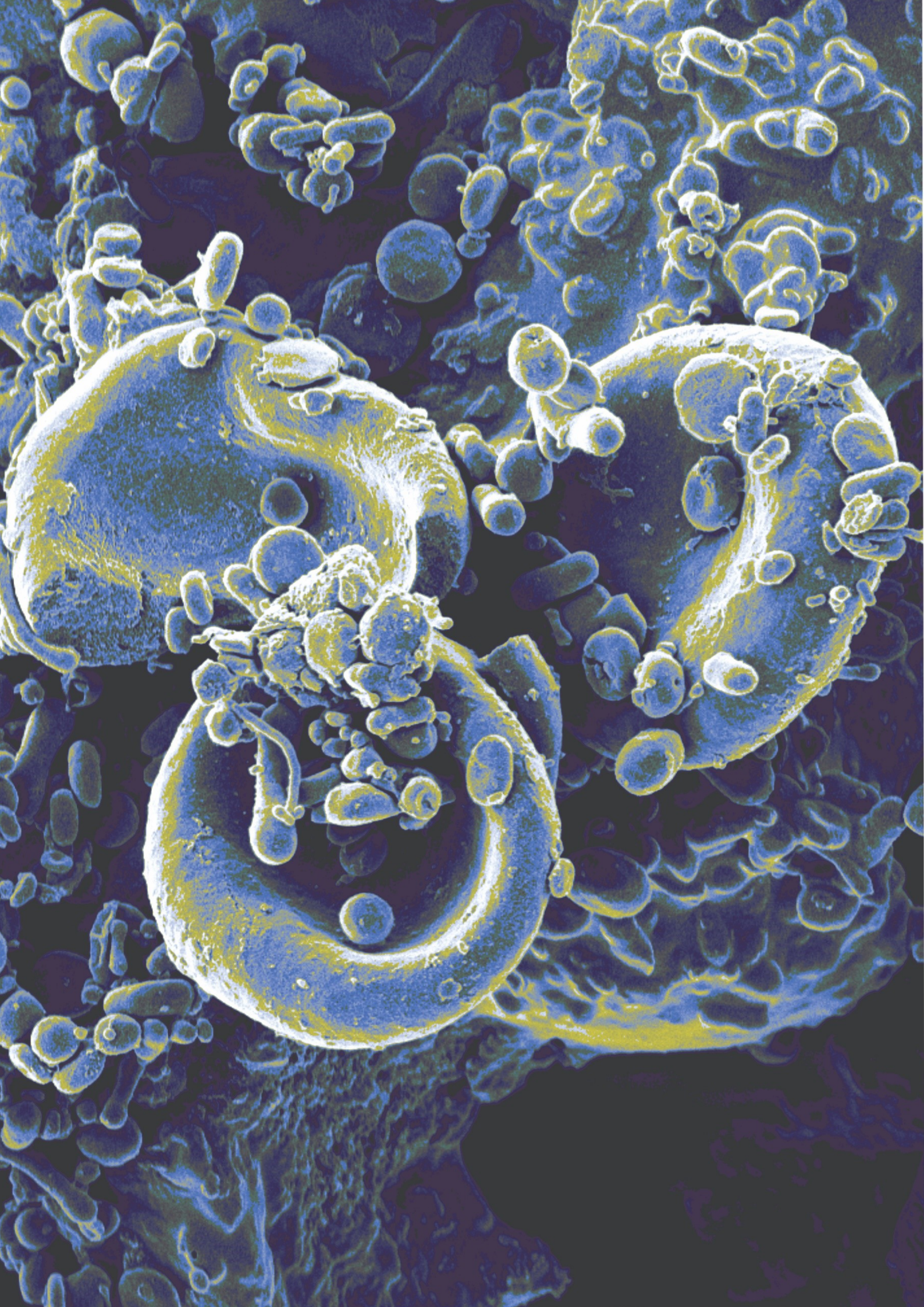

Impact of the preparation process of European spruce (*Picea abies*) homogenates and Common marigold (*Calendula officinalis*) isolates on total phenolic content

Luka Bonin¹, Jan Hafner Korošec¹, Tine Oblak¹, Maja Ponikvar-Svet¹,
Rigoberto Barrios-Francisco², Veronika Kralj-Iglič³, Martina Oder⁴, Marko Jeran^{1,*}

¹"Jožef Stefan" Institute, Department of Inorganic Chemistry and Technology, Ljubljana, Slovenia; ²Tecnológico Nacional de México/ITES de San Felipe del Progreso, División Ingeniería Química, San Felipe del Progreso, Mexico; ³University of Ljubljana, Faculty of Health Sciences, Laboratory of Clinical Biophysics, Ljubljana, Slovenia; ⁴University of Ljubljana, Faculty of Health Sciences, Department of Sanitary Engineering, Ljubljana, Slovenia
Correspondence: M.J., marko.jeran@ijs.si

OUTLINE

Plants have an incredible ability to synthesize many of the active ingredients on which today's medicines and therapies are based. They are able to defend themselves against external influences (enemies) by releasing the appropriate molecules into individual parts of plants¹. The spruce tree (*Picea abies*) and common marigold (*Calendula officinalis*) (Figure 1) contain different composition of biologically active and complex substances. The composition of these substances is based on several factors, e.g. geology, climate, time of harvesting, availability of nutrients, etc.

Polyphenols are compounds with one or more hydroxyl groups attached to the aromatic ring, which give them the ability to capture free radicals, moreover it gives them a stronger acidic character in comparison to other alcohol groups¹. This chemical reactivity is responsible for the antioxidant character of polyphenols. Nisca *et al.* (2021) have found a strong correlation between the antioxidant capacity and content of total polyphenols using ultrasound assisted extraction and microwave assisted extraction². The results also suggest that higher polyphenolic content may lead to a stronger antioxidant activity¹.

The focus of this work was determination of polyphenolic content in homogenates and/or isolates of spruce needles and common marigold, that are a source of cellular components and active compounds. The focus was put on different methods of preparation of homogenates and drug isolates preparation.

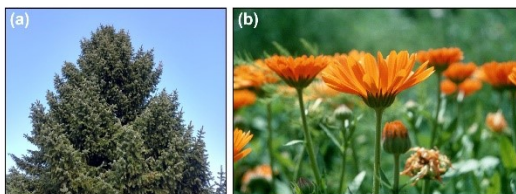

Figure 1: Plants: (a) European spruce (*Picea abies*) and (b) Common marigold (*Calendula officinalis*).

EXPERIMENTAL METHODS

An European spruce homogenates were prepared from the freshly collected needles in distilled water and physiological solution. For each individual experiment, 10.0 g of needles were weighed into a 100 mL Erlenmeyer flask and 20 mL of the medium – distilled water or saline (0.9% sodium chloride solution) was added. So prepared samples were exposed to various experimental conditions (Figure 2). Prior to the analysis, the contents were homogenized and the remaining needles were quantitatively filtered through a white ribbon paper (pore size 4.0–12.0 µm, Whatman) into a 50 mL falcon tube.

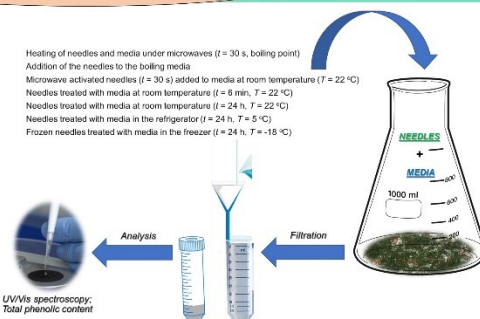

Figure 2: Flow chart of the experimental design for the preparation of homogenates from European spruce needles.

A **Common marigold** isolates were prepared by supercritical extraction and ethanol/water maceration. A 18 kg of marigold flowers were added into the reactor. The process was carried out under supercritical CO₂ environment, and the yield was 1 kg of the final isolate. The final isolate was stored in a dark place. For the ethanol/water maceration process, a 1 kg of plant leaves was treated overnight at room temperature in a 20% ethanol solution. The plant debris was filtered off, and the filtrate (1 kg) was stored in a dark place.

Total **phenolic contents** were determined according to Jeran *et al.* (2023) using the Folin-Ciocalteu method⁴ using the 96-well. A 12.5 µL of 10-times diluted Folin-Ciocalteu reagent (Sigma) was added to 2.5 µL aliquot of the sample and mixed. A 10 µL of 7.5% solution of sodium carbonate (≥ 99.5%, Sigma-Aldrich) was added and allowed to stand (t = 30 min) in dark at room temperature. The absorbance was assessed spectrophotometrically at 760 nm (Nanodrop One C, Thermo Scientific). A mixture of a 0.9% solution of sodium chloride (p.a., Sigma-Aldrich), and reagents was used as a blank. The calibration curve was prepared using gallic acid standard solutions (2–90 µg/mL). The results were expressed as mg of gallic acid per plant weight.

Particles in the water-based European spruce homogenates were heterogeneous in size thus they were visualized using **light microscopy** using a inverted light microscope (Nikon EM CCD Eclipse, TE2000-S, Nikon) with a digital camera system: spot boost (Visitron Systems).

RESULTS

The highest total phenolic content was detected in the direct microwave processing of the **spruce needle samples** in media to the boiling point (Figure 3). In this case 55.0 µg/g and 32.8 mg/g of polyphenols were found in distilled water and saline. The process was slightly slowed down after activation of the common extract by boiling media or at room temperature (T = 22 °C). Active compounds leached at low temperatures (refrigerator or freezer). The experimental tendency can be explained by the theory of Brownian particle motion – particles divide at higher temperature, move faster, and the higher temperature contributes to the opening of the pores of the plant tissue.

The technique of direct freezing of needles with media proved to be useless, as higher temperature appears to have a greater effect on leaching than deformation of the plant tissue by freezing and subsequent thawing. This again confirms the theory of Brownian particle motion that changes occur much more slowly at low temperatures than at higher temperatures.

Following the process of excretion of total phenolic compounds from plant tissues at different time periods (t = 6 min and 24 h), it was found that leaching into distilled water over a longer period of time is more effective; an increase from 15.2 to 28.2 µg/g was observed. In saline solution, the amount of total phenolic compounds decreased over time from 28.1 (t = 6 min) to 12.6 µg/g (t = 24 h). The reason for this could be the sensitivity of substances in the saline medium, as the pH of the medium may change with prolonged exposure to the needles, resulting in a decrease in total phenolic compounds due to formation of phenolates or decomposition. Another reason is a sensitivity to a pH. After an addition of the base (1 M NaOH) to the yellow colour sample the solution turned to a purplish brown. Conversely, the addition of an equal volume of a 1 M HCl solution to an alkaline solution turned the colour back to yellow. Since these are compounds with at least one aromatic ring containing one or more hydroxyl groups, the colour transition can be interpreted similarly to the natural dyes/indicators anthocyanins, which also belong to the polyphenols.

The highest total phenolic content was found in the water/ethanol extraction of **Common marigold** leaves (14.3 mg gallic acid/kg leaves), and the lowest content in the supercritical extract of flowers (0.0357 mg gallic acid/kg flowers). The reason is supercritical CO₂ extraction is used for extraction of lipophilic components of the sample, while the mixture of ethanol and water macerates mainly polar substances.

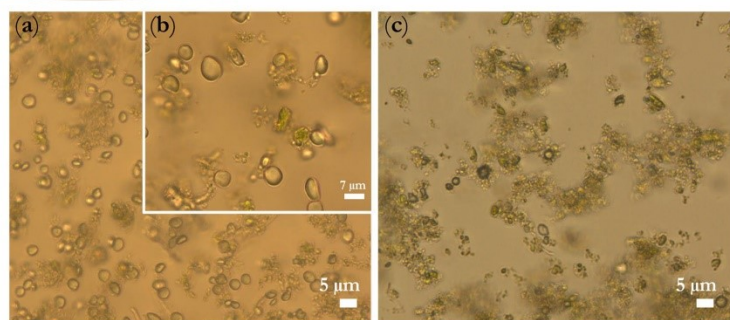

Figure 3: Homogenates in saline (a, b) and in distilled water (c) have the same structural fragments, but the concentration of membrane-enclosed particles is higher in the saline. In the aqueous homogenate (c), the particles were located in the clusters, where some deformed plant cells can be seen, among others.

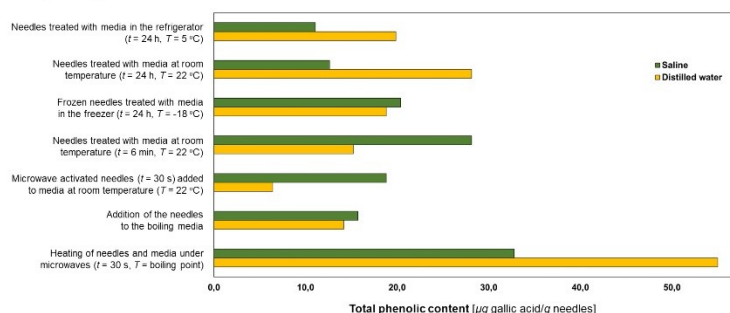

Figure 4: Total phenolic content in homogenates of European spruce (*Picea abies*) needles.

CONCLUSION

Experiments have shown that **factors** such as the choice of isolation method, plant part, temperature, time, and choice of medium have a **significant effect** on the extraction and quantitative content of total phenolic content.

This research was supported by the Slovenian Research Agency (ARRS) through the Core Findings no. P1-0045 and P3-0388.

REFERENCES

- Jeran M, Pločan L, Barrios-Francisco R. Interdisciplinary insight on European Spruce (*Picea abies*): Biologically active compounds and their usage. *Proceedings of Socratic Lectures*. 2021; 6: 64-70. DOI: <https://doi.org/10.55285/PSL.2021.D.009>
- Nisca A, Stefanescu R, Stegăruş D, Mare AD. Phytochemical profile and biological effects of spruce (*Picea abies*) bark subjected to ultrasound assisted and microwave-assisted extractions. *Plants*. 2021; 10(5): 870. DOI: <https://doi.org/10.3390/plants10050870>
- Jeran M, Romolo A, Spasovski A, Hočevar M. Small cellular particles from European spruce needle homogenate. *Int. J. Mol. Sci.* 2022 (submitted).



Decoding Feline Emotional-Motivational Systems, Emotions and Behaviour in Marketing

Pšenica Kovačič

Minami Kat, Center for Cat Culture, www.minamikat.si, info@minamikat.si

OUTLINE	EXPERIMENTAL METHODS	CONCLUSION
<p>Cats are a viral phenomenon in pop visual culture, like memes, funny videos and also in marketing. They are also popular in the film, cartoon, comic and game industries as main or supporting characters. There is something mysterious, elegant, cute and funny about them that resonates with cat owners and carers as well as consumers. As a result, cats are often used for promotional purposes, be it for a cat product or (non-)cat service, product or the film and games industry.</p>	<p>We have considered some typical or common visual images of cats that appear in information messages or advertisements for cat magazine sales promotions, cat shows, cat service provider advertisements and information for cat protection associations or institutions. We looked at the overall visual image, the verbal text and, of course, the emotional motivational states based on the cats' body language and facial expressions or their authenticity in the context of the situation.</p>	<p>A comparative analysis of better and worse examples showed that in most areas there is a range from ignorant unwillingness to intentional ignorance or entrenchment in one's beliefs and values or marketing goals and what sells better. I believe that regaling people with "cute" but inauthentic cat images and funny or emotional (sub-)messages is harmful to both the cat and the people. Only by maintaining superficiality and shallowness, rather than information and sobriety.</p>

What to observe in feline body language and facial expressions

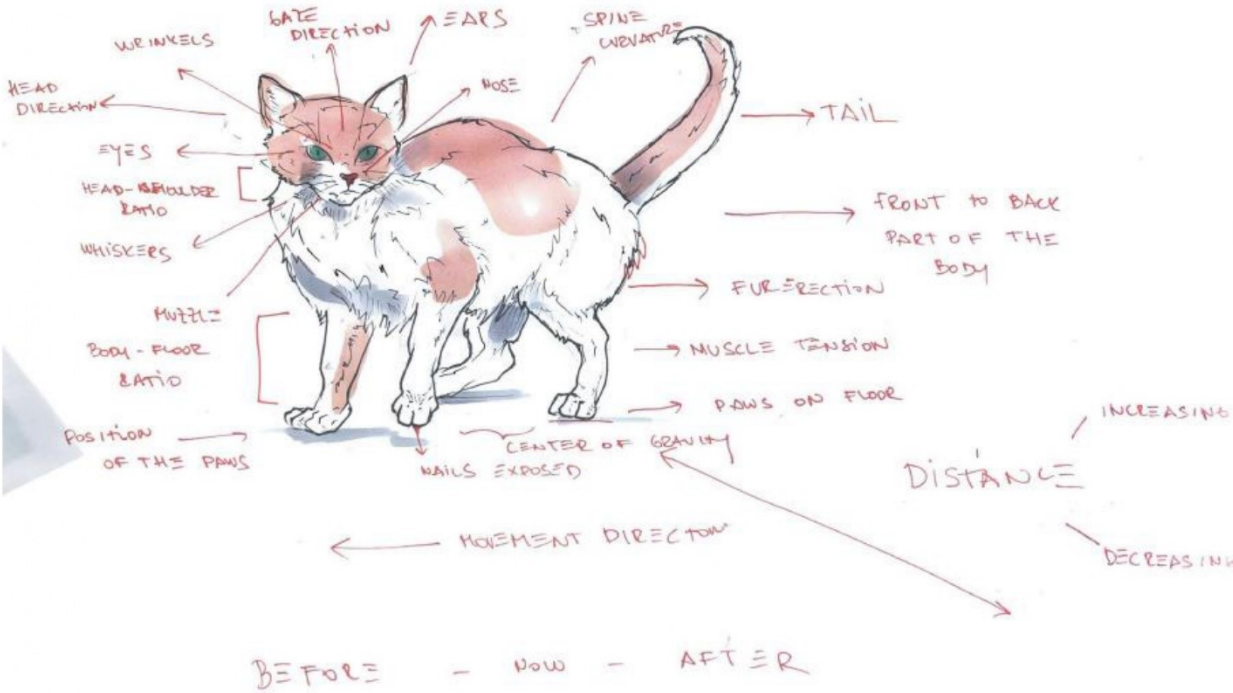

Figure 1: Artist: Psenica Kovacic BFA



Thermography as an aid in the performance testing of Lipizzan horses

Peter Kruljč

University of Ljubljana, Veterinary Faculty, Clinic for Reproduction and Large Animals,
Gerbičeva 60, 1000 Ljubljana, Slovenia
Contact: peter.kruljč@vf.uni-lj.si

OUTLINE

The athletic results or training performance of Lipizzan horses are hardly known in equestrian sports. Body skin temperatures (BST) at rest were different between different areas or body parts. After the work test, temperatures in all body skin areas were significantly elevated compared to those measured at rest and then decreased during the rest period after the work test. This study contributes to the knowledge of thermoregulation and the use of thermography in horses, and the results not only demonstrate the physiological responses to graded exercise in Lipizzaners, but also contribute to equine physiology and sports medicine.

The aim of this study was to determine the values of physiological parameters with emphasis on the temperature changes of the body skin areas by thermography and to investigate their acclimatization to different training loads.

METHODS

Horses : The study was performed with 6 pure-bred Lipizzans with a mean (\pm Standard Deviation (SD)) age of 9.0 ± 0.8 years and a mean (\pm SD) body mass of 455 ± 36 kg.

Test protocol and physical activity: The study consisted of two exercise tests, performed by lunging in riding indoor arena. The first test was implemented in May and the second one in October. The exercise test protocol consisted of 8 phases with specific activities (lunging at the walk, trot and canter or resting) and measurements of physiological values (BSTs of various body regions) and environmental parameters (air temperature and humidity). Each test was preceded by a 5-minute walk stable to the riding arena (Phase 1; P-1) and a 10 min. rest (Phase 2; P-2). Each horse was then lunged for 30 minutes at the walk, trot and canter (for 10 minutes at each gait), and left and right reins were exchanged every 5 minutes (Phase 3 to Phase 5; P-3 to P-5). This was followed by a 10-minute break (Phase 6; P-6) intended for the repetition of the measurements and then by 10 minutes of lunging at the walk (Phase 7; P-7). Thereafter, each horse was returned to its stall (Phase 8; P-8), and the measurements were repeated again.

CONCLUSIONS

The results of our study represent the physiological response of Lipizzan horses to graded exercise and can be considered an important contribution to sports physiology and medicine in relation to the Lipizzan breed. This study also contributes to the knowledge of equine thermography in different seasons and to the recognition of the complex physiological processes during exercise, which provide a basis for further research in the field of equine exercise testing and sports medicine.

RESULTS

The mean (\pm SD) distances covered during the exercise tests in May and October were 794 ± 25 m and 785 ± 78 m at the walk and 1851 ± 38 m and 1828 ± 48 m at the trot, respectively, and 3089 ± 10 m and 2432 ± 81 m ($P < 0.05$) at the canter. Temperature and air humidity are presented in Table 1.

Table 1: Air temperatures and air humidity (mean \pm SD) before exercise (P-2), immediately after exercise (P-6) and during recovery (P-8) of the May and October tests

PARAMETER	TRIAL	PHASE		
		P-2	P-6	P-8
Air temperature [°C]	May	18.42 \pm 0.77 ^a	21.10 \pm 0.77 ^a	21.27 \pm 0.68 ^a
	October	11.38 \pm 0.70 ^a	11.95 \pm 0.73 ^a	12.48 \pm 0.71 ^a
Air humidity [%]	May	62.48 \pm 4.32 ^b	55.33 \pm 3.94 ^c	50.63 \pm 4.20 ^b
	October	81.47 \pm 4.62 ^b	85.80 \pm 4.78 ^c	84.15 \pm 5.09 ^b

^{a,b,c} $P < 0.001$; ^{a,b} $P < 0.01$ for values in the same column

A significant increase in BSTs was noted immediately after the exercise test (P-6) compared with basal values (P-2) in May ($P < 0.001$ for buttocks, chest, and neck, $P = 0.003$ for croup, and $P = 0.005$ for back) and in October ($P < 0.0001$ for all regions). In October, a significant decrease in BSTs was observed when comparing P-6 and P-8 ($P = 0.05$ for buttocks, $P = 0.016$ for neck, $P = 0.001$ for back, $P = 0.003$ for chest), but the difference for back was insignificant ($P = 0.095$).

Table 2: Changes in the body skin temperature of various body regions before the exercise test (Phase 2; P-2), immediately after the exercise test (Phase 6; P-6) and during the recovery (Phase 8; P-8) in both periods (May and October).

BODY REGIONS	MONTH	AVERAGE BODY SKIN TEMPERATURE (BST) °C		
		P-2	P-6	P-8
Buttocks	May	30.2 \pm 0.6 ^{A,B}	33.4 \pm 1.6 ^{A,B}	33.6 \pm 1.1 ^{A,B}
	October	26.8 \pm 1.8 ^a	32.6 \pm 0.7 ^a	30.7 \pm 0.7 ^{a,b}
Croup	May	26.5 \pm 1.5	29.6 \pm 2.1	30.5 \pm 1.8
	October	22.7 \pm 2.2	27.5 \pm 2.2	26.1 \pm 2.3
Back	May	27.7 \pm 1.3	30.6 \pm 2.3	31.4 \pm 1.3
	October	24.1 \pm 1.5	29.1 \pm 1.3	27.5 \pm 1.4 ^c
Chest	May	30.4 \pm 1.8 ^A	34.0 \pm 2.7 ^{A,B}	33.6 \pm 1.4 ^{A,B}
	October	28.7 \pm 1.1 ^b	34.9 \pm 1.3	32.0 \pm 1.5 ^a
Neck	May	29.8 \pm 1.6 ^A	33.1 \pm 2.0 ^{A,B}	33.1 \pm 1.3 ^B
	October	28.0 \pm 1.7 ^{a,b}	32.5 \pm 2.0 ^a	30.2 \pm 1.5 ^b

^{A,B} $P > 0.05$ for values in a row with the same labels; other combinations of values for May in the same column are significantly different ($P < 0.05$)
^{a,b} $P > 0.05$ for values in a column with the same labels; other combinations of values for October in the same column are significantly different ($P < 0.05$)



Thermogram of the Lipizzan horse

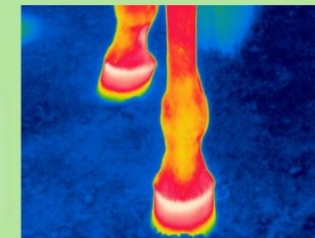

Thermogram of the forelegs of the Lipizzan horse

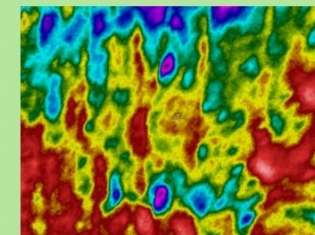

Neck thermogram of a Lipizzan horse after training

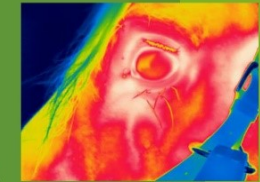

REFERENCES

- Čebulj-Kadunc N, Frangež R, Kruljč P. Infrared thermography in equine practice. *Veterinarska stanica : znanstveno-stručni veterinarski časopis*. 2020, vol. 51, no. 2, str. 109-116.
- Turner TA. Diagnostic thermography. 2001; *Vet Clin North Am Equine Pract* 17, 95 - 113.
- Soroko M, Dudek K, Howell K, Jodkowska E, Henkleski R. Thermographic evaluation of racehorse performance. 2014; *J Equine Vet Sci* 34, 1076 - 1083.
- Westermann S, Stanek C, Schramel JP, Ion A, Buchner HH. The effect of airflow on thermographically determined temperature of the distal forelimb of the horse. 2013; *Equine Veterinary Journal* 45, 637-641.
- Čebulj-Kadunc N, Frangež R, Kruljč P. Fluctuations of physiological variables during conditioning of Lipizzan fillies before starting under saddle. *Animals*. 2022, vol. 12, no. 7, art. 836, str. 1-15.



Thermogram of a Lipizzan horse with trainer

ACKNOWLEDGEMENTS

The authors acknowledge the financial support of the Slovenian Research Agency (Research program P4-0053).

Comparison of the Folin-Ciocalteu and 4-aminoantipyrine spectrophotometric methods for the determination of total phenolic content in tea infusions

Anja Pavlovič^{1,2,*}, Marko Jeran¹, Maja Ponikvar-Svet^{1,2}

¹ "Jožef Stefan" Institute, Department of Inorganic Chemistry and Technology, Ljubljana, Slovenia

² "Jožef Stefan" International Postgraduate School, Ljubljana, Slovenia

Correspondence: A.P., anja.pavlovic@ijs.si



OUTLINE

Tea is the most consumed beverage in the world next to fresh water. It is a rich source of biologically active molecules, such as polyphenols, which are believed to have various health benefits in the prevention of cancer, hypertension and obesity. However, the plant *Camellia sinensis* L. is also a hyperaccumulator of fluorine (F) and aluminium (Al), the levels of which are many times higher than in other edible plants¹.

Previous studies have shown that the F and Al content in tea increases with the maturity of the tea shoots. Furthermore, significant negative correlations were found between the F and Al content and the content of the quality parameters total polyphenols and amino acids². Due to the different processing methods, the total phenolic content per serving is much higher in green tea than in black tea. Therefore, green tea can be expected to have greater health benefits in terms of antioxidant capacity than an equal amount of black tea³.

The aim of our study was to compare the results of the determination of total polyphenols in black and green tea infusions by two spectrophotometric methods and to determine whether the polyphenol content decreases with higher levels of F and Al. In doing so, we wanted to confirm that the content of F, Al and total polyphenols can be used as a quality indicator for the evaluation of tea.

EXPERIMENTAL METHODS

Selection and preparation of the samples

For analysis, we selected 2 of the best-selling black and green teas in filter bags in Slovenia. Samples were prepared according to the procedure of *Koblar et al.*⁴ The analysis was performed on duplicate sample portions. Concentrations in each portion were measured at least twice. The accuracy of the analyses was checked by using appropriate standard materials.

Direct Potentiometry

For the potentiometric determination of fluoride ions (F⁻), the 906 Titrand system (Metrohm) with 9609BNWP Orion ion selective electrode (Thermo Scientific) calibrated at 10 and 50 µg/ml standard solutions of F⁻ was used.

Inductively coupled plasma – optical emission spectroscopy (ICP-OES)

Al concentrations were determined with ICP-OES in axial view. Prior to measurement, the samples were acidified. A 1.2 ml conc. HNO₃ was added to 50 ml of the tea infusion to convert the aluminium species into more soluble nitrate salts. The system was calibrated using standard solutions with concentrations between 0.005 and 5 µg/ml.

Spectrophotometry

Total phenolic content was determined spectrophotometrically by two different methods. **Folin-Ciocalteu method (F-C):** 2.5 µL sample was mixed with 12.5 µL F-C reagent and 10 µL 7.5% aqueous sodium carbonate solution. The mixture was allowed to stand in the dark at room temperature (t = 30 min). The absorbance was measured at 760 nm using Nanodrop One C (Thermo Scientific). The calibration curve was constructed using gallic acid standard solutions (2–90 µg/mL). The results were expressed as mg of gallic acid per plant weight. **4-aminoantipyrine method:** A 50 mL of the sample was added into a 250 mL separatory funnel. A 5 mL of Hardness Buffer, Phenol Reagent Powder Pillows (all from HACH) and 30 mL of chloroform were added. After extraction, the phenols concentration in the organic phase was measured at 460 nm using the DR3900 spectrophotometer.

REFERENCES

- (1) Pavlovič A, Ponikvar-Svet M. Risk Assessment of Fluoride and Aluminium Intake from Tea in Slovenia. In: Pintar A (editor), 28th Annual Meeting of the Slovenian Chemical Society. 2022, 112. ISBN 978-961-95922-1-2.
- (2) Lu Y, Guo WF, Yang XQ. Fluoride Content in Tea and Its Relationship with Tea Quality. *J. Agric. Food Chem.* 2004, 52, 4472–4476. DOI:10.1021/JF0308354.
- (3) Lee KW, Lee HJ, Lee CY. Antioxidant Activity of Black Tea vs. Green Tea. *J. Nutr.* 2002, 132, 785–785.
- (4) Koblar A, Tavčar G, Ponikvar-Svet M. Fluoride in Teas of Different Types and Forms and the Exposure of Humans to Fluoride with Tea and Diet. *Food Chem.* 2012, 130, 286–290. DOI:10.1016/J.FOODCHEM.2011.07.037.
- (5) Khan N, Mukhtar H. Tea Polyphenols for Health Promotion. *Life Sci.* 2007, 81, 519–53. DOI:10.1016/J.LFS.2007.06.011

RESULTS

Determination of F and Al content

The systems used for determination of concentration of F and Al species in tea infusions are shown in Figure 1.



Figure 1: Potentiometric and ICP-OES system

Total content of F and Al in tea infusions of black (BF) and green (GF) tea in filter bags are presented in Figure 2.

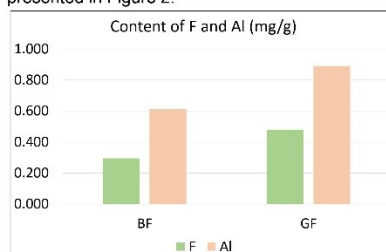

Figure 2: Total content (mg/g) of F and Al in BF and GF (n = 2)

Black tea in filter bags (BF) contains significantly higher content of F and Al than green tea in filter bags (GF). This indicates BF quality is worse and less healthy for humans.

INTERPRETATION OF RESULTS

According to our results, black tea in filter bags contains higher contents of F and Al than green tea. The main reason for the differences can be ascribed to the age of the tea leaves and the fermentation process, which is different for each type of tea. Black teas are usually made from older leaves – the older individual tea leaves become, the more fluoride and metals they may contain.

Both elements (F, Al) seem to be correlated – the higher the fluoride concentration, the higher the aluminium concentration.

The phenolic content in tea refers to phenols and polyphenols, natural plant compounds present in tea, which greatly affect the taste and mouthfeel of tea. Polyphenols in tea include catechins, theaflavins, tannins and flavonoids. A tea infusions prepared at a ratio of 1 g of leaf to 100 ml of water usually contains 250–350 mg of solids, composed of 30–42% catechins and 3–6% caffeine⁵. Therefore, the total phenolic content in tea infusions should be between 75–147 mg.

The comparison of the two methods used showed that the F-C method is more suitable than the 4-aminoantipyrine method. The phenolic content determined with the F-C reagent ranged between 44–69 mg/g, while the phenolic content determined with the 4-aminoantipyrine reagent was less than 0.01 mg/g. This difference can be explained by the tea matrix. While the F-C method is probably the most widely used method for the spectrophotometric determination of total phenolic content in liquid and solid organic matrices, the employed 4-aminoantipyrine method has been proposed (by HACH) for the determination of phenols and all substituted phenols (except those with para substitution) in wastewater.

Determination of total phenolic content

Total phenolic contents in infusions of BF and GF were determined with F-C and 4-aminoantipyrine method (Figure 3).

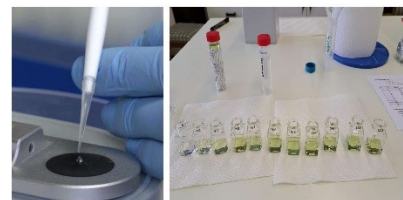

Figure 3: F-C and 4-aminoantipyrine method

Table 1: Total phenolic content (mg/g) determined with spectrophotometric F-C and 4-aminoantipyrine method (n = 2)

Tea infusion	Total phenolic content (mg/g)	
	Folin-Ciocalteu	4-aminoantipyrine
BF	68.667	< 0.01
GF	44.062	< 0.01

The results of the determination of phenolic content in infusions of black and green tea are shown in Table 1. Higher contents of polyphenols were determined using the "classical" F-C method than with 4-aminoantipyrine method. The results obtained with the latter method were even lower than the detection limit of the method. As shown, black tea in filter bags (BF) contains significantly higher content of polyphenols compared to green tea in filter bags (GF).

CONCLUSION

Our results confirm that the Folin-Ciocalteu method, although it is not selective, is a method of choice for the spectrophotometric determination of the total phenolic content of plant-derived food and biological samples, including tea.

The hypothesis that the phenolic content in black and green tea infusions decreases with higher contents of fluoride and aluminium ions remains unconfirmed. It is recommended that more samples be included in the study and that further studies be conducted with tea samples of comparable variety (not aromatized as opposed to aromatized).

Incorporation of non canonical amino acids into pore-forming proteins using genetic code expansion

Gregor Spruk¹, Gregor Anderluh¹, Ana Crnković¹

¹Department of Nanobiotechnology and Molecular Biology, National Institute of chemistry, Slovenia
Contact: Gregor.Spruk: gregor.spruk@ki.si

OUTLINE

Nanopore sensing is an analytical method that allows detection of single molecules by identifying changes in the ionic current flowing through the pore. As an analyte traverses the pore, a characteristic decrease in ion current is observed due to volume exclusion and binding of ions to the traversing analyte¹. Protein pores are typically used for this purpose, but some sensing applications must be performed under harsh conditions that would denature protein pores.

We hope to solve this problem by using **genetic code expansion** (GCE). This method allows the incorporation of over 200 chemically and structurally diverse non canonical amino acids (ncAAs) into target proteins². Halogenated ncAAs have been used to increase protein stability at elevated temperatures and in the presence of denaturants^{3,4}. The goal of our work is to incorporate halogenated ncAAs into pore-forming proteins so that they can be used for nanopore sensing under harsher conditions.

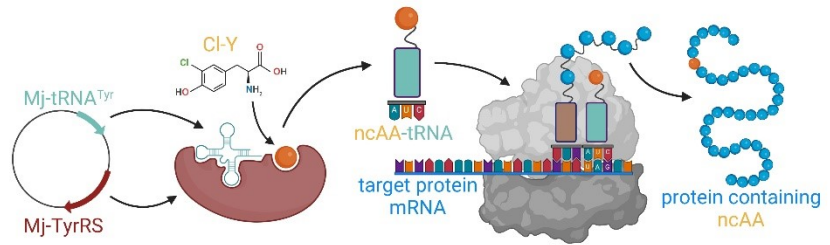

Figure 1: Schematic representation of genetic code expansion using stop codon reassignment, using a mutant tyrosyl-tRNA synthetase from *Methanocaldococcus jannaschii* (Mj-TyrRS) and its cognate tRNA to introduce *m*-Cl-tyrosine (Cl-Y) into the target protein bearing an amber stop codon.

EXPERIMENTAL METHODS

We used **stop codon reassignment** to incorporate Cl-Y and *p*-pentafluorosulfanyl-phenylalanine (SF5-F) into bryoporin (Bry) monomers at the desired positions. Bry expression was induced with isopropyl β-D-1-thiogalactopyranoside (IPTG) in *Escherichia coli*. We tested the specificity of Cl-Y incorporation into the protein using **Western blot** and the solubility of the produced proteins with sodium dodecyl sulfate-polyacrylamide gel electrophoresis (**SDS-PAGE**). The two most soluble variants were then purified by nickel-nitrilotriacetic acid (NiNTA) **chromatography** and their pore-forming activity was investigated by **hemolysis**. In the future, we will also characterize the SF5-F variants of Bry, investigate the stability of the pores formed by our proteins using circular dichroism measurements, and verify the presence of ncAAs in our proteins using mass spectrometry.

CONCLUSION

Cl-Y can be incorporated into Bry with high efficiency and without major loss of pore-forming activity. However, whether the stability of the pore complexes is improved by incorporation of halogenated ncAAs remains to be tested.

REFERENCES

- Crnković A., Srnko M., Anderluh G. (2021). Biological Nanopores: Engineering on Demand, *Life*, 11, 27. Doi: 10.3390/life11010027
- Dumas A., Lercher L., Spicer C. D., Davis B. G. (2015). Designing logical codon reassignment-Expanding the chemistry in biology, *Chemical Science*, 6, 1, 50–69. Doi: 10.1039/c4sc01534g
- Carlsson A., Scholfield M. R., Rowe R. K., Ford M. C., Alexander A. T., Mehl R. A., Ho P. S. (2018). Increasing Enzyme Stability and Activity through Hydrogen Bond-Enhanced Halogen Bonds, *Biochemistry*, 57, 28, 4135–4147. Doi: 10.1021/acs.biochem.8b00603
- Ohtake K., Yamaguchi A., Mukai T., Kashimura H., Hirano N., Haruki M., Kokashi S., Yamagishi K., Murayama K., Tomabechi Y., Itagaki T., Akasaka R., Kawazoe M., Takemoto C., Shirouzu M., Yokoyama S., Sakamoto K. (2015). Protein stabilization utilizing a redefined codon, *Scientific Reports*, 5, 9762. Doi: 10.1038/srep09762

ACKNOWLEDGEMENT

This work received funding from the Slovenian Research Agency grants P1-0391, J4-8225, and J4-2547 (to G.A.) and the European Union's Horizon 2020 programme under the Marie Skłodowska-Curie grant agreement No. 896849-nanoEx (to A.C.).



RESULTS

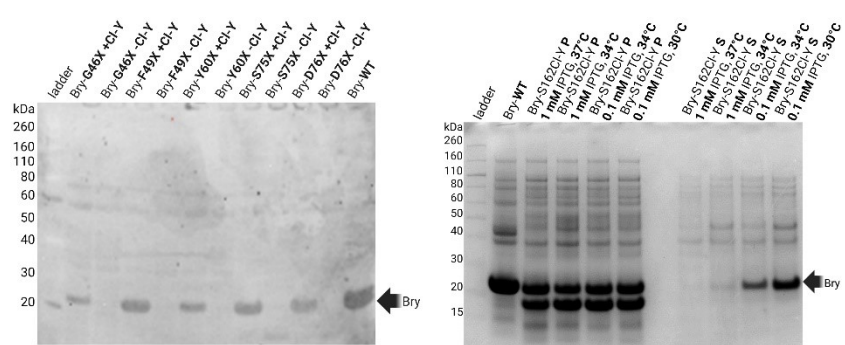

Figure 2: Western blot analysis of *E. coli* lysates expressing mutant Bry. Cl-Y is inserted in place of an amber stop codon using the mutant Mj-TyrRS and its cognate tRNA. In samples labeled +, the Bry mutant was expressed in the presence of Cl-Y, which was successfully incorporated into the protein, whereas in samples labeled -, it was expressed in the absence of Cl-Y. This assay confirms that Mj-TyrRS incorporates only Cl-Y into Bry and no other amino acid.

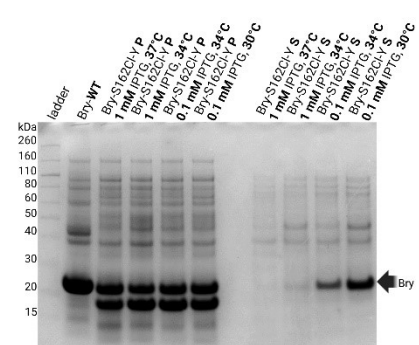

Figure 3: SDS-PAGE of solubility optimization of Bry-S162Cl-Y. *E. coli* lysates were centrifuged, their supernatants and pellets separated from each other, and then loaded onto the gel. The expression conditions of each sample are noted in the figure; pellets are labeled P, whereas supernatants are labeled S. Strong bands under the Bry bands in the pellet samples represent the truncated protein where translation was terminated at the stop codon instead of Cl-Y being inserted.

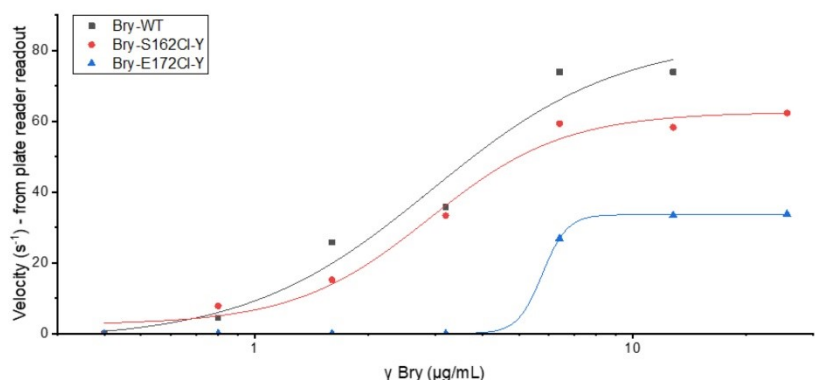

Figure 4: Hemolytic activity of wild-type Bry and the variants with incorporated Cl-Y. Activity was measured as the change in absorbance of light with a wavelength of 630 nm. The samples contained different concentrations of each protein. As the proteins lysed the erythrocytes, the decreasing absorbance of the samples was measured at regular time intervals. In the graph, activity is shown as the maximum change in absorbance between two consecutive measurements in each sample, i. e., velocity. The Bry-S162Cl-Y variant has similar activity to wild-type Bry, while the Bry-E172Cl-Y variant is less active but still able to lyse cells.

Interdisciplinary informal education approach for sustainable knowledge among primary and secondary school students via a scientific research institution

Melita Tramšek, Evelin Gruden, Marko Jeran*

"Jožef Stefan" Institute, Department of Inorganic Chemistry and Technology, Ljubljana, Slovenia

Correspondence: marko.jeran@ijs.si



OUTLINE

Chemistry is the driving force behind various branches of science and industry. It provides answers to important questions about life, the environment, new materials and (alternative) energy sources. These areas of research involve a strongly interdisciplinary approach, where experts have to deal with a variety of practical challenges. The interdisciplinary approaches in science require the education system to equip the younger generations with the knowledge and skills to network and communicate in science. Later in life, they can hone their skills during their studies and professional development. It is important to inspire students through various events and content to help them reach their full potential.

About 30 years ago, the *School of Experimental Chemistry* programme was established in the premises of the "Jožef Stefan" Institute as a tool to promote science. The programme is jointly organised by the "Jožef Stefan" Institute and the *Slovenian Society of Chemistry Lovers* ("Slovensko društvo ljubiteljev kemije") and its main goal is to awaken interest in chemistry among young people¹.

CONNECTED ACTIVITIES

The *School of Experimental Chemistry* programme has become a major player in promoting science at various events. For years it has been well received at the annual Slovenian Science Festival, organised by the Slovenian Science Foundation, and since 2018 also at the European Researchers' Night. The colleagues from the "Jožef Stefan" Institute are actively involved in various performances in kindergartens, primary and secondary schools and organise the *Summer School of Experimental Chemistry* during school holidays.

METHOD

In our study, a qualitative questionnaire was distributed to a randomly selected group of primary school students to observe their motivation ($N = 12$). The sample consisted of participants in the *Summer School of Experimental Chemistry*. The group consisted of 75% boys and 25% girls who had the highest grades in science and chemistry (67% excellent and 33% very good). 67% of the subjects were highly motivated for natural science and technology, while the rest were more interested in social sciences and arts. Each of the students could choose the statement that best suited them for the first ten questions, while they could also express their opinion for the following four questions.

RESULTS

The analysis showed that all children like experiments, especially those that involve various physical and chemical changes and those that are classified as dangerous experiments. Somewhat less popular are experiments in which candidates make their own measurements and calculations. However, older and more enthusiastic students prefer to do individual experiments, to learn more complex procedures and experience what the work of a real chemist is like.

In general, students miss experimentation in primary schools. Some teachers do conduct demonstration experiments to some extent, but opportunities for individual experimentation are still limited. In their opinion, activities like the *Summer School of Experimental Chemistry* are very welcome.

Often students tend to return to the *School of Experimental Chemistry* year after year. The young people are very aware of the importance of such training. On the one hand, the knowledge imparted by the researchers gives them content that is not part of the regular curriculum. On the other hand, the school is a friendly environment where the students find contacts with like-minded people who share their joy and interest in experiments and science. They also practise their speaking skills when presenting experiments to their classmates.



Figure 1: Demonstration experiments by individual students. (a) Preparation of different solutions of food colouring in sodium alginate to form alginate microspheres. (b) The result of adding alginate solutions with food colouring in water – formation of a chemical slime in the water medium. (c) Paper chromatography of the watercolour marker. (d) Golden drawing: reaction between iron(III) chloride and potassium thiocyanate on filter paper. (e) Golden rain demonstration: precipitation of lead(II) iodide as a result of the reaction between lead(II) acetate and potassium iodide in aqueous medium.

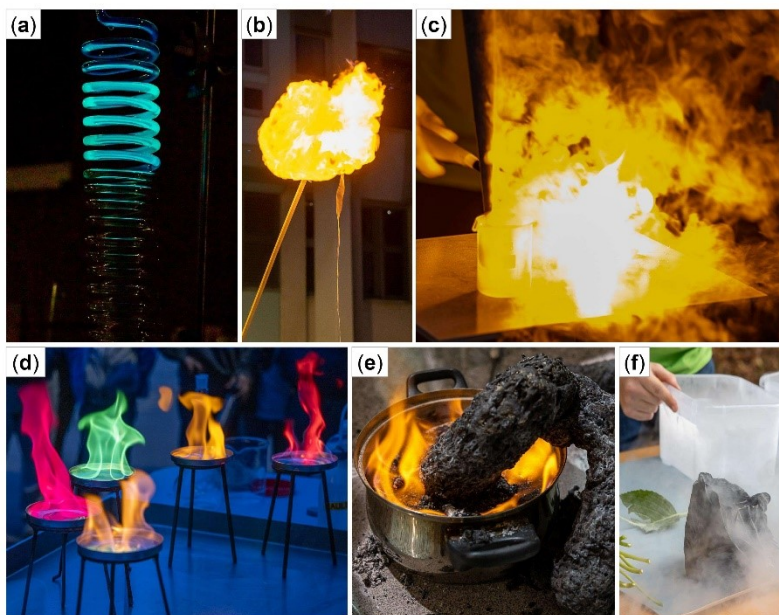

Figure 2: Demonstration of attractive experiments at the European Researchers' Night. (a) The journey of the chemiluminescence reaction in the coil assembly. (b) Hydrogen balloon explosion and (c) Ignition of dry bread soaked in condensed air enriched with oxygen. (d) Flame reactions of metal ions and (e) Sugar snake in which a white tablet of a mixture of sucrose and sodium bicarbonate slowly burns and eventually turns black as the snake grows. (f) Illustration of the properties of liquid nitrogen ($-196\text{ }^{\circ}\text{C}$).

CONCLUSION

The *School of Experimental Chemistry* is a programme for the promotion of science. Our study has shown that it is particularly suitable for primary and secondary school students who enjoy chemistry, want to conduct experiments independently and deepen their knowledge of chemistry on a theoretical and experimental level.

The "Jožef Stefan" Institute researchers involved in the programme work with primary and secondary school teachers and support them in developing experiments and scientific methods suitable for school use.

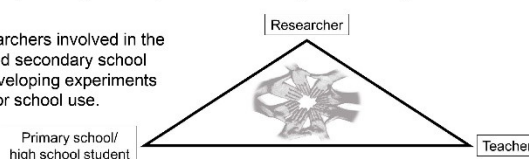

Figure 3: The connection between the central actors of the triangle "primary school/ high school student – teacher – researcher" is decisive for the integration and for the sustainability of the knowledge in the interdisciplinary integration.

Reference: [1] Tramšek M, Gruden E, Jeran M. *Acta Chimica Slovenica*, 2022, 69(4), s95–s97. DOI: 10.17344/acsi.2022.7868

ACKNOWLEDGEMENTS

This research was supported by the Slovenian Research Agency (ARRS) through core research programme P1-0045 and by the *Slovenian Society of Chemistry Lovers* for its educational activities and programmes for youth. We thank Mr. Marjan Verč for photography of the experiments. Special thanks goes to everyone who has contributed to the development of *School of Experimental Chemistry* in any way.