

## Daggers of the Dangstetten type

Janka ISTENIČ

### Izvleček

Za doslej neidentificirano skupino bodal s polkrožnim glavičem so značilne medeninaste zakovice z glavicami, ki imajo dvignjen rob in bunčico v sredini; značilnost njim pripadajočih polnokovinskih nožnic so poleg enakih zakovic še medeninaste zanke za pripenjanje. Največ takih bodal in nožnic izvira iz rimskega vojaškega tabora Dangstetten, zato predlagamo njihovo poimenovanje po tem najdišču.

Opisana bodala in nožnice izvirajo z najdišč in iz kontekstov, ki kažejo na datacijo od konca zgodnjeav-gustejske oziroma začetka srednjeav-gustejske do konca poznoav-gustejske dobe.

**Ključne besede:** bodala, nožnice, avgustejska doba, zakovice, medenina, Dangstetten, Ljubljana

### Abstract

Typical of an as yet unidentified group of daggers with a semicircular pommel are distinctive brass rivets with heads decorated with a raised edge and a small raised circle in the center. Such rivets, together with brass suspension loops, are also characteristic of the associated sheaths constructed of metal shells (Scott Type A). The largest number of these daggers and sheaths come from the fortress of Dangstetten, therefore we suggest they be called after this site.

The described daggers and sheaths come from sites and contexts that indicate a dating from the end of the early or the beginning of the middle Augustan Period to the end of the Augustan Period.

**Keywords:** daggers, sheaths, Augustan Period, rivets, brass, Dangstetten, the River Ljubljana

### INTRODUCTION

Upon analysing the early Principate daggers with a semicircular pommel and their sheaths from the River Ljubljana (Slovenia), it turned out that two of the iron daggers and a sheath associated with one of them, all had brass rivets with heads decorated with a raised edge and a small raised circle in the middle; suspension loops on the sheath were also of brass. This feature distinguishes the discussed daggers and the sheath from the majority of other early Principate daggers with a semicircular pommel and Scott Type A sheaths, which have iron suspension loops and iron rivets with decorative enamelled heads.

### FINDS FROM THE RIVER LJUBLJANICA: DESCRIPTION AND CLASSIFICATION

The dagger and its sheath, found in the Ljubljana at Verd (*figs. 1, 2, 15: 6*),<sup>1</sup> are corroded together. They are made of iron; only the suspension loops and ornamented rivets are of pure brass.<sup>2</sup> The surviving length of the dagger in the sheath is 232 mm. The sheath is 207 mm long and 70 mm wide.

<sup>1</sup> The National Museum of Slovenia, Inv. No. V 443. The artefacts were conserved by Irma Langus and Sonja Perovšek, National Museum of Slovenia.

<sup>2</sup> The PIXE analysis was made with a tandem accelerator by Žiga Šmit at the Jožef Stefan Institute in Ljubljana. For the term "pure brass" see Istenič 2005, 199.

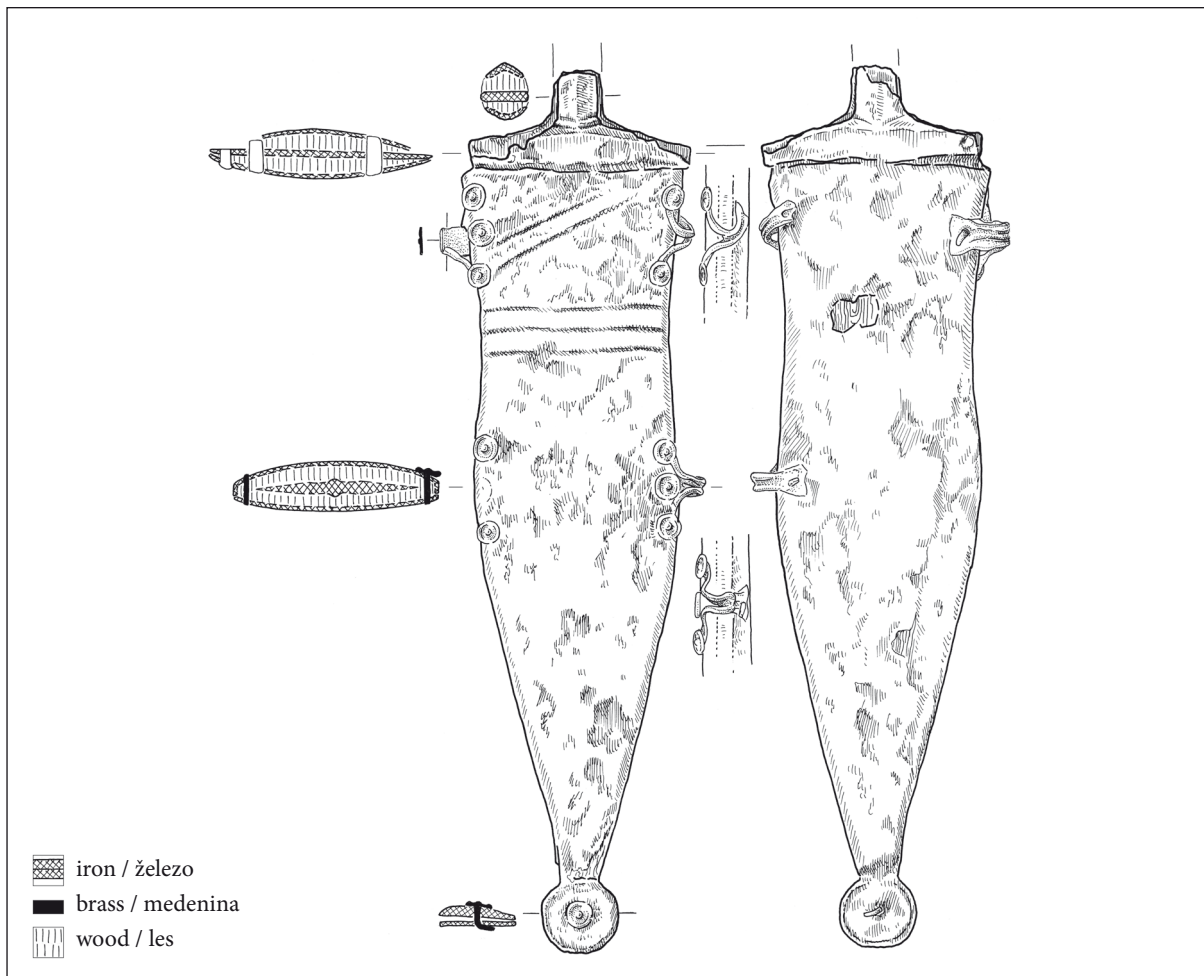

Fig. 1: The dagger and its sheath from the River Ljubljanica near Verd. Scale 1:2 (by and I. Murgelj, NMS and D. Knific Lunder).  
 Sl. 1: Bodalo in nožnica iz reke Ljubljanice pri Verdu. M. = 1:2 (risba: I. Murgelj in D. Knific Lunder).



Fig. 2: The dagger and its sheath from the River Ljubljanica near Verd, both sides (photo: T. Lauko, NMS).  
 Sl. 2: Bodalo in nožnica iz reke Ljubljanice pri Verdu, sprednja in hrbtna stran (foto: T. Lauko, NMS).

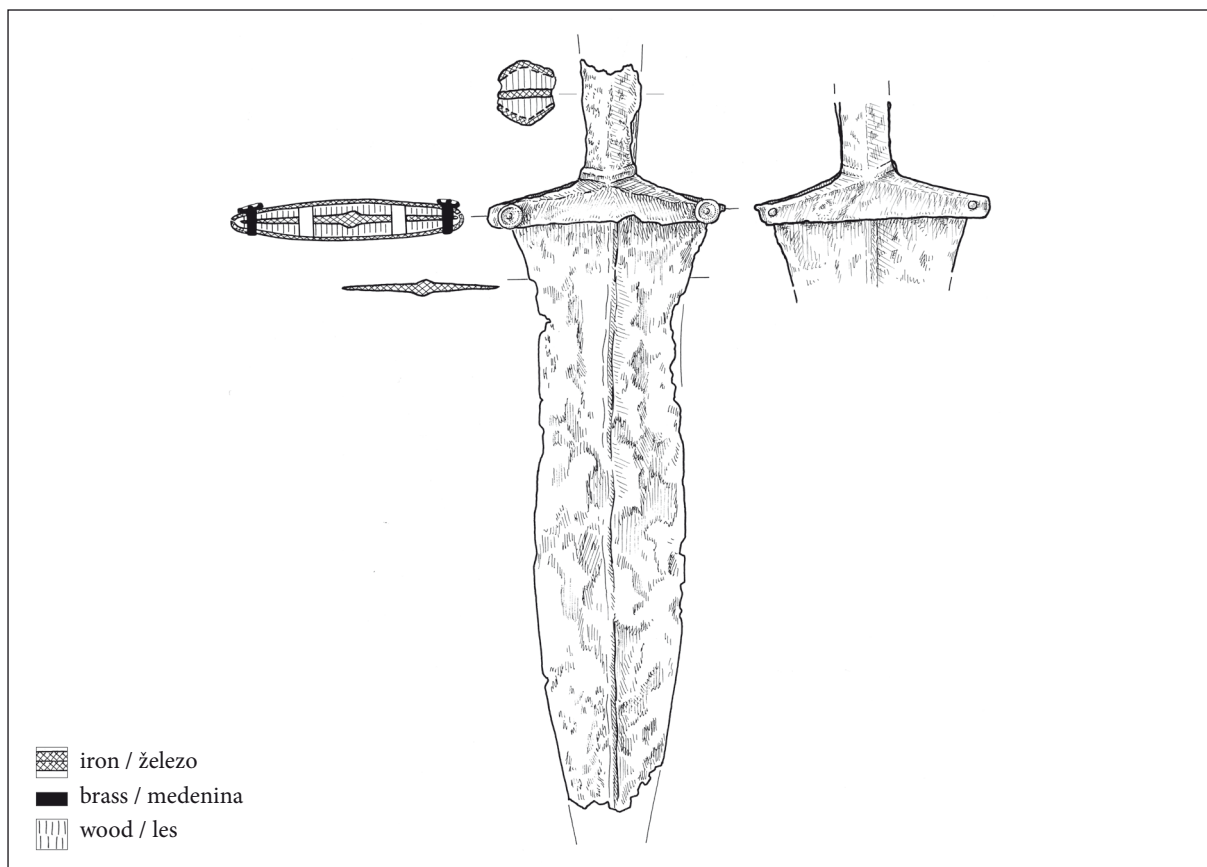

Fig. 3: The dagger from the River Ljubljanica near Podpeč. Scale 1:2 (by D. Knific Lunder).  
 Sl. 3: Bodalo iz reke Ljubljanice pri Podpeči. M. = 1:2 (risba: D. Knific Lunder).



Fig. 4: The dagger from the River Ljubljanica near Podpeč, both sides (photo: T. Lauko, NMS).  
 Sl. 4: Bodalo iz reke Ljubljanice pri Podpeči, sprednja in hrbtna stran (foto: T. Lauko, NMS).

The other dagger, from the Ljubljana at Podpeč (figs. 3, 4; 15: 7),<sup>3</sup> was found without its sheath. Its surviving length is 200 mm and its maximum width is 62 mm. It is also iron, with two decorative rivets made of pure brass. Its blade has a pronounced waist in its upper part and a widened middle part tapering into the tip, which does not survive. The blade has a simple upstanding midrib. The X-ray of the Verd dagger in its sheath (fig. 5) reveals a similar blade with a midrib and a pronounced waist.

In both daggers the blade continues into a tang, which used to be encased in wood, horn or bone, and iron plates as an outer covering. The tang and the plates are attached to one another by rivets. In both daggers, only the lower part of the handle survives. The part enclosing the blade's shoulders contains four rivets. The two rivets at the far end have thin shanks; judging by the well-preserved rivets from the Podpeč dagger, they served mainly as decoration. They are, namely, made of brass, which is golden in colour when there is no patina. Furthermore, the rivets' heads at the front of the dagger have a relief decoration (a raised edge and a circle in the middle). The two middle rivets have no heads, but much thicker shanks and are not visible on the surface; they are clearly discernable on X-rays (figs. 5, 6) and are most probably iron. The preserved parts of the dagger have no other rivets.

The sheath from Verd (figs. 1, 2) consists of two iron shells, attached tightly and invisibly at the sides. The back shell seems straight, whereas the front one is bent more or less at a right angle at both edges. The back reveals wood under the iron shell, which would imply that the inner part of the sheath was made of wood, possibly in thin panels, which protected the dagger's blade (figs. 1, 2).

The two shells are attached to each other by four symmetrically positioned groups of three brass rivets with decorative heads at the edge of the sheath, as well as by a similar rivet positioned in the middle of the circular tip (figs. 1, 2). The same rivets at the sides of the sheath also pin the four suspension loops to the sheath. The decorative rivets' heads closely resemble the brass ones from the handle of the Podpeč dagger (figs. 3, 4).

The surface of the upper front of the sheath contains three horizontal lines with another two parallel diagonal lines above them. They are too poorly preserved to allow an interpretation. It is

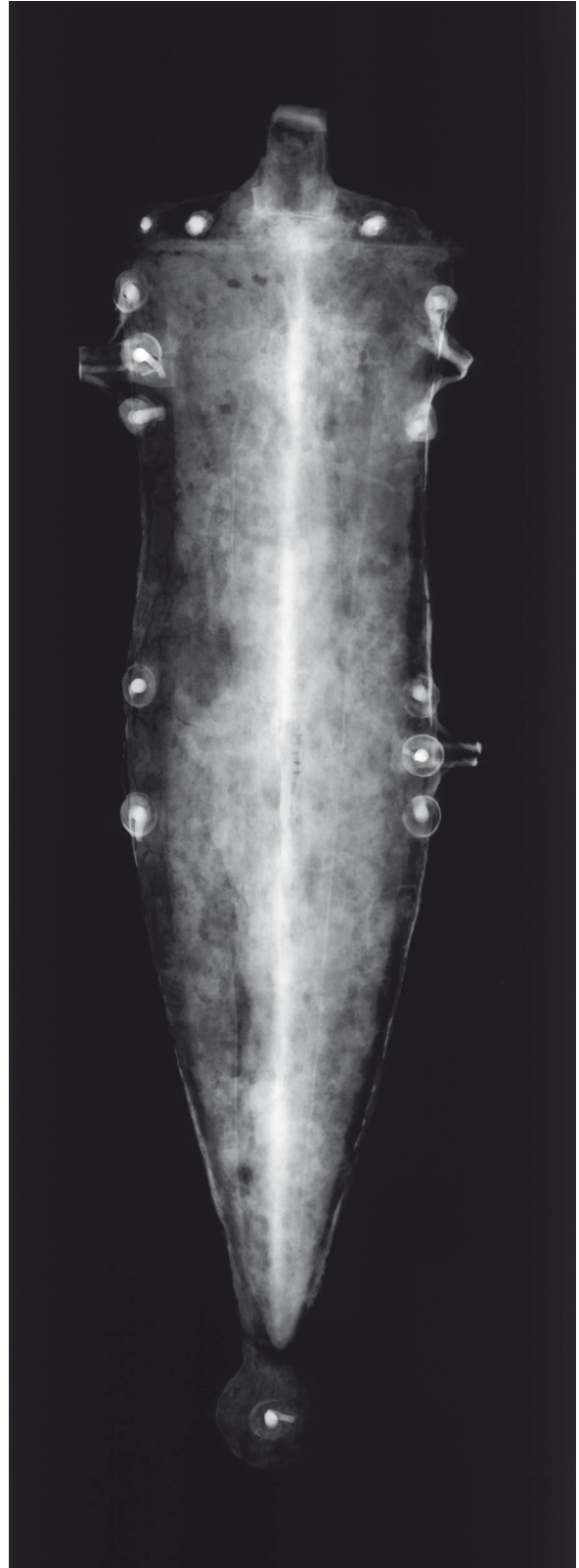

Fig. 5: X-ray radiography image of the part of the dagger in its sheath from the River Ljubljana near Verd. Not to scale (by Z. Milić, NMS).

Sl. 5: Rentgenski posnetek bodala in nožnice iz reke Ljubljane pri Verdu. Ni v merilu (foto: Z. Milić, NMS).

<sup>3</sup> The National Museum of Slovenia, Inv. No. V 2126. The artefacts were conserved by Anita Virag and Sonja Perovšek, National Museum of Slovenia.

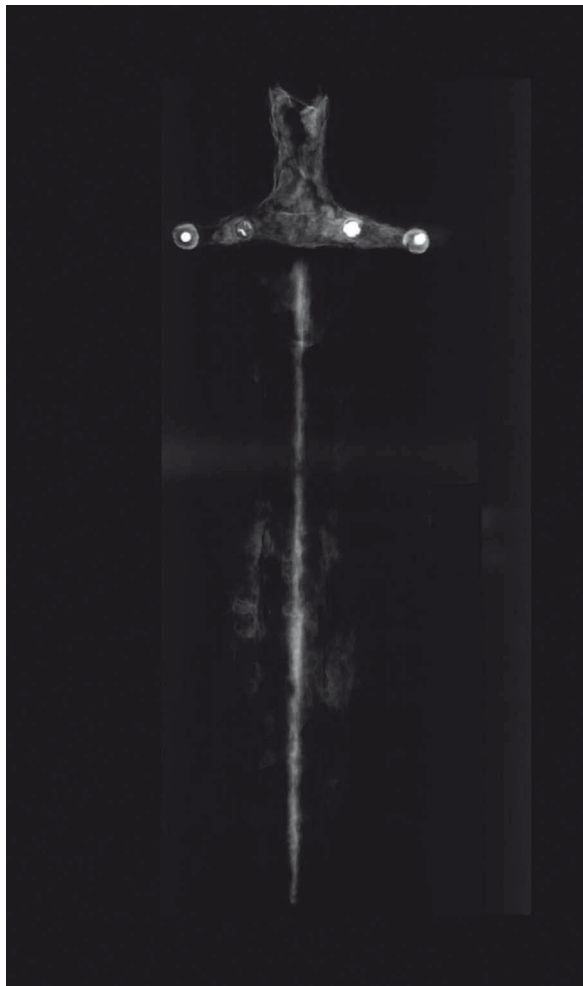

Fig. 6: X-ray radiography image of the dagger from the River Ljubljanica near Podpeč. Not to scale (by Z. Milić, NMS).  
Sl. 6: Rentgenski posnetek bodala iz reke Ljubljanice pri Podpeči. Ni v merilu (foto: Z. Milić, NMS).

not completely out of the question that this was once a (metal-inlaid) decoration (*fig. 1*).

The dagger found at Podpeč and the sheath from the vicinity of Verd share similar rivets (brass, similarly ornamented heads). This would imply that daggers and sheaths with such rivets were designed as a whole and were manufactured in the same workshops. The same goes for other early Roman daggers and associated sheaths.

Both daggers belong to the extensive group of Roman daggers with a flat tang (as opposed to a rod tang) and a handle that was typically constructed by placing rivets through the shoulders and its other parts. Their associated sheaths were made of iron shells (Scott Type A) and lined with wood. They were in use during the Augustan period and

the first half of the 1<sup>st</sup> century AD.<sup>4</sup> The sheath from the vicinity of Verd belongs to this group.

The use of copper alloy for loops and rivets is unusual. Most sheaths with metal shells and their corresponding daggers with a semicircular pommel have iron loops and iron rivets with enamelled heads.<sup>5</sup>

### OTHER DAGGERS AND SHEATHS

A dagger with parts of the sheath (*fig. 7*), which is a close parallel to the described piece from the River Ljubljanica, comes from the Roman fortress of Dangstetten by the Upper Rhine (*fig. 15: 1*),<sup>6</sup> garrisoned from *c.* 20/15 to 9/7 BC.<sup>7</sup> The main similarities include the dagger's blade (the basic form and particularly the simple midrib), as well as the appearance and metal of the ornamented rivets and suspension loops. There were other remnants of "bronze"<sup>8</sup> loops and rivets found at the site (*fig. 8*),<sup>9</sup> which also belonged to similarly decorated sheaths and/or daggers. Another sheath from Dangstetten has "bronze" rivets with similarly shaped decorative heads; however, its suspension loops are different (*fig. 8: 972/5*).<sup>10</sup> The Dangstetten finds include one more parallel to the group in question: it is a sheath with "bronze" rivets with heads, which, judging by the publication, do not have a relief decoration (*fig. 8: 1143/5*).<sup>11</sup>

<sup>4</sup> Scott 1985, 160–167. For the wooden lining of the sheath with metal shells from the Ljubljanica (National Museum of Slovenia, Inv. No. 417) cf. Rant et al. 1994.

<sup>5</sup> Milošević 2003, cover; Niemeyer 1990; Radman-Livaja 2004, figs. 8, 9; Wamser, Flügel, Ziehaus 2000, 321, 330, 331, Cat. No. 22a, 38a. Due to poor descriptions it is often impossible to figure out the material of the rivets and loops. The claim in Bishop, Coulston 2006, 85, that the loops were made of copper alloy is incorrect. Also incorrect is the reconstruction of the sheath from the Kupa at Sisak with its brass loops in Obmann 2000 (pl. 72); the loops and the corresponding rivets are namely of iron (cf. Radman-Livaja 2004, 52, 128, fig. 9, Cat. No. 60).

<sup>6</sup> Fingerlin 1986, 207/3.

<sup>7</sup> Roth-Rubi 2006, 103; ead. 2002; Ehmig 2010; Martin-Kilcher 2011, 44–5, n. 62.

<sup>8</sup> The publication describes the material as bronze, although no analysis was made. The accurate description of the material would therefore be "copper alloy".

<sup>9</sup> Fingerlin 1986, 164/6, 211/15; id. 1998, 552/6? (the material of the loop is not mentioned; the style of the drawing would suggest copper alloy), 625B/1,2.

<sup>10</sup> Fingerlin 1998, 972/5.

<sup>11</sup> Fingerlin 1998, 1143/5.

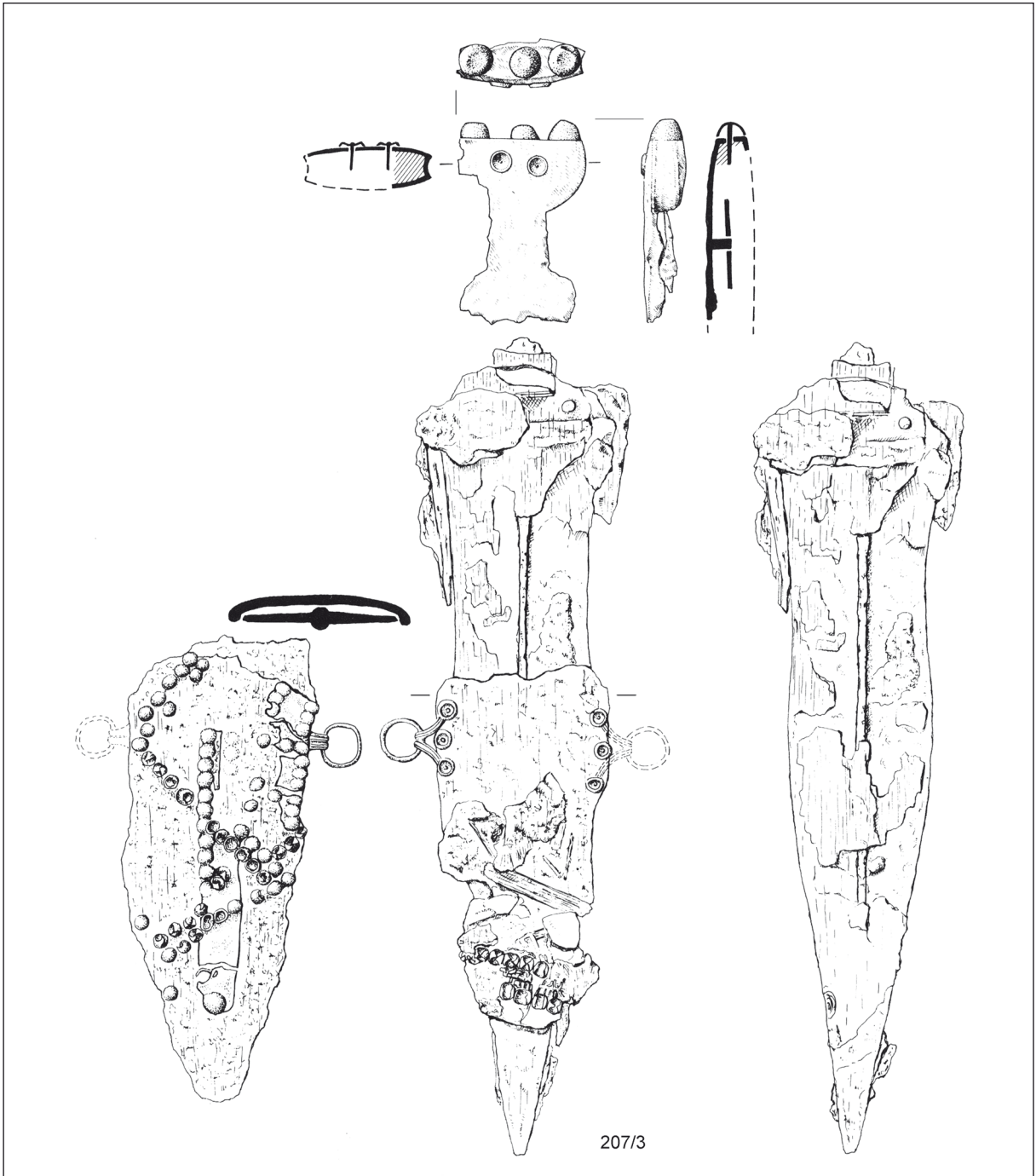

Fig. 7: Dangstetten. The iron dagger and remains of the associated iron sheath with copper-alloy rivets and suspension loops. Scale 1:2 (from Fingerlin 1986, 207/3).

Sl. 7: Dangstetten. Železno bodalo in železna nožnica z okrasnimi zakovicami in zankami iz bakrove zlitine. M. = 1:2 (po Fingerlin 1986, 207/3).

The brass loops and decorated rivets from Dangstetten and the River Ljubljanica sheaths and daggers have excellent analogies among the finds from the middle-Augustan workshop/repair shop at Štalenska gora/Magdalensberg in Carinthia (figs. 9;

15: 5).<sup>12</sup> Very likely, the “bronze” (cf. n. 8.) rivets on a dagger handle and sheath from the middle-

<sup>12</sup> Dolenz, Flügel, Öllerer 1995, figs. 7: 11, 13: 98, 15: 124. The material is described as bronze – cf. n. 8.

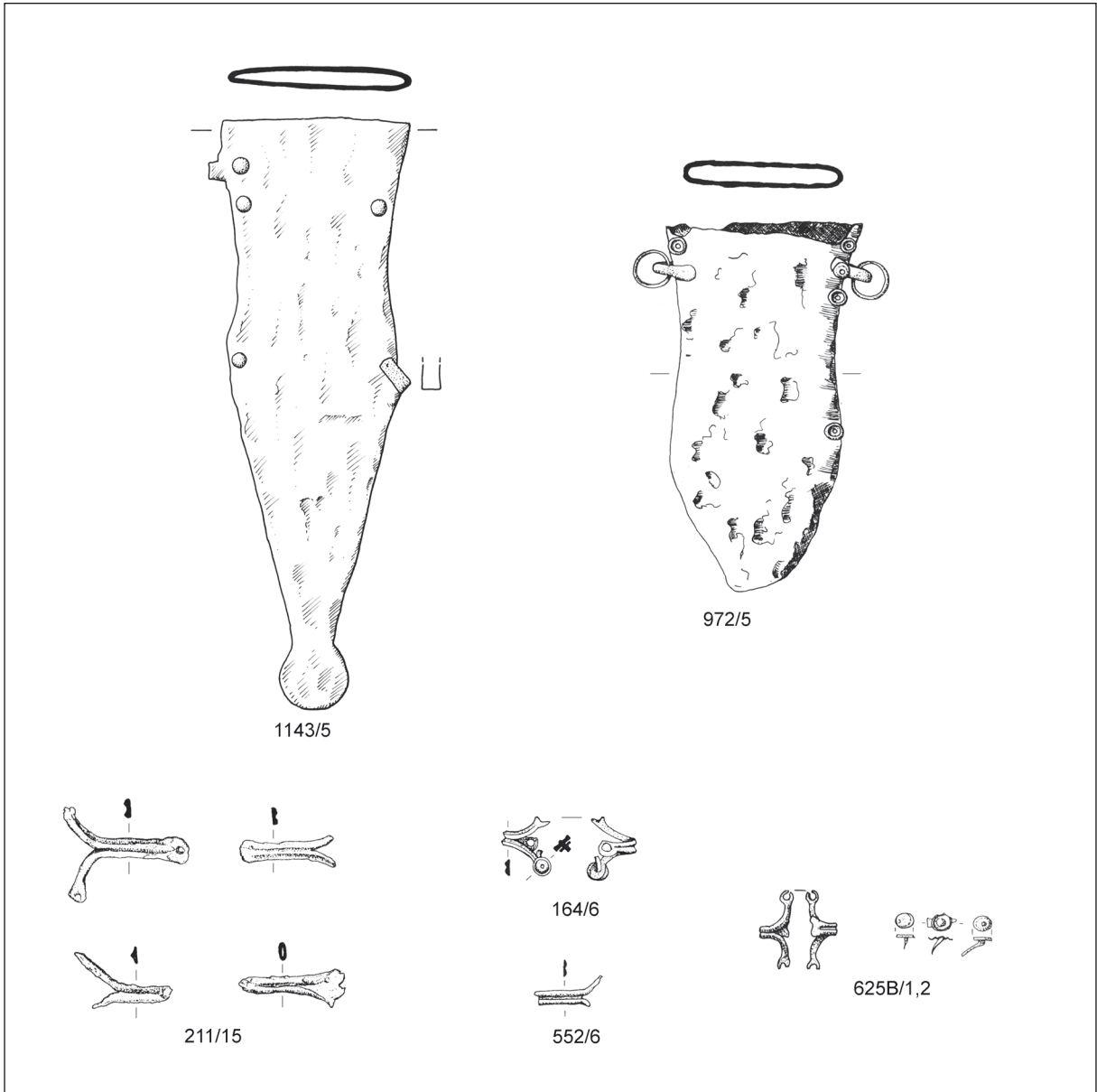

Fig. 8: Dangstetten. Iron dagger sheaths with copper-alloy rivets and suspension loops (from Fingerlin 1998, 1143/5, 1143/5) and fragments of copper-alloy suspension loops and rivets (from Fingerlin 1986, 164/6, 211/15; id.1998, 625B: 1,2). Scale = 1:2.

Sl. 8: Dangstetten. Železni nožnici z okrasnimi zakovicami in zankami iz bakrove zlitine (po Fingerlin 1998, 972/5, 1143/5) ter odlomki (po Fingerlin 1986, 164/6, 211/15; id.1998, 625B: 1,2). M. = 1:2.

In our opinion, it is not probable that the “bronze” rivets with enamelled heads from Magdalensberg are parts of daggers and sheaths (Dolenz, Flügel, Öllerer 1995, 57–58, Cat. Nos. 74–76, 114, figs. 12, 15; Dolenz 1998, 57–58), because such rivets are not known from daggers and their sheaths. The enamelled rivets on daggers and sheaths are namely iron and not copper alloy (Milošević 2003, cover; Niemeyer 1990, figs. 1, 2; Radman-Livaja 2004, figs. 8, 9; Wamser, Flügel, Ziegeus 2000, 318, 321, Cat. No. 18a1–3, 22a).

It is also doubtful that the so-called loops o.c. 70, 74, figs. 12, 15, Cat. Nos. 73 and 113 belonged to the sheaths of the daggers. More or less similarly shaped loops (but with more pronounced and always contiguous volutes; cf. examples in Dolenz, Flügel, Öllerer 1995, 70, Cat. No. 73) belong to Scott Type B sheaths, of which there are so far no known examples prior to the Tiberian Age (Scott 1985, 166; Obmann 2000, 6), whereas the Magdalensberg workshop is middle-Augustan.

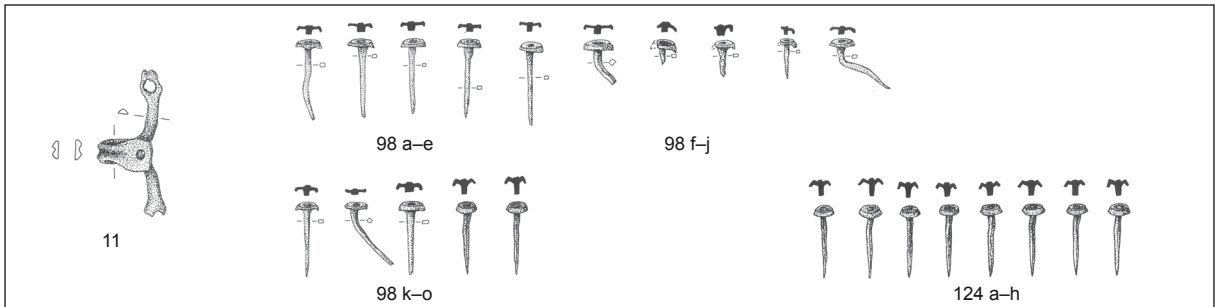

Fig. 9: Magdalensberg. Copper alloy suspension loop (11) and rivets, presumably from daggers or their sheaths (98 and 124). Scale 1:2 (from Dolenz, Flügel, Öllerer 1995, figs. 7: 11, 13: 98; 15: 124).

Sl. 9: Štalenska gora/Magdalensberg. Zanka nožnice bodala (11) in okrasne zakovice, domnevno deli bodal in/ali njihovih nožnic (98 in 124). Vse bakrova zlitina. M. = 1:2 (po Dolenz, Flügel, Öllerer 1995, sl. 7: 11, 13: 98, 15: 124).

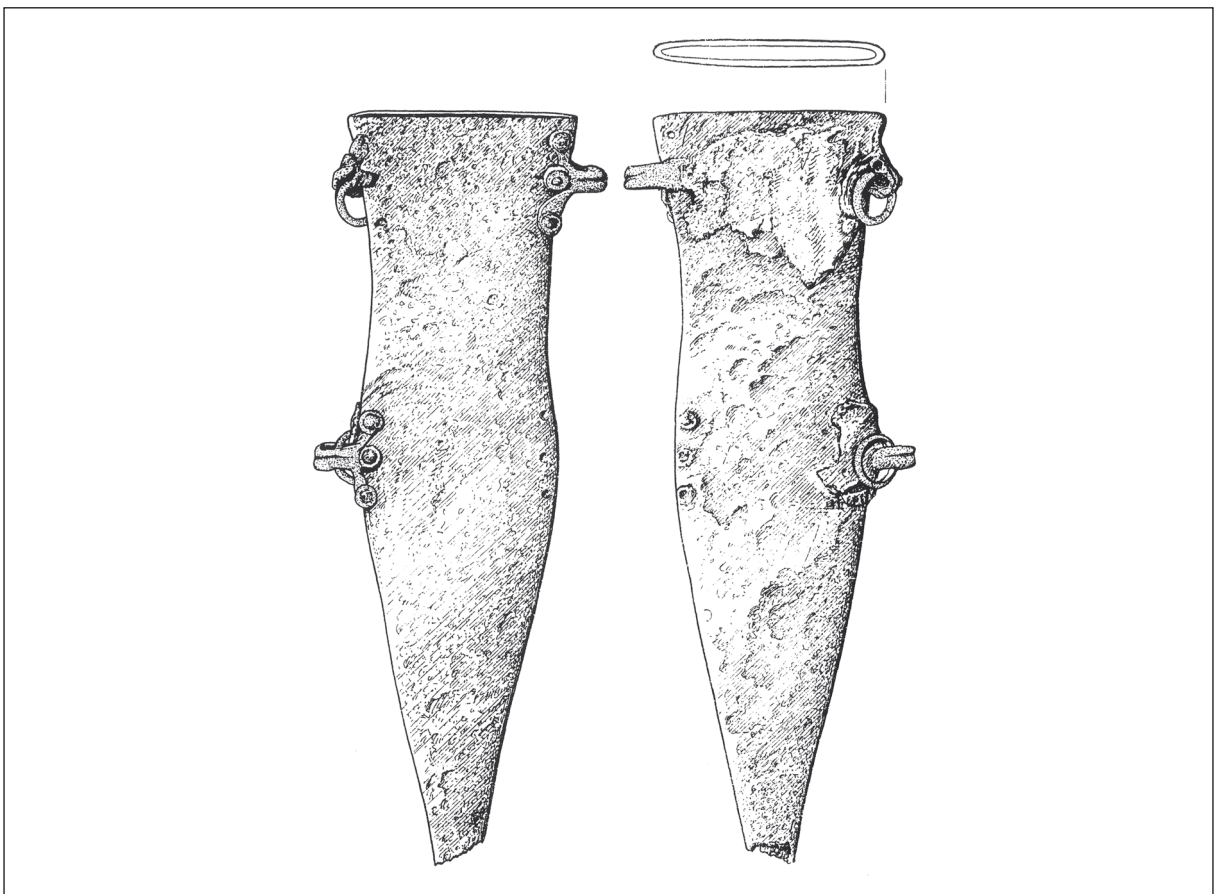

Fig. 10: Anreppen. Iron dagger sheath with copper alloy suspension loops and rivets. Scale 1:2 (from Obmann 2000, pl. 26).

Sl. 10: Anreppen. Železna nožnica bodala z zankami in zakovicami iz bakrove zlitine. M. = 1:2 (po Obmann 2000, t. 26).

Augustan (11–8/7 BC)<sup>13</sup> fortress at Oberaden by the River Lippe (fig. 15: 3)<sup>14</sup> were also similarly shaped. Additional conservation and a detailed

scrutiny of daggers and sheaths from this site<sup>15</sup> might uncover other examples with brass rivets and loops. At least one dagger, however, had iron

<sup>13</sup> Kühlborn 1992, 123, 133.

<sup>14</sup> Albrecht 1942, 160, pl. 52: 9 (it is not clear from the publication, which contains a black and white photograph

rather than a drawing, whether the rivets' heads are preserved and in what manner they are shaped).

<sup>15</sup> Albrecht 1942, 160, pl. 52: 1–3, 5.



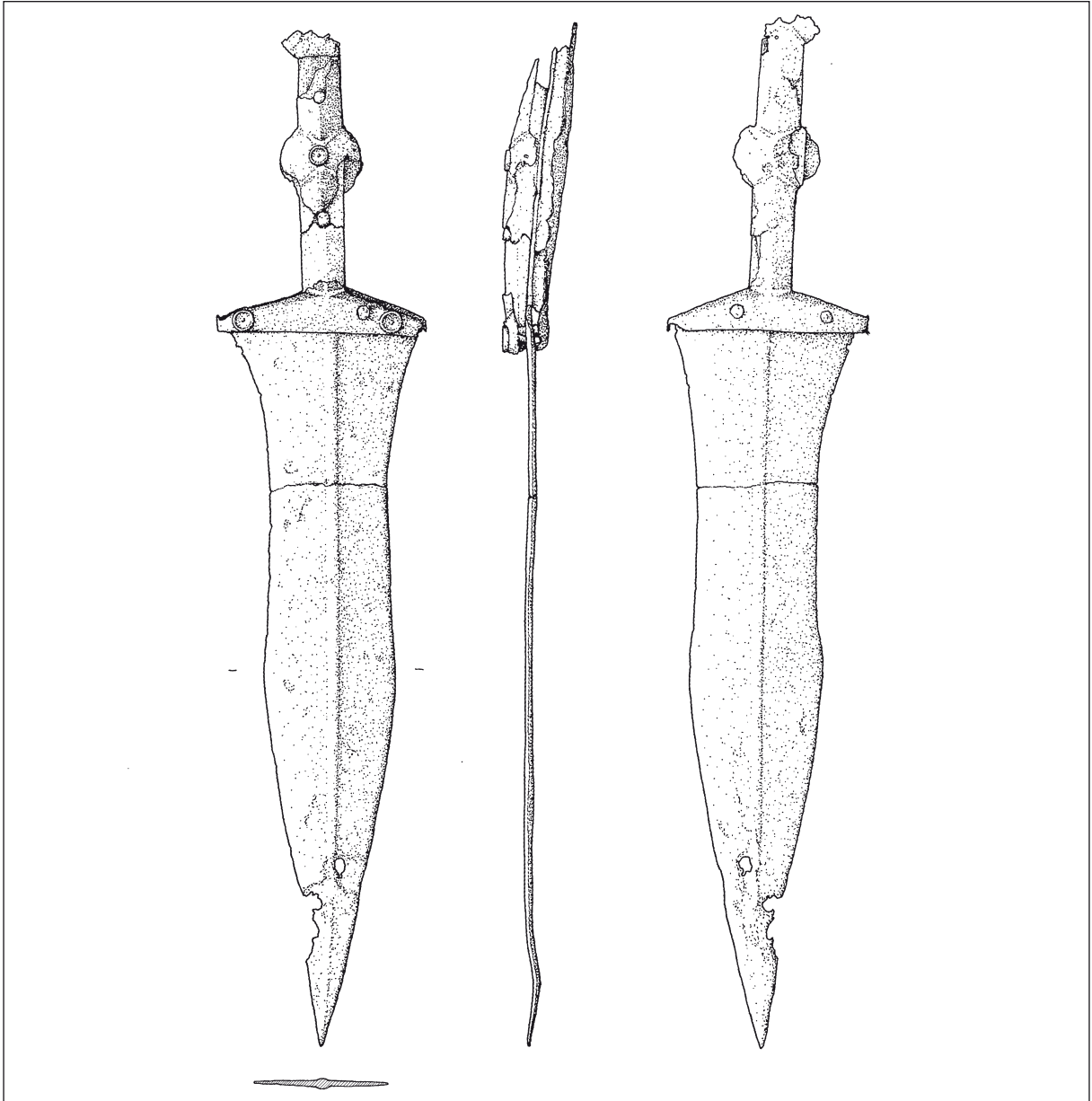

Fig. 12: The River Kupa at Sisak. The dagger with copper alloy rivets. Scale 1:2 (from Radman-Livaja 2004, pl. 14: 57).  
Sl. 12: Reka Kolpa pri Sisku. Bodalo z okrasnimi zakovicami iz bakrove zlitine. M. = 1:2 (po Radman-Livaja 2004, t. 14: 57).

rivets, according to the sketchy descriptions in the publication.<sup>16</sup>

Somewhat younger is a sheath with copper-alloyed loops and rivets with relief decorated heads (a raised edge and circle in the middle) from the fortress of Anreppen by the River Lippe (figs. 10; 15: 4),<sup>17</sup> which was garrisoned from AD 4 to 6 or 9 at the latest.<sup>18</sup>

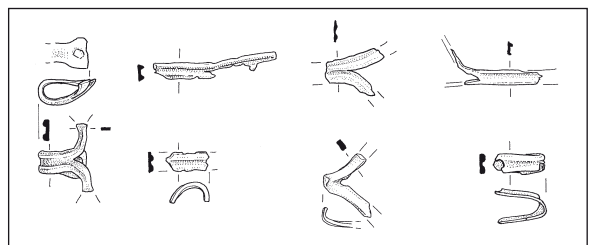

Fig. 11: Ljubljana – Gornji trg. Fragments of copper alloy suspension loops from dagger sheaths. Scale 1:2 (from Vičič 2002, pl. 12: 48–54).

Sl. 11: Ljubljana – Gornji trg. Odlomki zank nožnic bodal, bakrova zlitina. M. = 1:2 (po Vičič 2002, t. 12: 48–54).

<sup>16</sup> Albrecht 1942, 160, pl. 52: 4.

<sup>17</sup> Kühlborn 1995, 142, fig. 9; colour photograph: Kühlborn 2009, 14, fig. 13; Obmann 2000, 27, Fundliste 1: 1, pl. 26).

<sup>18</sup> Kühlborn 2009, 32–34; Tremmel 2008, 147–150, 159.

We assume that the fragments of the “bronze”<sup>19</sup> loops coming from the Ljubljana (*figs. 11; 15: 8*) Roman military equipment workshop or repair shop belonged to the same type of sheaths. The workshop/repairshop was active in the last decade BC or the first two or three decades AD.<sup>20</sup> Taking into consideration the dating of Ljubljana military forts on the right bank of the Ljubljanica<sup>21</sup> and the Roman army’s assistance with the building of the walled town of Emona in the late Augustan Age,<sup>22</sup> the dating of the workshop/repair shop to the middle or late Augustan Age seems plausible.

“Bronze”<sup>23</sup> rivets with similarly shaped heads also decorate the handle of a dagger found in the River Kupa at Sisak (*figs. 12; 15: 9*).<sup>24</sup> The dagger’s blade has a simple midrib, which links it to the other daggers from this group (i.e. examples from the Ljubljana and Dangstetten; *figs. 3–5, 7*).

The shape of the rivets’ heads on the sheath from the Rhine at Mainz (*figs. 13; 15: 2*)<sup>25</sup> allows us to assume that they are made of brass and that this sheath, too, belongs to the group in question.

Based on the PIXE analyses of the rivets and loops on the daggers and sheaths from the River Ljubljana, as well as on the analyses of metals of other Roman military equipment items,<sup>26</sup> it is safe to assume that the “bronze” rivets with decorative heads and loops on daggers and sheaths from the group in question are actually made of brass.

## DISCUSSION

Sheaths and daggers – or parts thereof – with ornamented rivets with distinct relief-decorated heads and suspension loops of copper alloy (most likely brass) are most numerous in Dangstetten (*fig. 15: 1*). In addition to the piece from the River Kupa

and the poorly published item from the Rhine, it is at Dangstetten that the most fully preserved example of such a dagger and its sheath (*fig. 7*) was found. Dangstetten also provides a narrow and accurate time span for dating the daggers and sheaths from this group. We therefore suggest that the group be named after this site.

The two daggers from Dangstetten (*fig. 8*) and the Kupa (*fig. 12*) suggest that in terms of the detailed handle structure the daggers of this group do not differ from other daggers with a tang. The handles of these daggers have eight ornamented rivets: two on the edges of the lower part, which encloses the blade’s shoulders, one on the swelling half-way along its length, two on the front of the semicircular pommel, and three (with different heads) on its straight upper edge. The gap between the two iron plates is closed from the side by a strip of non-ferrous metal, usually copper alloy, which was – judging from the piece from the Ljubljana, pure brass.<sup>27</sup> In addition, the parts of the handle were also held together by iron headless rivets (two on the lower part of the handle, attaching the handle parts to the blade’s shoulders, one below and one above the middle swelling), which are invisible or only barely visible on the surface (*figs. 5, 6, 12*).<sup>28</sup> Another common feature of the daggers is the basic shape of the blade with its simple upstanding midrib (*figs. 3, 5, 7, 12*), typical of the blades of the earliest Roman daggers.<sup>29</sup>

In most sheaths from the Dangstetten group, no decoration survives other than the copper alloy loops and rivets (examples from Oberaden; the Rhine at Mainz, *fig. 13*; Anreppen, *fig. 10*). Aside from the piece from the Ljubljana (*figs. 1, 2*), which might have traces of (metal-inlaid?) decoration, the only other possible exception is the iron sheath from Dangstetten (*fig. 7*). Only its lower part survives. The drawings and the description in the publication

<sup>19</sup> Cf. n. 8.

<sup>20</sup> Vičić 2002, 205, pl. 12: 48–54.

<sup>21</sup> Hvalec 2009, 3, 4.

<sup>22</sup> Gaspari 2010, 142.

<sup>23</sup> Cf. n. 8.

<sup>24</sup> Radman-Livaja 2004, 50–51, 128, Cat. No. 57, pl. 14. Radman-Livaja 2010, 184 – the colour photograph suggests the ornamented rivets are made of copper alloy; the author would like to thank Ivan Radman-Livaja, Arheološki muzej u Zagrebu for confirming that the rivets are of copper alloy (e-mail 15<sup>th</sup> February 2012).

<sup>25</sup> Obmann 2000, 27, Fundliste 1: 11, pl. 24: 1. The publication does not state whether the rivets and loops are made of copper alloy or iron.

<sup>26</sup> Šmit et al. 2005.

<sup>27</sup> In the Dangstetten group, this type of a metal strip is preserved only on the pommel of a dagger from Dangstetten (cf. Fingerlin 1986, 78, 207/3). For other daggers with a semicircular pommel, which have a (partly) preserved metal strip at the side of the handle, see e.g. Harneker 1997, 87, Cat. No. 758, pl. 70; Istenič 2009b, Cat. No. 68; Radman-Livaja 2004, Cat. Nos. 59, 60.

<sup>28</sup> For an example of a dagger with a semicircular pommel that does not belong to the Dangstetten group see the dagger from the Ljubljana at Rakova Jelša, (Milič et al. 2009a, fig. 30). Neutron radiography of the dagger shows a wooden headless rivet in the middle of the pommel.

<sup>29</sup> Titelberg; Metzler 1995, 349, fig. 185. Alesia: Sievers 2001a, 155; id. 2001b, 220, pl. 54: 182. Cáceres el Viejo: Ulbert 1984, pl. 25: 195, 197–199. Cf. Scott 1985, 162.



Fig. 13: The River Rhine at Mainz. A dagger in its sheath. Scale 1:2 (from Lindenschmit 1900, pl. 11: 1).  
Sl. 13: Bodalo v nožnici iz reke Ren pri Mainzu. M = 1:2 (po Lindenschmit 1900, t. 11: 1).

suggest that parts of the “bronze” sheet with lines of small circles (embossed from the back) covered a large part of the iron sheath’s front – a decoration with no known parallels among Roman sheaths. It is difficult to make out the ornament, because it is corroded to the remnants of a leather strap with metal (copper alloy?) fitments.<sup>30</sup> It does not seem entirely unlikely that the pieces of the “bronze” sheet are actually not part of the sheath but also belonged to the corroded leather strap with fitments.

The find spots or contexts of the daggers and sheaths in question clearly show that they were in use from the end of the early Augustan (or beginning of the middle Augustan) Age at the latest until the end of the late Augustan Age.

The daggers and sheaths from this group belong to the oldest examples of daggers with a semicircular pommel and sheaths with metal shells, one of which is also a sheath from the Basel-Münsterhügel site (Switzerland) or, more precisely, from Pit 7,<sup>31</sup> which is contemporary to the fortress in Dangstetten.<sup>32</sup>

In addition to the discussed daggers and associated sheaths, (parts of) “frame-like” dagger sheaths (i.e. sheaths that had originally been of leather and wood with an open metal binding), which are typologically earlier, were also found at Dangstetten.<sup>33</sup> However, there are no remnants of sheaths with iron loops or of sheaths and daggers with iron rivets with enamelled heads.<sup>34</sup>

In most cases, the publication of the daggers and associated sheaths from Oberaden does not give a description of the rivets. However, in one case – in addition to the already mentioned example with the brass rivets – iron rivets are mentioned, but no enamel.<sup>35</sup> A dagger with a double disc handle and a dagger with a cross-shaped pommel come from the same site.<sup>36</sup> They represent earlier types of daggers, since they are depicted on the *denarii* coined for Marcus Junius Brutus in 43/42 BC.<sup>37</sup>

We can therefore conclude that in Dangstetten as well as in Oberaden, earlier, i.e. late Republican

<sup>30</sup> Fingerlin 1986, 78–79, 207/3. The front and back of the sheath are reversed in the description. The part with the two groups of three decorated rivets’ heads is without a doubt the front.

<sup>31</sup> Berger, Helmig 1991, 18.

<sup>32</sup> Roth-Rubi 2006, 103, 117–118.

<sup>33</sup> Fingerlin 1986, 188/11, 280/5; id. 1998, 1034/2.

<sup>34</sup> According to the description and the drawing, the Fingerlin 1986, 552/8 dagger has simple iron rivets.

<sup>35</sup> Albrecht 1942, 160, pl. 52: 1, 4.

<sup>36</sup> Albrecht 1942, 160, pl. 52: 6, 8.

<sup>37</sup> Istenič 2009a, 339; Mackensen 2001, 352–353, fig. 5: 1.

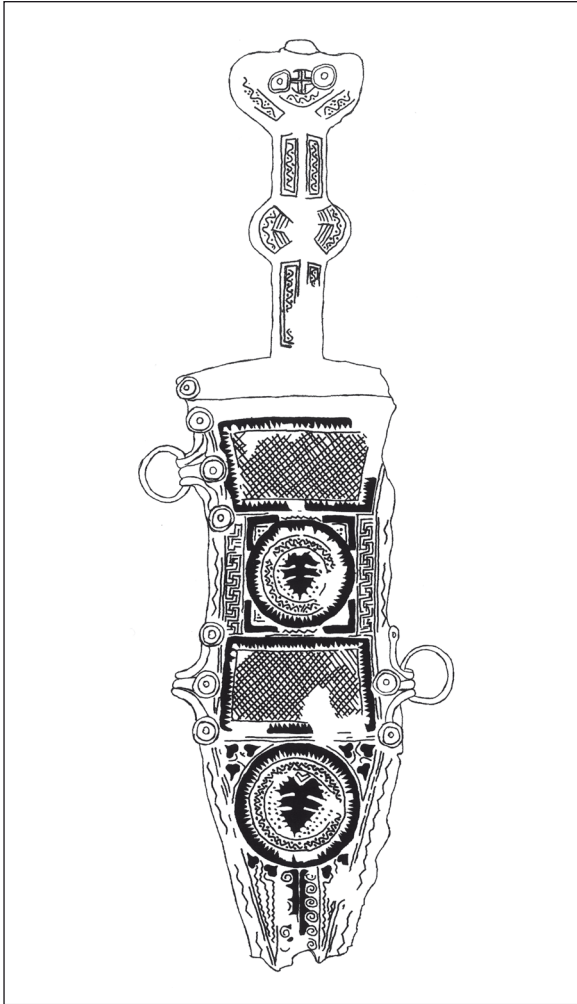

Fig. 14: Döttenbichl near Oberammergau. The dagger in its sheath. Scale 1:2 (from Obmann 2000, pl. 14: D 23).  
Sl. 14: Döttenbichl pri kraju Oberammergau. Bodalo v nožnici. M. = 1:2 (po Obmann 2000, t. 14: D 23).

types of daggers and sheaths were used alongside the ones of the group under discussion. In Oberaden (which chronologically coincides with the late stage of Dangstetten) and possibly in Dangstetten,<sup>38</sup> daggers with a semicircular pommel and iron rivets were also in use. The oldest dated example of a dagger with iron rivets with enamelled heads comes from Haltern,<sup>39</sup> dated between c. 7/0 and AD 9 or perhaps 16.<sup>40</sup> Two sheaths from Dangstetten, belonging to the group in question or close to it, have unusual suspension loops (fig. 8: 972/5, 1143/5),<sup>41</sup> reminiscent of the

asymmetrically positioned loops of the “frame-like” sheath from Titelberg<sup>42</sup> and similar loops of the Celto-Iberian sheaths.<sup>43</sup> They are smaller than other sheaths from the Dangstetten group: while the other sheaths are between 23 and 29 cm long, their presumed length is 12 and 14 cm respectively.<sup>44</sup> Both features imply they are part of the early development of the Dangstetten group, when it was still taking shape.

Related to this group are the famous dagger and associated sheath, found in 1901 south of the Oberammergau settlement in Southern Bavaria (Germany; fig. 14), and another dagger that was much later found close by (fig. 15: 10). Their find spot is situated about 150 metres from the cult site at Döttenbichl, which was in use during the 1<sup>st</sup> century BC and the first half of the 1<sup>st</sup> century AD.<sup>45</sup>

The first dagger from Döttenbichl, signed by its maker Gaius Antonius, and its sheath, both richly decorated with niello and metal inlays, have silver rivets in mint condition with decorative heads shaped as the ones typical of the daggers and sheaths of the Dangstetten group; the suspension loops and rings are also silver.<sup>46</sup> The choice of silver for these parts of the dagger and sheath is another indicator of their links with the Dangstetten group. Brass and silver were namely both precious (brass less so than silver), decorative materials.

The other dagger from Döttenbichl also has rivets with heads typical of the Dangstetten type;<sup>47</sup> the published colour photograph<sup>48</sup> suggests they are silver, but the publication does not state the material of the rivets.

The links between the two daggers and the sheath from Döttenbichl and the Dangstetten group would allow dating them relatively closely, i.e. within the middle to the late Augustan Age.

<sup>42</sup> Metzler 1995, 348–350, figs. 185–186.

<sup>43</sup> Schüle 1969, pl. 37: 2, 166: 1, 2; Cabré 1990, figs. 27, 29; Quesada Sanz 1997, 280, fig. 164: 4.

<sup>44</sup> Sources: Albrecht 1942, 160, pl. 52: 9; Fingerlin 1986, 207/3; Kühlborn 2009, 14, fig. 13; Lindenschmit 1900, pl. 11: 1; Radman-Livaja 2004, 50–51, 128, Cat. No. 57, pl. 14.

<sup>45</sup> Zanier 1994, 97; id. 1997, 47–48.

<sup>46</sup> Ulbert 1962; id. 1971. Colour photograph: Bishop, Coulston 2006, pl. 1.

<sup>47</sup> Zanier 1994, 98, 99, fig. 56.

<sup>48</sup> Zanier 2009.

<sup>38</sup> Fingerlin 1986, 552/8.

<sup>39</sup> Harnecker 1997, 87, Cat. No. 758, pl. 70.

<sup>40</sup> Schnurbein 1991, 69; Wolters 2007.

<sup>41</sup> Fingerlin 1998, 972/5, 1143/5.



Fig. 15: Distribution of daggers and sheaths of the Dangstetten type (a) (1–9) or similar (b) (10). 1 Dangstetten (several examples and their fragments); 2 the River Rhine at Mainz; 3 Oberaden; 4 Anreppen; 5 Magdalensberg (several fragments); 6 the River Ljubljanica near Verd; 7 the River Ljubljanica near Podpeč; 8 Ljubljana (several fragments); 9 the River Kupa at Sisak; 10 Döttenbichl (2 examples).

Sl. 15: Karta najdišč bodal tipa Dangstetten (a) (1–9) in njim sorodnih bodal (b) (10). 1 Dangstetten (več primerkov in odlomki); 2 Ren pri Mainzu; 3 Oberaden; 4 Anreppen; 5 Štalenska gora/Magdalensberg (več odlomkov); 6 Ljubljanica pri Verdu; 7 Ljubljanica pri Podpeči; 8 Ljubljana (odlomki); 9 Kolpa v Sisku; 10 Döttenbichl (2 primerka).

## CONCLUSIONS

The available evidence implies that the daggers and sheaths with ornamented rivets and suspension loops of copper alloy (brass, if judging by the metal analyses of the Ljubljanica items) form a homogeneous group, and we suggest naming it after the Dangstetten (fig. 15: 1) fortress, where the highest number of them was found. They belong to the earliest daggers with semicircular pommel and associated sheaths with metal shells.

Daggers and/or sheaths of the Dangstetten type and their fragments come from nine sites (fig. 15: 1–9), where they derive from 15 contexts. Nine of them (six contexts from Dangstetten and one from Oberaden, Anreppen and Magdalensberg

respectively) allow us to date this type within a relatively narrow time span: the earliest examples come from Dangstetten, the latest from Anreppen, which clearly dates them from the end of the early/beginning of the middle Augustan Age until the late Augustan Age. They are among the earliest daggers with a semicircular pommel and associated sheaths with metal shells Scott Type A. So, the beginning of this type is traced back to the time when the use of late Republican daggers and sheaths was ending and the daggers and sheaths with enamelled rivets and other enamelled ornaments were not yet in production.

It can be concluded that the two daggers and the sheath from the River Ljubljanica were made in the middle or late Augustan Age; this would fit in very

well with our interpretation of the Roman military finds from the River Ljubljanica as an indication of an intense river transport traffic for the purposes of the Roman army during military actions in the wider region, e.g., the Pannonian wars (14–9 BC) and the *Bellum Batonianum* (AD 6–9). Until the end of the Augustan Age, when the road between *Nauportus* and *Emona* (Ljubljana) was built, the traffic across Barje (Ljubljana Marshes) on the River Ljubljanica had been extremely important, because

the Ljubljana was the logical, as well as the most favourable continuation of the main road leading from Northern Italy through *Ocra* (Razdrto) towards the Balkans and the middle Danube area.<sup>49</sup>

Translation: Katarina Jerin

<sup>49</sup> Istenič 2009d, 88–89; ead. 2009f.

- ALBRECHT, Ch. 1942, *Das Römerlager in Oberaden II.* – Veröffentlichungen aus dem Städt. Museum für Vor- und Frühgeschichte Dortmund, Dortmund.
- BERGER, L. and G. HELMIG 1991, Die Erforschung der augusteischen Militärstation auf dem Basler Münsterhügel. – In: B. Trier (ed.), *Die römische Okkupation nördlich der Alpen zur Zeit des Augustus*, Kolloquium Bergkamen 1989, *Bodenaltertümer Westfalens* 26, 7–24, Münster.
- BISHOP, M. C. and J. C. N. COULSTON 2006<sup>2</sup>, *Roman Military Equipment. From the Punic Wars to the fall of Rome.* – Oxford.
- CABRÉ, E. 1990, Espadas y puñales de las necrópolis celtibéricas. – In: F. Burillo Mozota (ed.), *Necrópolis celtibéricas*. II simposio sobre los Celtiberos (Zaragoza 1990), 205–224, Zaragoza.
- DOLENZ, H. 1998, *Eisenfunde aus der Stadt auf dem Magdalensberg.* – *Kärntner Museumsschriften* 75, Klagenfurt.
- DOLENZ, H., Chr. FLÜGEL and Chr. ÖLLERER 1995, *Militaria aus einer Fabrica auf dem Magdalensberg (Kärnten).* – In: *Provinzialrömische Forschungen*. Festschrift für Günter Ulbert zum 65. Geburtstag, 51–80, Espelkamp.
- EHMIG, U. 2010, Zum Vergleich der gestempelten Sigillata aus den römischen Militärlagern von Dangstetten und Oberaden. – *Archäologisches Korrespondenzblatt* 40/4, 551–556.
- FINGERLIN, G. 1986, *Dangstetten I.* – Forschungen und Berichte zur Vor- und Frühgeschichte in Baden-Württemberg 22, Stuttgart.
- FINGERLIN, G. 1998, *Dangstetten II.* – Forschungen und Berichte zur Vor- und Frühgeschichte in Baden-Württemberg 69, Stuttgart.
- GASPARI, A. 2010, “*Apud horridas gentis ...*”. *Začetki rimskega mesta Colonia Iulia Emona / Beginnings of the Roman Town of Colonia Iulia Emona.* – Ljubljana.
- HARNECKER, J. 1997, *Katalog der Eisenfunde von Haltern aus den Grabungen der Jahre 1949–1994.* – *Bodenaltertümer Westfalens* 35, Mainz am Rhein.
- HELMIG, G. 1990, “Hispaniensis Pugiunculus”? – Technologische Aspekte und Anmerkungen zum Fund einer Militärdolchscheide aus Basel. – *Archäologie der Schweiz* 13/4, 158–164.
- HVALEC, S., R. MASARYK, D. BADOVINAC, P. VOJAKOVIČ, J. HRUSTEL, T. ŽERJAL, S. PORENTA, D. ČEŠAREK, S. FIRŠT, I. BEKLJANOV-ZIDANŠEK, A. PLESTENJAK and M. ZOROVIČ 2009, *Utrip Tribune. Doživetja arheološkega vsakdana.* – Ljubljana.
- ISTENIČ, J. 2005, Brooches of the Alesia group in Slovenia / Fibule skupine Alesia v Sloveniji. – *Arheološki vestnik* 56, 187–212.
- ISTENIČ, J. 2009a, An Early Roman dagger from the vicinity of Štanjel. – In: G. Tiefengraber, B. Kavur, A. Gaspari (eds.), *Keltske študije II, Studies in Celtic Archaeology, Papers in honour of Mitja Guštin*, *Protohistoire Européenne* 11, 331–342, Montagnac.
- ISTENIČ, J. 2009b, Roman period. – In: P. Turk, J. Istenič, T. Knific, T. Nabergoj (eds.), *The Ljubljana – a River and its Past*, 265–317, Ljubljana.
- ISTENIČ, J. 2009c, Rimsko obdobje. – V: P. Turk, J. Istenič, T. Knific, T. Nabergoj (ur.), *Ljubljana – kulturna dediščina reke*, 241–293, Ljubljana.
- ISTENIČ, J. 2009d, The Ljubljana and the Roman army. – In: P. Turk, J. Istenič, T. Knific, T. Nabergoj (eds.), *The Ljubljana – a River and its Past*, 86–91, Ljubljana.
- ISTENIČ, J. 2009e, Ljubljana in rimska vojska. – V: P. Turk, J. Istenič, T. Knific, T. Nabergoj (ur.), *Ljubljana – kulturna dediščina reke*, 81–85, Ljubljana.
- ISTENIČ, J. 2009f, The Early Roman military route along the River Ljubljana (Slovenia). – In: A. Morillo, N. Hanel, E. Martín (eds.), *Limes XX, Actas del XX Congreso Internacional de Estudios sobre la Frontiera Romana / Proceedings of the XXth International Congress of Roman Frontier Studies*, *Anejos de Gladius* 13, 855–866, Madrid.
- KÜHLBORN, J.-S. 1992, *Das Römerlager in Oberaden III.* – *Bodenaltümer Westfalens* 27, Münster.
- KÜHLBORN, J.-S. 1995, *Das Römerlager bei Anreppen.* – In: J.-S. Kühlborn (ed.), *Germaniam pacavi – Germanien habe ich befreidet. Archäologische Stätten augusteischer Okkupation*, 130–144, Münster.
- KÜHLBORN, J.-S., BECKER, A. and A. STUPPNER 2008, *Rom auf dem Weg nach Germanien: Geostrategie, Vormarschtrassen und Logistik.* – *Bodenaltertümer Westfalens* 45, 147–168, Mainz.
- KÜHLBORN, J.-S. 2009, *Anreppen, Stadt Delbrück, Kreis Paderborn.* – Münster/Westfalen.
- LINDENSCHMIT, L. 1900, *Altertümer unserer heidnischen Vorzeit* 4. – Mainz.
- MACKENSEN, M. 2001, Ein spätestrepublikanisch-augusteischer Dolch aus Tarent/Kalabrien. – In: *Carinthia Romana und die römische Welt*, Festschrift für Gernot Piccottini zum 60. Geburtstag, 341–354, Klagenfurt.
- MARTIN-KILCHER, S. 2011, Römer und *gentes Alpinae* im Konflikt – archäologische und historische Zeugnisse des

1. Jahrhunderts v. Chr. – In: G. Moosbauer, R. Wiegels (eds.), *Fines imperii – imperium sine fine?*, Osnabrücker Forschungen zu Altertum und Antike-Rezeption 14, 27–62, Rahden/Westf.
- METZLER, J. 1995, *Das treverische Oppidium auf dem Titelberg (G.-H. Luxemburg). Zur Kontinuität zwischen der spätkeltischen und der frühromischen Zeit in Nord-Gallien*. – Dossiers d'archéologie du Musée national d'Histoire et d'Art 3, Luxemburg.
- MILIĆ, Z., G. LEMAJIĆ, S. PEROVŠEK and J. ISTENIČ 2009a, The conservation and restoration of finds from Ljubljana. – In: P. Turk, J. Istenič, T. Knific, T. Nabergoj (eds.), *The Ljubljana – a River and its Past*, 32–37, Ljubljana.
- MILIĆ, Z., G. LEMAJIĆ, S. PEROVŠEK in J. ISTENIČ 2009b, Konserviranje in restavriranje najdb iz Ljubljane. – V: P. Turk, J. Istenič, T. Knific, T. Nabergoj (ur.), *Ljubljana – kulturna dediščina reke*, 30–35, Ljubljana.
- MILOŠEVIĆ, A. 2003, *Numini Hippi Fluvii*. – Split.
- NIEMEYER, B. 1990, Eine tauschierte und mit Email verzierte Dolchscheide aus Carnuntum. – *Carnuntum Jahrbuch* 1990, 297–301.
- OBMANN, J. 2000, *Studien zu römischen Dolchscheiden des 1. Jahrhunderts n. Chr.* – Kölner Studien zur Archäologie der römischen Provinzen 4, Rahden/Westf.
- QUESADA SANZ, F. 1997, *El armamento ibérico. Estudio tipológico, geográfico, funcional, social y simbólico de las armas en la Cultura ibérica (siglos VI–I a.C.)*. – Monographies instrumentum 3, Montagnac.
- RADMAN-LIVAJA, I. 2004, *Militaria Sisciensia. Nalazi rimske vojne opreme iz Siska u fundusu Arheološkoga muzeja u Zagrebu / Finds of the Roman military equipment in Sisak in the holdings of the Archaeological museum in Zagreb*. – Musei Archaeologici Zagrabienensis Catalogi et Monographiae 1, Zagreb.
- RADMAN-LIVAJA, I. 2010, Siscia kao rimsko vojno oporište / Siscia as a Roman military stronghold. – In: I. Radman-Livaja (ed.), *Nalazi rimske vojne opreme u Hrvatskoj / Finds of the Roman military equipment in Croatia*, 179–212, Zagreb.
- RANT, J., Z. MILIĆ, I. NEMEC, J. ISTENIČ and B. SMODIŠ 1994, Neutron and X-ray radiography in the conservation of the roman dagger and sheath. – In: *4th International conference on non-destructive testing of works of art. Internationale Konferenz Zerstörungsfreie Untersuchungen an Kunst- und Kulturgütern (Berlin, 3.–8. Oktober 1994)*, Deutsche Gesellschaft für Zerstörungsfreie Prüfung e.V. 45/1, 31–40, Berlin.
- ROTH-RUBI, K. 2002, Why Dangstetten? – In: P. Freeman, J. Bennett, Z. Fiema, B. Hoffmann, P. Freeman (eds.), *Proceedings of the XVIIIth International Congress of Roman Frontier Studies held in Amman, Jordan, September 2000*. – BAR. International Series 1084, 509–514, Oxford.
- ROTH-RUBI, K. 2006, *Dangstetten III*. – Forschungen und Berichte zur Vor- und Frühgeschichte in Baden-Württemberg 103, Stuttgart.
- SCHNURBEIN, S. von 1991, Zur Datierung der augusteischen Militärlager. – In: B. Trier (ed.), *Die Römische Okkupation nördlich der Alpen zur Zeit des Augustus*, Kolloquium Bergkamen 1989, 1–5, Münster.
- SCHÜLE, W. 1969, *Die Meseta-Kulturen der Iberischen Halbinsel*. – Madrider Forschungen 3, Berlin.
- SCOTT, I. R. 1985, First century military daggers and the manufacture and supply of weapons for the Roman army. – In: M. C. Bishop (ed.), *Production and distribution of Roman Military Equipment. Proceedings of the Second Roman Military Equipment research Seminar*, BAR. International Series 275, 160–213, Oxford.
- SIEVERS, S. 2001a, Les armes d'Alésia. – In: M. Reddé, S. von Schnurbein (eds.), *Alésia 2. Le matériel*, Mémoires de l'Académie des inscriptions et belles-lettres 22, 121–209, Paris.
- SIEVERS, S. 2001b, Catalogue des armes. – In: M. Reddé, S. von Schnurbein (eds.), *Alésia 2. Le matériel*, Mémoires de l'Académie des inscriptions et belles-lettres 22, 211–292, Paris.
- STARY, P. F. 1994, *Zur eisenzeitlichen Bewaffnung und Kampfesweise auf der Iberischen Halbinsel*. – Madrider Forschungen 18, Berlin, New York.
- ŠMIT, Ž., P. PELICON, J. SIMČIČ and J. ISTENIČ 2005, Metal analysis with PIXE : the case Roman military equipment. – *Nuclear Instruments and Methods in Physics Research, Section B: Beam Interactions with Materials and Atoms* 239, 27–34.
- TREMMEL, B. 2008, Archäologische Indizien für römische Militärlogistik am Beispiel der Funde aus Anreppen. – In: J.-S. Köhlborn et al. 2008, 147–168.
- ULBERT, G. 1962, Der Legionärsdolch vom Oberammergau. – In: J. Werner (ed.), *Aus Bayerns Frühzeit. Friedrich Wagner zum 75. Geburtstag*, 175–185, München.
- ULBERT, G. 1971, GAIVS ANTONIVS der Meister des silbertauschierten Dolches von Oberammergau. – *Bayerische Vorgeschichtsblätter* 36, 44–47.
- ULBERT, G. 1984, *Cáceres el Viejo*. Ein spätrepublikanisches Legionslager in Spanisch-Extremadura. – Madrider Beiträge 11, Mainz am Rhein.
- VIČIČ, B. 2002, Zgodnjerimsko naselje pod Grajskim gričem v Ljubljani. Gornji trg 3 (Frühromische Siedlung unter dem Schloßberg in Ljubljana. Gornji trg 3). – *Arheološki vestnik* 53, 193–221.
- WAMSER, L., C. FLÜGEL and B. ZIEGAUS (eds.) 2000, *Die Römer zwischen Alpen und Nordmeer*, Katalog-Handbuch zur Landesausstellung des Freistaates Bayern in Rosenheim 2000. – Mainz am Rhein.
- WOLTERS, R. 2007, Kalkriese und die Datierung okkupationszeitlicher Militäranlagen. – In: G. A. Lehmann, R. Wiegels (eds.), *Römische Präsenz und Herrschaft der augusteischen Zeit*. Beiträge zu der Tagung des Fachs Alte Geschichte der Universität Osnabrück und der Kommission "Imperium und Barbaricum" der Göttinger Akademie der Wissenschaften in Osnabrück vom 10. bis 12. Juni 2004, 135–160, Göttingen.
- ZANIER, W. 1994, Eine Oberammergauer Passion im Jahre 15 v. Chr.? – *Das Archäologische Jahr Bayern* 1994, 97–100.
- ZANIER, W. 1997, Ein einheimischer Opferplatz mit römischen Waffen der frühesten Okkupation (15–10 v. Chr.) bei Oberammergau. – In: W. Groenmann-van Waateringe et al. (eds.), *Roman Frontier Studies 1995. Proceedings of the 16th International Congress of Roman Frontier Studies*, Oxbow Monograph 91, 47–52, Oxford.
- ZANIER, W. 2009, 3.7.6. Dolch. – In: H. Kenzler et al. (eds.), *2000 Jahre Varusschlacht. Imperium*, 274, Cat. No. 3.7.6, Stuttgart.

## Bodala tipa Dangstetten

### UVOD

Pri obravnavi zgodnjecesarskih bodal s polkrožnim glavičem in njihovih nožnic iz reke Ljubljanice (Slovenija) se je pokazalo, da so dvema železnima bodaloma in nožnici, ki pripada enemu izmed njih, skupne medeninaste okrasne zakovice; zanke za obešanje na nožnici so tudi medeninaste. Po omejenih značilnostih se bodali in nožnica razlikujejo od drugih zgodnjecesarskih bodal s polkrožnim glavičem in njim pripadajočih polnokovinskih nožnic. Večina takih bodal in nožnic ima namreč železne zakovice z glavicami, ki so običajno okrašene z emajlom; prav tako so običajno železne tudi zanke za obešanje na nožnicah.

### PRIMERKA IZ REKE LJUBLJANICE: OPIS IN OPREDELITEV

Bodalo in nožnica, ki sta bila najdena v Ljubljani pri Verdu (*sl. 1, 2, 15: 6*)<sup>1</sup> sta sprijeta. Izdelana sta iz železa, le zanke za obešanje in okrasne zakovice na nožnici so iz čiste medenine.<sup>2</sup> Ohranjena dolžina bodala z nožnico je 232 mm, dolžina nožnice 207 mm in širina nožnice ob ustju je 70 mm.

Drugo bodalo, ki izvira iz Ljubljane pri Podpeči (*sl. 3, 4, 15: 7*),<sup>3</sup> je bilo najdeno brez nožnice. Ohranjeno je v dolžini 200 mm, njegova največja širina pa meri 62 mm. Je železno, le okrasni zakovici sta iz čiste medenine. Njegovo rezilo je močno zožano v zgornjem delu, sledita razširjen srednji del in prehod v konico, ki je odlomljena. Po sredini rezila poteka izrazito rebro. Podobno oblikovano rezilo s sredinskim rebrom in zoženjem v zgornjem delu kaže tudi rentgenski posnetek bodala v nožnici iz okolice Verda (*sl. 5*).

Pri obeh bodalih preide rezilo v držajni jezik, ki je bil prvotno obložen z lesom, rogovino ali kostjo in ima na sprednji in hrbtni strani železno oblogo. Jezik in oblogi držaja spenjajo zakovice. Pri obeh bodalih je ohranjen le spodnji del držaja. V delu, ki objema zgornji del rezila so štiri zakovice. Skrajni stranski zakovici imata tenak trn in sta, kot kažeta dobro ohranjeni zakovici na bodalu iz okolice Podpeči, imeli predvsem okrasno funkcijo. Sta namreč iz medenine, ki se, če na njej ni patine, zlato sveti; poleg tega sta njuni glavici, ki ležita na sprednji strani bodala reliefno okrašeni z dvignjenim robom in bunčico v sredini. Sredinski zakovici sta dosti debelejši in na površini nista vidni, vendar se jasno kažeta na rentgenskih posnetkih (*sl. 5, 6*); zelo verjetno sta železni. Na ohranjenih delih bodal ni drugih zakovic.

Nožnica z Verda (*sl. 1, 2*) je sestavljena iz dveh železnih polovic, ki se tesno in prostemu očesu nevidno stikata ob straneh. Zdi se, da je hrbtna polovica ravna, sprednja pa ob straneh zapognjena. Na hrbtni strani je pod železom jasno viden les, ki kaže, da se je na notranji strani nožnice nahajal les, verjetno v obliki dveh tenkih oblog, ki sta ščitili rezilo bodala (*sl. 1, 2*).

Polovici nožnice sta speti ob straneh s štirimi simetrično postavljenimi skupinami treh medeninnastih zakovic z okrasnimi glavicami, ki so obenem na nožnico pripenjale štiri zanke za obešanje, in z enako zakovico v sredini krožno oblikovanega zaključka (*sl. 1, 2*). Reliefni okras glavic zakovic je enak kot pri glavicah medeninnastih zakovic na držaju bodala iz okolice Podpeči (*sl. 3, 4*).

Na sprednji strani nožnice so v zgornjem delu tri vodoravne linije in nad njimi dve vzporedni diagonalni liniji. Slaba ohranjenost ne omogoča razlage teh sledov. Ni izključeno, da gre za ostanke (tavširanega?) okrasa (*sl. 1*).

Bodalo, ki je bilo najdeno pri Podpeči in nožnico iz okolice Verda povezujejo enake zakovice (medenina, enak reliefni okras glavic), kar kaže, da so bila bodala in nožnice s takimi zakovicami zasnovani kot celote ter da so jih izdelovali v istih delavnicah. To je značilno tudi za druga zgodnjericimska bodala in njihove nožnice.

Obe bodali sodita v široko skupino rimskih bodal z jezičastim (v nasprotju s paličastim) jedrom

<sup>1</sup> Narodni muzej Slovenije, inv. št. V 443. Predmeta sta konservirali Irma Langus in Sonja Perovšek, Narodni muzej Slovenije.

<sup>2</sup> Analize z metodo PIXE je izvedel dr. Žiga Šmit s tandemskim pospeševalnikom na Institutu Jožefa Stefana v Ljubljani. Glede pojma *čista medenina* glej Istenič 2005, 209.

<sup>3</sup> Narodni muzej Slovenije, inv. št. V 2126. Predmet sta konservirali Anita Virag in Sonja Perovšek, Narodni muzej Slovenije.



ročaja in njegovo značilno konstrukcijo, pri kateri držajne zakovice med drugim segajo tudi čez rame rezila. Takim bodalom so pripadale polnokovinske nožnice (tip A po Scottu), ki so bile iz železa in so bile z lesom le podložene. Uporabljali so jih v avgustejski dobi in prvi polovici prvega stoletja.<sup>4</sup> V to skupino nožnic sodi primerek iz okolice Verda.

Uporaba bakrove zlitine za zanke in zakovice odstopa od večine polnokovinskih nožnic in njim pripadajočih bodal s polkrožnim zaključkom držaja, za katere so običajne železne zakovice z emajliranim okrasom in železne zanke.<sup>5</sup>

## DRUGI PRIMERKI BODAL IN NOŽNIC

Iz rimskega legijskega tabora Dangstetten ob zgornjem Renu (*sl.* 15: 1), ki je bil v uporabi med ok. 20/15 in 9/7 pr. Kr.,<sup>6</sup> izvira bodalo z ostanki nožnice (*sl.* 7)<sup>7</sup> in je odlična primerjava opisanim primerkom iz reke Ljubljanice. Odločilne podobnosti se kažejo v rezilu bodala (osnovna oblika in predvsem izrazito podolžno rebro) in okrasnih zakovicah ter zankah za pritrditev (material in oblika okrasnih glavice). K enako okrašenim nožnicam in/ali bodalom so sodili še drugi odlomki "bronastih"<sup>8</sup> zank in zakovic s tega najdišča (*sl.* 8).<sup>9</sup> "Bronaste" zakovice z enako oblikovanimi okrasnimi glavnicami ima še ena nožnica iz Dangstetna, ki pa ima drugačni zanki za pripenjanje (*sl.* 8: 972/5).<sup>10</sup> Obravnavani skupini bodal in nožnic je

<sup>4</sup> Scott 1985, 160–167. O leseni podlogi polnokovinske nožnice iz reke Ljubljanice (Narodni muzej Slovenije, inv. št. 417) prim. Rant et al. 1994.

<sup>5</sup> Milošević 2003, naslovnica; Niemeyer 1990; Radman-Livaja 2004, sl. 8, 9; Wamser, Flügel, Ziegeus 2000, 321, 330, 331, kat. št. 22a, 38a. Iz objav zaradi pomanjkljivih opisov pogosto ni mogoče razbrati, iz česa so izdelane zakovice in zanke.

Trditve v Bishop, Coulston 2006, 85, da so bile te zanke iz bakrove zlitine, je napačna! Prav tako je napačna rekonstrukcija nožnice iz Kolpe pri Sisku, ki prikazuje medeninaste zanke in pripadajoče zakovice iz železa (prim. Radman-Livaja 2004, 52, 128, sl. 9, kat. št. 60).

<sup>6</sup> Roth-Rubi 2006, 103; ead. 2002; Ehmig 2010; Martin-Kilcher 2011, 44–45, op. 62.

<sup>7</sup> Fingerlin 1986, 207/3.

<sup>8</sup> V objavah je material opisan kot bron, čeprav analize niso bile narejene. Korekten opis materiala je torej bakrova zlitina.

<sup>9</sup> Fingerlin 1986, 164/6, 211/15; id. 1998, 552/6? (material zanke ni podan; stil risbe nakazuje, da gre za bakrovo zlitino), 625B/1,2.

<sup>10</sup> Fingerlin 1998, 972/5.

med najdbami iz Dangstetna zelo blizu še nožnica z "bronastimi" zakovicami z glavnicami, ki glede na objavo nimajo reliefnega okrasa (*sl.* 8: 1143/5).<sup>11</sup>

Medeninaste zanke in okrasne zakovice nožnic oziroma bodal iz Dangstetna in reke Ljubljanice imajo odlične primerjave med najdbami iz srednjeavgustejske delavnice ali popravilnice na Štalenski gori (Magdalensberg) na Koroškem (*sl.* 9; 15: 5).<sup>12</sup> Verjetno so bile tako oblikovane tudi "bronaste" (prim. op. 8) zakovice na držaju bodala in na nožnici iz srednjeavgustejskega (11–8/7 pr. Kr.)<sup>13</sup> legijskega tabora v Oberadnu ob reki Lippe (*sl.* 15: 3).<sup>14</sup> Ponovno konserviranje in natančen pregled bodal in nožnic s tega najdišča<sup>15</sup> bi morda pokazal, da so med njimi še drugi primerki z medeninastimi zakovicami in zankami. Iz njihovih skopih opisov v obstoječi objavi pa je razvidno, da je najmanj eno bodalo imelo železne zakovice.<sup>16</sup>

Mlajša je nožnica (*sl.* 10) z zankami in zakovicami, ki imajo značilno okrašene glavice (dvignjen rob in bunčica v sredini) iz bakrove zlitine iz legijskega tabora v Anreppnu ob reki Lippe<sup>17</sup> (*sl.* 15: 4), ki je deloval med letoma 4 in 6 oziroma najkasneje 9 po Kr.<sup>18</sup>

<sup>11</sup> Fingerlin 1998, 1143/5.

<sup>12</sup> Dolenz, Flügel, Öllerer 1995, sl. 7: 11, 13: 98, 15: 124. Material je opisan kot bron – prim. op. 8.

Dvomimo, da k delom bodal oziroma njihovih nožnic s Štalenske gore sodijo "bronaste" zakovice z emajliranimi glavnicami (Dolenz, Flügel, Öllerer 1995, 57–58, kat. št. 74–76, 114, sl. 12, 15; Dolenz 1998, 57–58), saj na bodalih oziroma njihovih nožnicah sicer niso poznane. Pri obojih so namreč z emajlom okrašene zakovice železne, ne pa iz bakrove zlitine (Milošević 2003, naslovnica; Niemeyer 1990, sl. 1, 2; Radman-Livaja 2004, sl. 8, 9; Wamser, Flügel, Ziegeus 2000, 318, 321, kat. št. 18a1–3, 22a). Prav tako dvomimo, da sta k nožnicam bodal sodili domnevni zanki o.c. 70, 74, sl. 12, 15, kat. št. 73 in 113. Nožnice, na katerih se lahko pojavljajo bolj ali manj podobno oblikovane zanke (pri katerih pa se volutna dela vedno stikata in sta izraziteje zavita; prim. primerke navedene v Dolenz, Flügel, Öllerer 1995, 70, kat. št. 73) namreč sodijo k nožnicam tipa B po Scottu, za katere zaenkrat ni podatkov za izdelavo pred tiberijsko dobo (Scott 1985, 166; Obmann 2000, 6).

<sup>13</sup> Kühlborn 1992, 123, 133.

<sup>14</sup> Albrecht 1942, 160, t. 52: 9 (iz objave, ki ne vključuje risbe temveč le črno-belo fotografijo ni razvidno ali so glavice zakovic ohranjene in kako so oblikovane).

<sup>15</sup> Albrecht 1942, 160, t. 52: 1–3,5.

<sup>16</sup> Albrecht 1942, 160, t. 52: 4.

<sup>17</sup> Kühlborn 1995, 142, sl. 9. Barvna fotografija: Kühlborn 2009, 14, sl. 13. Obmann 2000, 27, Fundliste 1: 1, t. 26.

<sup>18</sup> Kühlborn 2009, 32–34; Tremmel 2008, 147–150, 159.

Domnevam, da so odlomki "bronastih"<sup>19</sup> zank (*sl. 11*) iz delavnice ali popravilnice rimske vojaške opreme v Ljubljani (*sl. 15: 8*) pripadali nožnicam iste vrste. Delavnica izvira iz zadnjega desetletja pr. Kr. ali prvih dveh oziroma treh desetletij po Kr.<sup>20</sup> Glede na datacijo vojaških taborov v Ljubljani na desnem bregu Ljubljanice<sup>21</sup> in na sodelovanje rimske vojske pri izgradnji obzidanega mesta Emona v poznoavgustejski dobi<sup>22</sup> se zdi verjetna datacija delavnice/popravilnice v srednjo ali pozno avgustejsko dobo.

"Bronaste"<sup>23</sup> okrasne zakovice z enako oblikovanimi glavicami krasijo tudi držaj bodala, ki je bilo najdeno v Kolpi pri Sisku (*sl. 12; 15: 9*).<sup>24</sup> Rezilo tega bodala ima izrazito osrednje podolžno rebro, kar ga povezuje z drugimi bodali obravnavane skupine (primerki iz reke Ljubljanice in Dangstettna, *sl. 3–5, 7*).

Oblika glavic zakovic na nožnici, ki izvira iz Rena pri Mainzu (*sl. 13; 15: 2*)<sup>25</sup> dovoljuje domnevo, da so iz medenine in da torej tudi ta nožnica sodi v obravnavano skupino.

Glede na analize zakovic in zank na bodalih in nožnicah iz Ljubljanice ter analize materialov drugih predmetov rimske vojaške opreme iz reke Ljubljanice<sup>26</sup> utemeljeno domnevamo, da so navedene "bronaste" zakovice z okrasnimi glavicami in zanke na bodalih/nožnicah obravnavane skupine iz medenine.

## DISKUSIJA

Nožnice in bodala z okrasnimi zakovicami, ki imajo značilno reliefno okrašene glavice in zanke iz bakrove zlitine (najverjetneje medenine) oziroma njihovi deli, so najštevilneje zastopani v Dangstettnu (*sl. 15: 1*). Tam je bil (poleg primerka iz reke Kolpe in slabo objavljenega primerka

iz Rena) najden tudi najbolje ohranjen primerek takega bodala in pripadajoča nožnica (*sl. 7*). Poleg tega je Dangstetten kot časovno ozko in zanesljivo zamejeno najdišče izpovedno za datacijo bodal in nožnic te skupine. Predlagamo torej njihovo poimenovanje po tem najdišču.

Bodali iz Dangstettna (*sl. 8*) in Kolpe (*sl. 12*) nakazujeta, da se bodala obravnavane skupine glede podrobnosti strukture držaja ne razlikujejo od drugih bodal z ročajnim jezikom. Držaji takih bodal imajo osem okrasnih zakovic: dve na robovih spodnjega dela, ki objema vrh rezila, eno na osrednji krožni razširitvi, dve na sprednji strani polkrožnega glaviča in tri (z drugačnimi glavicam kot pri ostalih zakovicah) na njegovem zgornjem ravnem robu. Stranski in vrhnji robovi držaja so bili s strani zaprti (obloženi) s pločevino iz barvne kovine, običajno bakrove zlitine, ki je bila, kot kaže primerek iz reke Ljubljanice, čista medenina.<sup>27</sup> Poleg zakovic so dele držaja spenjali železni zatiči (dva v spodnjem delu držaja, ki objema vrh rezila in dva v paličastem delu), ki na površini niso vidni ali so komajda opazni (*sl. 5, 6, 12*).<sup>28</sup> Bodalom je skupna tudi osnovna oblika rezila z izrazitim podolžnim osrednjim rebrom (*sl. 3, 5, 7, 12*), kakršnega imajo rezila najstarejših rimskih bodal.<sup>29</sup>

Na večini nožnic skupine Dangstetten je ohranjen le okras v podobi zank in zakovic iz bakrove zlitine (primerki iz Oberadna, Rena pri Mainzu [*sl. 13*], Anreppna [*sl. 10*]). Razen primerka iz reke Ljubljanice (*sl. 1, 2*), pri katerem ni jasno, ali ima sledove (tavširanega?) okrasa, je morebitna izjema železna nožnica iz Dangstettna (*sl. 7*). Ohranjen je le njen spodnji del. Glede na risbe in opis v objavi se zdi, da so deli "bronaste" pločevine z linijami iztolčenih bunkic prekrivali velik del sprednje površine železne nožnice, kar nakazuje za nožnice rimskih bodal neobičajen okras, ki mu ne poznamo primerjav.

<sup>19</sup> Prim. op. 8.

<sup>20</sup> Vičič 2002, 196, t. 12: 48–54.

<sup>21</sup> Hvalec 2009, 3, 4.

<sup>22</sup> Gaspari 2010, 142.

<sup>23</sup> Prim. op. 8.

<sup>24</sup> Radman-Livaja 2004, 50–51, 128, kat. št. 57, t. 14. Radman-Livaja 2010, 184 (barvna fotografija, na podlagi katere se da slutiti, da so okrasne zakovice iz bakrove zlitine). Ivan Radman-Livaja je potrdil, da so okrasne zakovice na tem bodalu iz bakrove zlitine (e-mail, 15. 2. 2012).

<sup>25</sup> Obmann 2000, 27, Fundliste 1: 11, t. 24: 1. V objavi ni podatka o tem, ali so zanke in zakovice iz bakrove zlitine ali železa.

<sup>26</sup> Šmit et al. 2005.

<sup>27</sup> Pri bodalih skupine Dangstetten je pločevina na stranskem robu ohranjena le na glaviču bodala iz Dangstettna (prim. Fingerlin 1986, 78, 207/3). Za druga bodala s polkrožnim glavičem z (deloma) ohranjeno pločevino na stranskem robu držaja glej npr. Harneker 1997, 87, kat. št. 758, t. 70; Istenič 2009c, kat. št. 68; Radman-Livaja 2004, kat. št. 59, 60.

<sup>28</sup> Za primer bodala s polkrožnim glavičem, ki ne sodi v skupino Dangstetten, glej bodalo iz reke Ljubljanice pri Rakovi Jelši, inv. št. V 417 (delno objavljeno v Milič et al. 2009b, sl. 30). Nevtronska radiografija ročaja tega bodala je v sredini polkrožnega glaviča pokazala lesen zatič.

<sup>29</sup> Titelberg; Metzler 1995, 349, sl. 185. Alesia: Sievers 2001a, 155; id. 2001b, 220, t. 54: 182. Cáceres el Viejo: Ulbert 1984, t. 25: 195, 197–199. Prim. Scott 1985, 162.

Prepoznavanje okrasa te nožnice je težavno, ker so nanjo prikorodirani ostanki usnjene jermena s kovinskimi (bakrova zlitina?) okovi.<sup>30</sup> Ne zdi se nam nemogoče, da tudi deli "bronaste" pločevine niso del nožnice, temveč da so nekoč pripadali nanjo prikorodiranemu predmetu.

Najdišča oziroma najdiščne okoliščine obravnavanih bodal in nožnic jasno kažejo, da so bila v uporabi od konca zgodnjavgustejske ali najkasneje začetka srednjavgustejske do vključno poznoavgustejske dobe.

Bodala in nožnice obravnavane skupine sodijo med najstarejše primerke bodal s polkrožnim zaključkom držaja in polnokovinskih nožnic, h katerim sodi tudi nožnica z najdišča Basel-Münsterhügel (Švica), natančneje iz jame 7,<sup>31</sup> ki je sočasna taboru v Dangstettnu.<sup>32</sup>

V Dangstettnu so poleg bodal in nožnic obravnavane skupine poznane tudi tipološko starejše okviraste nožnice bodal oz. njihovi deli,<sup>33</sup> ni pa ostankov nožnic z železnimi zankami in nožnic ali bodal z železnimi, z emajlom okrašenimi zakovicami.<sup>34</sup>

Iz objave najdb v Oberadnu pri večini bodal in nožnic ni mogoče razbrati, kakšne so zakovice, vendar so, poleg že omenjenega primerka z medeninastimi zakovicami, v enem primeru navedene železne zakovice, pri katerih pa emajl ni omenjen.<sup>35</sup> Iz istega najdišča izvirata bodali s krožnim oziroma križnim zaključkom držaja.<sup>36</sup> Pripadata tipološko starejšima tipoma bodal, saj sta upodobljena na novcih M. Junija Bruta, ki so bili kovani 43/42 pr. Kr.<sup>37</sup>

Tako v Dangstettnu kot v Oberadnu so torej poleg bodal in nožnic obravnavane skupine uporabljali starejše, iz poznorepublikanske dobe izvirajoče tipe bodal in nožnic. V Oberadnu, ki se časovno ujema z zaključkom delovanja tabora v Dangstettnu, in morda tudi v Dangstettnu<sup>38</sup> so bila poleg tega v uporabi bodala s polkrožnim zaključkom držaja in z železnimi zakovicami. Najstarejši da-

tirani primerki bodala z železnimi zakovicami, ki imajo z emajlom okrašene glavice, je iz taborov v Halternu,<sup>39</sup> ki so datirani med okoli 7/0 do 9 ali morda 16 po Kr.<sup>40</sup>

Dve nožnici iz Dangstettna, ki sodita v obravnavano skupino ali sta ji blizu imata neobičajne zanke za pripenjanje (*sl.* 8: 972/5, 1143/5),<sup>41</sup> ki spominjajo na asimetrično nameščene zanke okviraste nožnice iz Titelberga<sup>42</sup> in na podobne zanke na keltsko-iberskih nožnicah.<sup>43</sup> Sta tudi dosti manjši, kot ostale nožnice te skupine, saj sta njuni celotni dolžini ocenjeni na okoli 12 in 14 cm, dolžina ostalih nožnic pa je okoli 23 do 29 cm.<sup>44</sup> Oboje nakazuje, da sodita na začetek razvoja nožnic skupine Dangstetten, v čas, ko se je skupina še oblikovala.

Z obravnavano skupino bodal in nožnic sta povezana znamenito bodalo in pripadajoča nožnica (*sl.* 14), ki sta bila leta 1901 najdena južno od naselja Oberammergau na jugu Bavarske, in še bodalo, ki je bilo kasneje najdeno v njuni neposredni bližini (*sl.* 15: 10).

Njihovo najdišče je pribl. 150 m oddaljeno od daritvenega mesta na Döttenbichlu, ki so ga uporabljali v prvem stoletju pr. Kr. in v prvi polovici 1. stoletja po Kr.<sup>45</sup>

Na prvem omenjenem bodalu iz Döttenbichla, na katerem je izdelovalec Gaius Antonius ovekovečil svoje ime in na pripadajoči nožnici, ki sta bogato okrašena z nieliranjem in tavširanjem, so odlično ohranjene srebrne zakovice z enako oblikovanimi okrasnimi glavnicami, kot jih poznamo z bodal in nožnic skupine Dangstetten; srebrne so tudi zanke in obročki za pripenjanje na nožnici.<sup>46</sup> Izbira srebra za omenjene dele bodala in nožnice je dodaten pokazatelj sorodnosti s skupino Dangstetten. Medenina in srebro sta bila namreč dragocena (medenina manj kot srebro), okrasu namenjena materiala.

<sup>30</sup> Fingerlin 1986, 78–79, 207/3. Sprednja in hrbtna stran nožnice sta v opisu zamenjani. Sprednja stran je namreč nedvomno tista, na kateri sta ob straneh vidni dve skupini s po tremi okrasnimi glavnicami zakovic.

<sup>31</sup> Berger, Helmig 1991, 18.

<sup>32</sup> Roth-Rubi 2006, 103, 117–118.

<sup>33</sup> Fingerlin 1986, 188/11, 280/5; id. 1998, 1034/2.

<sup>34</sup> Bodalo Fingerlin 1986, 552/8 ima glede na opis in risbo enostavne železne zakovice.

<sup>35</sup> Albrecht 1942, 160, t. 52: 1,4.

<sup>36</sup> Albrecht 1942, 160, t. 52: 6,8.

<sup>37</sup> Istenič 2009a, 339; Mackensen 2001, 352–353, sl. 5: 1.

<sup>38</sup> Fingerlin 1986, 552/8.

<sup>39</sup> Harnecker 1997, 87, kat. št. 758, t. 70.

<sup>40</sup> Schnurbein 1991, 69; Wolters 2007.

<sup>41</sup> Fingerlin 1998, 972/5, 1143/5.

<sup>42</sup> Metzler 1995, 348–350, sl. 185–186.

<sup>43</sup> Schüle 1969, t. 37: 2, 166: 1,2; Cabré 1990, sl. 27, 29; Quesada Sanz 1997, 280, sl. 164: 4.

<sup>44</sup> Viri: Albrecht 1942, 160, t. 52: 9; Fingerlin 1986, 207/3; Kühlborn 2009, 14, sl. 13; Lindenschmit 1900, t. 11: 1; Radman-Livaja 2004, 50–51, 128, kat. št. 57, t. 14.

<sup>45</sup> Zanier 1994, 97; id. 1997, 47–48.

<sup>46</sup> Ulbert 1962; id. 1971. Barvna fotografija: Bishop, Coulston 2006, t. 1.

Drugo bodalo iz bližine Döttenbichla ima zakovice z glavicami, ki so značilne za tip Dangstetten;<sup>47</sup> po barvni fotografiji<sup>48</sup> sklepamo, da so iz srebra. V objavah ni podatka o materialu zakovic.

Ugotovljena sorodnost obeh bodal in nožnice iz Döttenbichla s tipom Dangstetten kaže na datacijo primerkov iz Döttenbichla v srednje- do poznoavgustejsko dobo.

### SKLEP

Razpoložljivi podatki kažejo, da bodala in nožnice z okrasnimi zakovicami in zankami iz bakrove zlitine (tj. medenine, glede na analize primerkov iz Ljubljane) sestavljajo homogeno skupino, za katero predlagamo poimenovanje po legijskem taboru Dangstetten (*sl. 15: 1*). Tam je bilo namreč najdenih največ primerkov takih bodal oziroma nožnic. Sodijo med najstarejša bodala s polkrožnim zaključkom držaja in njim pripadajoče polnokovinske nožnice.

Bodala in/ali nožnice tipa Dangstetten oziroma njihove odlomke poznamo z devetih najdišč (*sl. 15: 1–9*) oziroma 15 razmeroma ozkih kontekstov, od katerih jih devet omogoča razmeroma ozko datacijo (šest kontekstov iz Dangstettena in po eden iz Oberadna, Anreppna in Štalenske gore): najstarejši primerki izvirajo iz Dangstettena, najmlajši pa iz Anreppna, kar jasno kaže na njihovo datacijo od konca zgodnjeavgustejske ali začetka srednjeavgustejske do sredine poznoavgustejske dobe. Sodijo med najstarejša bodala s polkrožnim zaključkom držaja in pripadajoče polnokovinske nožnice. Začetek te skupine torej sodi v čas, ko se je iztekla uporaba poznorepublikanskih bodal in nožnic in ko še niso izdelovali primerkov z emajliranimi zakovicami ter drugim emajliranim okrasom.

Obravnani bodali in nožnica iz Ljubljane so torej iz srednje ali poznoavgustejske dobe, kar se dobro vklaplja v našo že predstavljeno interpretacijo rimskih vojaških najdb iz Ljubljane na Barju, po kateri te odsevajo intenzivne transporte za potrebe rimske vojske v poznorepublikanski in avgustejski dobi, npr. med panonskimi vojnam (14–9 pr. Kr.) in med panonsko-delmatskim uporom (6–9). Promet čez Barje po Ljubljani je bil namreč za rimsko vojsko do izgradnje ceste med Navportom (Vrhniko) in Emono (Ljubljana)

na koncu avgustejske dobe izrednega pomena, saj je bila Ljubljana logično in najugodnejše nadaljevanje glavne poti, ki je vodila iz severne Italije čez Okro (Razdrto) proti Balkanu in srednjemu Podonavju.<sup>49</sup>

Janka Istenič  
Narodni muzej Slovenije  
Prešernova 20  
1000 Ljubljana  
janka.istenic@nms.si

<sup>47</sup> Zanier 1994, 98, 99, sl. 56.

<sup>48</sup> Zanier 2009.

<sup>49</sup> Istenič 2009e, 83; ead. 2009f.