

# The Development of a Hydrostatic Transmission for Self-Launching Gliders\*

Nils Elias THENENT

**Abstract:** In high performance gliders with self-launching capability, belt drives are commonly used to transfer power from the combustion engine to the propeller. For installation flexibility and flight safety reasons it could be advantageous to use a hydrostatic transmission instead. This paper describes the development of such a system at the Aachen University of Applied Sciences. An overview of today's powered gliders is followed by general and detailed considerations of the development process, including the design of a test stand. At the end examples of potential new glider designs are discussed.

**Keywords:** Glider, self-launching capability, hydrostatic transmission

## ■ 1 Introduction

Based on previous work by [Thenent and Dahmann 2011] on the development of a hydrostatic transmission for powered gliders, the present article gives some more insight into alternative propulsion system arrangements and glider lay-outs.

Today's high performance gliders can be equipped with a propulsion system, that allows independent take off, climb and cruise flight, but also ensures that the aerodynamic performance is not degraded during the gliding phase. Most common is a configuration consisting of a combustion engine, installed in the fuselage behind the cockpit, and a propeller mounted on a pylon that extends out of the fuselage. In the powered flight mode the propeller

disc is situated above and behind the cockpit. A belt drive is employed to transfer power from the engine to the propeller.

As there is no clutch to disconnect the engine shaft from the propeller, it is necessary to extend the propeller before starting the engine. The transition phase between the full extension of the propeller and the actual thrust generation puts the glider in an aerodynamically unfavourable configuration. Due to the drag generated by the propeller the sink rate increases by approximately 200% [DG Flugzeugbau GmbH 2005a]. That means, in case the engine does not rev-up, or the power transfer to the propeller breaks, the time available to identify a potential outlanding area is significantly reduced. This condition is further aggravated by the common practise to extend the propeller at an altitude

as low as possible. The regulations for glider Grand Prix stipulate that once the engine is used in flight, the respective glider is considered as if it performed an outlanding [International Gliding Commission 2010]. A decoupling of the engine shaft and the propeller would be desirable, to permit starting the engine without extending the propeller. This would avoid the drag penalty in the case of a drive train failure and might also avoid the loss of points in a competition. The pilot could start-up the engine at a higher altitude to increase the safety margin.

The current propulsion system configuration defines the propeller position by the combustion engine's place of installation. Due to the limited flexibility of the belt drive, the extended propeller needs to be situated in-line with the combustion engine shaft. With the very limited

Dipl.-Ing. (FH) Nils Elias Thenent<sup>1</sup>, M.Eng, Aachen University of Applied Sciences, Faculty of Aerospace Engineering Aachen, Germany

\* A previous version of this article has been published in the proceedings of the Scandinavian International Conference of Fluid Power '11 available under the ISBN 978-952-15-2517-9

<sup>1</sup> Now at the University of Bath, UK; N.E.Thenent@bath.ac.uk

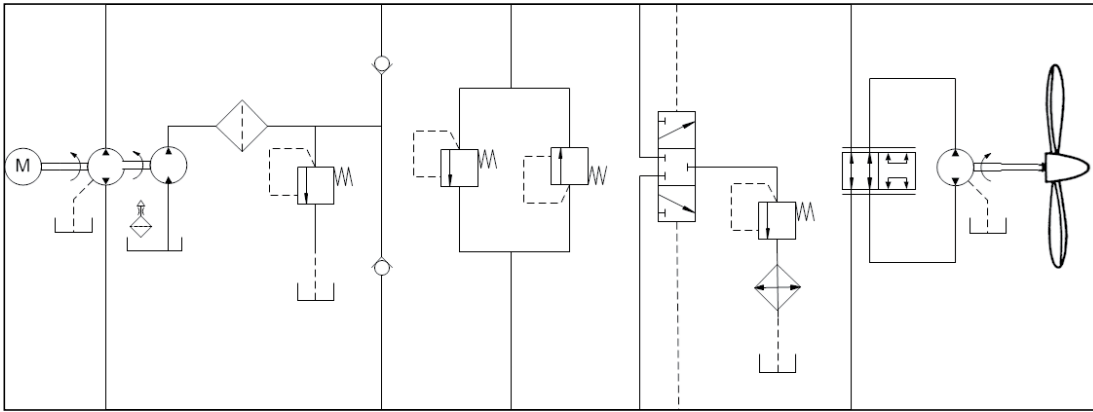

pitch propeller is folded and completely stored in the nose cone. The excellent glide ratio proves the clean aerodynamic shape with the retracted propeller and closed cooling air intakes.

**Figure 1.** Principle layout of a hydrostatic transmission with idle circuit

space available in a high performance glider, the only position to install the engine is behind the cockpit. To ensure a clean aerodynamic shape for gliding, the propeller and the pylon need to be fully enclosed in the fuselage. So the available space in the aft fuselage limits the propeller diameter. For efficiency reasons a large propeller diameter would be desirable [Weinig 1940].

A hydrostatic transmission between the engine and the propeller has the potential to overcome the above mentioned disadvantages of the currently used belt drive transmissions. To decouple the engine from the propeller, a valve controlled idle circuit or a variable displacement pump or motor could be implemented. The flexibility of hydraulic hoses allows an installation of the hydro motor at nearly any position in the airplane. As the required reduction of rotational speed can be implemented by the appropriate displacement ratio between the pump and the motor, the propeller hub can be directly attached to the motor shaft.

## ■ 2 An Overview of Powered Sailplanes

The historical background for motor gliders is leisure flying, which still is the main application. The applicable certification specification is the EASA CS-22 [European Aviation Safety Agency 2003]. Although not reflected in the German aircraft registration regulations, there are two fundamentally different configurations and thus, purposes: high performance and touring motor gliders.

While members of the first category feature many characteristics of single engine propeller planes (Figure 2), the latter are characterized by their main purpose as a glider (Figure 3).

Table 1 shows some properties and performance parameters of typical motor gliders. While the Diamond Dimona, as a touring motor glider, has its engine installed in front of the cockpit, the DG 1000 T and the ASH 25 Mi make use of retractable propulsion systems with the engine installed directly on the extendable pylon or in the fuselage behind the cockpit, respectively.

The Stemme S10 features a unique propulsion configuration and capabilities. Although its engine is located behind the cockpit, the propeller is installed in front of the cabin. The side by side seating arrangement not only provides considerably more installation space, but also allows a shaft running through the cockpit between the two seats. Engine power is transferred from the engine to the propeller via this shaft. During the gliding phase the variable-

Touring gliders are typically used for cross country flying at moderate costs. Compared to a standard single engine aircraft their aspect ratio is high, which leads to a high aerodynamic quality. Therefore they achieve good flight performance even with a relatively small engine. Next to the Diamond Dimona (Figure 2) the Scheibe Falke family is very popular. One of the first touring motor gliders was the Fournier Sportavia RF-3, a single seater with a 29kW engine and a maximum take-off mass of 390kg. Its first flight was in 1963.

## 2.1 High Performance Types

While powered flight is the common mode for a touring glider, the high performance types are mainly operated in the gliding configuration. The energy provided by the engine is only used to assist in case there is no naturally rising air mass in reach, or for gliders with self-launching capability for take-off. As the engines are not designed for long-time operation, and the achievable range is larger, a saw-tooth flight profile is applied for engine assisted long range flights [Sachs et al. 2009, DG

**Table 1.** Motor glider properties and performance

	DG 1001 T [DG Flugzeugbau GmbH 2005b]	ASH 25 EB 28 and [Binder Binder]	Stemme S10 [Jackson 2008]	Super Dimona [Jackson 2008]
Type	Sustainer	Self Launching	Touring	Touring
Seats	2 (tandem)	2 (tandem)	2 (side by side)	2 (side by side)
Max. Power [kW]	22	45	85	85
Max. Take Off Mass [kg]	780	810	850	770
Wing Span [m]	18	28	23	16
Aspect Ratio	19	45	28	17
Max. Glide Ratio	1:45	1:60	1:50	1:27
Max. Climb Rate [m/s]	1,5	2,6	4,2	5,4



**Figure 2.** *Diamond Super Dimona, a popular representative of the touring category. Picture with kind permission of Diamond Aircraft [Diamond Aircraft]*

Flugzeugbau GmbH 2005a]. That means the airplane climbs with a high power-setting to a certain altitude, where the propeller is retracted and the flight is continued in the gliding configuration with a steady loss of altitude. At a minimum altitude the propeller is extended again and the sequence starts from the beginning with the powered climb.

Powered high performance gliders are based on conventional models that are modified to incorporate the propulsion system. Two types of propulsion system are currently the most common: the sustainer and the self-launching. The sustainer is mainly meant to avoid outlandings. Therefore its engine is relatively small and allows typical climb rates around 1,0m/s [DG Flugzeugbau GmbH 2005b]. The airplane has to

of altitude during this manoeuvre is not negligible and can vary between 70m and 140m.

In contrast, the self-launching glider's engine is powerful enough for a take-off without external assistance. The achieved climb rates are in the ballpark of 4m/s [DG Flugzeugbau GmbH 2005a]. A launch with a winch or a tow plane is still possible. Typical engines are two cylinders, two stroke reciprocating or single disc rotary types.

## 2.2 Motor and Propeller Installation

Both sustainer and self-launching types exhibit a similar configuration in the powered flight mode. The propeller is then located above the fuselage with the propeller disc behind the cockpit

be launched like a conventional glider, by means of a tow plane or a winch. To keep the system as simple and light as possible there are solutions without an electrical engine starter. In this case the engine has to be started using the windmilling effect of the propeller. The loss

of altitude during this manoeuvre is not negligible and can vary between 70m and 140m. In contrast, the self-launching glider's engine is powerful enough for a take-off without external assistance. The achieved climb rates are in the ballpark of 4m/s [DG Flugzeugbau GmbH 2005a]. A launch with a winch or a tow plane is still possible. Typical engines are two cylinders, two stroke reciprocating or single disc rotary types.

(Figure 4). As the main focus of the research project is the development of a hydrostatic transmission for a glider with self-launching capability, the motor and propeller installation is exemplarily shown for the propulsion system of the ASK 21 Mi. Like most glid-

ers of this type, its engine is buried in the fuselage behind the cockpit. Particular is however the use of a single rotor wankel engine, which provides a maximum power of 40,4kW at 7750rpm.

The power transfer from the engine shaft to the propeller is realized by a toothed belt. Two tensioner pulleys assure the correct belt tension when the pylon is extended. The propeller has a diameter of 1,55m and is mounted on top of the aerodynamically covered pylon, which folds backwards into the fuselage. For pylon extension an electrical screw jack actuator is used. Engine cooling is assured by an air-liquid heat exchanger, installed downwind of the propeller pylon where it is exposed to the propeller slipstream. To accommodate the propulsion unit in the fuselage the structure is cut open behind the wing attachment and reinforced. This cut-out is closed during gliding by two engine compartment doors. They are opened while the engine is running. To retract the propeller the engine is shut-down and a catch makes certain that the propeller is correctly aligned with the pylon to fit into the engine bay. Then the pylon with the propeller and the engine oil cooler are retracted into the fuselage, and the engine compartment doors are closed.

While the direct mechanical connection between the propeller and the engine does not pose an obvious disadvantage on the ground, it can make an important difference in flight. As the engine can only started with the propeller fully extended, there is a period when the propeller is extended but does not produce any thrust: in fact it incurs significant drag. This leads to an increased sink rate by a factor of the three according to [DG Flugzeugbau GmbH 2005a]. In case the engine cannot be started while the propeller is extended, the probability of an uncontrolled landing is therefore increased. Hence, a mechanical decoupling would be desirable, to provide the pilot with the option to start the engine with the propeller still stored in the fuselage. Once stable engine



**Figure 3.** *ASW 29 high performance motor glider with its propulsion system retracted. Picture with kind permission of Alexander Schleicher GmbH & Co. Flugzeugbau [Alexander Schleicher GmbH & Co]*



**Figure 4.** ASK 21 Mi, glider with self launching capability showing its extended propeller. Picture with kind permission of Alexander Schleicher GmbH & Co. Flugzeugbau [Alexander Schleicher GmbH & Co]

operation is established and the pilot wants to switch to the powered flight mode, the propeller can be extended and as soon as positioned it can be coupled to the engine to generate thrust. The altitude loss can be reduced and the pilot has the option to start the engine before deciding to switch to the powered flight mode. Also, in case the engine does not fire-up, the time to find a suitable outlanding field is increased. Consequently, a hydrostatic power transmission with an idle circuit could increase the safety margin and help to reduce the number of accidents.

Next to the flight safety aspect, an enhanced flexibility in the overall propulsion system layout and therefore aircraft configuration is a good argument for a hydraulic power transfer. The compact shape of a hydraulic motor allows an installation wherever it is considered advantageous. As the cooling can be realized with a central heat exchanger, the motor integration is less problematic than for an electrical motor. According to [Drechsler] a propeller installation in the vertical stabilizer offers great potential. It allows a larger propeller diameter, thus increasing its efficiency. At the same time this location assures sufficient ground clearance without the need for completely re-designed landing gear.

### ■ 3 The Design Process for the Hydrostatic Transmission

Initially the goal is to optimize a closed loop hydrostatic transmission with fixed displacement pump and motor. A glider with self-launching capability seems best suitable to demonstrate the general system

feasibility. The intermittent engine operation suggests that a potential efficiency disadvantage would not be too problematic. An application for a sustainer type by contrast does not seem promising, as this type's main construction principles is simplicity. For a self-launching glider even the likely addition of mass is not necessarily a problem. As it is common practise to load water into the wings to increase the wing loading, minimizing the overall mass is not a main driver. More important is however the mass distribution, considering the limited load carrying capacity of the engine compartment, permissible center of gravity migration and the desire for a maximized water and passenger loading flexibility. Even current propulsion systems can negatively affect longitudinal stability by moving the centre of gravity rearwards. Adding more mass behind the cockpit would further aggravate this tendency.

Two methods shall be used for the preliminary and detailed design in parallel: Numerical simulation and experiments on a test stand. While the test stand is still in the build-up phase, the simulation provided useful understanding of the general system behaviour and gave valuable findings for the design of the test stand.

### 3.1 Design Requirements for a Hydrostatic Transmission

In high performance gliders the fuselage is highly cambered behind the cockpit. Therefore the space available is fairly limited, which already challenges propulsion system installation today. In comparison to a belt drive power transfer, that comprises the two main and two tensioner pulleys, a hydrostatic transmission requires more and, assumingly larger components. There is however space available to accommodate the hydraulic components. The propeller pylon offers installation opportunities for the heat exchanger. The valves should be assembled in a single block to keep the plumbing as short as possible. It is state of the art, that the hydraulic pump is directly mounted with an elastic coupling to the engine. The hydraulic motor should offer the possibility to directly attach the propeller to its shaft, as propellers are dynamically balanced and the aerodynamic forces act mainly in the axial direction. At the moment the installation space does not seem to limit the development of the hydrostatic transfer, but imposes the need for a system as compact as possible.

Starting point is a closed loop hydrostatic transmission with a fixed displacement pump and motor. As the glider manufacturer Alexander Schleicher is one of the project partners, the propulsion system applied in their airplanes sets the main design parameters (Table 2).

While the engine defines the maximum power and the input values to

**Table 2.** Basic performance parameters for the hydraulic transmission conception [Alexander Schleicher GmbH & Co 2007; Austro Engine GmbH 2008; EASA 2009]

$P_{\max}$	40,4kW
$RPM_{\text{in,max}}$	7750
$RPM_{\text{in,cont}}$	7100
$RPM_{\text{out,max}}$	3000

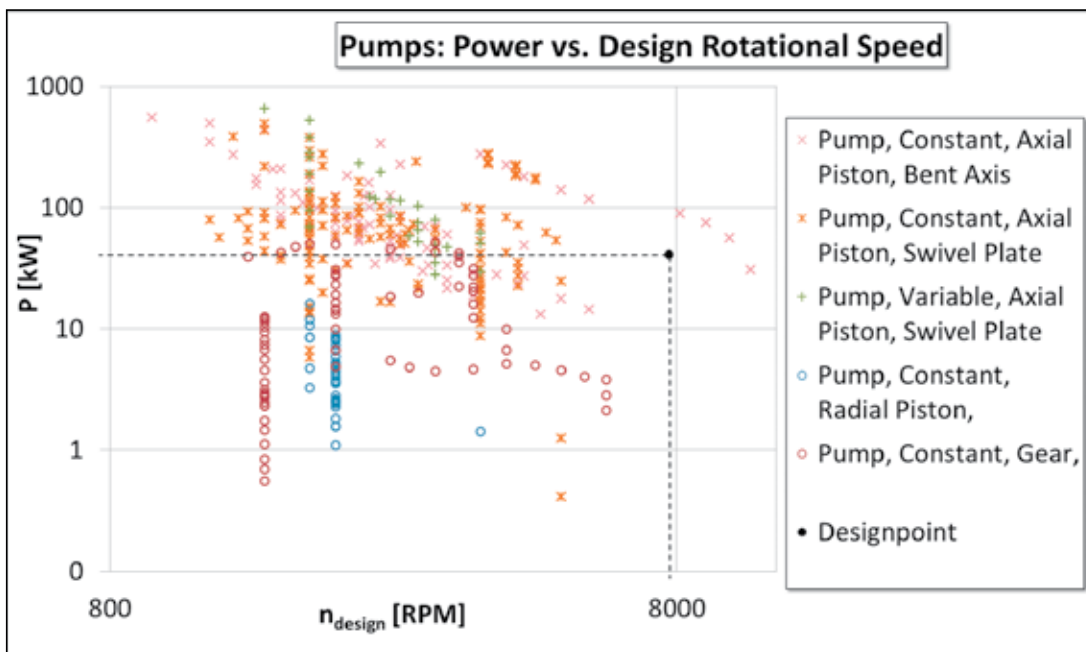

**Figure 5.** A selection of available pumps, as a function of shaft rpm and hydraulic power capability

the transmission, such as maximum and maximum continuous rotational speed, the maximum output RPM is defined by the propeller.

As the availability of a suitable pump and motor is decisive for a potential realization, a market survey was carried out. Figure 5 shows the results for pumps as a comparison of design rotational speed and maximum power. Here, the design point is at 7750RPM and 41kW. Suitable pumps need to be to the right and above that point. It is obvious that only bent axis machines with a constant

displacement offer the required performance.

From the design requirements shown in Table 2 the fluid system parameters can be derived when selecting a suitable pump and motor. The flowrate depends on the pump's rotational speed and displacement. For a given power demand the required system pressure can then be calculated. As there are only certain displacements available, the system parameters cannot be selected freely. Especially the high rotational speed for the pump limits the number of

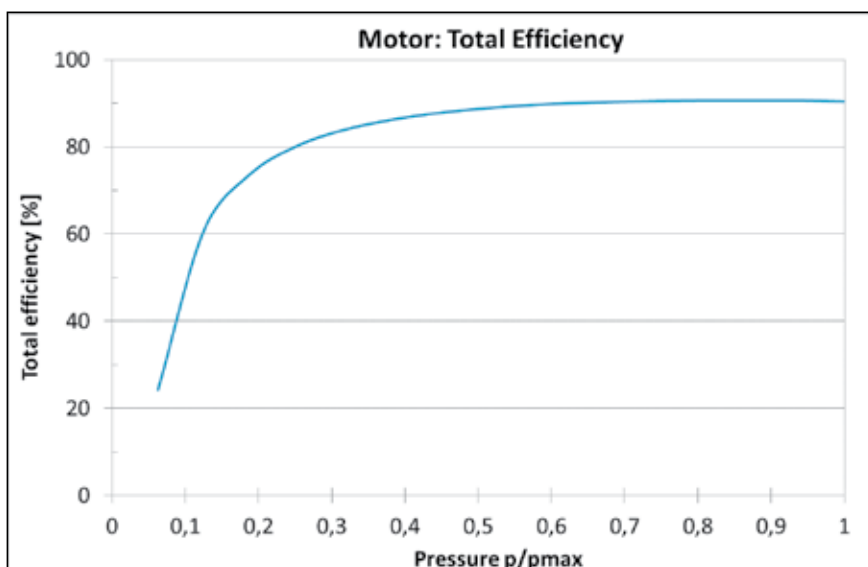
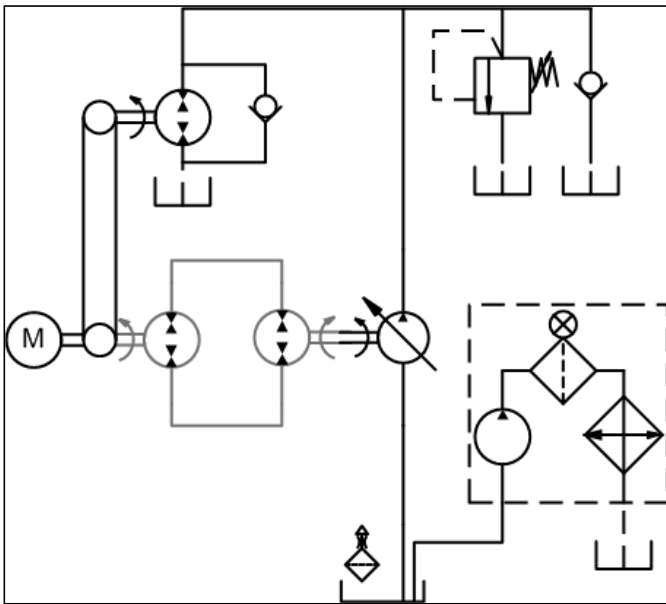

**Figure 6.** Exemplary function of the total efficiency of a motor vs. the relative pressure difference

available alternatives. The currently selected pump has a displacement of 10ccm per revolution. A shaft speed of 7750RPM results in a flowrate of around 75l/min. At a transferred power of 40kW, the pressure increase over the pump lies in the range of 320bar. To assure that the rotational speed of the propeller stays below 3000RPM, a 28ccm bent axis axial piston motor was selected.

For industrial applications a system with a flowrate of 75l/min a reservoir of around would be chosen. But 300l means 240kg of oil – out of the question for a glider. Even mobile applications with closed loop systems require about 0,75min \* flowrate, which still would mean that the reservoir contains more than 55l of fluid. There are however, mobile systems by Honda (Honda HF Lawnmower with hydrostatic drive [Honda Deutschland 2011a] and the motorcycle Honda DN 01 [Honda Deutschland 2011b]) with no external reservoir at all. Especially the DN01 type is worth a closer look, as it covers the same power range as the propeller drive. For the hydrostatic propeller drive the goal is a fluid reservoir volume of 10l.

The operation of powered gliders normally includes 3% powered flight time for take-off and climbing and 97% of gliding with the propeller being retracted. Therefore an expected efficiency disadvantage compared to a belt drive is not a real problem as long as there is enough power for climbing. In fact, due to the particular flight profile, it seems sufficient to maximise the efficiency for maximum continuous power operation. Hence, there is just one design point



**Figure 7.** Test stand schematic with the simplified hydrostatic transmission shown in grey

and the components can be optimised to this point.

Assumingly the two hydro-machines (pump and motor) have the highest impact on the overall system efficiency. *Figure 6* shows how the overall efficiency of the motor depends on the system pressure difference. At about 50% or more of the maximum pressure, the efficiency is around 85 to 90%. Similar values can be expected for the pump. As the rotational speed has a similar influence on the pressure difference, the selection of both components can greatly affect the overall performance of the transmission. The estimate is that a value of 80 to 85% is achievable for the hydrostatic propeller drive.

Apart from the above outlined technical boundary conditions, the system has to fulfil the requirements for powered sailplanes (JAR 22) [European Aviation Safety Agency 2003]. Leakage and the danger of fire are not acceptable and the cooler must be impact-proof.

### 3.2 Limitations and Drawbacks

There are some obvious hurdles that stand against the utilization of a hydrostatic transmission in a self-launching glider. One is certainly the

mass issue. Although, as stated above, one could justify a weight penalty for performance reasons, it still has negative influences on weight and balance considerations. The aim of 25kg for the complete hydrostatic power transfer might be hard to achieve.

Another factor is that while the belt drive is a relatively simple and efficient power transfer, a hydraulic system is a lot more complex and will lead to less available power at the propeller.

At a later stage, if the technical feasibility can be confirmed, certification requirements and costs may still stand against the planned application.

### 3.3 Test Stand

As mentioned above, work on the test stand is still in progress. Nevertheless, its setup and design shall be shown in the following passage. Derived from the general requirements for the hydrostatic transmission, the test stand was designed to provide a 45kW load at given rotational speeds, at the transmission input and output. To keep the consumed energy as low as possible it was decided to use a hydraulic brake that feeds the load back into the system. This way only the losses of the hydraulic systems need to be compensated by the driving electrical motor. The brake features an open circuit layout with a variable displacement pump and a constant displacement motor. An independent cooling and filtering unit is applied to assure thermal and contamination control. The pressure level in the braking circuit can be controlled by a motor driven pressure relieve valve. The de-

sign pressure of the brake is 200bar leading to a flow rate of 135ltr/min at 45kW.

The load for the hydrostatic transmission (simplified in *Figure 7*) is applied by swivelling out the braking circuit's pump. Once the pump provides a flow rate sufficiently large to feed the brake motor, the pressure in the braking circuit builds up and the load is applied. The hydraulic brake power is recuperated by connecting the brake motor via a toothed belt to the input shaft.

To allow a detailed system analysis and, to identify parameters to increase the simulation model quality, a number of sensors are installed in the test stand. Reflecting the importance of the hydrostatic transmission's efficiency, there are torque and rotational speed measuring sensors attached to the pump and motor shaft. Additionally, there are transducers in place to determine hydraulic values, such as flow rates, pressures, fluid temperatures and the fluid level in the reservoir. Especially the flushing, case drain and charging flow rates and pressures are of interest, to determine the origin of power losses in the system.

To monitor the brake circuit the transferred hydraulic power is acquired by the flow rate and the system pressure. Temperature probes in the main line and in the reservoir provide redundancy to verify the function of the cooling circuit. A level sensor is coupled to the temperature probe in the reservoir. All in all there are nearly 30 sensors installed, including ambient temperature and motor and pump surface temperature transducers. The data representation is separated from control functions, to reduce the safety requirements for software programming. A touch screen allows the operator to switch between different visualization modes.

### 3.4 Simulation

To gather a general understanding of a system's behaviour, simulation offers the possibility to visualise sys-

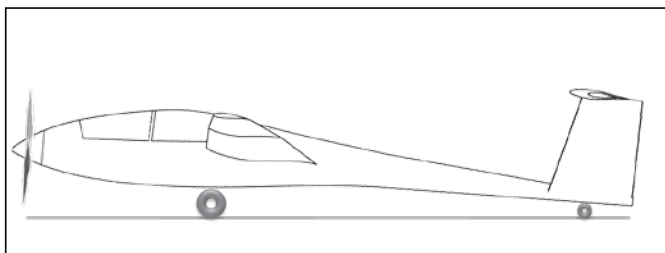

**Figure 8.** Suggested configuration of a tandem seater high performance motor glider with propeller in the nose

tem parameters at any desired point. Furthermore simulation allows the variation of defined system properties and allows a systematic optimization. So far the simulation was primarily used to investigate the general system properties and to select appropriate components, such as valves. Therefore several models using generic parameters were set-up:

- A basic hydrostatic transmission
- A hydrostatic transmission combined with the braking circuit
- A basic thermo-hydraulic circuit

The thermo-hydraulic model gave a first insight into the software's capabilities and gave an idea of the required data for setting up a more advanced model at a later stage.

The basic transmission layout was limited to a one way power transfer, as there was no immediate model for a flushing valve available. The general system properties from the static design were confirmed. Of particular interest for designing the test stand was to confirm the power transfer from the hydrostatic gear to the braking circuit and feedback through the belt drive. Especially the rotational speeds and torques of the pump and motor of the test specimen needed to be verified, to recognize in advance possible overload conditions. With an 80ccm braking pump the load applied can easily exceed the design load of 45kW. Therefore measures have to be taken in the test stand control to prevent an effective swivel plate angle of more than 63%. A very important aspect of the test stand design is the power feedback with the tooth belt drive. A usual test cycle will begin with accelerating the system to a certain rotational speed essentially

without load. In this condition the belt will transfer power to accelerate the freewheeling brake motor. Once the load pump's displacement is increased above a certain volume,

a load is very quickly applied to the hydrostatic gear. As the brake motor is now actually working in the motor mode, it feeds mechanical power through the belt drive to the input. It can be observed, that the direction of power transfer in the belt changes in a short time. This poses a great challenge to the belt drive design. A high power tooth belt was selected to increase the margin of transferable power. A measure to control the load is not only limiting the effective load pump displacement, but also limiting the speed of swiveling out.

#### ■ 4 Potential Glider Configurations

The increased flexibility of positioning the propeller independently from the combustion engine offers opportunities for a variety of unconventional aircraft configurations. Currently it seems that for competition and leisure flying there is no need to significantly change the proven configuration, maybe apart from a propeller installation in the nose.

However, if the desired flight profile differs from the mission of a self-launched high performance glider, the option to relocate the propeller and/or the engine can be advantageous. As the hydraulic transmission easily allows splitting the power, even the application of multiple smaller propellers driven by a single engine can be realized.

There are a number of aspects that need to be considered when selecting the position of the propeller. Among these are for example: propeller efficiency, crash behaviour, dangers to the pilot in case he or

she has to exit the cockpit in flight, noise, influence on the airplane aerodynamic during gliding, required structural reinforcements and consequences on weight and balance affecting longitudinal stability. The following subchapters give some ideas about potential configurations. The outlined characteristics are certainly not comprehensive, but they are meant to give an impression of the repercussions of the propeller installation.

#### 4.1 Propeller in Front of the Cockpit

Considering the propeller installation of today's high performance motor gliders, a nose mounted propeller would offer several, however not only, advantages.

Mounting the propeller in the nose would apply the associated loads directly into the fuselage structure, avoiding their redirection through a propeller pylon. As the thrust vector would be directed through the airplane's center of gravity there would be less, if any, need for trimming the elevator in case of power setting changes.

Looking at the structure behind the cockpit, moveable air inlets could provide sufficient cooling for the engine. Therefore the fuselage cut out, which might still be necessary for engine installation purposes, can be closed by load carrying panels. This would lead to a closed profile again, which has a significantly higher torsional stiffness than an open profile.

*Figure 8* illustrates the need for a high landing gear to assure sufficient ground clearance for the propeller. A single main gear would no longer be suitable to avoid additional wheels with long struts on the wing for balancing. Consequently there would need to be two main landing gear legs, forming a wheel track as large as possible for stability reasons. The latter is particularly important considering the large wing span of high performance gliders.

To incorporate a foldable propeller,

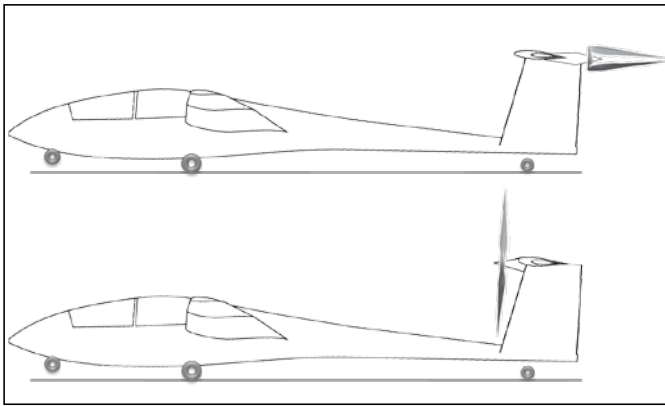

**Figure 9.** Suggested configurations of a tandem seater with propeller installation in the tail

the nose section has to be strengthened and most likely extended. Due to the required modifications to the entire aircraft, it does not seem like an option to equip an existing high performance glider with such a propulsion system. Rather a complete new design or a particular derivate of a current model would be required.

The twin seater Stemme S10 (compare Table 1) is an example of a motor glider with a very high glide ratio and a propeller in the nose. Untypical for touring motor gliders, its engine is installed behind the cockpit. The power transfer to the propeller is realized by a carbon shaft running through a tunnel between the two seats [Stemme AG 2011]. There is also a glider with sustainer engine that makes use of a nose installed propeller. It is the electrically powered LAK 17b FES. In contrast to the S-10, its propeller is not completely covered in a nose cap during gliding, but folds backwards against the fuselage [Remschnig; Znidarsic].

## 4.2 Propeller in the Tail

There are examples of motor gliders with a propeller in the tail. Both positions, in front and aft of the empennage were realized. A vertical tail mounted propeller can be relatively large, as there is no need for a fuselage cut-out and ground clearance can be assured, just by the height of the vertical tail. In case of a propeller in front of the empennage ground clearance is not an issue at all. Installing the propeller in the tail has significant consequences for the tail

structure. The propulsive and reaction forces need to be directed through the fin into the fuselage. Looking at the intersection of the empennage with the rear fuselage tube (Figure 3), current designs feature a weak spot here.

Due to the short distance between the propeller and the lifting and control surfaces of the tail, it seems likely that power setting changes have an effect on the airplane's controllability and stability.

From an aerodynamic point of view, the installation aft of the stabilizer seems better. Here the propeller can be folded out of the free air flow to reduce its drag. The Sunseeker ultralight electric motor glider features a foldable propeller in the tail [Raymond].

At the Institute for Aircraft Construction (IFB) of the University in Stuttgart, Germany [Drechsler] two gliders with a propeller installation shown in Figure 9 were designed, built and flown. The Icaré II is an electrically powered high performance single seater with a 12kW motor and the propeller aft of the tail. Also electrically powered is the e-genius, which can be categorized as a touring motor glider. It features an electric motor on top and in front of the vertical tail.

## 4.3 Twin Prop

As a hydrostatic power transfer allows splitting the available power to two (or more) motors, a configuration featuring multiple propellers could be realized. Smaller propellers

could be utilized, to avoid some of the drawback of the configurations described above.

Like for the configuration shown in Figure 9 bottom, a foldable propeller could be used to lower the drag in the gliding mode.

The AeroVironment Global Observer, a high altitude long range and endurance unmanned air vehicle (UAV), features an internal combustion engine with its power being distributed to four propellers [Putrich 2011]. In this case however, an electric power transfer is employed.

## 5 Outlook

Work on all above mentioned aspects is still in progress. This applies in particular to a more detailed simulation model and the completion and start of operation of the test stand.

To increase the quality of the simulation model several improvements are envisaged. The aim is to use four detailed models, each with characteristic values of the used components, by incorporating appropriate look-up tables. Two of which should be set-up in the normal simulation environment and the other two in the thermal simulation module, one of each reflecting the complete test stand installation, and one applying a combustion engine model and propeller characteristics on the load side.

Test stand operation will start once the build-up is completed. A control strategy to simulate the propeller load as precisely as possible must be developed and implemented. The initial focus of the experiments will be on the identification of power

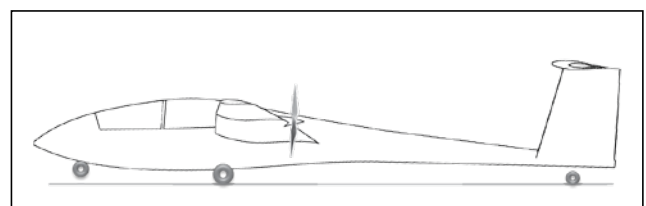

**Figure 10.** Suggested configuration of a tandem seater with two propellers installed in the wing trailing edge



losses and the incremental reduction of the overall oil volume. Also, the possibilities to reduce the heat exchanger size and its aerodynamic drag are of interest.

Once the technical feasibility is demonstrated, certification requirements need to be taken into account more thoroughly. Durability and flight testing of a prototype will need to be prepared in close cooperation with the responsible authorities.

## References

- [1] Alexander Schleicher GMBH & CO. *Alexander Schleicher Homepage*. <http://www.alexander-schleicher.de/>. Accessed 30 November 2010.
- [2] Alexander Schleicher GmbH & Co. 2007. *Flughandbuch für den Motorsegler ASK 21 Mi Baureihe: ASK 21 Mi Kennblatt-Nr. EASA A 221*, Poppenhausen (Wasserkuppe). Austro Engine GmbH. 2008. *IA-E50R-AA Technical Data*, Wiener Neustadt.
- [3] 4 DG Flugzeugbau GmbH. 2005a. *Flughandbuch für den Motorsegler DG-808C. Muster: DG-800A Baureihe: DG-808C*.
- [5] DG Flugzeugbau GmbH. 2005b. *Flughandbuch für den Motorsegler DG-1000T*, Bruchsaal.
- [6] Diamond Aircraft. *HK36 Super Dimona. The Best of Two Worlds*. [http://www.diamond-air.at/bilder\\_multimedia201.html](http://www.diamond-air.at/bilder_multimedia201.html). Accessed 31 March 2011.
- [7] Drechsler, K.D.-I. *Institut für Flugzeugbau (IFB) Home Page*. <http://www.ifb.uni-stuttgart.de/>. Accessed 31 March 2011.
- [8] EASA. 2009. *EASA TYPE-CERTIFICATE DATA SHEET. AS2F1 series propellers*.
- [9] European Aviation Safety Agency. 2003. *Certification Specifications for Sailplanes and Powered Sailplanes. CS-22*.
- [10] Honda Deutschland. 2011a. *Aufsitzmäher. HF 1211*. [http://www.honda.de/garten/gartengerate\\_rasentraktoren\\_aufsitzmaeher\\_auswahl.php](http://www.honda.de/garten/gartengerate_rasentraktoren_aufsitzmaeher_auswahl.php). Accessed 31 August 2011.
- [11] Honda Deutschland. 2011b. *Human Friendly Transmission (HFT)*. [http://www.honda.de/innovation/sicherheit\\_technik/sicherheit\\_human\\_friendly\\_transmission.php](http://www.honda.de/innovation/sicherheit_technik/sicherheit_human_friendly_transmission.php). Accessed 31 August 2011.
- [12] International Gliding Commission. 2010. *Rules for Sailplane Grand Prix*.
- [13] Jackson, P.A., Ed. 2008. *Jane's All the World's Aircraft 2008-2009*. Jane's Information Group.
- [14] Putrich, G. 2011. *Global Observer makes first hydrogen-powered flight*. <http://www.flightglobal.com/articles/2011/01/12/351752/global-observer-makes-first-hydrogen-powered-flight.html>. Accessed 31 March 2011.
- [15] Raymond, E. *Solar Flight Home Page*. <http://www.solar-flight.com/>. Accessed 31 March 2011.
- [16] Remschnig, G. *LAK. Hochleistungssegelflugzeuge*. <http://www.lak17.at/>. Accessed 30 March 2011.
- [17] Sachs, G., Lenz, J., and Holzapfel, F. 2009. *Sägezahnflug-Optimierung zur Maximierung der Reichweite von Motorseglern mit Klapptriebwerk*. Deutscher Luft- & Raumfahrtkongress 2009.
- [18] Stemme AG. 2011. *Stemme Home page*. <http://www.stemme.de/daten/d/index.html>. Accessed 31 March 2011.
- [19] Thenent, N.E., and Dahmann, P. 2011. Hydrostatic Propeller Drive. In *The Twelfth Scandinavian International Conference on Fluid Power. Proceedings of the Conference*, H. SAIRIALA AND K. T. KOSKINEN, Eds., 217–227.
- [20] Weinig, F. 1940. *Aerodynamik der Luftschraube*. Springer, Berlin.
- [21] Znidarsic, L. *FES - Front Electric Sustainer*. <http://www.front-electric-sustainer.com>. Accessed 30 March 2011.

## Razvoj hidrostatičnega pogona za samognana jadralna letala

### Razširjeni povzetek

Prispevek navaja možnost zamenjave klasičnih jermenskih prenosov v samognanih jadralnih letalih s hidrostatičnimi prenosmi. Prednost hidrostatičnih prenosov je v večji fleksibilnosti in varnosti, kar je za letalstvo ključnega pomena. Pri jermensko gnanih propelerjih je velik problem s prostorom za namestitev pogonskega motorja in jermena. Naslednji problem pri uporabi jermenskega prenosa je zagon motorja. Pri jermenskem prenosu se običajno ne uporablja sklopka in propeler se začne vrteti istočasno z motorjem, kar povzroča nevšečnosti pri ogrevanju motorja. Hidrostatični pogon premesti obe opisani težavi. Propeler je lahko direktno pritrjen na hidravlični motor, pogonski motor pa je v tem primeru lahko nameščen kjerkoli na prostem mestu v trupu letala. Povezava med pogonskim motorjem/črpalko in hidravličnim motorjem je izvedena preko gibkih cevi, ki omogočajo popolno lokacijsko neodvisnost hidravlične črpalke od hidravličnega motorja. Prispevek predstavlja delovanje propelerskega pogona štirih različnih, na trgu dostopnih jadralnih letal na konvencionalni jermenski pogon.

Razvojnoraziskovalno delo predstavljenega projekta hidrostatičnega pogona letala je sestavljeno iz numeričnih simulacij delovanja ter dejanskih meritev na preizkuševališču. Dejstvo je, da hidrostatični pogonski sistem propelerja vsebuje več sestavnih elementov kot jermenski prenos. Izhodišče za projektiranje omenjenega hidrostatičnega

pogona je zaprt hidravlični tokokrog s hidravlično črpalko in motorjem s konstantno iztisnino. Posebnost, ki jo je potrebno omeniti, je zelo visoka vrtilna hitrost pogonske gredi črpalke, tj. 7750 vrt./min., in njena zahtevana pogonska moč (41 kW). Tema dvema zahtevama zadosti le aksialno-batna izvedba črpalke z nagibnim bobnom. Enaka konstrukcijska izvedba je bila izbrana tudi za pogonski hidravlični motor propelerja. Naslednja zanimiva posebnost prototipa hidrostatičnega pogona letala je v zelo majhnem rezervoarju, tj. rezervoar z volumnom 10 l. Skupni izkoristek hidrostatičnega pogona letala je med 80 in 85 %. Ta je odvisen predvsem od karakteristike izbrane hidravlične črpalke in motorja. Glede na zahteve evropske letalske varnostne agencije (JAR 22) mora hidrostatični pogon letala zadostiti zahtevam proti puščanju hidravlične kapljevine v povezavi s požarno varnostjo ter zahtevam glede vpliva hladilnika. Pri snovanju pogona je bila ena izmed zahtev, da vse sestavine hidrostatičnega pogona letala ne smejo preseči teže 25 kg. V času pisanja tega prispevka je avtor sestavljal preizkuševališče, tako da rezultatov preizkušanj še ni. Preizkuševališče je zasnovano po principu vračanja energije nazaj v sistem. Elektromotor mora dodati le toliko energije, kot je bilo izgubljene zaradi mehansko-hidravličnih, volumetričnih in ostalih izgub v sistemu.

**Ključne besede:** jadralno letalo, zmogljivost pogona, hidrostatični pogon

### Acknowledgement

The author would like to thank the project partners Alexander Schleicher Flugzeugbau (Poppenhausen, Germany), GL Hydraulics (Aachen, Germany) and the IFAS of the RWTH Aachen (Germany) for their support, and the German Federal Ministry of Education and Research for the project funding.

 **JAKŠA**  
MAGNETNI VENTILI

od 1965

- vrhunska kakovost izdelkov in storitev
- zelo kratki dobavni roki
- strokovno svetovanje pri izbiri
- izdelava po posebnih zahtevah
- širok proizvodni program
- celoten program na internetu



[www.jaksa.si](http://www.jaksa.si)



Jakša d.o.o., Šlandrova 8, 1231 Ljubljana

T (0)1 53 73 066, F (0)1 53 73 067, E info@jaksa.si