

The Periodicity of the Anticipative Discrete Demand-Supply Model

Andrej Škraba¹, Davorin Kofjač¹, Črtomir Rozman²

¹Univerza v Mariboru, Fakulteta za organizacijske vede, Kidričeva cesta 55a, SI-4000 Kranj

²Univerza v Mariboru, Fakulteta za kmetijstvo, Vrbanška 30, SI-2000 Maribor
{andrej.skraba, davorin.kofjac}@fov.uni-mb.si, crt.rozman@uni-mb.si

This paper presents an analysis of the periodicity solutions to the discrete anticipative cobweb model. Dubois' anticipative principle was applied in the modification of Kaldor's cobweb model. Characteristic solutions are gained through the application of a simulation, which determines the cyclical behaviour of supply and demand. Z-transform was applied in the determination of the solutions. The interconnection between the anticipative definition of the cobweb model and Hicks model is addressed.

Keywords: cobweb, hyperincursivity, system dynamics, anticipative system, nonlinear system, Farey tree, chaos

Obrazložitev periodičnosti rešitev anticipativnega diskretnega modela ponudbe in povpraševanja

V prispevku je izvedena analiza periodičnosti v diskretnem anticipativnem cobweb modelu. Pri modifikaciji Kaldorjevega cobweb modela je upoštevan Duboisov anticipativni princip. S pomočjo simulacije so prikazane karakteristične rešitve, ki opredeljujejo ciklična nihanja med ponudbo in povpraševanjem. Pri določitvi rešitev je bila uporabljena z-transformacija. V prispevku je naslovljena povezava med anticipativno definicijo cobweb modela in Hicksovimi modelom.

Ključne besede: cobweb, hiperinkurzivnost, sistemska dinamika, anticipativni sistem, nelinearni sistem, Fareyevno drevo, kaos

1 Introduction

The cobweb model presents the adjustment to market supply and demand. It is typically viewed as the model of the agricultural pricing mechanism. The story behind the model might be briefly explained as follows: "The quantity offered for sale this year depends on what was planted at the start of the growing season, which in turn depends on last year's price. Consumers look at the current prices, though, when deciding to buy. The cobweb model also assumes that the market is perfectly competitive and that supply and demand are both linear schedules." For a clear and extensive introduction to the topic, see Rosser, 2003. The fact, that the cobweb model is in the field of discrete dynamics is rather an advantage, since the systems of difference equations are often easier to grasp. For example, in his enduringly valuable scholarly work on the studies of Dynamic Systems, Luenberger (1979) firstly addresses difference and differential equations later on. The model in question has all the characteristics of classical System Dynamics (SD) models: equilibrium, competitiveness, human perception, delay and adjustment, but somehow it avoids being included settled in the common SD model bank of each SD modeller. The main reason for the elusiveness of the cobweb model lies in its original form, which is not suitable for direct transformation to the common elements such as Level (L) and Rate

(R). The functions of supply $Q_s(k)$ and demand $Q_d(k)$ can be specified in the form:

$$Q_d(k) = a + bP(k) \quad (1)$$

$$Q_s(k) = c + dP(k-1) \quad (2)$$

where a , b , c and d are parameters specific to the individual markets. $P(k)$ and $Q_s(k)$ should be restricted to the positive values. In the cobweb model it is assumed that producers supply a given amount in any one time period (determined by the previous time period's price) and then the price adjusts so that all the products supplied are bought by customers. If we write this in the form of an equation, then $Q_d(k) = Q_s(k)$, which enables us to state that the price is:

$$P(k) = \frac{d}{b}P(k-1) + \frac{c-a}{b} \quad (3)$$

Eqs. 1, 2 and 3 are not quite in the proper form for performing the transformation to the SD model. One of the things is the time argument ($k-1$). The other is the missing Rate (R) elements and the corresponding Δt . One should expect that the transformation will provide the known equations in the familiar form for the structure shown in Fig. 1. The model developed should enable us to examine the prop-

erties of the cobweb model and also to consider its structural and incursive perspective.

As the Wiener's cybernetics principle (Wiener, 1961) stands firm in the system's theory, the cobweb model princi-

ple stands as the basic linearized principle construct for the systems interaction dependence and will probably remain the basic starting tool for the quantitative analysis of complex systems.

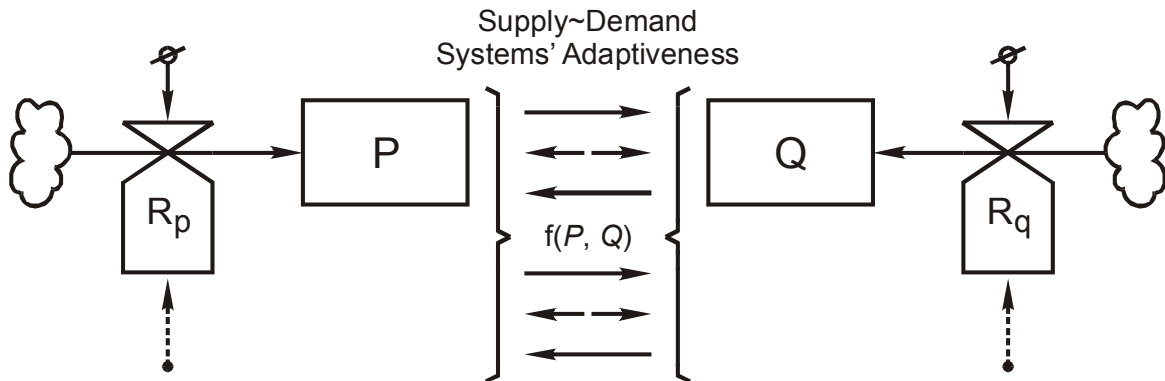

Figure 1. The main elements of the proposed cobweb SD structure

2 Transformation to the SD Form

Fig. 1 shows, that the price P and quantity Q of the goods should be stated as the Level elements depending on the Rates that determine the change in price and quantity supplied. The theory behind the cobweb model states that the quantity supplied at the present depends on the price in the past. Therefore the price and the quantity supplied should be dependant variables as illustrated in Fig. 1. Restating the above Equations, while eliminating the time argument $k-1$, gives us the following set of equations:

$$Q_d(k + 1) = a + bP(k + 1) \tag{4}$$

$$Q_s(k + 1) = c + dP(k) \tag{5}$$

$$P(k + 1) = \frac{d}{b}P(k) + \frac{c-a}{b} \tag{6}$$

Eqs. 4, 5 and 6 will enable the determination of the Rates elements. Let us determine the Rate element for the change of Price $R_p(k)$. As the equations are in the different form the Rate will be determined as $R(k)=L(k+1)-L(k)$:

$$R_P(k) = P(k + 1) - P(k) = \frac{c+dP(k)-Q_s(k)}{b} \tag{7}$$

A little more work will be needed for the $R_Q(k)$ since special time considerations had to be taken. We will apply the time arguments of $k+1$ and $k+2$ in order to loose the $k-1$ argument that is present in Eq. 2:

$$R_Q(k) = Q_s(k + 2) - Q_s(k + 1) = d \frac{c+dP(k^*)-Q_s(k^*)}{b} \tag{8}$$

Since the time k^* argument with the consideration of Eq. 1 and 2 actually represents the past, i.e. the $k-1$ argument, we should state the equations for $P(k-1)$ and $Q_s(k-1)$. Eq. 3 will enable us to state $P(k-1)$:

$$P(k - 1) = \frac{bP(k)-c+a}{d} \tag{9}$$

$$Q_s(k - 1) = a + P(k - 1) b \tag{10}$$

Eq. 10 is set by the fact that $Q_d(k) = Q_s(k)$ and Eq. 4. The consideration of the $k-1$ time argument is necessary in order to perform calculations in the model. At each time step the previous values are needed in order to perform the calculation. By inserting

$$P(k - 1) = \frac{bP(k)-c+a}{d}$$

in Eq. 10 we get:

$$Q_s(k - 1) = a + \frac{b^2P(k)-bc+ab}{d} \tag{11}$$

By inserting Eq. 11 and 9 into Eq. 8 we get a simplified form of the rate equation:

$$R_Q(k) = -a + c - (b - d)P(k) \tag{12}$$

As the result of the above algebraic manipulation, the cobweb model could be stated in the standard SD form:

$$P(k + 1) = P(k) + \Delta t R_P(k) \tag{13}$$

$$R_P(k) = \frac{c+dP(k)-Q_s(k)}{b} \tag{14}$$

$$Q_s(k + 1) = Q(k) + \Delta t R_Q(k) \tag{15}$$

$$R_{Q_s}(k) = -a + c - (b - d)P(k) \tag{16}$$

with the starting conditions $P(0) = \frac{x-a}{b}$ and $Q_s(0)=x$ where x represents the starting perturbation of the model. In the above set of equations the Δt is introduced which is not present in the formulation of the classical cobweb model. If $\Delta t=1$ then the model is equivalent to the classical cobweb.

Fig. 2 shows the SD structure of the cobweb model corresponding to Eqs. 13, 14, 15 and 16. There are two levels represented, P and Q_s , and two rate elements, R_P and R_{Q_s} . The model's behaviour is determined by the input param-

eters a, b, c and d as well as by the perturbation parameter p . The element P_0 represents the initial value of the level element P . The initial value of the level element Q_s is equal to the arbitrary value of perturbation p .

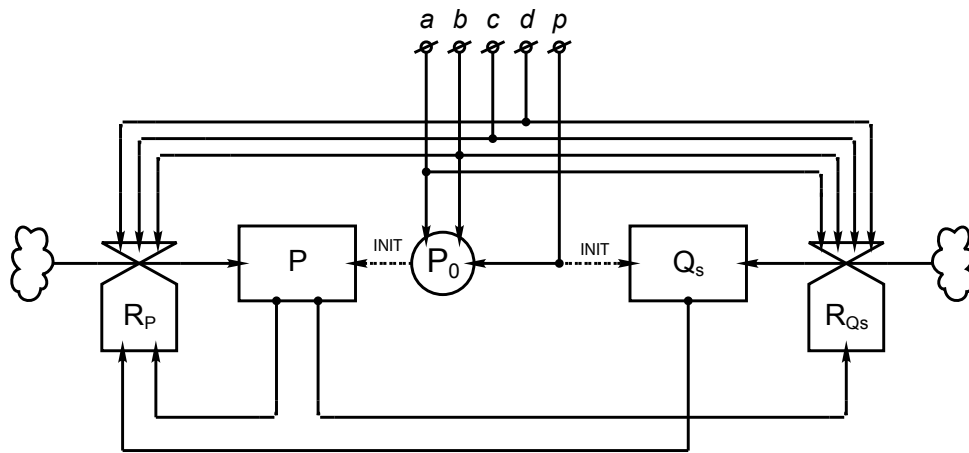

Figure 2. System Dynamics structure of the cobweb model

The response of the classic cobweb model developed by SD methodology is shown in Fig. 3 and Fig. 4. The

parameter values applied and the description of the system's response are shown in Table 1.

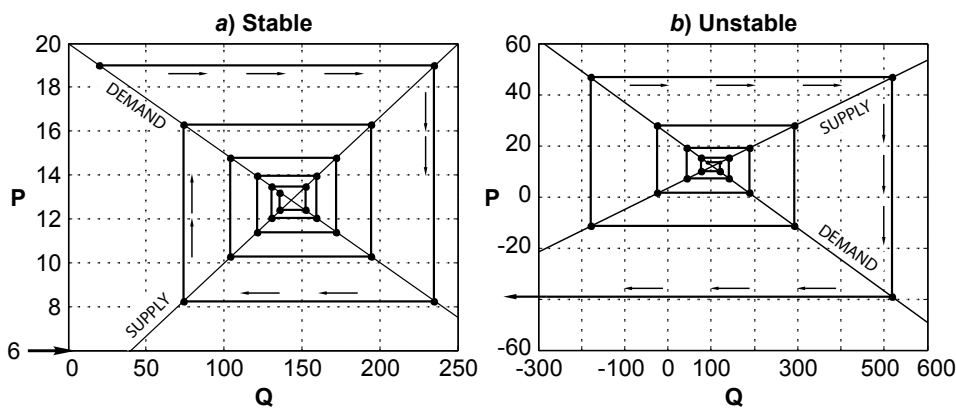

Figure 3. Response of the SD cobweb model: a) Stable, b) Unstable

Table 1. Parameter values

a	b	c	d	p	Response
400	-20	-50	15	20	Stable
200	-8.1	-43	12	90	Unstable
160	-2	-20	2	55	Dyn. Stable

There are three possibilities: a) a Stable system, where the supply and demand converge, b) an Unstable system where the supply and demand diverge and c) the Dynamically stable system shown in Fig. 4, where the price and demand neither converge nor diverge.

A dynamically stable response indicates the periodical solution that will be of interest in further examination of the model. In general a solution y_n is periodic if $y_{n+m} = y_n$ for

some fixed integer of m and all of n . The smallest integer for m is called the period of the solution. In our case the solution in Fig. 4 is a two-cycle solution and in general the following definition will be applied (Shone, 1997):

Definition 1. If a sequence $\{y_t\}$ has, for example, two repeating values y_1 and y_2 , then y_1 and y_2 are called period points and the set $\{y_1, y_2\}$ is called a periodic orbit.

This periodical response of the system is important because real agricultural systems depend on the cyclic behaviour and could be controlled only by regarding the periodicity of such systems. Examples from real cases could easily be found in crops as well as in the stock.

1 Separation of the Structural Elements

The structure of the model in Fig. 2 shows that the Price and Quantity are related. However the structure can be repre-

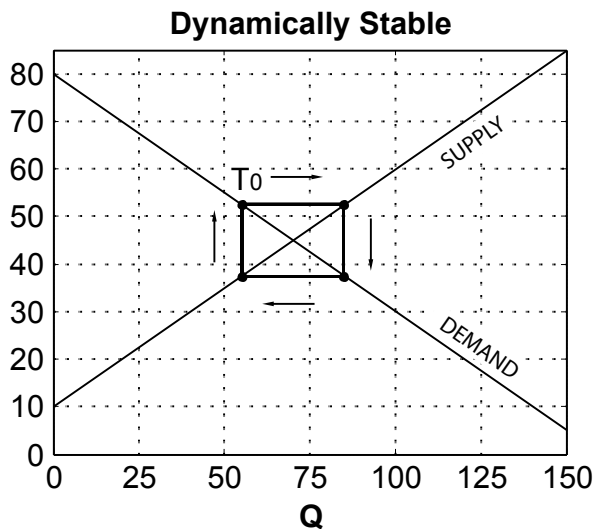

Figure 4. Response of the SD cobweb model: Dynamically stable

sented in a different way. By transforming the cobweb model into an SD form, the model could become non-autonomous depending on the variable Δt . The following two equations represent the different formulation of the cobweb model:

$$Q_s(k + 1) = c + d \frac{Q_s(k) - a}{b} \tag{17}$$

$$P(k + 1) = \frac{c + dP(k) - a}{b} \tag{18}$$

This reformulation represents Q_s and P as the non-related quantities. The only boundary that exists are the coefficients. The rate elements should be determined in order to formulate the complete SD model:

$$R_P(k) = P(k+2) - P(k+1) = \frac{c + dP(k+1) - a}{b} - \frac{c + dP(k) - a}{b} = \frac{d}{b}(P(k+1) - P(k)) \tag{19}$$

$$R_{Q_s}(k) = Q_s(k+2) - Q_s(k+1) = \frac{d}{b}(Q_s(k+1) - Q_s(k)) \tag{20}$$

In order to meet the initial conditions of the model, the $Q_s(k-1)$ should be determined:

$$Q_s(k - 1) = a + \frac{b}{d}(Q(k) - c) \tag{21}$$

Equations for P and Q_s in standard SD form are as follows:

$$P(k + 1) = P(k) + \Delta t R_P(k) \tag{22}$$

$$R_P(k) = \frac{d}{b} \left(P(k) - \frac{bP(k) - c + a}{d} \right) \tag{23}$$

$$Q_s(k + 1) = Q_s(k) + \Delta t R_{Q_s}(k) \tag{24}$$

$$R_{Q_s}(k) = \frac{d}{b} \left(Q_s(k) - \left(a + \frac{b}{d}(Q_s(k) - c) \right) \right) \tag{25}$$

Eqs. 22, 23, 24 and 25 represent the cobweb model in a separated SD form as shown in Fig. 5. Note that the terms for P and Q_s are related only to the coefficients a, b, c, d and p . $P(k+1)$ is dependent only on the value of $P(k)$ and the coefficients a, b, c, d and p , but not on Q_s . Respectively for the $Q_s(k+1)$.

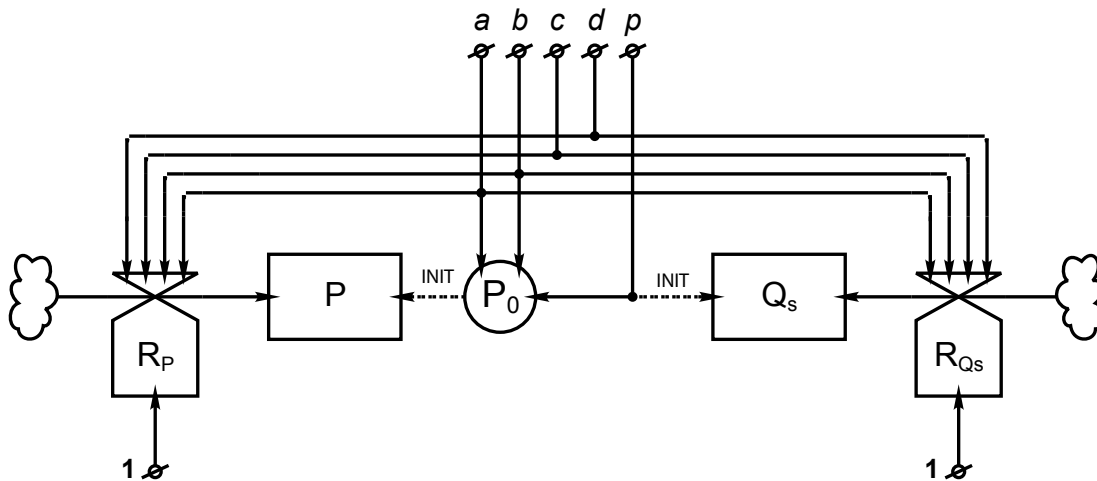

Figure 5. A cobweb model in SD form ~ separated elements

2 Anticipative Formulation

Comparison of the structures shown in Fig. 2 and Fig. 5 indicates that P and Q_s depend only on the parameter values of a, b, c, d and p , i.e. on the initial conditions. Eqs. 22, 23, 24 and 25 enable the determination of the entire anticipative (future event) chain, while the equation:

$$P(k - 1) = \frac{bP(k) - c + a}{d} \tag{26}$$

and Eq. 21 enable the determination of the feedback (past event) chain. The representation of the Feedback ~ Anticipative chain is shown in Fig. 6. The dynamics of interest are therefore the chain's dynamics that are dependant on the parameters a, b, c, d and p . Both chains are actually dependant on strategy dynamics which could be formulated as $f(a, b, c, d, p, t)$.

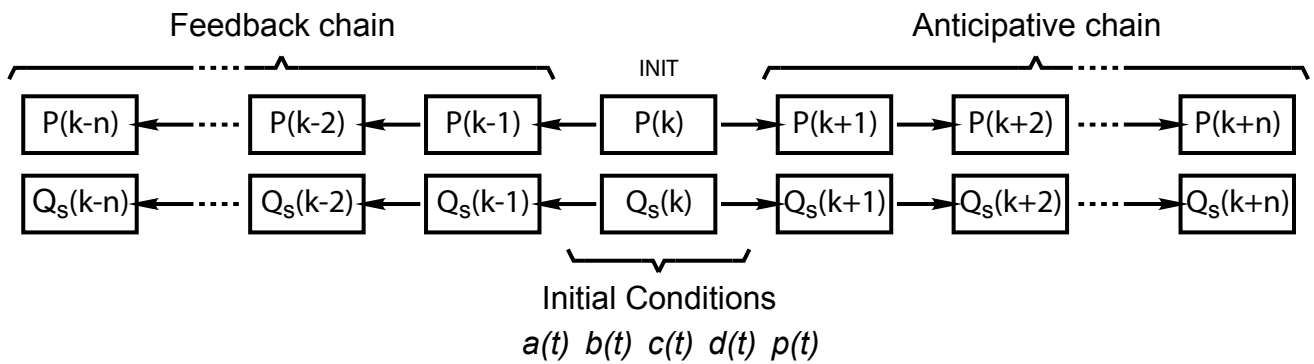

Figure 6. Feedback ~ Anticipative chain

Application of the hyperincurive algorithm and inspection of the equations gained with Dubois' (Dubois and Resconi, 1992) formulation of logistic growth and previous research (Kljajić, 1998; Kljajić, 2001; Kljajić et al., 2005), yields the following set of equations for the hyperincurive cobweb model:

$$P(k + 2) = \frac{d}{b} \left(A - \left(\frac{bB - c + a}{d} \right) \right) \tag{27}$$

$$Q_s(k + 2) = \frac{d}{b} \left(C - a - \frac{b}{d} (D - c) \right) \tag{28}$$

with the initial conditions:

$$P_0(k + 1) = \frac{p - a}{b} \tag{29}$$

$$P_0(k) = \frac{bP_0(k+1) + a - c}{d} \tag{30}$$

$$Q_{s0}(k + 1) = p \tag{31}$$

$$Q_{s0}(k) = a + \frac{b}{d} \left(Q_{s0}(k + 1) - c \right) \tag{32}$$

The coefficients A and B in Eq. 27 could be replaced by the terms $P(k+1)$ or $P(k)$ while the coefficients C and D in Eq. 28 can be replaced by $Q_s(k+1)$ or $Q_s(k)$. This yields 16 different combinations of system defined by Eqs. 27 and 28 that should be studied. The appropriate explanation of the modified system structure should follow the techniques of graphical solutions for homogenous difference equations (Puu, 1963; Azariadis, 1993).

The system combination further examined will have the following terms: $A=P(k+1)$, $B=P(k)$, $C=Q_s(k+1)$ and $D=Q_s(k)$. This yields the following set of equations:

$$P(k + 2) = \frac{d}{b} \left(P(k + 1) - \left(\frac{bP(k) - c + a}{d} \right) \right) \tag{33}$$

$$Q_s(k + 2) = \frac{d}{b} \left(Q_s(k + 1) - a - \frac{b}{d} (Q_s(k) - c) \right) \tag{34}$$

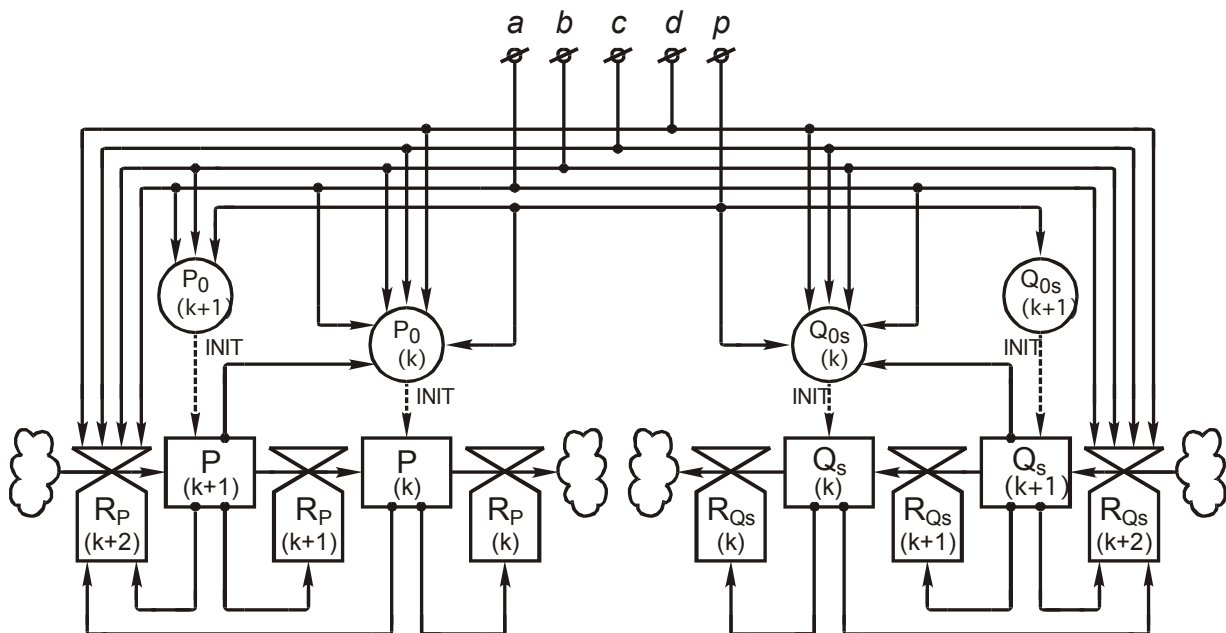

Figure 7. Structure of the hyperincurive Cobweb model; Euler integration, $\Delta t=1$

Eqs. 33 and 34 with the initial conditions stated by Eqs. 29 ~ 32 could be modelled as shown in Fig. 7. The structure represents the cobweb model in a hyperincursive form modelled using classic SD elements. The Euler integration method is applied with the time-step $\Delta t=1$.

Eqs. 33 and 34 could be reformulated in order to show the dependency of the future-present-past events as follows:

$$P(k) = \frac{bP(k-1)+a-c}{d} + \frac{b}{d}P(k+1) \tag{35}$$

$$Q_s(k) = \frac{b}{d}Q_s(k+1) + \frac{b}{d}Q_s(k-1) + a - \frac{bc}{d} \tag{36}$$

Eqs. 35 and 36 state that the value of the present is dependent on the past as well as on the future. This paradoxical statement is realizable since the formulation of a feedback ~ anticipative chain could be stated. Fig. 7 has two delay chains, one for P and one for Q_s . One might note that the level and rate elements are dependant only on the coefficients and initialization values.

3 The Periodicity of the System

The z -transform is the basis of an effective method for the solution of linear constant-coefficient difference equations. It essentially automates the process of determining the coefficients of the various geometric sequences that comprise a solution (Luenberger, 1979). The application of the z -transform on Eqs. 33 and 34, with initial conditions stated by Eqs. 29 ~ 32, gives:

$$Y(z) = \frac{-y_1 z + y_0 dz - y_0 z^2}{-1 + dz - z^2} \tag{37}$$

An inverse z -transform yields the following solution:

$$Y^{-1}(z) = 2^{-1-n} y_0 (d - \sqrt{-4 + d^2})^n - \frac{y_1 (d - \sqrt{-4 + d^2})^n}{2^n \sqrt{-4 + d^2}} + \frac{2^{-1-n} y_0 d (d - \sqrt{-4 + d^2})^n}{\sqrt{-4 + d^2}} + 2^{-1-n} y_0 (d + \sqrt{-4 + d^2})^n + \frac{y_1 (d + \sqrt{-4 + d^2})^n}{2^n \sqrt{-4 + d^2}} - \frac{2^{-1-n} y_0 d (d + \sqrt{-4 + d^2})^n}{\sqrt{-4 + d^2}} \tag{38}$$

The following equation should be solved in order to acquire the conditions for the periodic response of the system:

$$Y^{-1}(z) = y_0 \tag{39}$$

Let us compute a numerical example of a periodic solution by applying the z -transform. The period examined will be the period of 9 i.e. $n=9$. One should insert the condition $n=9$ into Eq. 39. The following possible solution for the initial condition is worth examining:

$$d = \frac{1}{\left(\frac{1}{2}(-1+i\sqrt{3})\right)^{\frac{1}{3}}} + \left(\frac{1}{2}(-1+i\sqrt{3})\right)^{\frac{1}{3}} \tag{40}$$

The term $(-1+i\sqrt{3})^{\frac{1}{3}}$ (let us denote the term as z') could be expressed in the following way using three different imaginary values in polar form:

$$z_1^* = \sqrt[3]{2} \left(\cos \frac{2\pi}{9} + i \sin \frac{2\pi}{9} \right) \tag{41}$$

$$z_2^* = \sqrt[3]{2} \left(\cos \frac{8\pi}{9} + i \sin \frac{8\pi}{9} \right) \tag{42}$$

$$z_3^* = \sqrt[3]{2} \left(\cos \frac{14\pi}{9} + i \sin \frac{14\pi}{9} \right) \tag{43}$$

By inserting Eqs. 41, 42 and 43 into Eq. 40 and performing a trigonometric reduction, one gets the following solutions:

$$d_1 = 2 \cos \frac{2\pi}{9} \quad d_2 = 2 \cos \frac{4\pi}{9} \quad d_3 = 2 \cos \frac{8\pi}{9} \tag{44}$$

By inspecting Eq. 40 and considering the equation for the roots of complex numbers (Kreyszig, 1997):

$$\sqrt[n]{z} = \sqrt[n]{r} \left(\cos \frac{\theta+2k\pi}{n} + i \sin \frac{\theta+2k\pi}{n} \right) \tag{45}$$

the general form of the solution for the parameter d could be assumed:

$$d = 2 \cos \frac{2\pi m}{n} \tag{46}$$

where n is the period and $m = 1, 2, 3, \dots, n-1$. A similar procedure could be performed for the arbitrary period of n . More general solutions, which also regard the parameter, b that was fixed for the purpose of determining the solutions, is:

$$d = 2b \cos \frac{2\pi m}{n} \tag{47}$$

In some cases the solutions could be expressed in an alternative algebraic or trigonometric form. Table 2 below shows the solutions for the parameter d up to the period of $n=12$. Alternative solutions could be expressed as the roots of the polynomial. The table incorporates the Shape symbols, which are important in the study of the response of dynamical systems. This is especially the case in the examination of complex nonlinear dynamical systems (Sonis, 1999; Matsumoto, 1997; Hommes, 1998). Mapping of the system and the visualization of the periodic solution is therefore important for the analysis of periodic or chaotic solutions of differential and discrete difference equations. The description of the shape is taken from the vocabulary of proper shapes although the response of the system is primarily not proper. The numerical values of the solutions for parameter d are important since these values also confirm the findings of Sonis (1999) on the domain of attraction for 2D dynamics by n -dimensional linear bifurcation analysis. One of the important conditions gained by the proposed inspection is the value of the period $n=10$, which is in close relation to the period $n=5$. The value of the parameter d is

$$d = \frac{\sqrt{5-1}}{2} \quad \text{with the numerical value being } d=1.61803\dots$$

This solution represents the "Golden Ratio" (Φ). Some of the different representations of the solution for the value of parameter d with period of $n=10$ are:

$$d_{10} = \phi = 2 \cos \frac{\pi}{5} = \frac{1}{2}(1 + \sqrt{5}) = 1.61803398874 \tag{48}$$

The first solution of the parameter d with the period of $n=10$ connects the discrete system considered with the Fibonacci numbers given by the infinite series:

$$d_{10} = \phi = 1 + \sum_{u=1}^{\infty} \frac{(-1)^{u+1}}{F_u F_{u+1}} \tag{49}$$

The fact that the periodicity conditions of the discrete system examined incorporates the golden ratio number Φ , could be observed in other studies (Brock and Hommes, 1997) of complex nonlinear expansions of the basic cob-web systems, e.g. in Brock and Hommes “Almost Homoclinic Tangency Lemma”. One should expect that the symmetrical response in n -mapping should follow the pattern with a synchronization match, e.g. in a certain point of the solution. The source of the condition mentioned is presented using the above procedure. (The value of parameter d for the period of $n=5$ is $d = \frac{\sqrt{5}-1}{2}$). The periodicity conditions

are similar to the parameter values gained for the domain of $2-d$ dynamic attraction by Sonis (1999). This set of parameters is augmented with two values for the periods 8 and 12, which are not stated in (Sonis, 1999).

4 Nonlinear Setup and Results

The system’s responses were gained according to the parameter values gathered in Table 2. The changes were made to parameter d , which yielded the synchronization patterns as shown in the shape column. The parameter values were

gained from the simulation, where the range of parameter d was set at $[-40, 40]$ with $\Delta d=0.001$. The condition for the determination of the parameter values was set by the rule of acceptable error between steps of the simulation and definition 1 of the synchronization.

Table 2. Parameter values at sync.

desc.	a	b	c	d	p
Triangle	400	-20	-50	20.0000	160
Quadrangle	400	-20	-50	-0.0010	160
Pentagon	400	-20	-50	-12.3671	160
Pentagram	400	-20	-50	32.3620	160
Hexagon	400	-20	-50	-20.0000	160
Nonagram	400	-20	-50	-6.9450	160
Hexagram	400	-20	-50	15.3070	160

Let us consider the following expansion of the model (Škraba et al., 2005, Škraba et al., 2006) and let us define the adaptive nonlinear rule R as:

$$R = \begin{cases} \frac{P_{k+1} - P_k}{P_k} & \text{if } -1 < \frac{P_{k+1} - P_k}{P_k} < 1 \\ 1 & \text{if } \frac{P_{k+1} - P_k}{P_k} \geq 1 \\ -1 & \text{if } \frac{P_{k+1} - P_k}{P_k} \leq -1 \end{cases} \tag{50}$$

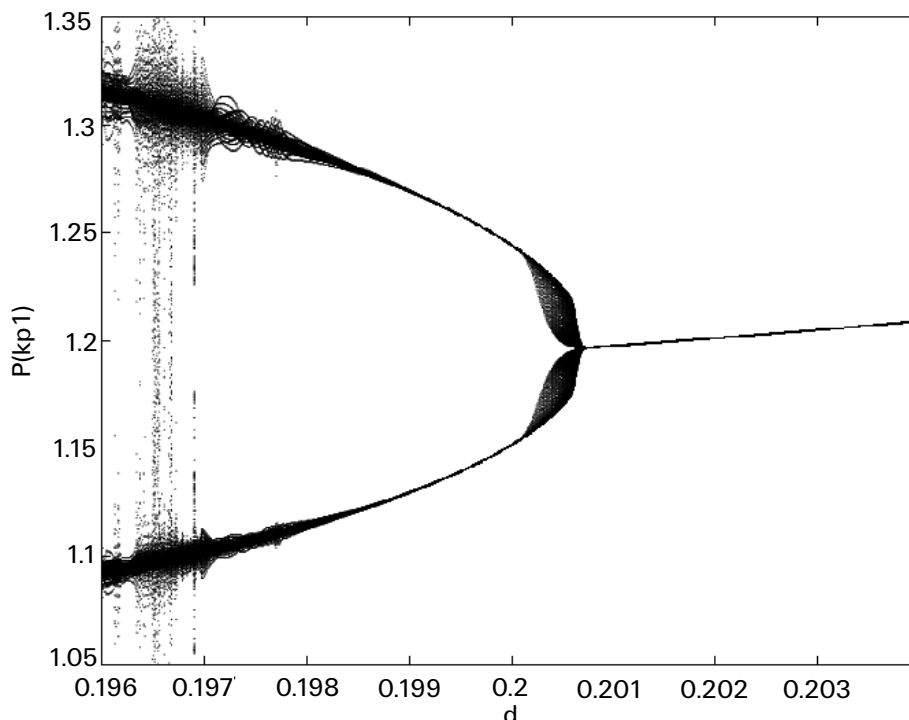

Figure 8. Bifurcation diagram in the range $d \in [0.196, 0.204]$

Since the forced nonlinear rule has been applied, we have arrived at the characteristic nonlinear bifurcation diagram. Let us observe the response of the system at the period of $p=6$ as one of the polygon rules, which should provide the periodicity of the system considered. The beginning of the bifurcation corresponds to the value of the parameter $d=1$, which has been indicated in the analysis of the initial 2-d discrete map. Period six is followed by $p=7$ and $p=8$. However, the analytical proof of the periodicity would be hard since the underlying Farey sequence defines the adapted nonlinear 2-d discrete map. Such evidence is also found in other works on nonlinear system analysis, for example (Brock and Hommes, 1997; Gallas and Nusse, 1996) or in the recent works of Puu (Puu and Shushko, 2004; Puu, 2005).

Consider another generic alteration of the initial anticipative cobweb model:

$$\begin{aligned}
 P_K(k+1) &= P_K + P_{KP1}(k) - \left(P_K(k) + \frac{1}{P_Z(k)P_K(k)} \right) \\
 P_{KP1}(k+1) &= P_{KP2}(k) \\
 P_{KP2}(k+1) &= \frac{d}{b} \left(P_{KP1} - \frac{bP_K(k)-c+a}{d} \right) \\
 P_Z(k+1) &= P_Z(k) + P_K(k)P_{KP1}(k) - vP_Z(k) \quad (51)
 \end{aligned}$$

Slight modification of initial Hicks' model (Puu, 1963) gives this interesting response. The system can be represented in three dimensions, which reveals the periodicity of the system for which the previously determined conditions of the Farey tree generally still hold. Fig. 9 shows the 3d bifurcation diagram for the altered model. You can see the four attractors, which are simultaneous and represent the four possible equilibrium states for the trade dynamics. This 4-cycle characteristic is preserved during the alteration of the parameter d , which can be observed in the Fig. 10. The

four dots on the centre-right side of the figure represent the four-cycle characteristic of the response. The larger orbits indicate the steep change in the modulus of the system.

In order to analyze the preservation of the periodic solutions, the most significant periodic solution, i.e. the period of 6, has been applied to the system in Eq. 50, which is restated in the following form:

$$\begin{aligned}
 P_{KP1} &= \frac{d}{b} P_{KP1} - P_K + c - a \\
 P_K &= P_{KP1} - \frac{1}{P_Z P_K} \\
 P_Z &= P_Z(1 - v) + P_{KP1} P_K \quad (52)
 \end{aligned}$$

This proposed model, with certain limitations, yields the periodicity solutions that are related to the system attractor. For example, for period 10 the initial values are: $P_{KP1}=-1$, $P_{KP1}=-1.61803$, $P_Z=1.61803$, $d=1.61803$ and $v=1$. Fig. 11 represents the response of the system for period 6, where the parameter $d=1$. The starting points of the attractor are from the interval $(-2, 2)$. The simulation for the determination of the attractor was performed using 30,000 random starting points. Fig. 12 shows the period 6 attractor with 6 attractive regions, which are doubled, actually making 12 beams of periodicity. The centre of the attractor reveals the distinguishing 6-sided polygon shape. Fig. 12 shows a magnification of the centre of the period 6 attractor.

5 Conclusion

The story revealed from the hyperincursive model developed here raises the following questions: a) Does a change in the strategy change the structure or does it only change the relations between the elements of that structure? b) Does a change in the strategy change the future as well as the past?

A change in the strategy would mean a new and differ-

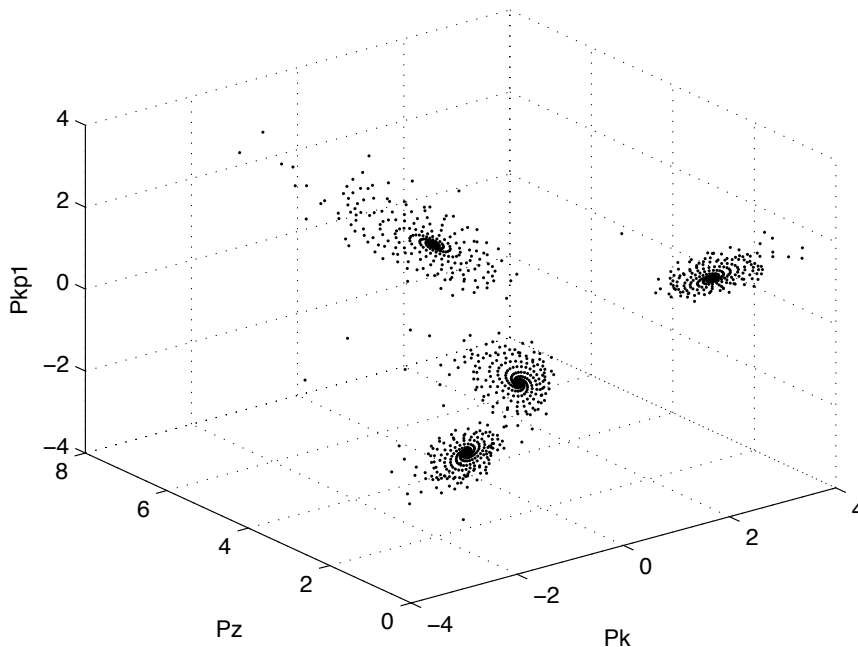

Figure 9. The emergence of four synchronous attractors in the nonlinear situation where $d=0.26131278$ and $b=0.33$

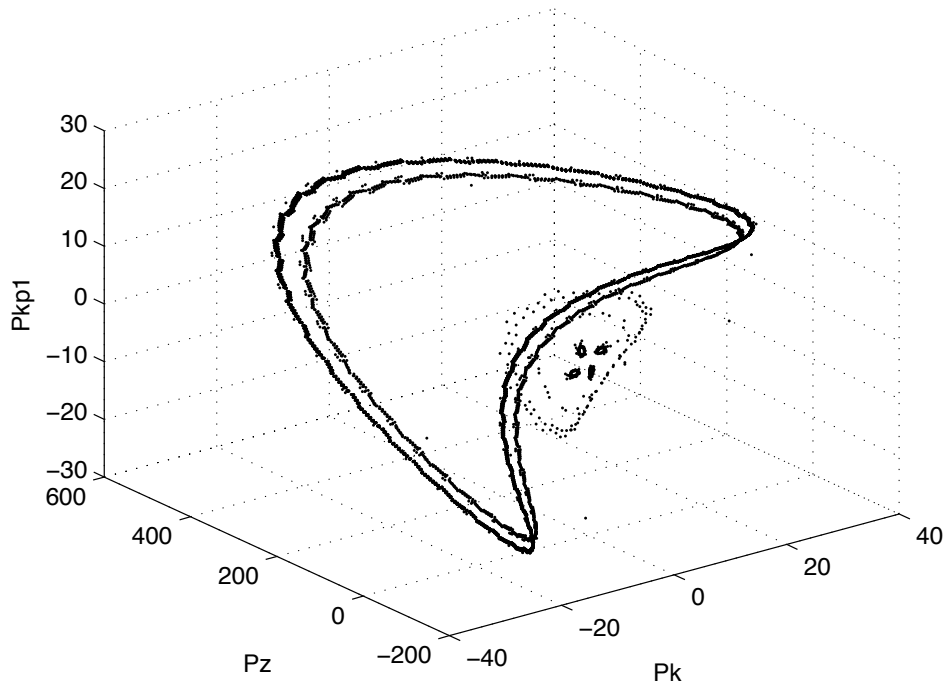

Figure 10. The preservation of four synchronous attractors in the nonlinear situation where $d=0.26151152$ and $b=0.33$

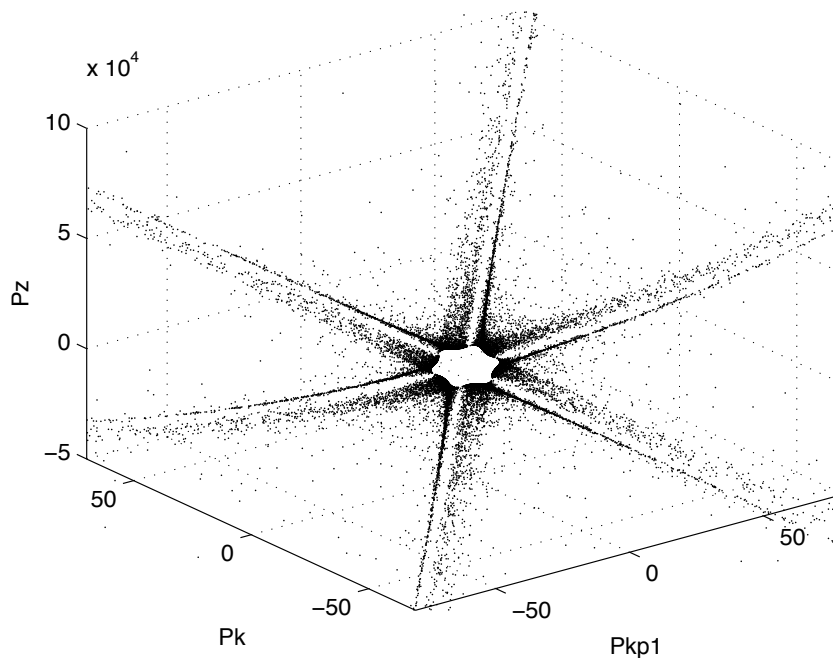

Figure 11. The period 6 attractor with the parameters: $d=1$, $b=1$ and $v=1$

ent future and should also mean a different past if the strategy change occurred earlier. The hyperincursive cobweb model consideration enables us to change the future as well as the past chain of events. However, a different examination of the system dynamics is proposed where change in the key parameters is performed while observing the change in a complete future and past chain rather than observing the classical time response of the system.

The following procedure proposition emerges, which enables the anticipative formulation of the classical dynamic system. Since the hyperincursive systems are hard to determine (Dubois and Resconi, 1992; Rosen, 1985), the anticipatory mechanisms developed should be applied. Therefore, the model should a) be transformed into the separated form, b) provide the property of the past-future chain and c) apply the hyperincursive structure to the model studied.

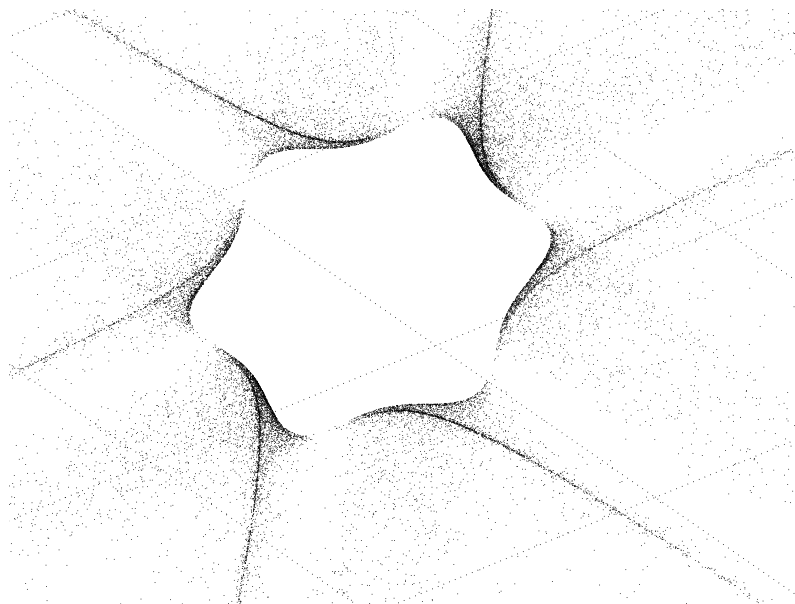

Figure 12. A magnification of the centre of the period 6 attractor from Fig. 11 with the parameters: $d=1$, $b=1$ and $v=1$

The model developed shows that, by the statement of the general rule of the system, the synchronization of the entire feedback-anticipative chain could be gained by setting the appropriate strategy in the form of the value of the parameters set, which should be time dependant.

The idea for the simulation proposed in this paper is quite different from the common paradigm. The structure of the model should yield the entire feedback-anticipative chain and observation should be made of the entire system response. This provides new and quite challenging responses that should initiate further interest and examination of the proposed model.

One of the interesting responses from the model is the helix like shape that is synchronized at certain time steps. The entire feedback-anticipative chain, i.e. all the point set, is synchronized according to the period of the system. The solution of the periodicity conditions for the $2-d$ discrete linear cobweb map provided the means to determine these periodicity conditions and an analytical approach using z -transformation provides the proper way to determine the periodic solutions. The emergence of a Farey tree as the rational fraction representation yields the organization of the periodicity solutions. The model developed shows that, by the statement of the general rule of the system, the synchronization of the entire feedback-anticipative chain could be achieved by setting the appropriate strategy in the form of the value of the parameters set, which should be time dependant. The bifurcation experiment with the nonlinear mapping provided the example of periodicity transposition to systems of higher complexities. Period 6 has been determined as one of the most stable periodic solutions, as has been explicitly shown by the analysis of system's attractors.

Literature

- Azariadis C. (1993). *Intertemporal Macroeconomics*. Blackwell Publishers. Cambridge MA.
- Brock, W. A. & Hommes, C. H. (1997) A rational route to randomness. *Econometrica* **65**(5): 1059 – 1095.
- Dubois D. & Resconi G. (1992). *Hyperincurisvity - a new mathematical theory*, 1st ed. Presses Universitaires de Liège.
- Gallas, J. & Nusse, H. E. (1996). Periodicity versus chaos in the dynamics of cobweb models. *Journal Of Economic Behavior & Organization*, **29**: 447 – 464.
- Hommes, C. H. (1998). On the consistency of backward-looking expectations: The case of the cobweb. *Journal Of Economic Behavior & Organization*, **33**: 333 – 362.
- Kljajić M. (1998). Modeling and Understanding the Complex System Within Cybernetics. Ramaekers M. J. (Ed.), *15th International Congress on Cybernetics*. Association International de Cybernetique. Namur, pp. 864 – 869.
- Kljajić M. (2001). Contribution to the meaning and understanding of anticipatory systems. Dubois D. M. (Ed.). *Computing anticipatory systems*, (AIP conference proceedings, 573). Melville (New York): American Institute of Physics, pp. 400 – 411.
- Kljajić, M., Škraba, A., Kofjač, D. & Bren, M., (2005). Discrete Cobweb Model Dynamics with Anticipative Structure. *WSEAS Transactions on Systems*. **4**(5): pp. 196-203.
- Kreyszig, E. (1993) *Advanced Engineering Mathematics*. 7th ed. John & Wiley Sons Inc.
- Luenberger, D. G. (1979). *Introduction to Dynamics Systems - Theory, Models & Applications*. John & Wiley Sons Inc.
- Matsumoto, A. (1997). Ergodic cobweb chaos. *Discrete Dynamics in Nature and Society*, **1**: 135 – 146.
- Puu T. (1963). A Graphical Solution of Second-Order Homogeneous Difference Equations. *Oxford Economic Papers*. Mar 1963; **15**(1): 53-58.
- Puu T. (2005). On the Genesis of Hexagonal Shapes Tõnu Puu. *Networks and Spatial Economics*. **5**(1): 5-20.
- Puu T. & Sushko I. (2004). A business cycle model with cubic non-linearity. *Chaos, Solitons and Fractals*, **19**: 597–612.
- Rosen R. (1985). *Anticipatory Systems*. Pergamon Press.

- Rosser. M. (2003). *Basic Mathematics for Economists*, 2nd ed. Routledge.
- Shone. R. (1997). *Economic Dynamics*. Cambridge University Press.
- Škraba, A., Kljajić, M., Kofjač, D. Bren, M. & Mrkaić M. (2005). Periodic Cycles in Discrete Cobweb Model. *WSEAS Transactions on Mathematics*, 3(4): 196-203.
- Škraba, A., Kljajić, M., Kofjač, D. Bren, M. & Mrkaić M. (2006). Anticipative Cobweb Oscillatory Agents and Determination of Stability Regions by Lyapunov Exponents. *WSEAS Transactions on Mathematics*, 5(12): 1282-1289.
- Sonis, M. (1999). Critical Bifurcation Surfaces of 3D Discrete Dynamics. *Discrete Dynamics in Nature and Society*, 4 (3). 333-343.
- Wiener N. (1961). *Cybernetics or Control and Communication in the Animal*. MIT Press: Cambridge, MA.

Acknowledgement

This research was supported by the Ministry of Higher Education, Science and Technology of the Republic of Slovenia (Program No. UNI-MB-0586-P5-0018).

Andrej Škraba obtained his Ph.D. in the field of Organizational Sciences from the University of Maribor. He works as a researcher, teaching assistant and assistant professor at the University of Maribor, Faculty of Organizational Sciences in Cybernetics and DSS Laboratory. His research interest covers modelling and simulation, system dynamics, decision processes and multiple criteria decision-making. Recently his interests have been focused on the analysis of nonlinear chaotic systems.

Davorin Kofjač received his Associate's degree in computer science at the Faculty of Electrical Engineering and Computer Science in Maribor in 1999. He achieved his B.Sc. degree in information systems management at the Faculty of Organizational Sciences in Kranj in 2002. Currently he is working as a young researcher at the Faculty of Organizational Sciences. His research interests include modeling and simulation, artificial intelligence and operational research.

Črtomir Rozman achieved his PhD. at University of Maribor, Faculty of Agriculture. He is active as Assistant Professor for Farm management and Agronomic information systems in the Department for Agriculture Economics and Rural Development (Faculty of Agriculture, University of Maribor). His research includes development of DSS for farm management (simulation modelling, multi criteria decision analysis) and economics of agricultural production with the emphasis on organic agriculture. He is also involved in teaching activities as Head of Department and as thesis supervisor at post graduate study programmes. He is author or coauthor of 121 papers including 6 papers in journals with impact factor.
