

Ugotavljanje nosilnosti materialov za aluminijška platišča

Load Carrying Capacity Analysis of Materials for Aluminium Rims

Jure Čižman - Matija Fajdiga

V prispevku je prikazano eksperimentalno simuliranje obratovalne trdnosti vpetja aluminijških platišč, ki poteka z uporabo numeričnega modeliranja s postopkom končnih elementov (MKE), s katerim je opravljena napetostno-deformacijska analiza zasnovanega modela detajla upogibnega vpetja. Gradnja in analiza modela potekata interaktivno s snovanjem integriranega računalniško vodenega namenskega preskuševališča za preskušanje obratovalne trdnosti upogibnih vpetij. Simuliranje je ovrednoteno na podlagi rezultatov preskusov obratovalne trdnosti.

© 1999 Strojniški vestnik. Vse pravice pridržane.

(Ključne besede: trdnost obratovalna, aluminij, simuliranje numerično, krivulje vzdržljivosti)

In this contribution we present an experimental simulation of the fatigue strength of clamped aluminum rims. This is supported by numerical modelling using the Finite Element Method (FEM), which was used for stress-strain analyses of a model representing a clamped detail during bending. The design and analysis of the model are made simultaneously on an integrated computer controlled test rig for testing the fatigue strength of clamped parts subjected to bending. The simulation is evaluated on the basis of results of operational strength tests.

© 1999 Journal of Mechanical Engineering. All rights reserved.

(Keywords: operational strength, aluminium, numerical simulation, durability curves)

0 UVOD

V praksi imamo pogosto opravka z dinamično obremenjenimi nosilnimi konstrukcijami (npr. vozila) ali elementi, ki so še posebej izpostavljeni različnim oblikam utrujanj, te pa praviloma zmanjšujejo zdržljivost nosilnega elementa oziroma skrajšujejo njegovo življenjsko dobo ([2], [8] in [11]). Ker je obratovalna trdnost konstrukcijskega elementa lastnost, na katero vpliva več naključnih parametrov (obremenitve, geometrijske karakteristike, izdelava, pogoji uporabe) in je ni mogoče natančno analitično vrednotiti, je za zanesljivejšo oceno življenjske dobe oziroma obratovalne trdnosti za specifične primere uporabe treba opraviti ustrezne eksperimentalne analize ([1], [2], [3], [6] in [8]).

Postopek ugotavljanja nosilnosti Al zlitin poteka z uporabo numeričnega modeliranja ([3], [5] in [7]). To omogoča napetostno-deformacijske analize modela zasnovanega detajla upogibnega vpetja in s tem oceno napetostnih in drsnih razmer v vpetju, ki so pomembne za tribološke analize [10]. Interaktivno z numerično analizo poteka preskušanje na namenskem računalniško vodenem preskuševališču obratovalne trdnosti.

0 INTRODUCTION

In practical situations, dynamically loaded structures (e.g. vehicles) and elements that are subject to different forms of fatigue tend to suffer a reduction in endurance and a shortening of their lifetime ([2], [8] and [11]). As the service fatigue strength of a component is a property influenced by different parameters (loading, design, material behaviour, manufacturing, environmental service conditions) and is difficult to evaluate analytically, suitable experimental analyses for a more reliable estimation of the fatigue life in specific applications are required ([1], [2], [3], [6] and [8]).

The process of load carrying capacity assessment of Al-alloys is performed by numerical modelling ([3], [5] and [7]). Modelling allows the stress-strain analyses of a fabricated clamping detail subjected to bending, and thus it is possible to estimate the stress, deformation and slip conditions during clamping, which is significant for tribological analyses [10]. Operational strength testing, on an integrated computer controlled testing facility, runs at the same time as the numerical analysis.

1 MODELIRANJE IN NUMERIČNO
SIMULIRANJE

Pod vplivom osnovnih delovnih dinamičnih obremenitev se na mestu vpetja pogosto pojavljajo majhni relativni premiki, ki praviloma pospešijo proces utrujanja. Obseg vplivov je odvisen od specifičnih razmer v taki zvezi (korozija, mikro zdrsi). Izkušnje ([1], [3], [4], [5], [7] in [11]) kažejo, da je prav detalj vpetja eno od najpogostejših kritičnih mest, saj se razpoke v materialu pojavljajo prej, kakor bi bilo pričakovati na podlagi analiz preskusov obratovalne trdnosti za primer osnovne delovne obremenitve.

Na sliki 1-a je prikazan dejanski sklop platišče - os, za analizo katerega je bil oblikovan preskusni model ter zasnovan preskušane (sl. 1-c), ki je v modelu nosilni element. Obremenitev, ki izhaja iz stika med kolesom in vozno površino, se prek pnevmatike prenese na platišče in v njem povzroči večosno napetostno stanje, katerega največji delež zaradi razmeroma majhne upogibne togosti (v primerjavi s torzijsko togostjo) predstavljajo upogibne napetosti. Poleg njih so na mestih vijčnih spojev zaradi spenjalne sile tudi lokalne tlačne napetosti.

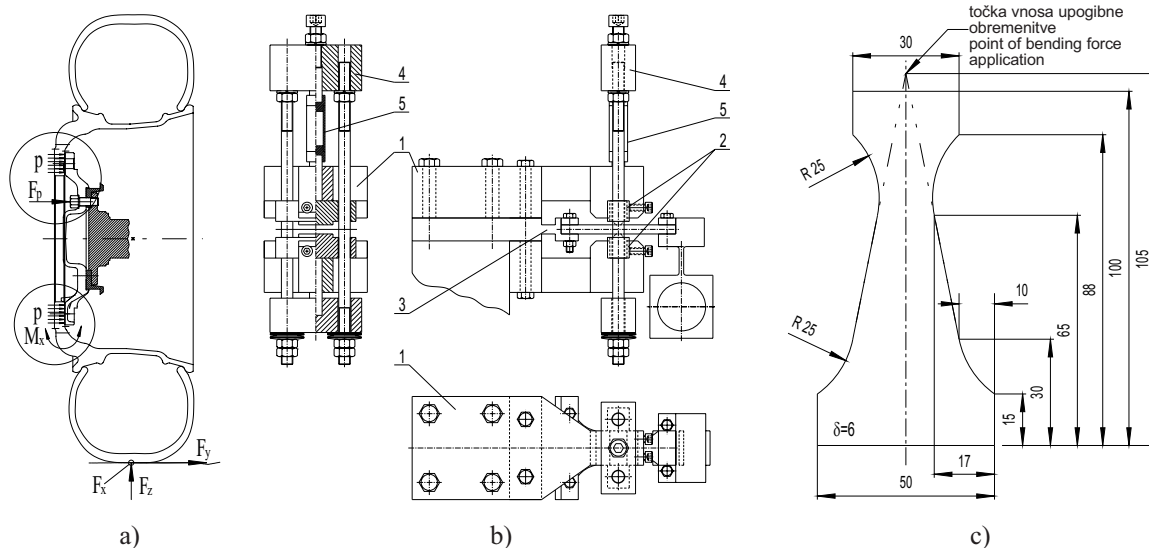

Sl. 1. Obremenitve sklopa platišče – os (a), sklop čeljusti s spenjalnimi kladicami (b) in preskušane za ravninski upogibni preskus (c)

Fig. 1. Loading of rim – axle joint (a), rigid frame and clamping pads (b) and specimen for plane-reverse bending test (c)

Najprej je bil pripravljen model dejanskega stanja na kolesnem sklopu, vključujoč vse parametre, ki imajo bolj ali manj pomemben vpliv na obratovalne razmere. Oblikovan model simuliranja vpetja je predstavljen na sliki 1-b. Najpomembnejši elementi so toge čeljusti (1), spenjalni kladici (2), fiksno vpenjalo (3), jarem (4) ter sonda za merjenje spenjalnega tlaka (5).

Spenjalni kladici imata plosko oblikovano pritiskno površino z zaobljenim robom, narejeni pa

1 MODELLING AND NUMERICAL
SIMULATION

Under the influence of operational dynamic loading small relative displacements, that as a rule advance fatigue process, frequently appear at the point of clamping. The extent of the influence depends on the actual conditions at the connection (corrosion, micro slip). Previous studies ([1], [3], [4], [5], [7] and [11]) have shown that the clamping detail is commonly the most critical area on the wheel, as cracks occur there earlier than is expected on the basis of fatigue tests for the elementary loading state.

In Figure 1-a an actual rim – axle joint is shown. In order to analyse the joint an experimental model was created and a specimen (Fig. 1-c), which is a load carrying element in the model, was designed. The loading, originating from the contact between the wheel and the cart surface, transfers through the pneumatic tyre to the rim, where a multiaxial stress state occurs. The most significant of which are bending stresses, owing to the relatively small bending stiffness in comparison with the torsional stiffness. Additional local compressive stresses are due to the clamping force also present at the location of the screw-joints.

First, a realistic condition of the wheel was modelled so that the simulation model included all the parameters which have an influence on the operational conditions. The designed model of the clamping simulation is presented in Figure 1-b. Its main parts are a rigid frame (1), clamping pads (2), fixing of the specimen (3), clamping yoke (4) and a probe for measuring the clamping force (5).

The clamping pads have a flat clamping surface with a rounded edge and are made from St

sta iz jekla St 37-3 (DIN). Preskušavec je oblikovan kot telo enakih upogibnih napetosti in je izdelan iz enakih materialov (AlSi7Mg0,6wa ali AlSi11MgSr) in po enakih postopkih (litje, frezanje, peskanje) kot platišče.

Oblikovanje numeričnega modela

Numerična analiza upogibnega vpetja je bila opravljena z metodo končnih elementov (I-DEAS Master Series 4.0 / SDRC) na delovni postaji Indigo 2 (Silicon Graphics).

Cilj analize napetosti in relativnih pomikov v stiku je čimboljša ocena dejanskih obratovalnih razmer v simuliranem vpetju za preliminarno ovrednotenje pričakovanega dejanskega stanja med preskusom. Model je sestavljen iz 16864 linearnih prostorskih elementov (sl. 2-a), mreža pa je najgostejša na mestu stika med spenjalnima kladicama in preskušancem (sl. 2-b).

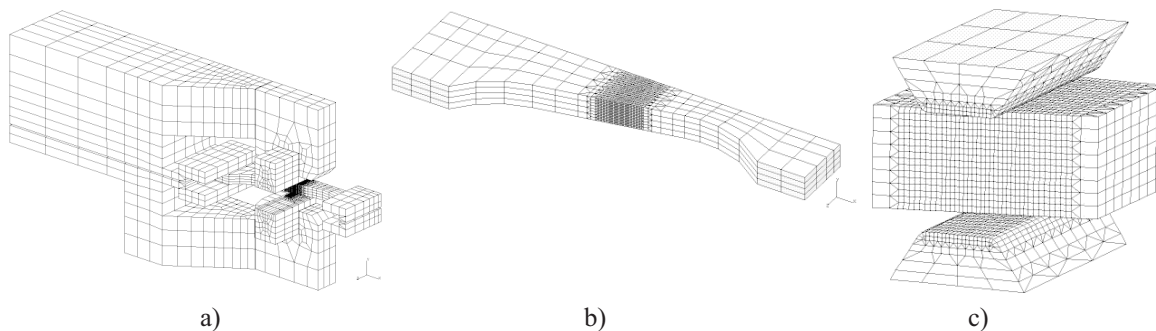

Sl. 2. Model vpetja (a) in preskušanca (b) ter detajl stika (c)
Fig. 2. Clamping model (a), specimen (b) and contact detail (c)

Povezava med vozlišči v stiku je opravljena z uporabo t.i. “režnih” (“gap”) elementov, ki omogočajo vzpostavitev modela stika. Vrednost koeficienta trenja je bila pridobljena interaktivno s tribološkimi analizami [10], pri katerih je bil ugotovljen tudi vpliv velikosti površinskih tlakov in relativnih premikov na izmerjen koeficient trenja in znaša $\mu = 0,14$. Meritve so bile opravljene le za kombinacijo materialov AlSi7Mg0,6wa (preskušavec) in St37-3 (spenjalna kladica). Zaradi ocene vpliva površinskega (spenjalnega) tlaka na porazdelitev napetosti in relativnih premikov v stiku med spenjalnima kladicama in preskušancem je bila opravljena numerična analiza za tri karakteristične (srednje) vrednosti spenjalnega tlaka (20, 40 in 100 MPa).

Zahtevana velikost relativnih premikov izhaja iz dejanskih razmer v vijačni zvezi obravnavanega konstrukcijskega sklopa pri pogojih delovne obremenitve. Največja amplituda relativnega premika (zdrsa) mora biti med 5 μm in 15 μm , odvisno od velikosti spenjalnega tlaka.

Na preskušavec delujeta upogibna sila ($F_b = 120\text{ N}$) na strani prostega krajišča in površinski

37-3 (DIN) steel. The specimen is shaped as an equal bending stress body and is manufactured from the same material (AlSi7Mg0,6wa or AlSi11MgSr) and by same processes (casting, milling and shot peening) as the rim.

Numerical modelling

Numerical analysis of the bending clamping was executed using the Finite Element Method (I-DEAS Master Series 4.0 / SDRC) on an Indigo 2 (Silicon Graphics) work station.

The aim of the stress and relative displacement (slip) analysis in the contact was to be an as exact as possible estimation of the actual operational conditions in the simulated clamping for preliminary evaluation of an expected actual state during an experiment. The model was made of 16864 solid linear brick elements (Fig. 2-a), in which the mesh is the most compact in the connection between the clamping pads and the specimen (Fig. 2-b).

The connection between nodes in the contact is achieved by gap elements which enable contact modelling. The coefficient of friction was acquired by means of tribological analyses. The influence of the surface pressure and relative displacements on the measured coefficient of friction was determined and found to be 0.14. Measurements were performed only for the material combination AlSi7Mg0,6wa (specimen) and St37-3 (clamping pad). Owing to an assessment of the influence of the surface (clamping) pressure magnitude on the stress and relative displacement distribution in the contact between clamping pad and specimen, numerical analyses for three characteristic (mean) values of the clamping pressure: 20, 40 and 100 MPa were carried out.

The required relative displacement magnitude originates from the actual conditions in the screw joints of the treated structure under operational loading. The maximum relative displacement (slip) amplitude should be between 5 μm and 15 μm , depending on the selected clamping pressure value.

The bending force ($F_b = 120\text{ N}$) acts upon the specimen at the end of the movable edge, the

tlak ($p_1 = 20$ MPa, $p_2 = 40$ MPa ali $p_3 = 100$ MPa) na mestu stika, kar je prikazano na sliki 3. Podprtje in drugi robni pogoji so izvedeni v skladu z dejansko zasnovo detajla vpetja, upoštevajoč simetričnost modela na prerezni ravnini.

clamping pressure ($p_1 = 20$ MPa, $p_2 = 40$ MPa or $p_3 = 100$ MPa) is introduced in the contact, as is shown in Figure 3. Constraints and other boundary conditions are accomplished in accordance with the actual design of the clamping detail, taking into account the symmetry of the model on the section plane.

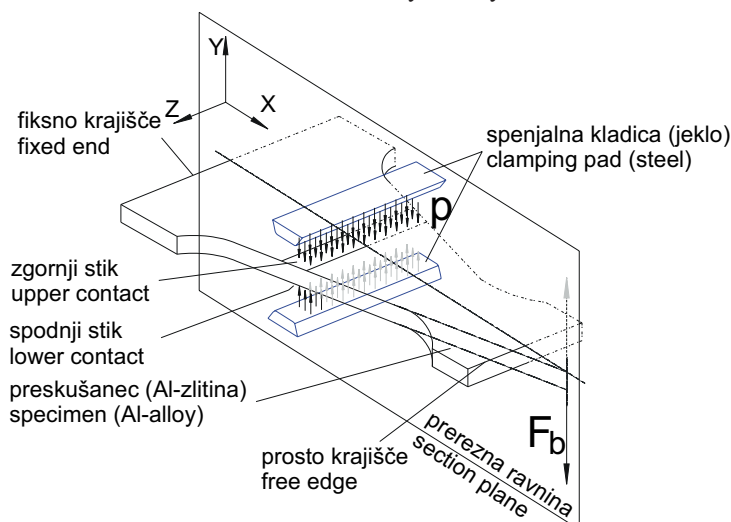

Sl. 3. Simetričnost modela preskušanca
Fig. 3. Symmetry of the model of the specimen

2 REZULTATI ANALIZE NAPETOSTNIH IN DRSNIH RAZMER V STIKU

2 RESULTS OF ANALYSIS OF STRESS AND SLIP CONDITIONS IN THE CONTACT

Relativni premiki

Analiza relativnih premikov v stiku omogoča sklepe o izbiri ustrezne velikosti spenjalnega tlaka pri preskusih.

V preglednici 1 je prikazano stanje relativnih premikov in ocena največjega skupnega relativnega premika po vozliščih v stiku za različne spenjalne tlake ter največje vrednosti relativnih premikov glede na srednji tlak v kontaktu.

Iz diagramov, v katerih sta komponenti relativnih premikov v smeri osi X in Y obravnavani ločeno (sl. 4), je razvidno, da je obseg območja naleganja spenjalne kladice in preskušanca odvisen od velikosti spenjalnega tlaka.

Napetosti

Napredovanje utrujenostne poškodbe je odvisno predvsem od največje izmenične glavne napetosti, poteka pa pravokotno na smer njenega delovanja, zato so te pomembne za oceno lokacije poškodb v odvisnosti od obremenitvenega stanja. Porazdelitev napetosti, pravokotnih na stično površino (Y), kaže na neke vrste zarezni vpliv in je prav tako pomemben parameter za analizo vpliva zdrsa na utrujanje. Primerjava napetosti Y kaže značilne konice napetosti na zunanem robu spodnje

Relative displacements

Analysis of the relative displacements in the contact enables decisions about the selection of a suitable clamping pressure during testing.

Relative displacement conditions and their estimated maximum total size over the nodes in the contact for different clamping pressures and maximum magnitudes of relative displacements with regard to the mean clamping pressure in the contact are shown in Table 1.

From the diagrams in Fig. 4 showing the X and Y displacement components of each contact node it is evident that the range of connection between contacting parts depends upon the size of the clamping force.

Stresses

The growth of fatigue damage, after crack initiation, depends mostly on the maximum alternating principal stresses and progresses perpendicularly to their direction. As a result, they are important for the estimation of the relationship between damage location, and the operating conditions. The distribution of stresses, acting perpendicularly to the contact surface (Y) direction, shows the presence of a kind of notch effect and is also an important parameter for the analysis of slip influence on fatigue. The comparison of Y-stresses

Preglednica 1. Največji delni in skupni (ocenjeni) relativni premiki v stiku
 Table 1. Maximum partial and estimated total relative displacements in the contact

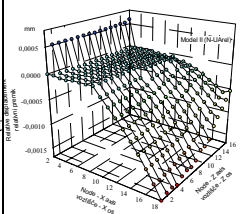
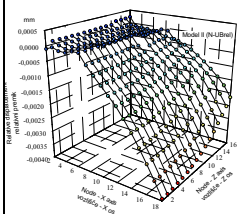
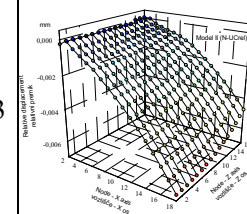
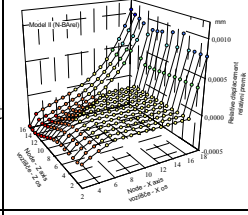
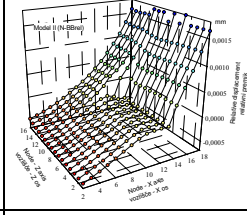
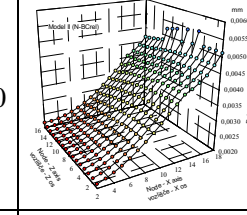
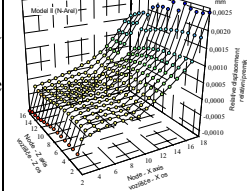
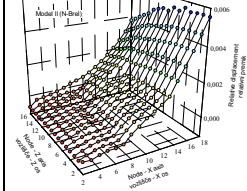
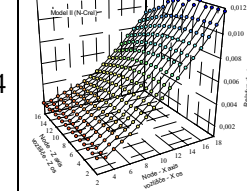
primer / case	A		B		C	
\bar{p} (MPa)	100		40		20	
	porazdelitve in najv. vrednosti / distribution and max. value (μm)					
relativni premiki na zgornji stični ploskvi / relative displacement on upper contact surface		1.70		3.93		6.66
relativni premiki na spodnji stični ploskvi / relative displacement on lower contact surface		1.27		1.80		5.51
ocena največjega skupnega relativnega premika v stiku / estimated max. value of relative displacement in contact		2.53		5.64		12.07

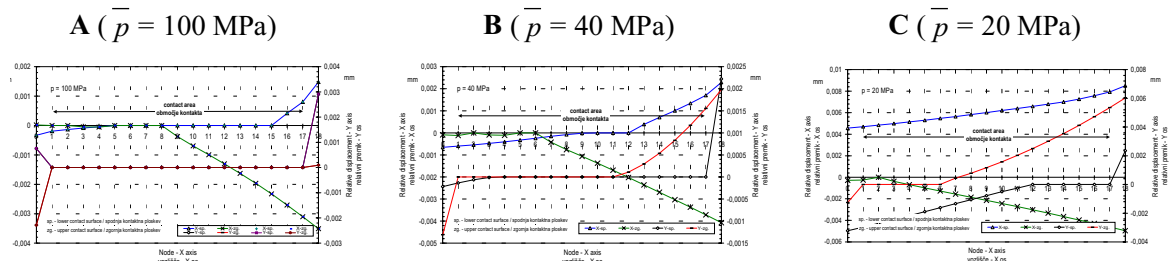

Sl. 4. Komponenti relativnih premikov v smeri X in Y za stičnico 1 (vzdolž osi X)
 Fig. 4. Relative displacement components in X and Y directions for contact line 1 (along X axis)

stične površine in na notranjem robu zgornje. Skoki napetosti so jasneje izraženi pri manjših spenjalnih tlakih (pregl. 2), pri katerih se celotna upogibna obremenitev s preskušanca na spenjalno kladico prenese le prek zelo omejene stične površine.

Rezultati analize največjih glavnih napetosti (sl. 5) in nateznih oziroma tlačnih napetosti v smeri osi X (sl. 6-a in 6-b) kažejo, da kritična točka ne leži v območju stične ploskve, ampak je od njenega zunanega roba odmaknjena navzven (proti prijemališču upogibne sile) za 0,5 do 2 mm. Velikost odmika je odvisna od velikosti spenjalnega tlaka. Natezne (X) napetosti in največje glavne napetosti v območju, kamor sodi ocenjena kritična točka in v katerem je pričakovati porušitev preskušanca (vozlišče - X os: 22 do 27), se malodane ujemajo.

shows the distinctive stress peaks on the outer edge of the lower contacting area and on the inner edge of the upper one. Stress peaks are more evident if the clamping pressure is lower (Tab. 2), where the total bending load transfers from the specimen to the clamping pad over very limited contact area.

Results of the maximum principal (Fig. 5) and normal stress (X axis) analyses (Figs. 6-a and 6-b) indicate that the position of the critical point is not within the contact area, but is shifted by 0.5 to 2 mm from the outer edge (towards the bending force acting-point). The size of the shift depends on the magnitude of the clamping stress. Normal (X) and maximum principal stresses in the area where an estimated critical point is located and where fracture of the specimen is expected (nodes in X axis: 22 to 27) nearly coincide.

Preglednica 2. Porazdelitev napetosti Y na zgornji in spodnji stični ploskvi
Table 2. Y -stress distribution on the upper and lower contact surfaces

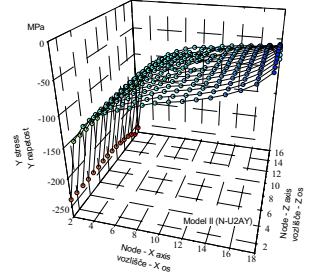
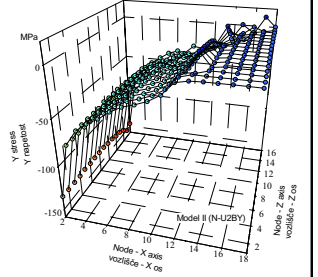
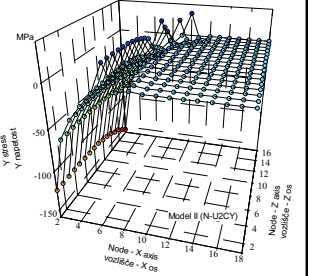
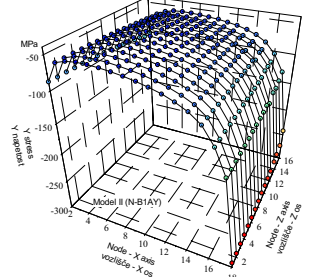
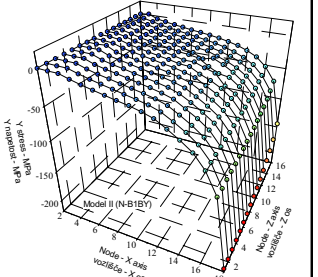
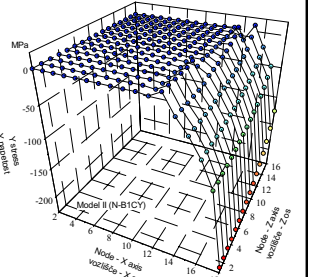
primer / case	A	B	C
\bar{p} (MPa)	100	40	20
Y napetosti na zgornji stični ploskvi / Y stresses on upper contact surface			
Y napetosti na spodnji stični ploskvi / Y stresses on lower contact surface			

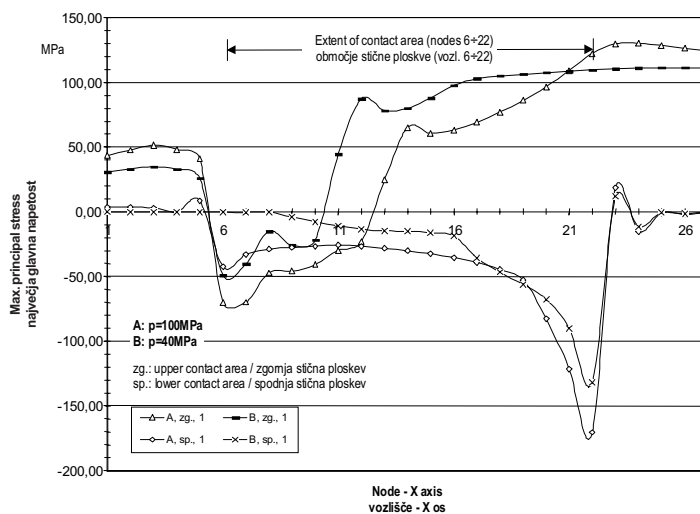

Sl. 5. Največje glavne napetosti na zg. in sp. stični ploskvi (stičnica 1 - vzdolž osi X)
Fig. 5. Maximum principal stresses on upper and lower contact surface (contact line 1 – along X axis)

Rezultati ovrednotenja vpliva spenjalnega tlaka na velikost največje glavne napetosti in lego kritične točke na preskušancu so zbrani v preglednici 3.

Ugotovitve na podlagi numerične analize z MKE

Na podlagi rezultatov numerične analize je mogoče sklepati, da velikost spenjalnega tlaka močno vpliva na velikost relativnih premikov med spenjalno kladico in preskušancem ter na porazdelitev napetosti v stiku, ki sta bistveno vplivni veličini pri pojavu

The results of the evaluation of the clamping pressure influence on the magnitude of the maximum principal stress and the position of the critical point on the specimen are shown in Table 3.

Ascertainments following from FEM analyses

On the basis of the results of the numerical analysis, it is possible to conclude that the magnitude of the clamping pressure strongly influences the size of the relative displacements between the clamping pad and the specimen. The magnitude of the clamping pressure also influences the stress distribution in the

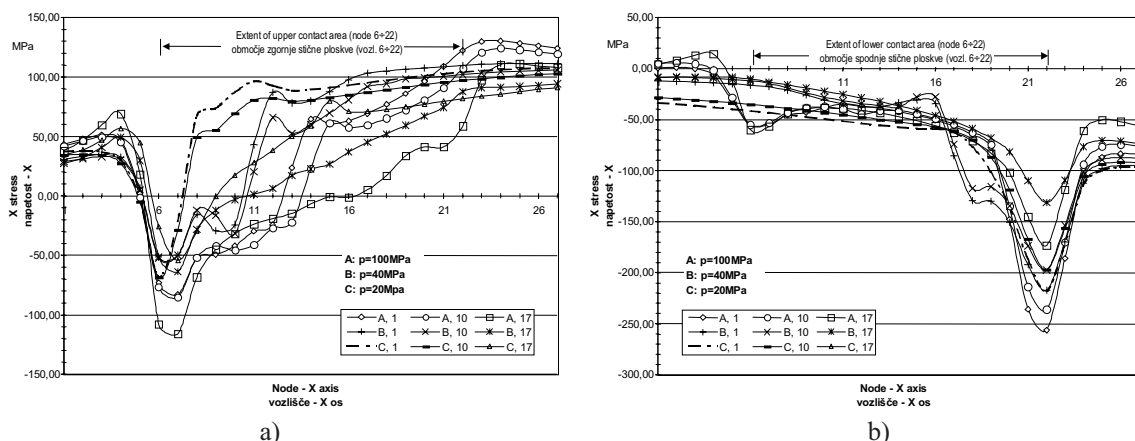

Sl. 6. Natezne (tlačne) napetosti (X) na zgornji (a) in spodnji (b) s. pl. (stičnice 1, 10 in 17 - v smeri osi X)
 Fig. 6. Normal stresses (X) on upper (a) and lower (b) contact surface (contact lines 1, 10 and 17 – along X axis)

Preglednica 3. Največje glavne napetosti v preskušancu pri največji upogibni obremenitvi
 Tab. 3. Maximum principal stresses in the specimen at maximum bending load

obremenilni primer loading case	\bar{p} MPa	največja glavna napetost max. principal stress MPa	odmik kritične točke od roba sp. kladice offset of the critical point from the edge of clamping pad mm
A	100	130,2	~ 0,5
B	40	111,3	~ 1,5
C	20	107,4	~ 2,0

zmanjšanja obratovalne trdnosti oziroma zmanjšanja zdržljivosti konstrukcijskega elementa.

Iz porazdelitve glavnih napetosti v preskušancu je moč oceniti območje, v katerem je največja verjetnost porušitve. Ocenjeni obseg te cone je do 2 mm pred zunanjim robom spenjalnih kladic. Ker je površinski tlak v stiku izrazito neenakomeren, je mogoče posledično pričakovati poškodbe na preskušancu tudi na mestih konic površinskih tlakov in relativno velikih zdrsov. Ti pogoji so izpolnjeni v glavnem le na zunanjem robu čeljusti.

Z numerično analizo so bila pridobljena tudi izhodišča za nastavitve parametrov (velikost relativnih pomikov, površinski tlak) pri analizah površinske hrapavosti in tornih koeficientov za parjena materiala ter podatki za izhodiščne nastavitve testnih pogojev na preskuševališču obratovalne trdnosti.

3 EKSPERIMENTALNO SIMULIRANJE OBRATOVALNE TRDNOSTI

Preskuševališče obratovalne trdnosti

Integrirano preskuševališče je zasnovano kot računalniško voden mehatronski sistem (sl. 7), ki dodatno omogoča trdnostno analizo dinamično obremenjenih upogibnih vpetij.

contact. Both of these factors strongly influence the decrease in the operational strength and the reduction in durability of a structural element.

From the main principal stress distribution it is possible to estimate the region which contains the highest probability of fracture. An estimation of the extent of this region, suggests that it stretches up to 2 mm outside the outer edge of the clamping pads. Owing to an exceptionally non-uniform distribution of the surface pressure, it is possible to anticipate damage in the specimen where the surface pressure peaks occur and in the region of maximum slip. These conditions are fulfilled, only on the outer edge of the clamping pads.

Starting points for the set-up of parameters (relative displacement magnitude, surface pressure) for analyses of surface roughness, and coefficients of friction for matched materials, and also data for initial testing conditions set-up on the testing facility for operational strength, were obtained by means of numerical analysis.

3 EXPERIMENTAL SIMULATION OF OPERATIONAL STRENGTH

Testing facility for analysis of operational strength

An integrated testing facility was designed as a computer controlled mechatronic system (Fig. 7), which additionally enables strength analysis of dynamically loaded bendings.

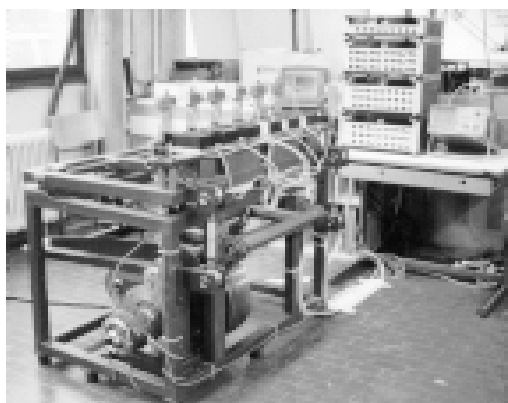
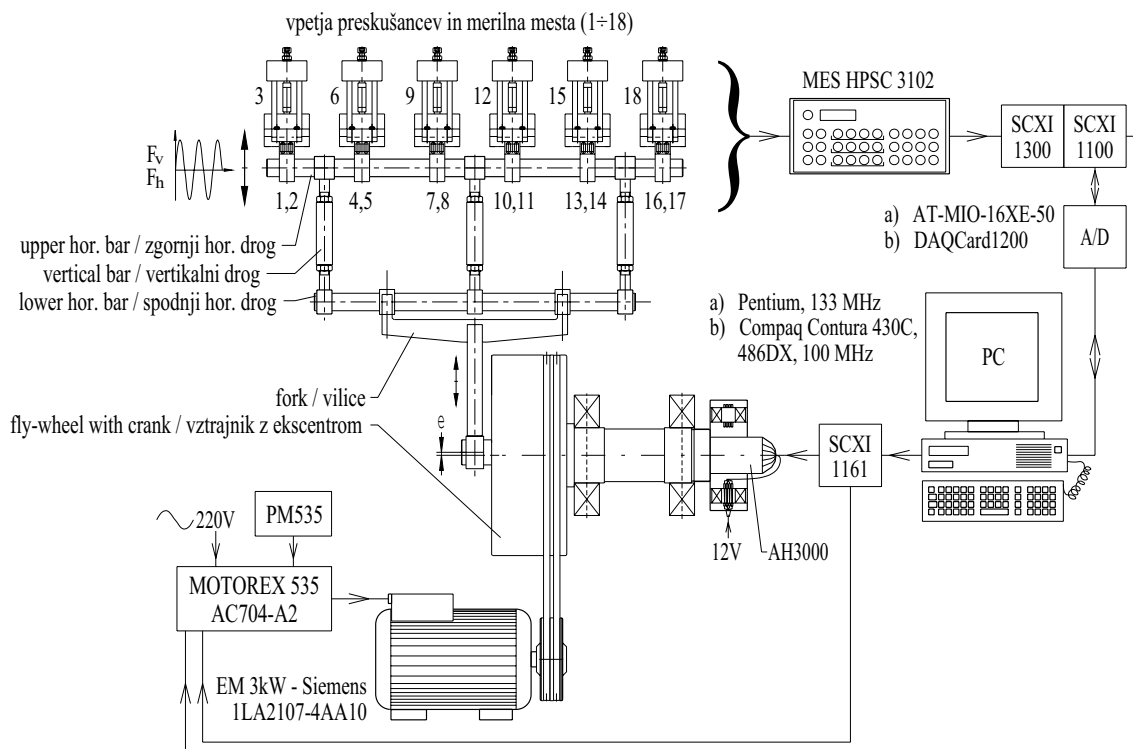

Sl. 7. Preskuševališče za analizo obratovalne trdnosti upogibnih vpetij v laboratoriju LAVEK
Fig. 7. Testing facility for analysis of operational strength of bending clamping in LAVEK laboratory

Vpliv spenjalnega tlaka na obratovalno trdnost simulirnega upogibnega vpetja preskušancev iz aluminijevih zlitin se ugotavlja s preskusi pri različnih nivojih in načinih obremenjevanja (Wöhlerjevi in blokovni preskusi) ter različnih vrednostih površinskih tlakov v stiku.

Obremenitveni nivoji oziroma največje amplitude napetosti so (za vse preskuse) izbrani glede na pričakovano življenjsko dobo, ki naj bo za Wöhlerjeve preskuse med 10^5 in 2×10^6 obremenitvenih ponovitev, za preskuse obratovalne trdnosti, ki se izvajajo po 8-stopenjskem (Gassnerjevem) programu, pa naj bo življenjska doba največ 2×10^7 ponovitev.

Na preskuševališču je mogoče hkrati preskušati največ šest preskušancev, vendar pri enakih upogibnih obremenitvah. Zasnova

The influence of clamping pressure on the operational strength of simulated bending clampings of an Al-alloy specimen is established by tests at various loading levels and different loading programmes (Wöhler and block tests) and also at various surface pressures in the contact.

Loading levels or maximum stress amplitudes are (for all tests) selected with respect to an expected fatigue life which should be between 10^5 and 2×10^6 loading cycles for Wöhler tests. For durability tests, which are performed according to the 8-stage (Gassner) loading programme, the fatigue life should not be greater than 2×10^7 cycles.

On the testing facility it is possible to test up to 6 specimens simultaneously, but under identical bending loading conditions. The design of the facility

preskuševališča omogoča sinusno obremenjevanje ter nemoteno delovanje tudi po poružitvi večjega dela preskušancev. Preskusi se izvajajo pri nadzoru pomika gibljivega krajišča preskušanca, upogibne napetosti v preskušancu pa so v neposredni zvezi s pomikom krajišča.

Pojav razpoke se kaže v zmanjšanju amplitude napetosti, ki je merilo za ugotavljanje dobe trajanja preskušanca. Frekvenčno območje obremenjevanja je od 1 Hz do 15 Hz, največja dovoljena amplituda upogibne sile pa 1000 N.

Analiza rezultatov preskusov obratovalne trdnosti

Analiza obratovalne trdnosti je opravljena na podlagi časovnega poteka obremenitve, ki je za vsak prekušanec posebej natančno poznan (stalno zapisovanje stanja v primernih časovnih korakih na disk). Primera dobljenih časovnih potekov obremenitve za Wöhlerjev in 8-stopenjski Gassnerjev preskus sta prikazana na sliki 8. Morebitna odstopanja eksperimentalne oblike obremenitvenih kolektivov od idealne (ciljne) se upoštevajo z uporabo hipoteze o akumulaciji poškodbe. Dobljene življenjske dobe izkazujejo določen raztros, z dodatnimi analizami pa se izkaže, da je njihova porazdelitev normalna (Gaussova).

Rezultati preskusov so prikazani v obliki Wöhlerjevih krivulj oziroma krivulj zdržljivosti, z vrisanimi mejami zanesljivosti (sl. 9).

enables sinusoidal loading and undisturbed operation after fracture of the greater part of the specimen. Tests are carried out under conditions of controlled displacement of the movable end of the specimen, but bending stresses in the specimen are in direct relation to the displacement of the movable end.

The occurrence of a crack results in a decrease of the stress amplitude, which is the measure for assessment of the fatigue life of the specimen. The loading frequency ranges from 1 Hz to 15 Hz, the maximum allowed bending force is 1000 N.

Analysis of operational strength tests results

The analysis of the operational strength is carried out on the basis of the loading history, which is precisely known for each specimen (permanent recording of the loading state in suitable time intervals to the disk). Examples of obtained loading histories for the Wöhler and 8-stage block (Gassner) test are presented in Figure 8. Possible deviations of the shape of the experimental loading spectra from ideal (target) shape are considered by damage accumulation hypothesis. The obtained fatigue lives show a degree of scatter, using additional analyses it can be proved that their distribution is normal (Gaussian).

Test results are presented in the form of Wöhler or durability curves with traced probability limits (Fig. 9).

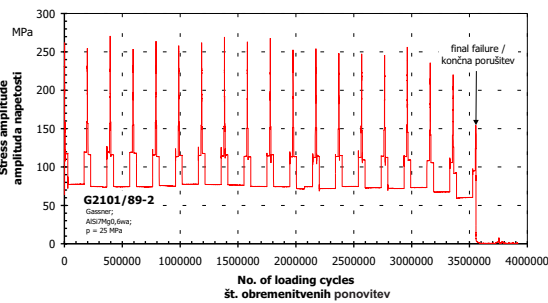
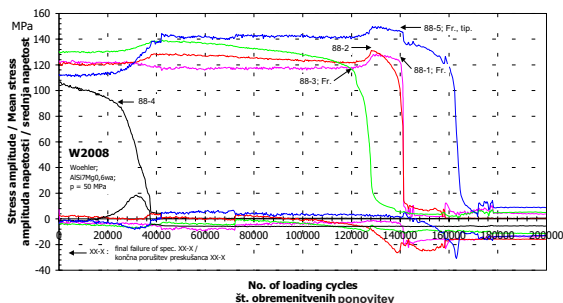

Sl. 8. Časovni potek obremenitve za Wöhlerjev (enostopenjski) in 8-stopenjski Gassnerjev preskus
Fig. 8. Loading history for Wöhler (single-stage) and 8-stage (Gassner) testing

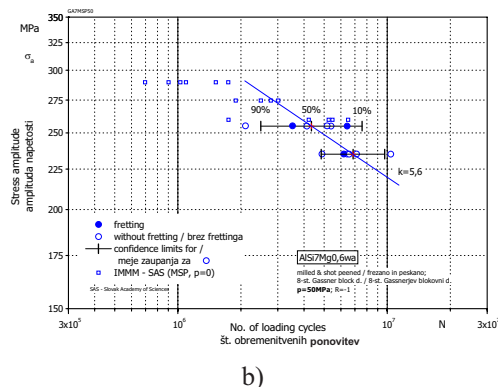
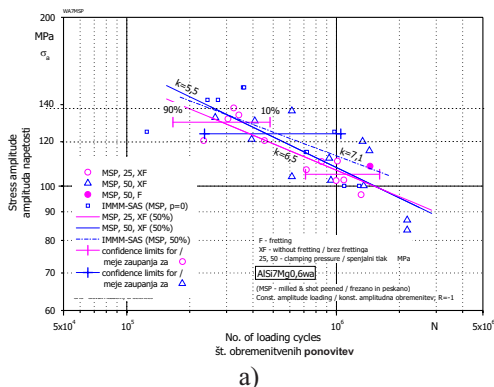

Sl. 9. Wöhlerjeve krivulje (a) in krivulje zdržljivosti (b) za material AISi7Mg0,6wa
Fig. 9. Wöhler (a) and durability (b) curves for AISi7Mg0,6wa material

Poleg določitve dobe trajanja je na preskušancih opravljena tudi analiza lomne cone, ki pokaže da se v primeru dinamično obremenjenega upogibnega vpetja aluminijastih preskušancev pojavita najmanj dva različna načina utrujanja oziroma nastanka in širjenja razpoke.

Tako je mogoče opaziti, da se je del preskušancev zlomil na zunanjem robu spenjalnih kladic oziroma, da sega razpoka do zunanjega roba cone vpetja (sl. 10-a), del preskušancev je počil v coni od 1 do 2 mm pred zunanjim robom (sl. 10-b), izjemoma pa je prišlo do poškodbe drugeje. Delež posameznih primerov lokacij lomnih con je odvisen tako od materiala in površinske obdelave, kakor tudi od načina preskušanja.

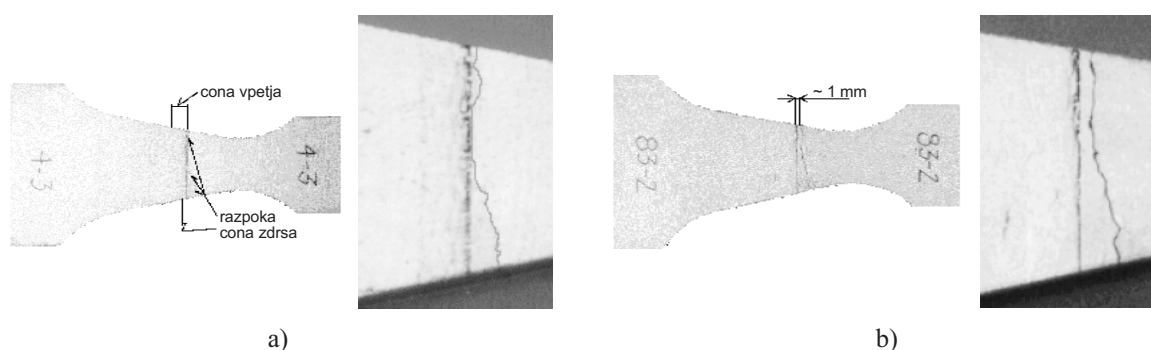

Sl. 10. Značilne poškodbe na preskušancih (AlSi7Mg0,6wa)
Fig. 10. Characteristic damage on specimen (AlSi7Mg0,6wa)

4 SKLEP

Pri preskusih obratovalne trdnosti se je izkazalo, da se zaradi utrujanja obravnavanega upogibnega vpetja pojavljata dva različna tipa poškodbe preskušanca. Prvi tip poškodbe, ki se pojavi na robu spenjalne kladice, je na podlagi analize površinskih poškodb in numerično dobljenih ocen relativnih premikov mogoče pojasniti kot posledico drsnega utrujanja. Poškodba v coni 1 do 2 mm pred zunanjim robom spenjalne kladice pa se pojavi na mestu največjih glavnih napetosti, ki so odločilne za širjenje začetne razpoke in končno porušitev. Na podlagi rezultatov preskusov je mogoče sklepati, da je tip utrujenostne poškodbe v upogibnem vpetju odvisen od velikosti spenjalnega tlaka, vrste materiala in površinske obdelave ter nenazadnje tudi od načina obremenjevanja, t.j. od vrste obremenitve in frekvence obremenjevanja. Rezultati preskusov se v pretežni meri ujemajo z ugotovitvami in napovedmi analiz modela vpetja z MKE.

Predlagani postopek ugotavljanja življenjske dobe upogibnega vpetja se izkaže uporaben in učinkovit, saj je iz zgodovine obremenitev mogoče odkriti nastanek razpoke in določiti faze napredovanja utrujenostne poškodbe, kar je temelj za pravilno določitev življenjske dobe preskušanca in krivulj zdržljivosti. Izvedeno računalniško krmiljenje

4 CONCLUSION

Using operational strength tests, it was shown that two different types of specimen failure occurred as a result of the fatigue of the treated bending clamping. The first type, which occurs at the edge of the clamping pad can be explained in terms of surface damage analysis and numerically acquired estimations of the relative displacement, as a result of fretting fatigue. The fracture in the zone 1 to 2 mm in front of the outer edge of the clamping pad occurs at the point of maximum principal stresses, which are decisive for initial crack propagation and final fracture. On the basis of the test results, it is possible to conclude that the type of fatigue damage in the bending clamping depends on the magnitude of the clamping pressure, the type of material and the surface treatment as well as on the manner of testing i.e. on the shape of the loading spectra and loading frequency. The obtained test results are mainly in agreement with the findings and predictions of the FEM analyses of the clamping model.

The proposed procedure of fatigue life assessment of the bending clamping is proved as applicable and efficient, because it is possible to detect crack initiation and to determine the phases of fatigue damage progress, which is the basis for accurate determination of the fatigue life of the

omogoča simuliranje raznovrstnih oblik obremenitvenih kolektivov, kar pomeni, da je preskuševališče uporabno ne le za Wöhlerjeve oziroma Gassnerjeve preskuse, temveč tudi za laboratorijsko preskušanje zdržljivosti malodane poljubno obremenjenih konstrukcijskih elementov.

specimen and durability curves. The realised computer control enables simulation of various shapes of loading spectra, which indicates that the testing facility is not only applicable to Wöhler or Gassner tests but also to laboratory testing of endurance of a wide variety of loaded structure elements.

5 LITERATURA 5 REFERENCES

- [1] ASM International Handbook Committee: Fatigue and fracture (1996), *ASM Handbook-Volume 19*, 1st Ed., Materials Park, OH.
- [2] Buxbaum, O. (1986) Betriebsfestigkeit. *Verlag Stahleisen mbH*, Düsseldorf.
- [3] Čižman, J., Klemenc, J., M. Fajdiga (1997) Simulation of actual fatigue at aluminium components under conditions of fretting and plane-reverse bending. *Proceedings of the 2nd Congress of Croatian Society of Mechanics*, Supetar na Braču.
- [4] Faanes, S., U.S. Fernando (1994) Influence of contact loading on fretting fatigue behaviour. *Fatigue Fract. Engng Mater. Struct.* 17, No. 8, s. 939-947.
- [5] Fajdiga, M. (1999) Improvement of strength properties at aluminium components by manufacturing procedures. *University of Ljubljana*, 3rd Report.
- [6] Goss, G. L., D.W. Hoepfner (1974) Normal load effects in fretting fatigue of titanium and aluminium alloys. *Wear* 27, 153-159.
- [7] Grubišić, V., U. Wessling (1997) Improvement of strength properties at aluminium components by manufacturing procedures. *Fraunhofer-Institut für Betriebsfestigkeit (LBF)*, Darmstadt, 24-Months Progress Report.
- [8] Haibach, E. (1989) Betriebsfestigkeit – Verfahren und Daten zur Bauteilberechnung. *VDI-Verlag GmbH*, Düsseldorf.
- [9] Nowell, D., D.A. Hills (1987) Mechanics of fretting fatigue tests. *Int. J. Mech. Sci.* 29, No. 5, 355-365.
- [10] Pukl, B., F. Vodopivec (1997) The fretting behaviour of AlSi7Mg-T6. *Wear* 212, 173-182.
- [11] Waterhouse, R. B. (1992) Fretting fatigue. *International Materials Reviews* 37, No. 2, 77-97.

Naslov avtorjev: mag. Jure Čižman
prof. dr. Matija Fajdiga
Fakulteta za strojništvo
Univerze v Ljubljani
Aškerčeva 6
1000 Ljubljana

Authors' Address: Mag. Jure Čižman
Prof. Dr. Matija Fajdiga
Faculty of Mechanical Engineering
University of Ljubljana
Aškerčeva 6
1000 Ljubljana, Slovenia

Prejeto: 20.10.1999
Received:

Sprejeto: 3.12.1999
Accepted: