

Practical Implementation of Load Sharing and Anti Skew Controllers for Wide Span Gantry Crane Drives

Nebojša Mitrović^{1,*} - Vojkan Kostić¹ - Milutin Petronijević¹ - Borislav Jeftenić²

¹University of Niš, Faculty of Electronic Engineering, Serbia

²University of Belgrade, Faculty of Electrical Engineering, Serbia

In this paper controlled electrical drives for Rail Mounted Wide Span Gantry Cranes are analyzed. The modern solution considers the application of frequency converters for all drives. Special attention is paid to multi-motor drives of horizontal movement in the sense of load distribution. Although it can be considered that motors are rigid coupled by mechanical construction, they do not need an equal load torque. Presented algorithm provides load sharing proportional to the rated motor power on the simple and practically applicable method on the basis of estimated torques by frequency converters, and controller realized in PLC. For wide span gantry drives efficient method for skew elimination is presented and simultaneous load sharing between the motors is done. The algorithms are experimentally verified on several places in industry and characteristic results are shown in this paper.

©2010 Journal of Mechanical Engineering. All rights reserved.

Keywords: gantry crane, multi motor drive, frequency converter, load sharing, skew controller

0 INTRODUCTION

Crane application is frequently used for handling heavy loads in different industry branches: metallurgy, paper and cement industry. Stationary or mobile units can be installed outdoors or indoors. Some industries, for example port containers application or open storage bins, require wide span gantry cranes. In outdoor applications, the influence of the wind on the behavior of the drive may be considerable [1]. Wind and skew can significantly influence a safe operation of the crane. This will certainly dispose the type design of the crane (lattice or box type design) from a mechanical aspect as well as the selection, size and control of crane electrical drives.

Electrical technology for crane control has undergone a significant change during the last few decades. The shift from Ward Leonard system to DC drive technology and the advent of powerful Insulated Gate Bipolar Transistors (IGBTs) during the 1990s enabled the introduction of the AC drive [2] and [3]. Conventional AC operated crane drives use slip ring induction motor whose rotor windings are connected to power resistance in 4 to 5 steps by power contactors. Reversing is done by changing the phase sequence of the stator supply through line contactors. Braking is achieved by plugging.

The main disadvantage is that the actual speed depends on the load. An electronic control system has recently been added to continuously control rotor resistor value. Nowadays, these systems are replaced by frequency converters supplied squirrel-cage induction motors for all types of motion [3]. Control concept based on application of Programmable Logic Controllers (PLCs) and industrial communication networks (Field-buses) are a standard solution which is used in complex applications [4].

A Rail Mounted Gantry Crane is typically used for moving containers, loading trucks or material storage. This crane type usually consists of three separate motions for transporting material. The first motion is the hoist, which raises and lowers the material. The second is the trolley, which allows the hoist to be positioned directly above the material for placement. The third is the gantry, which allows the entire crane to be moved along the working area. Very often, in industrial applications additional drives as auxiliary hoist, power cable reel and conveyer belt are needed. Therefore, generally, a crane is complex machinery. Depending on the crane capacity each of the mentioned drives, can be realized as multi-motor. The term multi-motor drive is used to describe all the drives in a technological process.

*Corr. Author's Address: Faculty of Electronic Engineering, A. Medvedeva 14, 18000 Niš, Republic of Serbia, nebojsa.mitrovic@elfak.ni.ac.rs



Fig. 1. *Accidental collapse of the gantry crane metal structures*

If the controlled operation of the drives is required by the process based on the controlled speed of the individual drives, the expression controlled multi-motor drives is adequate. For many of such drives, the mechanical coupling on the load side is typical [5] to [7]. In applications with cranes, coupling of the individual motors is realized by the mechanical transmission device, and it is usually technologically unbreakable.

The reason for writing the paper is wide span gantry crane accident in a sugar factory, as consequence of skewing, Fig. 1. Authors of this paper were given an assignment to design all electrical drives on the crane and in particular, to solve the problem of gantry drives as the cause of breakdown. For these reasons characteristic drives of crane movement are considered. In the first part of the paper, control topologies for multi-motor load sharing are presented.

In the second part of the paper, an application of wide span gantry crane drives which serve for reloading the sugar beet is shown. The solution for load distribution in multi-motor drive, as well as the mode of skew elimination for gantry drive is described. The suggested solution is confirmed with experimental results.

1 POSSIBLE LOAD SHARING CONFIGURATIONS OVERVIEW

Controlled drives are usually fed from the power converter, which is also true for controlled multi-motor drives. The kind, the type and the number of converters used depend on the type of motors, their power ratings, and of the kind of the multi-motor drive. The control and regulation also depend on the type of the multi-motor drive,

but also on the type of the converter selected, therefore the selection of the converter and the controller for these drives must be analyzed together. Regarding the power supply of the motor, the following cases are possible [5]:

- multiple motors fed by a single converter (multiple motors-single converter);
- motors that are controlled by separate converters (multiple motors-multiple converters).

In crane applications multi-motor drives are used very often and a proportional share of power between motors is required. Load sharing is a term used to describe a system where multiple converters and motors are coupled and used to run one mechanical load [6]. In the strictest sense, load-sharing means that the amount of torque applied to the load from each motor is prescribed and carried out by each converter and motor set. Therefore, multiple motors and converters powering the same process must contribute its proportional share of power to the driven load.

Multiple motors that are run from a single converter do not load share because torque control of individual motors is not possible. The load distribution, in that case, is influenced only by the correct selection of the torque-speed mechanical characteristic. For the squirrel-cage induction motors, there is no economical method for the adjustment of the mechanical characteristic of the ready-made motors, but this has to be done during the selection. For the slipping induction motor, the mechanical characteristic can be adjusted afterwards, with the inclusion of the rotor resistors. Motors that are controlled by separate converters without any

interconnection also do not share the load. The lack of interconnection defeats any possible comparison and error signal generation that is required to compensate for the differences in the load that is applied to any single drive and motor set.

Control topologies for load sharing consider the presence of interconnection, i.e. information knowledge about load (motor current or torque). There are three categories of load sharing techniques: common speed reference, torque follower and speed trim follower.

The common speed reference is the simplest the most precise and the less flexible form of load sharing to set up, Fig. 2. The precision of this control depends on the drives control algorithm, the motor characteristics and the type of load to be controlled.

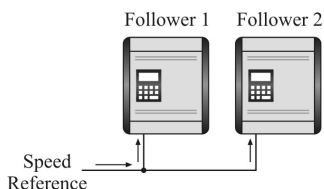

Fig. 2. Common speed reference configuration

The torque follower type of load sharing requires the frequency converter to have the capability of operation in "torque mode", Fig. 3. If speed regulation is required, one of the converters ("master") may be in "speed mode". In speed mode controller provides a torque command at output which can be distributed to the other converters ("slaves" or "torque followers"). The second converter operates in torque regulation mode with the torque reference of the master as command. This torque signal may be scaled to divide load sharing in any desired ratio.

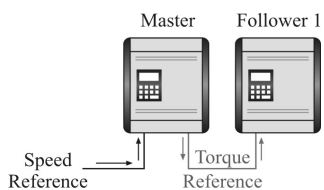

Fig. 3. Torque follower configuration

In speed trim follower configuration, Fig. 4, all converters are operated in speed regulation

mode and receive the same speed reference. The torque reference of the master is sent to the follower converters. Each follower converter compares its own torque reference with that of the master, Fig. 4a. The output of the comparator is an error signal that trims the speed of the follower. Alternative configuration cascades the torque reference comparison, Fig. 4b. The first follower compares the master to its internal value. The second follower compares the foregoing follower to its internal value etc.

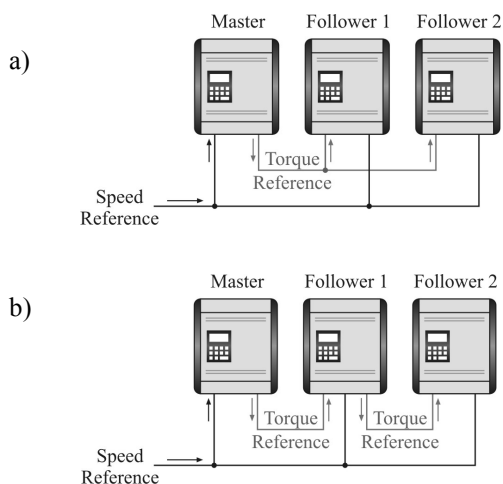

Fig. 4. Speed trim follower configuration

2 CASE STUDY - PRACTICAL IMPLEMENTATION OF WIDE SPAN GANTRY CRANE

2.1 Load Sharing

The experimental behavior analysis of some drives is considered in a crane with wide span, which serves for continuous transport of sugar beet from the reception position to the factory storage in a sugar factory.

The crane with the following details has been taken for experimentation with adjustable frequency induction motor drives:

- Handling capacity: 500 t/h;
- Gantry span: 64.5 m;
- Hoist height: 18 m;
- Working conditions: outdoor.

Gantry crane for sugar beet storage consists of the following main functional parts:

1. Gantry drive (16 m/min) with four

- induction motors of 5.5 kW, two per leg.
- 2. System conveyor belts (2 m/s) with "battered" (30 kW), horizontal (30 kW) and "butterfly" conveyor (11 kW).
- 3. Trolley drive (12 m/min) with four motors of 1.1 kW.
- 4. "Butterfly" hoist (3 kW).
- 5. Motor driven cable reel (1.1 kW).
- 6. Decentralized crane drive control system with appropriate PLC, Profibus communication between converters and other intelligent devices (for example: encoders, operator panels etc.), Fig 5.

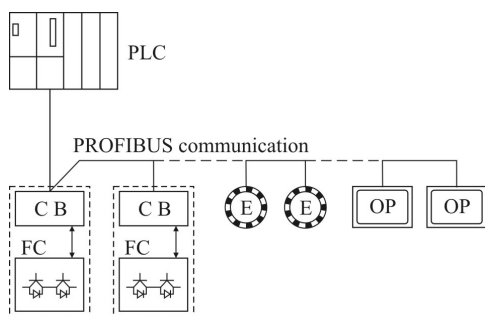

Fig. 5. Decentralized crane drive control

In Fig. 6 gantry crane with indicated drives is shown. All motors are three phase fed by frequency converters.

Certainly, the gantry drive is the most complicated, for the following reasons:

- that is multi motor drive which consists of two motors on each side;
- the span is wide;
- construction is lattice, therefore it is elastic;
- plant is located outdoor so the influence of the wind may be considerable;
- the length of runway rail path is 300 m.

Basic requirements set in front of this drive are: equal load distribution between motors located on the same side, as well as skew elimination between the fixed and free gantry leg.

Although the motors have the same power, there are few necessary reasons to do the load distribution: different wheel diameter, unequal adhesion, geometrical imperfection of the construction, slipping of the pinion wheel due to wet or frozen rails. Load distribution is resolved by using speed trim load sharing configuration, as shown in Fig. 4b. Load distribution controller is realized by PLC.

In Fig. 7 the principle block scheme for load distribution between two rail coupled induction motors (IM_1 and IM_2) fed by frequency converters (FC1 and FC2) is shown. The starting point in designing load sharing controller is that the less loaded motor should accelerate in order to take over the part of load from the more loaded motor. Information about the load can be obtained in different ways. The easiest one is by motor current. Modern converters used in drives, enable to obtain information about the motor torque in percentage in relation to rated torque.

As it can be observed in Fig. 7, the speed reference of only one motor (n_2^*) is updated in relation to the main speed reference ($n_1^* = n^*$). Reference correction Δn^* is proportional to the difference of estimated electromagnetic torque ($\Delta T_e = T_{e1} - \Delta T_{e2}$). A proportional gain of load sharing regulators K_{LS} can be calculated:

$$K_{LS} = \frac{\Delta n^* d}{\Delta T_{eg}} \quad (1)$$

where n_d^* is the desired reference speed correction in relation to main speed reference for given electromagnetic torque differences ΔT_{eg} .



Fig. 6. Gantry crane with indicated drives

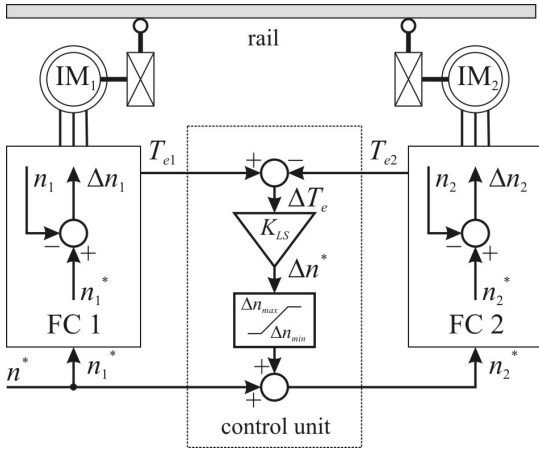

Fig. 7. The principle of load sharing based on estimated torque

In order to ensure the stable operation of the motors during the large external disturbances, especially at low speed when estimation of electromagnetic torque in speed sensorless drives loses on accuracy, it is necessary to limit the correction value Δn^* , as shown in Fig. 7.

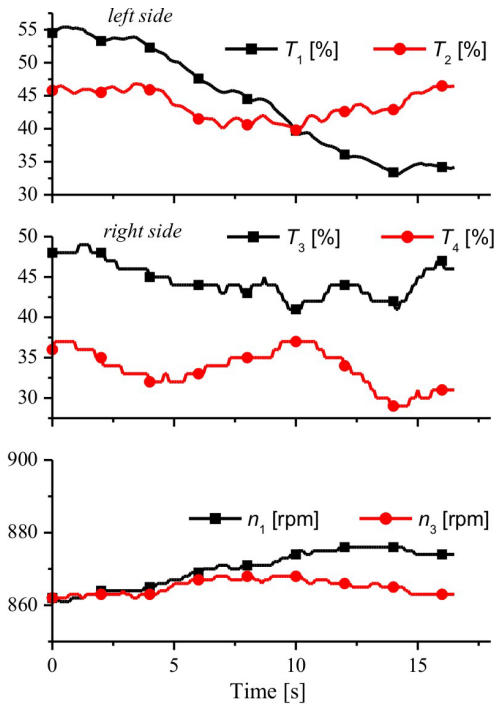

Fig. 8. Motors torque and speed without load sharing

For the purpose of suggested algorithm verification the trolley load sharing is analyzed.

Because of the short distance between the left and the right side, the skew may be neglected. Trolley drive consists of four motors, two on each side (IM_1 - IM_2 on left and IM_3 - IM_4 on right side). Frequency converters are set on speed sensorless vector control mode. Motors have the common reference speed. In Fig. 8 motors torque without load distribution is shown. At reference speed, in steady state, we can see that even the motors have the same rated power, load torques are different. Estimated motor torque is not applied in control algorithm. The speed between the left and the right side is different because it depends on the motor characteristics and the load, as shown in Fig. 8.

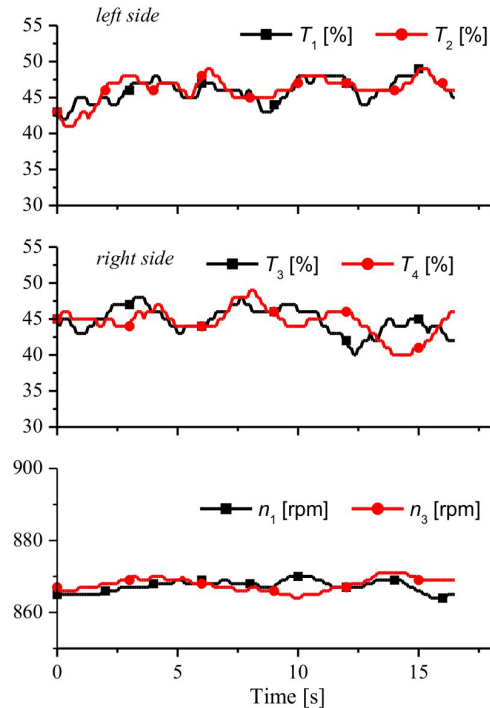

Fig. 9. Motors torque and speed with load sharing

The effect of load sharing is shown in Fig. 9. Approximately equal motor torque on the same leg can easily be seen. The system used enables the speed of every motor to be regulated, and the load difference to be controlled. In this way, the load difference is being maintained on the desired accuracy.

The type of controller used is determined by the purpose of motor drive and by required accuracy of the load distribution. It is common to

use either PI (with both, proportional and integral term) or simply P (pure proportional) type of controller. In our case only the proportional controller with $K_{LS}=1$ p.u. is used. The output from the load controller is limited to only several percentages of maximum speed reference (in our example $\Delta n_{\min-\max}=2\%$). That is quite enough to provide necessary load regulation and not to "break" the drive speed regulation by an effect too big on the speed reference. This solution can be applied to all kinds of multi motor drives on cranes.

2.2 Gantry Drives and Skew Elimination

Rail mounted gantry cranes frequently skew due to poor rail conditions, uneven wheel wear, wheel slippage or unequal load conditions when the trolley is operating at one end of the crane bridge. Skewing of the crane can cause excessive wheel wear and stress, especially to the wheel flanges. It can also produce horizontal forces at the right angles to the rail, which can result in unusual stresses to the crane runway beams and building structure. This often results in differing diameters of drive wheels, which subsequently cause the crane to skew.

In the analyzed example, the whole drive of crane movement consists of fixed and free gantry legs. The distance between fixed and free leg is 64.5 m. The length of the runway rail path is 300 m. Legs have drives on both of their ends with three phase induction motor power of 5.5 kW. Therefore, for the drive of the whole gantry four motors are used. Maximum speed of movement is 16 m/min. Movement is allowed if the wind speed is less than 25 m/s. Construction of the gantry is lattice, to decrease the influence of wind, and for the given span elasticity is expressed. Loads of fixed and free legs are different, partly because of the asymmetry of the gantry, but mostly because of the trolley which is moving along the gantry with loaded belts. Calculated critical skew of gantry is 1 m, and adopted maximal allowed skew is 50 cm.

Skew elimination is realized by suitable PLC, two absolute encoders, two proximity sensors (with six pairs of markers 50 cm length) and four frequency converters for motor supply of gantry drives, as shown in Fig. 10. On each leg one of the converters is the master and the other

one is the slave. The difference of their references is a consequence of load sharing between motors on that leg. The principle of load sharing on the same leg is described in previous subsection and shown in Fig. 7.

For the cause of skew tracking, two absolute encoders are used (one for each leg). The encoders are installed on a special wheel which is not tractive (a so called free wheel), in the cause to avoid slipping. Encoders measure the traveled path, and the information is forwarded to the regulation subsystem which is realized in PLC. The master converter on the fixed leg is chosen to be the master converter for the gantry drive, while in this case, the master converter on free leg is the slave for gantry, Fig. 10.

On the basis of travelled paths difference, the skew controller generates the total reference speed component, as the consequence of skew. The control scheme for skew elimination between the master and slave motor of gantry drive is shown in Fig. 11. Design of the skew controller is based on a simple idea that the motor at the lagging side of gantry should be accelerated, in order to eliminate the skew. As shown in Fig. 11, the speed reference of only one motor (n_2^*) is updated, in relation to the main speed reference (n_1^*). Reference correction Δn^* is proportional to the difference of absolute encoder position ΔE . Controller gain K_{SC} can be calculated by (2):

$$K_{SC} = \frac{\Delta n^* d}{\Delta E_g} \quad (2)$$

where Δn^* is the desired reference speed correction in relation to the main speed reference for given encoder position differences ΔE_g .

In order to ensure a stable operation of the motors during the large external disturbances, especially at low speed when estimation of electromagnetic torque in speed sensorless drives loses accuracy, it is necessary to limit the correction value Δn^* . Skew is achieved as the difference of position between two encoders with respect of the correction from the external disturbance compensator. External disturbances compensator (EDC) respects all external influences on the position difference of two encoders: the difference in the wheel diameter, wheel and joint encoders slipping.

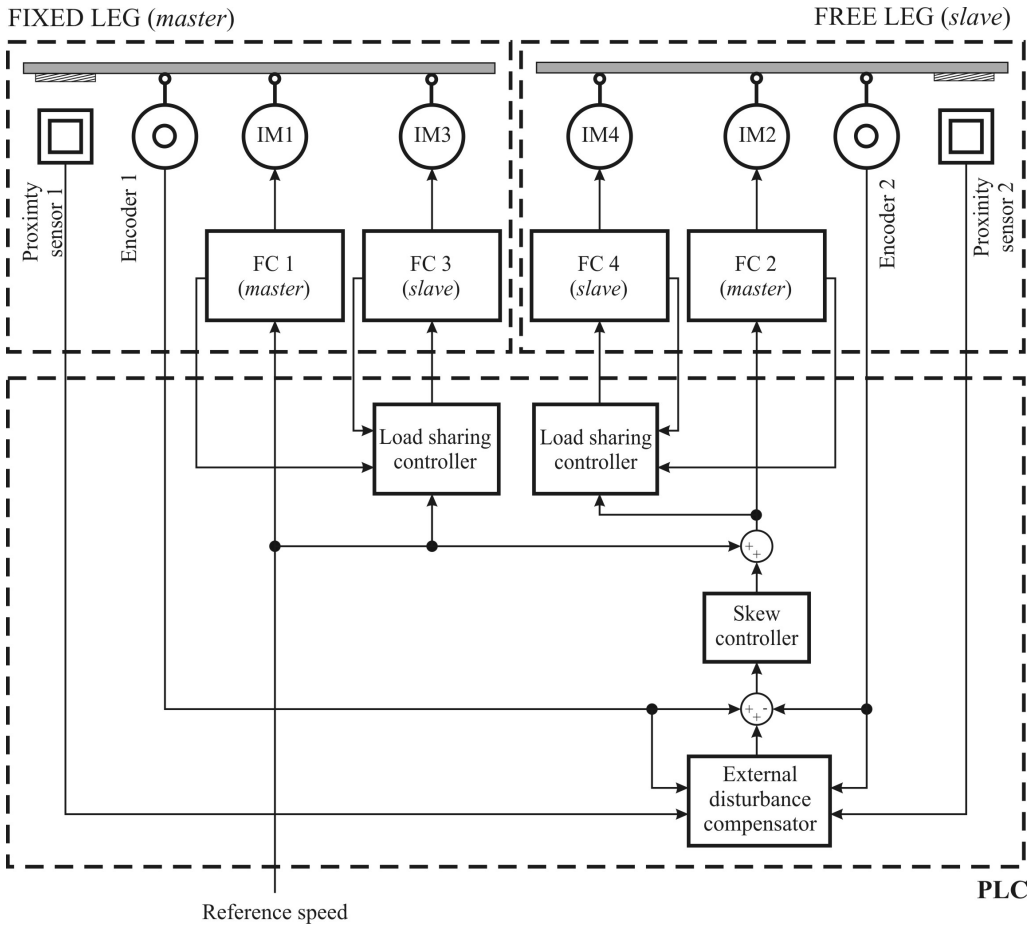

Fig. 10. Block scheme of gantry drive

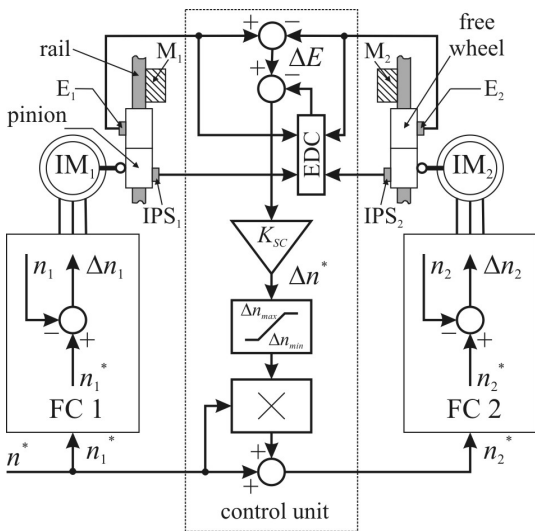

Fig. 11. The principle block diagram of skew controller

The biggest external disturbance, the slipping of driving wheels, is eliminated by mounting encoders on free wheels. Position "a" in Fig. 12, represents skew (s) as the distance between the reference point and normal on movement direction. Pairs of markers (M) and proximity sensors (IPS) are needed for the realization of the disturbance compensator. Proximity sensors are fitted on legs, while the markers are mounted and equidistantly disposed along the rails. During the movement of the crane, proximity sensors serve to detect the presence of the markers and to register the moment when fixed (or free) leg passes above markers. Generally, crossing over the markers of the fixed and free leg is not simultaneous. By absolute encoders the trajectory difference is measured up until the moment when both legs are

positioned on the markers, as shown in Fig. 12 position “b”. In fact, this difference is the real skew of the crane, determined at each crossing over the markers, and is the output of the external disturbance compensator. If the difference is greater than the length of markers, the crane skew is more than allowed. For this reason it is required that the length of markers matches the allowed skew of the crane. The number of markers that should be mounted along the runway is estimated on the basis of the static speed accuracy of the drive (especially for speed sensorless drives) and the maximum deviation of wheel diameter (geometrical imperfection of the construction). In our case, the distance between markers is 50 m.

The distance between successive markers (l_{ms}), for adopted length of marker l_m , can be calculated by expression:

$$l_{ms} \leq \frac{l_m}{\frac{e\%}{100}} \quad (3)$$

where $e\%$ is the maximum expected linear speed difference between the legs in percentage. The number of marker pairs n_m for the length of runway rail path l can be estimated by:

$$n_m \geq \frac{l}{l_{ms} + l_m} \quad (4)$$

Per unit upper and lower limiter saturation value in Fig. 11, $\Delta n_{\min-\max}$, is adjusted by:

$$\Delta n_{\min-\max} = \pm \frac{1}{n_{\max}^*} \cdot I_p \cdot \frac{l_m}{\pi \cdot D_p} \cdot \frac{1}{t_m} \quad (5)$$

where is:

n_{\max}^* - maximum speed reference [rpm],

I_p - pinion wheel gearbox ratio,

D_p - diameter of pinion wheel [m],

t_m - max. allowed skew correction desired time [min].

By assumption $\Delta n_d^* = |\Delta n_{\min-\max}|$ and ΔE_g as the number of encoder pulses, which represent the length of marker, controller proportional gain K_{SC} is easily obtained by Eq. (2).

In Fig. 13, the behavior of gantry drives without skew controller is shown. Therefore, in this case load sharing regulators for fixed and free gantry leg are included. The initial crane skew is about 10 cm. From the load sharing aspect,

motors torque, and torque difference on the same side should be observed. The estimated motors torque are obtained from the frequency converter. Mechanical computation, performed by SAP software package, shows that the skew influence is manifested differently on the motor torque on fixed and free leg. Skew influences on the motor torque are shown in Table 1. Increasing tendency of skew is noticed, Fig. 13. In this case, skew is value that cannot be controlled.

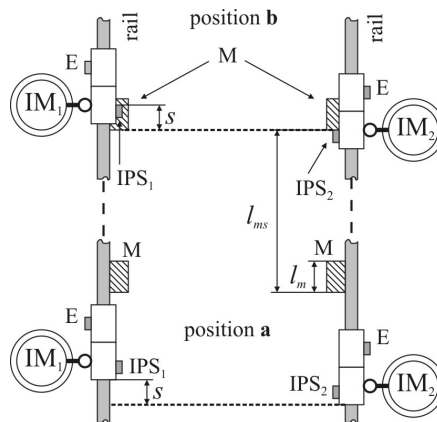

Fig. 12. The principle of EDC

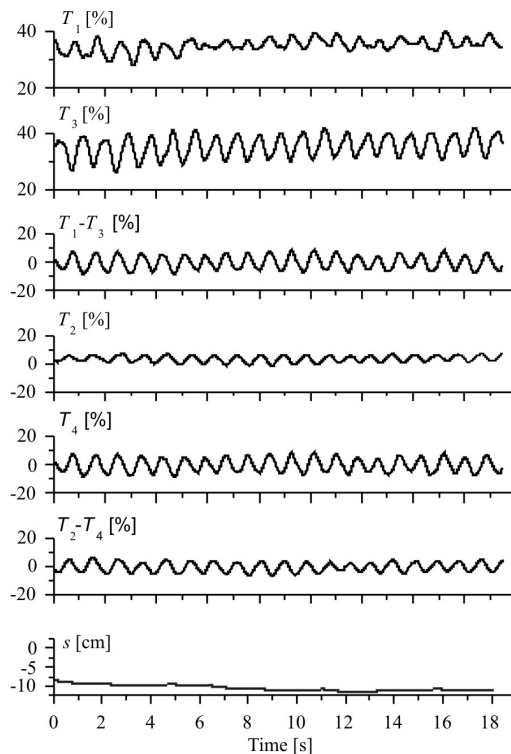

Fig. 13. Behavior of gantry drives without skew controller

Table 1. *Torques during the skew*

Skew [m]	Free leg torque [Nm]	Fixed lag torque [Nm]
0.1832	5.33	152.55
0.3664	10.66	305.102
0.549	15.99	457.65
0.732	21.32	610.2
0.915	26.65	762.75

Fig. 13 confirms the data given in Table 1. During crane skew, motors (IM₁ and IM₃) on fixed leg are more loaded than the motors (IM₂ and IM₄) on the free leg. Also, the effects of the load sharing controller can be noticed because the motors on the same leg approximately share loads, i.e. torque difference oscillate about zero value. The amplitude oscillation depends on load sharing gain controller and its limiter settings, as in the previous subsection explained, Fig. 7.

Fig. 14 shows experimental results including the skew controller. Gantry drive relevant parameter and controller set-up values are shown in Table 2. Three working sections are noticeable: i) crane acceleration, ii) steady state operation and iii) crane deceleration. The observed variables are: master motor speed, estimated speed difference between master motor on fixed leg and master motor on free leg, estimated torque differences between motors on the same leg and actually skew.

 Table 2. *Parameter and controller set-up values*

Parameter values			
n_{\max}^*	1455 rpm	$E_{p,rev}$	4096 puls.
I_p	394.7368	D_p	0.5 m
I_{fw}	15.6466	D_{fw}	0.5 m
l	300 m	l_m	50 cm
t_m	1 min	$e_{\%}$	1 %
Load sharing controller		Skew controller	
K_{LS}	1	K_{SC}	1/236230
$\Delta n_{\min-\max}$	± 0.02	$\Delta n_{\min-\max}$	± 0.1
$E_{p,rev}$ - encoder pulses per rev. [pulses/rev]			
I_{fw} - free wheel gearbox ratio			
D_{fw} - diameter of free wheel [m]			

In the first section, during crane acceleration due to different load between the fixed and free leg (trolley position, conveyor belts ballast) skew in transient is noticeable. According to absolute encoders position difference, there is a regulator tendency to cut down or eliminate skew. Simultaneously, with action of skew regulator, the effect of load sharing controller is active.

In the second section, the drive operates at constant speed. During the operation, trolley that moves between the fixed and free leg, is active. The efficiency of the algorithm can be seen from several aspects:

- skew during the acceleration is rapidly eliminated, regardless of the variable load as function of trolley position and load of conveyor;
- load sharing controller provides equal load distribution with respect to adjusted proportional gain and limiters value.

In the third section, during crane deceleration similar statements are valid. It is evident that before final crane stopping, an adjustment between legs occurs.

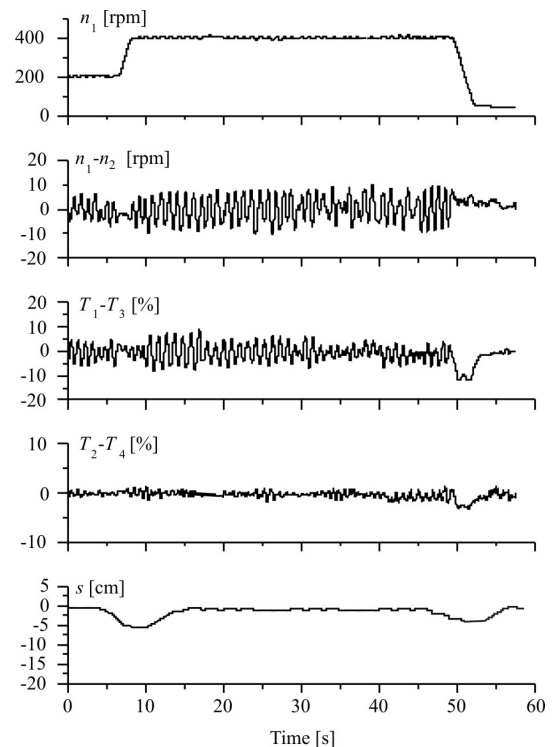

Fig. 14. *Behavior of gantry drives with skew controller during accelerate - steady state - decelerate period*

3 CONCLUSION

Presented results show how the delicate problems of controlled multimotor drives, which call into question the stability of the whole system and its work in general, can be overcome in a simple and inexpensive way. A wide span gantry crane served as an example of the considered problems of load sharing and skew elimination.

The following conclusion may be drawn from this study.

Applying modern converters and the appropriate algorithm realized in the PLC, a reliable solution for load sharing is shown. The solution is applicable in speed sensorless drives where the information about the speed and load torque is estimated from frequency converters.

The skew problem is solved by software, and for hardware implementation only two encoders are needed. This configuration also enables a realization of an external disturbance compensator. The main task was to provide skew supervision and adjustment of controlled value on previously defined positions.

The above described algorithms can be applied for various multimotor drive configurations, for example drives on common DC bus. The core of the system is PLC that communicates with the frequency converters and other devices over Profibus protocol. Information interchange between PLC, frequency converters and encoders enables simple realization of suggested algorithms.

4 ACKNOWLEDGEMENT

This work is a result of the project TR-6142 financially supported by the Ministry of Science and Technological Development of

Serbia. Mechanical Industry of Niš (MIN), as participant, uses these results.

5 REFERENCES

- [1] Busschots, F., Belmans, R., Geysen, W. (1991) Application of field oriented control in crane drives, *Proc. IEEE-IAS, Annual Meeting*, Dearborn, Michigan, p. 347-353.
- [2] Backstrand, J.E. (1992) The application of adjustable frequency drives to electric overhead cranes, *Industry Applications Society Annual Meeting*, Conference Record of the 1992 IEEE, vol. 2, p. 1986-1991.
- [3] Paul, A.K., Banerjee, I., Snatra, B.K., Neogi, N. (2008) Application of AC motors and drives in Steel Industries, *Fifteenth National Power System Conference*, Bombay, p.159-163.
- [4] Slutej, A., Kolonic, F., Jakopovic, Z. (1999) The new crane motion control concept with integrated drive controller for engineered crane application, ISIE'99, *Proc. of the IEEE International Symposium*, vol. 3, p.1458-1461.
- [5] Jeftenić, B., Bebic, M., Jevtic, D. (2001) Load distribution for mechanically coupled drives, *XI International Symposium on Power Electronics*, Ee 2001, Novi Sad, p.197-200.
- [6] Rockwell Automation, *Load Sharing for the 1336 PLUS II AC Drive*, Publication number 1336E-WP001A-EN-P, 2000.
- [7] Jeftenić, B., Bebic, M., Statkic, S. (2006) Controlled multi-motor drives, *International Symposium on Power Electronics, Electrical Drives, Automation and Motion*, SPEEDAM, Taormina, p. 1392-1398.