**OPTIMISED CALIBRATION PROCEDURE FOR BIOANALYTICAL
DETERMINATION OF ORGANOPHOSPHATE PESTICIDES IN APPLE
JUICES BY IMMOBILISED AChE**

Klavdija Mežnar, Boris Pihlar

*Faculty of Chemistry and Chemical Technology, University of Ljubljana, Aškerčeva 5,
SI-1000 Ljubljana, Slovenia*

Lea Pogačnik

*Biotechnical Faculty, Department of Food Science and Technology, University of Ljubljana,
Jamnikarjeva 101, SI-1000 Ljubljana, Slovenia*

Mladen Franko*

*Nova Gorica Polytechnic, School of Environmental Sciences, P.O.Box 301,
SI-5001 Nova Gorica, Slovenia*

Received 02-03-2003

Abstract

The bioanalytical method, based on flow injection analysis (FIA), was optimised for detection of organophosphate pesticides in apple juices. The matrix effects (pH value of the sample and presence of alkaline and alkaline earth metal ions) were studied. The activity of acetylcholinesterase (AChE), immobilised on controlled porosity glass, was found to be strongly dependent on the pH value of the mobile phase, which also influences the enzyme inhibition. The optimal pH value was found to be at 7.4. The presence of 0.1 M alkaline and alkaline earth metal ions decreased the enzyme activity for about 20%. In addition, a notable effect on the process of enzyme inhibition by pesticide paraoxon, which was chosen as a model organophosphate pesticide, was observed already when the concentrations of investigated ions were between 0.001 M and 0.01 M. For calibration purposes the standard solutions of paraoxon therefore need to be prepared with the addition of metal ions in concentrations corresponding to those present in investigated apple juice and the pH value of apple juice adjusted to 7.4 by the addition of Tris buffer.

Introduction

Significant progress in the development of bioanalytical methods for determination of biological and organic analytes was observed recently. The application of these methods leads to high biochemical specificity and selectivity. A suitable transducer (potentiometric, amperometric, conductometric, piezoelectric or optical) transforms the bioanalytical signal into the electric signal, which is specifically related to the concentration of selected analyte. When the bioanalytical part of the sensor is coupled to a sensitive transducer, very high sensitivity of the method can be achieved.

Spectrophotometers and fluorimeters are the most frequently used optical transducers. Spectrophotometric detection methods require analytical substrates that react with biochemically active substances (e.g. enzymes, immunological antibodies, cells or organisms) and yield coloured products either directly or after subsequent derivatisation. Fluorimetry offers higher sensitivity, but requires substrates yielding fluorescent products, or derivatisation with adequate chromophores. Recently, thermal lens spectrometry (TLS) has been demonstrated as a promising detection method for biosensors. TLS enables measurement of very low absorbances (10^{-7} AU), which leads to higher sensitivity, lower LOD, and shorter time of analysis.¹⁻⁴

Much progress has been lately made in the area of bioanalytical methods for determination of pesticides, particularly organophosphate and carbamate pesticides. These compounds are powerful inhibitors of cholinesterases (ChE), and can form stable complexes with cholinesterases, and prevent the enzyme function by phosphorylation. Several cholinesterase inhibition methods have been suggested for the determination of these toxic substances.¹⁻¹³ Most of them are based on detection of enzyme activity before and after application of the pesticide.

The matrix effect of fruit juices and tap water on the ChE inhibition has already been studied and is discussed elsewhere.¹ The calibration curves obtained with the pesticide dissolved in these two media differ from the calibration curves for paraoxon prepared in buffer solution, which was not adequately explained yet. Additionally, the influence of heavy metals (Zn^{2+} , Cu^{2+} , Pb^{2+} , Fe^{3+} , Sn^{2+} , Hg^{2+} , As^{3+} , As^{5+} , Co^{2+} , Cd^{2+} , Ni^{2+} and Mn^{2+}) on the enzyme activity has also been previously studied.¹³⁻¹⁷ It was shown that the effect is correlated to the size and the charge of the investigated metal rather than to its concentration. On the other hand, the research on influence of alkaline and alkaline earth metals on enzyme activity has not yet been performed. These metals represent a high proportion of apple juice matrix, which can influence the inhibition curves for determination of organophosphate and carbamate pesticides.

Therefore, the main objective of this work was to study the reason for mismatching of calibration curves for paraoxon, as a representative of organophosphate pesticides, dissolved in buffer solution and in apple juice and to prepare a more reliable optimized calibration curve, which would therefore enable accurate detection of organophosphate or carbamate pesticides in real samples of apple juices.

Experimental

Reagents

Acetylcholinesterase (AChE) (EC 3.1.1.7, type III, 950 U mg^{-1} , from electric eel), acetylthiocholine iodide (ATChI), 5,5'-dithiobis(2-nitrobenzoic acid) (DTNB) and controlled porosity glass (CPG 240, 80-120 mesh, mean diameter 22.6 nm) were obtained from Sigma Chemical. Tris (hydroxymethyl)-aminomethane (TRIS) was from Riedel-de Haën. A 0.05 M Tris buffer (pH 7.4) was used as a carrier buffer in all experiments, except when alkaline and alkaline earth metals were added. Aminoalkylating agent used for the enzyme immobilisation was prepared by dissolving 10 mL of 3-aminopropyltriethoxysilane (98% pure, from Sigma) in 90 mL distilled water. Cross-linking agent, glutaraldehyde (25% water solution from Merck) was prepared by dissolving 1 mL of 25% solution in Tris buffer (0.05 M, pH 7.4) to obtain 10 mL of the solution. A 250 ppb stock solution of diethyl p-nitrophenylphosphate (paraoxon) (90% pure, Aldrich) was prepared by dissolving the pesticide in Tris buffer (0.05 M, pH 7.4). A 36-38% solution of hydrochloric acid (J.T. Baker) was used to adjust the pH value of Tris buffer. Alkaline and alkaline earth salts: KCl (99% pure), CaCl₂ (anhydride) from J.T. Baker and NaCl (99.5% pure) from Carlo Erba and MgCl₂·6 H₂O (99% pure) from Sigma were used. A 1.0×10⁻¹ M stock solution of each metal was prepared in 0.05 M Tris buffer (pH 7.4).

MiliQ water was used throughout the experiments. All chemicals were of analytical-reagent grade.

Enzyme immobilisation

The enzyme immobilisation was carried out according to the procedure published elsewhere.⁵ The controlled-pore glass beads (CPG) with immobilised enzyme were stored at 4 °C in Tris buffer (pH 6.0). The immobilised enzyme was packed into polytetrafluoroethylene (PTFE) column (60×2.1 mm i.d.).

Instrumentation

The FIA manifold shown in Figure 1, consisted of a HPLC pump (Shimadzu LC-10Ai, Kyoto, Japan), two injection valves (Rheodyne) and UV-VIS Spectrophotometer (HP 8453 E diode array detector - DAD) equipped with a flow-through cell (Helma,

15 μL). The spectrophotometer was connected to a personal computer (PC) for data processing.

The carrier buffer (mobile phase) was pumped through the system at 0.5 mL/min. The substrate was injected via 20 μL injection loop through the first injection valve and the sample was injected through second injection valve (1.0 mL injection loop). The PTFE coil tubing (0.5 mm i.d.) was used to connect the set-up.

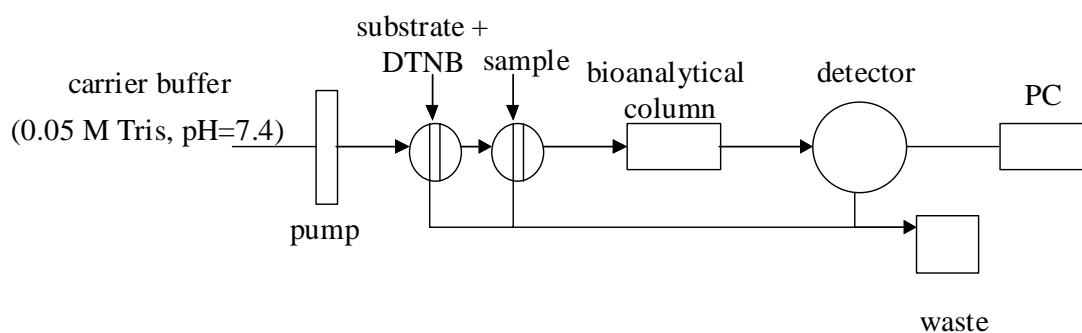

Figure 1. The FIA experimental set-up.

Principle of detection

The enzyme activity was assayed according to Ellman et al.¹⁸ and was based on two coupled reactions, yielding the yellow product 5-thio-2-nitrobenzoate (TNB^{2-}), which was detected with spectrophotometer at 410 nm.

The stock solution (250 ppb) of pesticide paraoxon was used throughout the experiments to prepare the inhibition curves for the method. The inhibition of the enzyme was measured by following steps:

1. measurement of the absorbance corresponding to the initial enzyme activity in the bioanalytical column (a_0) by at least three consecutive injections of the substrate
2. injection of a sample containing the pesticide
3. measurement of the absorbance corresponding to final enzyme activity (a_F) by injection of the substrate and calculation of remaining relative enzyme activity (A) according to the formula:

$$A = \frac{a_0}{a_F}$$

Results and discussion

Influence of pH

Initially, the previously developed bioanalytical method,¹⁻⁴ based on FIA and immobilised acetylcholinesterase (AChE) was tested for detection of standard solutions of paraoxon, which was selected as a model pesticide for this work. All solutions were prepared in Tris buffer. The bioanalytical column was packed with the sufficient amount of immobilised AChE, which yielded signals equal to (1 ± 0.1) AU for the initial enzyme activities. The concentration of the substrate acetylthiocholine iodide (ASChI) and the chromophore DTNB used for each assay of the enzyme activity was determined experimentally and was kept high enough to enable maximum response of the enzyme ($C_{ASChI} = 4.3$ mM, $C_{DTNB} = 0.25$ mM). The pH value of the Tris buffer solution, which was used as a mobile phase was 7.4. This represents the compromise between the optimum pH for enzymatic hydrolysis of the substrate (pH 8-9) and the pH where the substrate is still stable. Additionally, in Tris buffer the inhibition of AChE caused by a pesticide is the highest at pH 7.4, as previously shown for the case of paraoxon.^{1-4,13} Under such conditions the inhibitions between zero and 60%, determined after consecutive injections of the samples (1 mL), which contained the same concentration of paraoxon (250 ppb) in Tris buffer (pH 7.4), correlated linearly to the cumulative concentration of paraoxon (sum of concentrations in all consecutively injected samples) as shown on Figure 2.

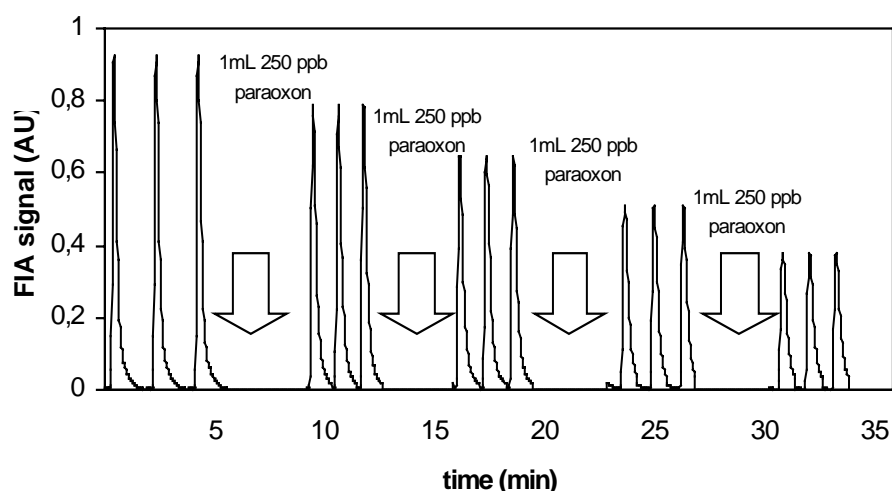

Figure 2. The decrease of FIA signals due to consecutive injections of buffer samples, containing 250 ppb paraoxon.

It was previously shown¹ that the inhibition of the immobilised AChE with pesticide dissolved in Tris buffer is considerably higher compared to the inhibition with the same concentration of pesticide dissolved in apple juice (pH 3.2). To circumvent this problem the pH of apple juice was adjusted to 7.4 with addition of Tris buffer. Despite the adjustment of the pH, the resulting calibration curve does not match the inhibition curve for pesticide prepared in buffer solution (Figure 3). The resulting inhibition curve is steeper than the one prepared for the buffer samples. This means higher inhibitions of the enzyme, when pesticide is dissolved in apple juice with pH adjusted to 7.4, compared to the inhibition caused by the same concentration of the pesticide dissolved in buffer solution. It is thus obvious that there are other substances present in the apple juice, which have significant effect on the enzyme activity and its inhibition. The possible influences were studied further as described below.

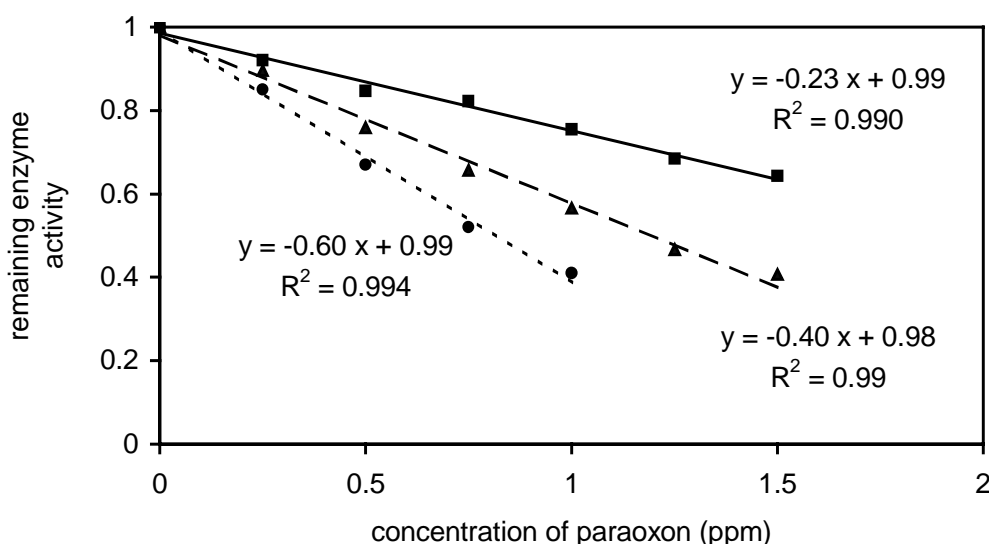

Figure 3. Calibration curves for detection of paraoxon dissolved in Tris buffer (dashed line), in apple juice with pH 3.2 (solid line) and in apple juice with pH adjusted to 7.4 (dotted line).

Influence of alkaline and alkaline earth metals on the enzyme activity

To determine the influence of alkaline and alkaline earth metals on enzyme activity the experiments with Tris buffer, containing different concentrations of metal ions (Mg^{2+} , Ca^{2+} , K^+ , Na^+) were preformed. It was observed that the enzyme activity was not

affected by the presence of metal ions in mobile phase at concentrations lower than 0.1 M, as illustrated by the effects of various concentrations (10^{-5} M to 10^{-1} M) of magnesium ions in Tris buffer on Figure 4. Two assays of the enzyme activities were performed for each concentration of magnesium ions. The first assay was performed three minutes after the replacement of the mobile phase (left column), and the second one after 13 minutes (right column).

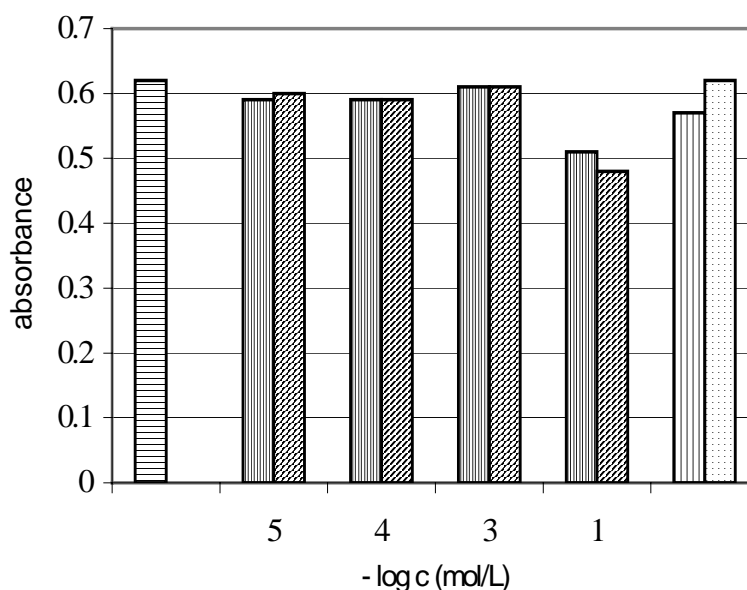

Figure 4. The influence of different concentrations of magnesium ions on the enzyme activity, expressed as the FIA signal following the injection of the substrate. The first column and the last two columns correspond to the enzyme activity in Tris buffer without addition of Mg^{2+} .

The responses were related to the signals, obtained in the pure buffer solution (first column). From these data the relative enzyme activities were calculated (Table 1) according to the formula:

$$a_r = \frac{a_x}{a_{\text{Tris}}} \quad \text{where,}$$

a_r is relative enzyme activity

a_x is FIA signal in the mobile phase containing different alkaline or alkaline earth ions in various concentrations

a_{Tris} is FIA signal in pure Tris buffer

Table 1. The relative enzyme activities in pure Tris buffer and in Tris buffer containing different alkaline and alkaline earth metal ions in various concentrations. The measurements were performed 3 minutes and 13 minutes after application of new mobile phase.

c _x (mol/L)	alkaline and alkaline earth metal ions							
	Ca ²⁺		Mg ²⁺		Na ⁺		K ⁺	
	3 min	13 min	3 min	13 min	3 min	13 min	3 min	13 min
TRIS	100 ± 2	–	100 ± 3	–	100 ± 4	102 ± 4	100 ± 3	–
10 ⁻⁵	102 ± 2	102 ± 2	95 ± 3	97 ± 3	102 ± 5	107 ± 5	100 ± 3	102 ± 5
10 ⁻⁴	102 ± 2	100 ± 2	95 ± 3	95 ± 3	105 ± 5	105 ± 5	102 ± 2	102 ± 2
10 ⁻³	105 ± 2	105 ± 2	98 ± 3	98 ± 3	102 ± 3	102 ± 5	102 ± 3	102 ± 5
10 ⁻¹	83 ± 2	81 ± 2	82 ± 1	79 ± 3	82 ± 4	81 ± 4	82 ± 2	81 ± 4
TRIS	–	104 ± 2	92 ± 7	100 ± 3	–	107 ± 5	–	98 ± 3

The significant decrease in the enzyme activity was observed only when the concentration of any of the tested metal ions was elevated to 0.1 M. At these concentrations of metal ions the enzyme activities were lowered by 20%. To study the reversibility of the process the mobile phase with metal ions was at the end of the experiment flushed out and replaced again with pure Tris buffer as mobile phase. In all cases this resulted in the enzyme activity (right-most two columns in Figure 4 and last row in Table 1), which was not significantly different from the enzyme activity determined at the beginning of the experiment in pure buffer solution. Once the metal ions are removed from the mobile phase the enzyme completely regains its initial activity.

Influence of alkaline and alkaline earth metals on the enzyme inhibition by paraoxon

To determine the influence of different alkaline and alkaline earth metal ions on the process of enzyme inhibition the experiments were performed with paraoxon dissolved in Tris buffer, containing metal ions in various concentrations (1.5 × 10⁻³ M Ca²⁺, 2.0 × 10⁻³ M Mg²⁺, 1.0 × 10⁻³ M Na⁺, 3.0 × 10⁻² M K⁺). Notable effects of metal ions on the inhibition of AChE by pesticide paraoxon were observed already at metal ion concentrations between 0.001 M and 0.01 M. In all cases the slopes of the inhibition curves are higher when metal ions were added to the paraoxon solutions compared to the inhibition curves obtained with pesticide dissolved in pure Tris buffer. Figure 5 shows the influence of different alkaline and alkaline earth ions, in concentrations corresponding to expected concentration ranges in apple juices (reference numbers of

fruit juices and nectars - RSK values,¹⁹ on inhibition of the enzyme. It can be observed that the inhibitions of the enzyme caused by paraoxon, dissolved in Tris buffer, containing different metal ions are higher compared to the inhibitions obtained after injection of the same concentration of paraoxon dissolved in pure Tris buffer. The inhibitions obtained in the presence of different metal ions differ considerably, being the highest in the case of Na^+ ions ($c = 1.0 \times 10^{-3}$ M) and the lowest in the case of K^+ ions ($c = 3.0 \times 10^{-2}$ M). The results show the differences between different metal ions and their influence on the enzyme inhibition. The differences in the observed effects are much more related to the ion itself than to its concentration.

The described observations indicate that alkaline and alkaline earth ions, which are present in apple juice, have significant effect on the bioanalytical determination of the pesticides present in the samples.

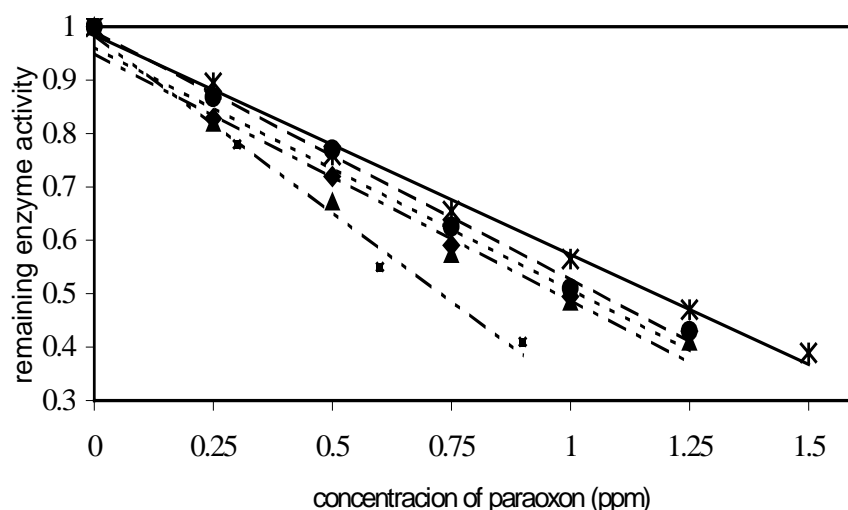

Figure 5. The influence of alkaline and alkaline earth metals on the inhibition of the enzyme. Solid line – pure Tris buffer, dashed line – Tris buffer containing 1.5×10^{-3} M Ca^{2+} , dotted line – Tris buffer containing 3.0×10^{-2} M K^+ , dash-dotted line – Tris buffer containing 2.0×10^{-3} M Mg^{2+} , dash-dot-dotted line – Tris buffer containing 1.0×10^{-3} M Na^+ .

The joint effect of selected alkaline and alkaline earth metals on the sensitivity of described bioanalytical method was evaluated and confirmed by further experiments. The inhibition curve for paraoxon was prepared, using pure Tris buffer (pH 7.4) as a mobile phase, whereas the paraoxon was dissolved in Tris buffer (pH 7.4) containing

alkaline and alkaline earth metal ions in concentrations equal to those expected in apple juices available on the market (RSK values). The calibration curve for paraoxon prepared in mobile phase with addition of metal ions corresponds well to the calibration curve for paraoxon prepared in apple juice with addition of Tris buffer (pH 7.4). It can be observed from Figure 6 that the slopes for the two mentioned calibration curves are identical, whereas the calibration curve for paraoxon, prepared in pure Tris buffer is significantly less steep. It is thus obvious that it is necessary to add the suitable chemicals to the standard pesticide solution to simulate the real samples prior to preparation of calibration curve or to prepare calibration standards in non-contaminated juice sample. With a similar approach the problems occurring during analysis due to matrix effects can be avoided in other samples (other fruit or vegetable juices, vegetable samples) as well.

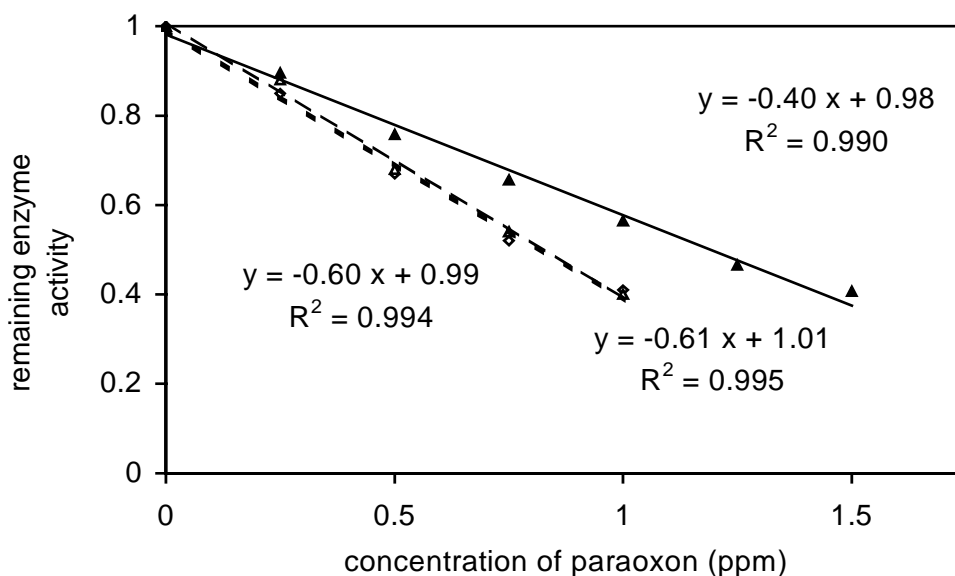

Figure 6. Calibration curves for paraoxon prepared in Tris buffer (pH 7.4) with addition of metal ions (dashed line), for paraoxon prepared in apple juice with pH adjusted to 7.4 (dotted line) and for paraoxon prepared in pure Tris buffer (solid line).

Conclusions

It was shown in this work that alkaline and alkaline earth metal ions in concentrations below 0.1 M have little effect on AChE activity, when the enzyme is incorporated in a FIA system for bioanalytical determination of organophosphate and

carbamate pesticides. On the contrary, the inhibition of the enzyme by paraoxon is already increased by the presence of metal ions in concentrations of 0.001 M. For this reason, standard solutions used for calibration purposes when determining organophosphates in apple juices were prepared using paraoxon as model pesticide in Tris buffer (pH 7.4) with added alkaline and alkaline earth metals (Mg^{2+} , Ca^{2+} , K^+ , Na^+) in concentrations equal to those expected in apple juices available on the market (RSK values). It was found to be important to adjust the pH value of the sample (apple juice) with addition of Tris buffer instead of using strong inorganic bases (e.g. NaOH). The proper adjustment of the pH and addition of alkaline and alkaline earth-metals has resulted in calibration curve that exactly matched the calibration curve for paraoxon dissolved in apple juice. It is important to prepare matrix matched standards in order to obtain reliable inhibition curves, which serve as reference when the analysis of real sample is performed. Similar situation is expected also with other samples, where organophosphate or carbamate pesticides can be expected (e.g. other fruit juices, fruit or vegetable extracts).

Acknowledgements

This work was supported by the Slovenian Ministry of Education, Science and Sport.

References

1. L. Pogačnik, M. Franko, *Biosens. Bioelectr.* **1999**, 14, 569–578.
2. L. Pogačnik, M. Franko, *Talanta* **2001**, 54, 631–641.
3. L. Pogačnik, M. Franko, *Ann. di Chim.* **2002**, 92, 93–101.
4. L. Pogačnik, M. Franko, *Biosens. Bioelectr.* **2003**, 18, 1–9.
5. M. E. Leon-Gonzalez, A. Townshend, *Anal. Chim. Acta* **1990**, 236, 267–272.
6. T. Krawczynski vel Krawczyk, *Chem. Anal. (Warsaw)* **1998**, 43, 135–158.
7. A. N. Ivanov, G. A. Evtugyn, R. E. Gyurcsanyi, K. Toth, H. C. Budnikov, *Anal. Chim. Acta* **2000**, 404, 55–65.
8. G. S. Nunes, D. Barcelo, B. S. Grabaric, J. M. Diaz-Cruz, M. L. Ribeiro, *Anal. Chim. Acta* **1999**, 399, 37–49.
9. D. Martorell, F. Cespedes, E. Martinez-Fabregas, S. Alegret, *Anal. Chim. Acta* **1997**, 337, 305–313.
10. M. Bernabei, C. Cremisini, M. Mascini, G. Palleschi, *Anal. Lett.* **1991**, 24, 1317–1331.
11. W. Russell, G. A. Rechnitz, *Anal. Lett.* **1999**, 32, 1–10.
12. J. M. Abad, F. Pariente, L. Hernandez, H. D. Abruna, E. Lorenzo, *Anal. Chem.* **1998**, 70, 2848–2855.
13. K. Stein, S. Scmechel, *J. Prakt. Chem.* **1996**, 338, 114–120.
14. M. R. Pavlič, S. Šoškić, M. Zorko, *Yugoslav. Physiol. Pharmacol. Acta* **1979**, 15, 71–85.
15. N. F. Starodub, N. I. Kanjuk, A. L. Kukla, Yu. M. Shirshov, *Anal. Chim. Acta* **1999**, 385, 461–466.
16. M. Stoytcheva, *Bull. Soc. Chim. Belg.* **1994**, 103, 147–149.

17. M. Stoytcheva, V. Sharkova, M. Panayotova, *Anal. Chim. Acta* **1998**, *364*, 195–201.
18. G. L. Ellman, K. D. Courtney, V. Andres, JR, R. M. Featherstone, *Biochem. Pharmacol.* **1961**, *7*, 88–95.
19. Code of Practice for Evaluation of Fruit and Vegetable Juice; AIJN (Association of the Industry of Juices and Nectars from Fruits and Vegetables of the European Union), **2002**.

Povzetek

Optimizirali smo metodo za detekcijo organofosfatnih pesticidov v jabolčnem soku. Študirali smo vpliv vrednosti pH in prisotnost alkalijskih in zemeljsko alkalijskih kovin v soku. Aktivnost encima acetilholinesteraze (AChE), imobiliziranega na CPG steklo, je močno odvisna od vrednosti pH nosilne raztopine in vzorca. Optimalna vrednost pH delovanja encima in njegove inhibicije je 7,4. Vpliv alkalijskih in zemeljsko alkalijskih kovin na aktivnost encima AChE je opazen šele tedaj, ko so koncentracije posameznih kovinskih ionov v nosilni raztopini 0,1 M. Prisotnost omenjenih kovin v vzorcih paraoksone ima vpliv na encimsko inhibicijo že v koncentracijskem območju med 0,001 M in 0,01 M. Zato smo pripravili standardne raztopine paraoksone v nosilni tekočini z dodatkom kovinskih ionov v koncentracijah, ki so značilne za jabolčni sok (RSK vrednosti), vrednost pH jabolčnega soka pa smo uravnali s 3,2 na 7,4 z dodatkom Tris pufra. S tem smo dosegli optimalno delovanje bioanalitske kolone, ki vsebuje imobiliziran encim AChE.