

INFLUENCE OF THE HIP PROCESS ON THE PROPERTIES OF AS-CAST Ni-BASED ALLOYS

VPLIV VROČEGA IZOSTATSKEGA STISKANJA NA LASTNOSTI Ni-ZLITIN Z LITO STRUKTURO

**Jitka Malcharcziková¹, Martin Pohludka¹, Vít Michenka², Tomáš Čegan¹,
Jan Juřica¹, Miroslav Kursa¹**

¹VŠB-Technical University of Ostrava, Faculty of Metallurgy and Materials Engineering, Department of Non-Ferrous Metals, Refining Processes and Materials Recycling, Regional Materials Science and Technology Centre, 17. listopadu 15/2172, 708 33 Ostrava - Poruba, Czech Republic

²VÚHŽ a.s., Dobrá 240, 739 51 Dobrá, Czech Republic
jitka.malcharczikova@vsb.cz

Prejem rokopisa – received: 2013-09-30; sprejem za objavo – accepted for publication: 2014-01-30

The main goal of this work was to evaluate the application of the samples prepared by centrifugal casting as the test samples for a tensile test. Selected types of modified superalloys were prepared as experimental samples. The samples were molten by vacuum-induction melting and then cast centrifugally into a shaped graphite mould. The final castings had the shape corresponding approximately to the test specimens. Some of the samples were subjected to hot isostatic pressing (HIP). After HIP the castings contained substantially fewer casting defects. Selected mechanical properties were compared for the samples in the as-cast state and after HIP. For the majority of the investigated alloys the HIP process led to an increase in the strength and ductility.

Keywords: Ni-based alloys, centrifugal casting, hot isostatic pressing, mechanical properties

Glavni cilj tega dela je bila ocena uporabnosti vzorcev za natezni preizkus, izdelanih s centrifugalnim litjem. Preizkusni vzorci so bili izdelani iz izbrane vrste modificiranih superzlitin. Vzorci so bili staljeni v vakuumski indukcijski peči in centrifugalno uliti v izoblikovane grafitne forme. Ulitki so imeli obliko, ki ustreza vzorcem za natezne preizkuse. Del vzorcev je bil vroče izostatsko stisnjen (HIP). Ulitki so imeli po obdelavi HIP občutno manj livarskih napak. Izbrane mehanske lastnosti so bile primerjane pri vzorcih v litem stanju in po obdelavi HIP. Pri večini preiskovanih zlitin je obdelava HIP povzročila povečanje trdnosti in duktilnosti.

Ključne besede: Ni-zlitine, centrifugalno litje, vroče izostatsko stiskanje, mehanske lastnosti

1 INTRODUCTION

Ni-based alloys, including the alloys based on inter-metallic compounds (IMC) and superalloys are still in the forefront of interest. These alloys that can be used even at high temperatures are continuously investigated thanks to their excellent mechanical and corrosion properties^{1,2}. The technology of hot isostatic pressing (HIP) belongs, within the powder metallurgy, to the methods of hot sintering, during which the powder achieves the required properties as a result of the effect of predominantly physical processes. The HIP method is successfully used also for additional compacting of castings, ensuring a homogenisation of the structure and a reduction of the pores and shrinkage cavities. This method is used also for the alloys based on nickel and Ni₃Al. Numerous data were published on sintering powder-pressed pieces made of the materials based on Ni³⁻⁶. Kim⁷ describes a procedure for additional compacting of the castings made of alloys IC396. Many problems occur when processing the samples with the usual production methods. The methodology for processing to the specified dimensions is highly demanding and expensive. A large amount of experimental material is

damaged⁸ and the testing of the mechanical properties of this type of material is, therefore, very difficult.

The most frequent use of hot isostatic pressing is a compaction of powder materials^{4,9-12}. There are several papers dealing with the compaction of nickel-alloy castings with the HIP method¹³⁻¹⁵. Nickel-alloy castings consist of large and irregular grains of the γ' phase. This phase continues to coarse during the HIP process at a high temperature and pressure^{4,9,12,15}. In some cases, carbides and the δ phase precipitate at the grain boundaries after a HIP process¹¹. All of the above has a negative influence on the mechanical properties of nickel alloys. Therefore, after a HIP process, nickel alloys should be heat treated by solution annealing and aging^{11,12}.

2 EXPERIMENT

Selected types of modified superalloys IC50, IC396, IC221M and IC438 were prepared as the experimental samples. They were molten by vacuum-induction melting and then cast centrifugally into a shaped graphite mould (**Figure 1**). The final castings had the shape corresponding approximately to the test specimens

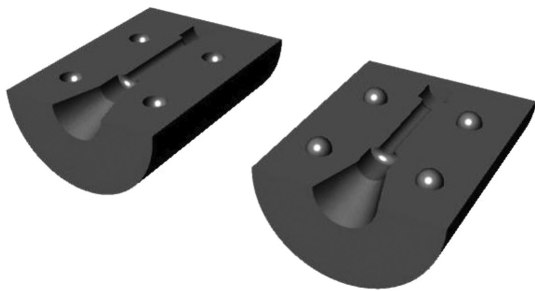

Figure 1: Graphite-mould drawing
Slika 1: Risba grafitne forme

(Figure 2). The compositions of the alloys were derived from the already verified and industrially used types of alloys for the given applications, and their compositions are presented in Table 1 (A: the state after HIP, B: the as-cast state).

Table 1: Chemical composition of the used samples in mass fractions, w/%

Tabela 1: Kemijska sestava uporabljenih vzorcev v masnih deležih, w/%

Alloy	Sample	Amounts of elements					
		Al	Cr	Mo	Zr	B	Ni
IC50	3A, 3B	11.30	-	-	0.60	0.01	88.08
IC396	4A, 4B	7.98	7.72	3.02	0.85	0.01	80.42
IC221M	5A, 5B	8.00	7.70	1.43	1.70	0.01	81.10
IC438	6A, 6B	8.10	5.23	7.02	0.13	0.01	79.52

A flaw-detection method with X-ray radiation was used for determining the quality of the castings. The pattern of distribution and the type of casting defects were similar in all the centrifugally cast samples. Figure 3 schematically shows their location and size. Defects occurred on the tapered part of the test piece (the tensile bar body), or in the direction towards the head, on the part of the casting without a riser.

2.1 Hot isostatic pressing (HIP)

It was established after a flaw-detection analysis, that the castings contained numerous casting defects. That is why some of the samples were subjected to hot isostatic pressing (HIP). The conditions for HIP were derived from the literature sources³⁻⁷. Hot isostatic pressing was performed on a press of the EPSI company. In the first stage of the additional compacting we chose a pressure of 100 MPa, the time of 4 h and a temperature of 1100

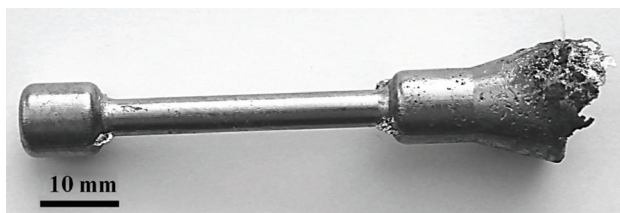

Figure 2: Sample after the casting
Slika 2: Vzorec po ulivanju

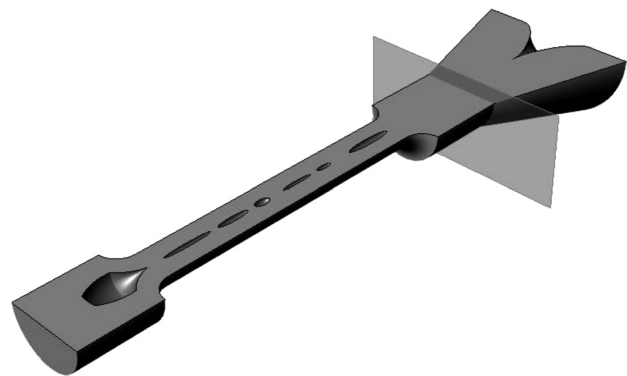

Figure 3: Scheme of casting defects
Slika 3: Shematski prikaz livarskih napak

°C. Using flaw detection, we established that the castings subjected to HIP under the pressure of 100 MPa still contained a considerable amount of casting defects. For this reason we increased the pressure to 150 MPa for the HIP process, while the time of 4 h and the temperature of 1100 °C remained unchanged. However, even after applying a higher pressure the castings still contained casting defects, but to a much smaller extent than in the state just after centrifugal casting.

Due to sufficient compaction, hot isostatic pressing can create a homogenous structure with a reduced number of pores and casting defects (shrinkage cavities and contractions) even in castings. This was confirmed in our case as well. After HIP, the castings contained substantially fewer casting defects.

2.2 Testing of the mechanical properties

Some of the samples in the as-cast state and the samples after HIP were ground to precise dimensions of the test piece and the tensile testing was performed. Short tensile bars with a length of 55 mm and a diameter of the central part of the bar of 5 mm were prepared by lathe turning. The strain rate was approximately $9.1 \cdot 10^{-4} \text{ s}^{-1}$ for all the samples. Table 2 gives the measured values of the tensile stress at yield, the ultimate engineering stress and the proportional elongation after braking. The table also contains the average values of the porosity and micro-hardness.

Table 2: Obtained mechanical characteristics

Tabela 2: Dobljene mehanske lastnosti

Sample No.	$R_{p0.2}$ /MPa	R_m /MPa	A /%	Porosity %	HV 0.05
3A	239	949	32	0.0309	302
3B	313	824	19	0.0393	249
4A	539	668	6	0.0123	353
4B	720	754	6	0.0743	336
5A	550	995	28	0.0486	354
5B	653	776	7	0.0496	324
6A	463	807	10	0.0589	359
6B	771	817	5	0.0614	351

3 DISCUSSION

We performed a comparison of the selected mechanical properties in the as-cast state and after HIP. In the majority of the investigated alloys the HIP process led to an increase in the determined strength and elongation. It is evident from the comparison of the values in **Table 2** that a significant enhancement of the mechanical properties after the HIP process occurred in samples 3 and 5, while no significant improvement of these values took place in samples 4 and 6. The R_m value of sample 4 does not correspond to the expected values. The casting probably contained a larger volume of casting defects before the HIP process. **Figure 4** shows the stress-strain curves for samples 3 and 5 in the as-cast state and after HIP. It may be concluded from the results that the process of additional compaction of the castings with the HIP method under the given conditions has a positive influence.

Figures 5 to 8 show the structures of samples 3 and 5 in the as-cast state and after HIP. The HIP process caused a coarsening of the grains as observed on **Figures 5 and 7**. This change in the structure was reflected by the

changes in the yield strength. The value of the yield strength dropped for all the types of alloys (**Table 2, Figure 4**). The gained results were already confirmed in the conclusions of the papers of other authors⁴⁻¹⁵. According to these results every nickel alloy reacts differently to the HIP process. To avoid a decrease in the mechanical properties of the castings, their grains should be as small as possible and the microstructural changes

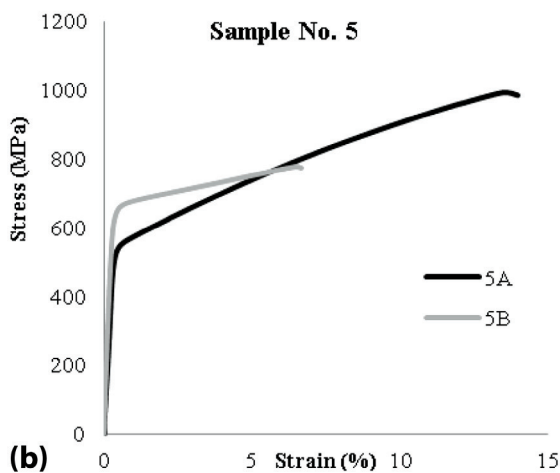
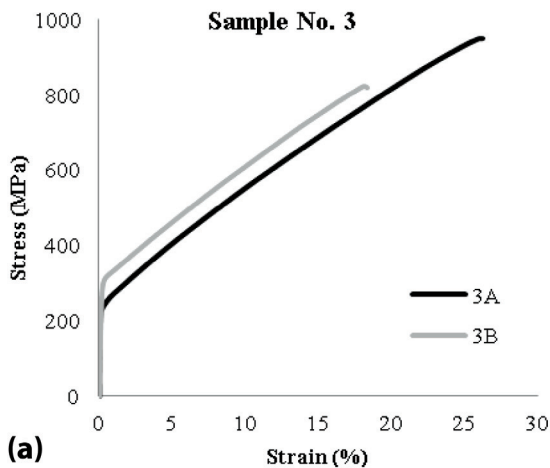

Figure 4: Stress-strain curves for: a) samples No. 3 and b) samples No. 5

Slika 4: Krivulje napetost – raztezek za: a) vzorca št. 3 in b) vzorca št. 5

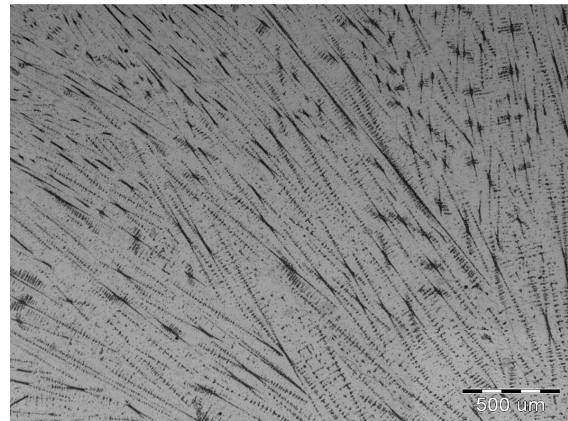

Figure 5: Microstructure of sample 3A

Slika 5: Mikrostruktura vzorca 3A

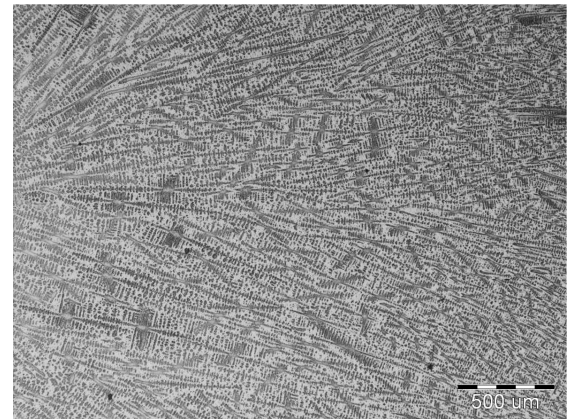

Figure 6: Microstructure of sample 3B

Slika 6: Mikrostruktura vzorca 3B

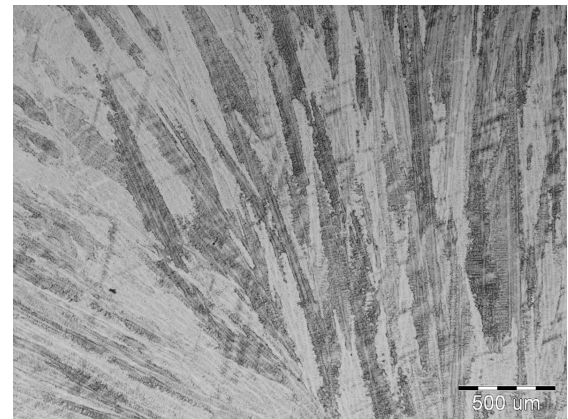

Figure 7: Microstructure of sample 5A

Slika 7: Mikrostruktura vzorca 5A

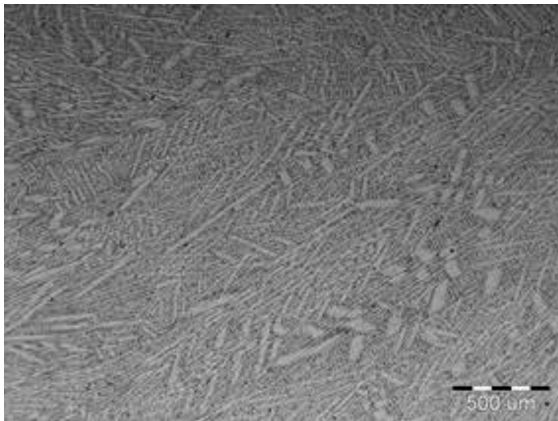

Figure 8: Microstructure of sample 5B
Slika 8: Mikrostruktura vzorca 5B

of these alloys should be studied during the HIP process. The porosity and micro-hardness are approximately the same for both the as-cast state and the HIP state. However, for all the experimental alloys the value of porosity decreased after the HIP process.

In practise it is possible to prepare the samples for evaluating the selected mechanical properties using the method of centrifugal casting of precision castings. The use of precision castings as the test specimens brings considerable savings of the materials and machining costs. The alloys of this type are used for high-temperature applications and a modification of the alloy composition is still performed¹⁶.

4 CONCLUSIONS

Modified Ni superalloys were prepared as the experimental samples. The samples were molten by vacuum-induction melting and then cast centrifugally into a shaped graphite mould. The final castings had the shape corresponding to the test specimens. After a flaw-detection analysis, it was established that the castings contained numerous casting defects. As a result, some of the samples were subjected to hot isostatic pressing (HIP). Hot isostatic pressing reduced the number of the pores and casting defects in the castings. We performed a comparison of selected mechanical properties in the as-cast state and after HIP. For the majority of the investigated alloys, the HIP process led to an increase in the strength and ductility.

Acknowledgement

The presented results were obtained within research project TA 01011128 "Research and development of centrifugal casting technology of the Ni-based inter-metallic compounds" and project CZ.1.05/2.1.00/01.0040 "Regional materials science and technology centre".

5 REFERENCES

- ¹ A. Milosavljevic et al., The influence of the heat-treatment regime on a fracture surface of nickel-based superalloys, *Mater. Tehnol.*, 46 (2012) 4, 411–417
- ² M. Oruč et al., Alloys with modified characteristics, *Mater. Tehnol.*, 45 (2011) 5, 483–487
- ³ C. García et al., Improvement of the ductility of a bimodal microstructured PM Ni₃Al by thermal treatment, *Materials Science and Engineering A*, 303 (2001), 11–18
- ⁴ J. G. Berriocanal et al., Microstructure and mechanical properties of Ni₃Al base alloy reinforced with Cr particles produced by powder metallurgy, *Intermetallics*, 14 (2006), 456–463
- ⁵ V. A. C. Haanappel et al., The cyclic oxidation behavior of PM Ni₃Al in air at elevated temperatures: the effect of Cr- and Y-implantation, *Intermetallics*, 6 (1998), 347–356
- ⁶ P. Pérez et al., Influence of the powder particle size on tensile properties of Ni₃Al processed by rapid solidification and hot isostatic pressing, *Materials Science and Engineering A*, 199 (1995), 211–218
- ⁷ H. K. Kim et al., High temperature deformation and fracture mechanism in a dendritic Ni₃Al alloy, *Acta Metallurgica et Materialia*, 42 (1994), 679–687
- ⁸ J. Malcharcziková et al., Non-alloyed Ni₃Al based alloys – preparation and evaluation of mechanical properties, *Metalurgija*, 52 (2013), 309–312
- ⁹ C. L. Qui et al., Influence of hot isostatic pressing temperature on microstructure and tensile properties of a nickel-based superalloy powder, *Materials Science and Engineering A*, 564 (2013), 176–185
- ¹⁰ L. S. Ng et al., Cold-hot isostatic pressing of Mar M200 superalloy powder, *Journal of Materials Processing Technology*, 67 (1997), 143–149
- ¹¹ L. Chang et al., Effect of heat treatment on microstructure and mechanical properties of the hot-isostatic-pressed Inconel 718 powder compact, *Journal of Alloys and Compounds*, 590 (2014), 227–232
- ¹² C. Qiu et al., Influence of heat treatment on microstructure and tensile behaviour of a hot isostatically pressed nickel-based superalloy, *Journal of Alloys and Compounds*, 578 (2013), 454–464
- ¹³ M. T. Kim et al., Effect of high pressure on the solid-liquid phase change of a nickel base superalloy during hot isostatic pressing, *Journal of Alloys and Compounds*, 477 (2009), 224–232
- ¹⁴ M. T. Kim et al., Effect of γ' precipitation during hot isostatic pressing on the mechanical property of a nickel-based superalloy, *Materials Science and Engineering A*, 480 (2008), 218–225
- ¹⁵ H. Y. Bor et al., Influence of isostatic pressing on the fracture transitions in the fine grain MAR-M247 superalloys, *Materials Chemistry and Physics*, 84 (2004), 284–290
- ¹⁶ J. Malcharcziková et al., Evaluation of structure characteristics of centrifugally cast alloy based on Ni₃Al, 21st International Conference on Metallurgy and Materials, Metal 2012, Brno, 2012, 1280–1287