

GRAPHITE-FLAKE CARBON-BLACK-REINFORCED POLYSTYRENE-MATRIX COMPOSITE FILMS DEPOSITED ON GLASS-FIBER WOVEN FABRICS AS PLANE HEATERS

KOMPOZIT POLISTIRENA, OJAČAN Z GRAFITNIMI LUSKAMI IN SAJAMI, NANESEN NA TKANINO IZ STEKLENIH VLAKEN ZA PLOŠČATE GRELNIKE

Mustafa Erol^{1,2,3}, Erdal Çelik^{1,2}

¹Dokuz Eylül University, Department of Metallurgical and Materials Engineering, Buca, 35160 Izmir, Turkey

²Dokuz Eylül University, Center for Production and Applications of Electronic Materials (EMUM), Buca, 35160 Izmir, Turkey

³Dokuz Eylül University, Graduate School of Natural and Applied Sciences, Buca, 35160 Izmir, Turkey
m.erol@deu.edu.tr

Prejem rokopisa – received: 2012-05-07; sprejem za objavo – accepted for publication: 2012-07-04

Graphite-flake carbon-black/polystyrene composite films as plane heaters are promising materials since they are smarter than the traditional heating elements. In the present study, we are concerned mainly with the production, characterization and industrial application of graphite-flake carbon-black-reinforced polystyrene-matrix composite films deposited on glass-fiber woven fabrics as plane heaters. Within this scope, graphite flakes and carbon-black powders were dispersed in polystyrene gel and deposited on glass-fiber woven fabrics with different weight ratios. Subsequently, the films were dried at 60 °C for 30 min in the air. Structural and surface properties of the produced films were characterized with XRD and SEM, respectively. Electrical and heating properties were determined with a hand-made experimental setup containing a multimeter and a thermocouple. It was found that uniform and partially ordered films depending on the weight ratio and percolation threshold were obtained as plane heaters. Planar heating of up to 60 °C was observed with a 24-V DC power supply.

Keywords: plane heater, composite, graphite flake, carbon black, conductive polymer

Kompozitne plasti polistirena z grafitnimi luskami – sajami so obetajoči materiali za ploščate grelnike, ker so „pametnejši“ od tradicionalnih grelnih elementov. V tej študiji obravnavamo proizvodnjo, karakterizacijo in industrijsko aplikacijo kompozitne tanke plasti polistirena, ojačanega z grafitnimi luskami – sajami, nanesenega na tkanino iz steklenih vlaken, za ploščate grelnike. S tem namenom so bile v tej študiji grafitne luske in saje razpršene v polistirenskem gelu, nanese v različnem masnem razmerju na tkanino iz steklenih vlaken. Nato so bile tanke plasti sušene pri 60 °C 30 min na zraku. Strukturne in površinske lastnosti nastalih tankih plasti so bile ocenjene z XRD in SEM. Električne in grelne lastnosti so bile določene z ročno izdelano sestavo, ki vsebuje multimeter in termoelement. Ugotovljeno je bilo, da je pri ploščatih grelnikih enakomerna in delno urejena plast odvisna od razmerja mas in deleža pronicanja. Pri uporabi enosmerne napetosti 24 V je bilo opaženo segrevanje ploščatih grelcev do 60 °C.

Ključne besede: ploščati grelnik, kompozit, grafitne luske, saje, prevoden polimer

1 INTRODUCTION

Polymers with their specific nature are known as good insulators for electronic applications. Developments of the polymers, together with the new researches, have focused on desired conductivities and a wide range of application for decades. The conductivity of polymers can be obtained in two ways: (a) by producing a polymer that is intrinsically conductive or can be made so by doping and (b) by loading an electrically insulating matrix with conductive fillers¹. The fillers, which involve conductivity, are generally based on metallic materials such as Ni, Cu, Ag, Al and Fe²⁻⁴ as well as carbon derivatives such as carbon black, carbon fiber, graphite and carbon nanotube⁵⁻⁸.

Natural graphite is mostly used in refractories, steel-making (as a heating element/electrode), expanded graphite, brake linings, foundry facings and lubricants. The heating property of graphite is a significant issue for electric-arc furnaces in the steel industry. As heating has

been an important process for humankind for ages, the above issue has also been present since the discovery of fire up until today's modern heating technologies. With respect to heating, fires, stoves, heat exchangers, air conditioners, furnaces, irons, floor heaters, etc. are the products that fulfill this requirement. These heating systems generally use fossil fuels (wood, petroleum, natural gas, etc), as well as solar energy and electricity. Due to the physical nature of heated air, it flows from bottom to top in a heated place. Taking this into account, efficient systems for heating, like floor heaters, can be selected. There are many detailed researches on floor heating in several reports⁹⁻¹². In addition, due to their conductive properties, graphite and carbon-black powders were incorporated into its structure to provide for the resistivity of the final composite structure. Nevertheless, to the best of our knowledge, no experimental work has been reported in the literature on the self-heating properties of polymer-graphite and carbon-black

composites and their application as plane heaters using composite films.

The fabrication of uniform graphite-flake carbon-black/polystyrene composite films is impossible by using conventional methods such as melting and heating because of several difficulties. To circumvent this problem, as explained in ref.¹, a similar gelation technology was employed to dissolve polystyrene pellets in a quickly evaporating solvent. Graphite-flake and carbon-black powders were dispersed in a polystyrene-chloroform gel matrix with different concentrations. The obtained gel containing these powders was deposited on glass-fiber woven fabrics to obtain the intended plane heaters. Then the structure, the surface morphology, as well as electrical and heating properties of the deposited composite films were investigated.

2 EXPERIMENTAL DETAILS

Graphite flakes (Tupras), carbon black (Selen Chemistry), polystyrene pellets (Tupras Petkim) and chloroform (Aldrich) were commercially provided to produce a new-generation heating element. Polystyrene pellets were dissolved in chloroform using an ultrasonic bath for 60 min and subsequently a viscous gel was obtained prior to depositing the composite films. Graphite-flake and carbon-black powders were basically added to obtain the gel as schematically illustrated in **Figure 1**. After these processes, graphite-flake carbon-black-reinforced polystyrene-matrix mixtures were prepared for the plane-heating composite element. The strategy for determining the composite samples was based on a composite including the total powder weight against the

polystyrene weight with a ratio of 0.6 that is referred to as X. Here the coefficient of X as 1, 2 and 4 means that the ratios are 0.6, 1.2 and 2.4, respectively. Beside this, the weight ratio of carbon black/graphite flake was determined as C/G = 0.62 for the composites including 1X, 2X and 4X. In order to determine individual effects of the powders on the properties, the composites containing just carbon black and just graphite were prepared as 1XC and 1XG, respectively. The details and definitions of the above mixture specifications were noted in **Table 1**.

Table 1: Mixture specifications and content data

Tabela 1: Pregled mešanic in podatki o vsebnosti

Precursor	4X*	2X*	1X*	1XG*	1XC*
Polystyrene (g)	1	1	1	1	1
Chloroform (ml)	8	8	8	8	8
Carbon black (g)	0.92	0.46	0.23	0.6	0
Graphite (g)	1.48	0.74	0.37	0	0.6

*X indicates a composite having the mass ratio C/G = 0.62

Coefficients of X indicate (C + G)/P

As the substrate choice is an important parameter for any film-deposition technique, glass-fiber, woven fabric substrates with a planar density of 100 g/m² were chosen because of their flexibility and high-temperature service abilities. The produced mixtures were spray painted on these substrates using an air-compressor-based mechanism. After that deposited films were dried to remove the solvent at 60 °C for 30 min on a hot plate for three times.

X-ray diffraction (XRD, Rigaku D/MAX-2200/PC) patterns of the coatings were determined to identify the phase structure using a diffractometer with CuK_α irradiation. The surface properties of the films were examined with the help of scanning electron microscopy (SEM, JEOL JSM 6060).

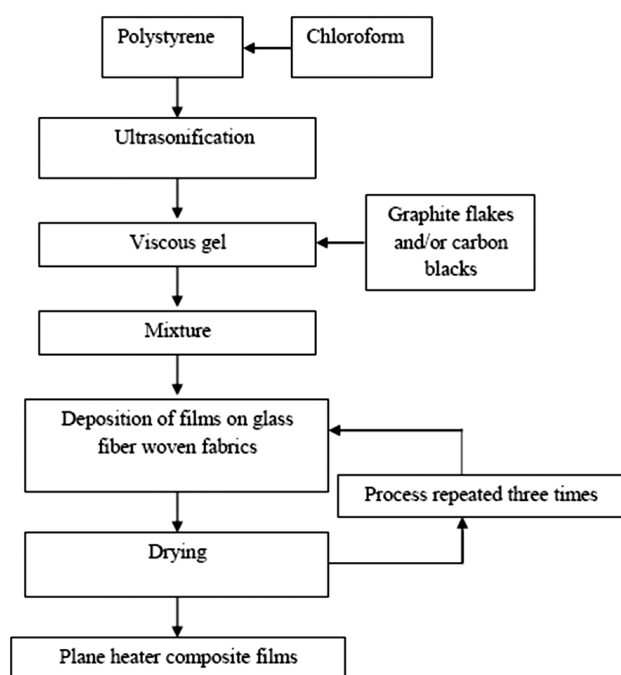

Figure 1: Schematic illustration of the process

Slika 1: Shematski prikaz procesa

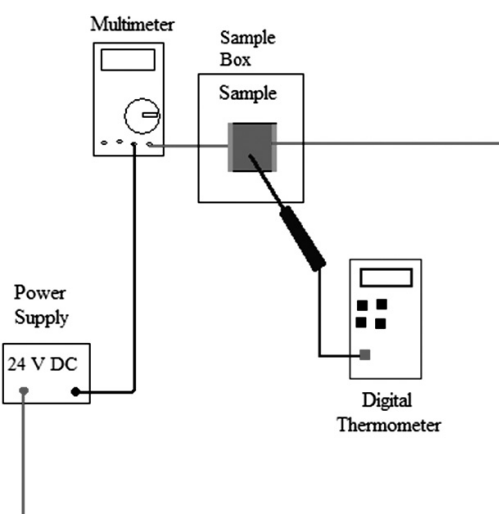

Figure 2: Experimental setup for determining electrical and heating properties of composite films

Slika 2: Eksperimentalni sestav za določanje električnih in grelnih lastnosti kompozitnih tankih plasti

Electrical and heating properties of the composite coatings were determined using the basic experimental setup as illustrated in **Figure 2**. This basic setup consisted of a digital thermometer, a 24-V direct-current (DC) power supply and a multimeter (used as an amperemeter in this circuit). Square specimens with the dimensions of 30 mm × 30 mm were cut and electrodes were painted on two edges with a silver paste as depicted with the orange color in **Figure 2**. The specimens were fixed to the circuit using copper jaws. The circuit current and the time versus the temperature data were noted from this set up. The resistances of the film were basically calculated using Ohm's law.

3 RESULTS AND DISCUSSION

The XRD patterns of the produced composite films on the glass-fiber woven fabrics are demonstrated in **Figure 3** in order to prove that their structure consists of both graphite flakes and carbon-black powder. As seen from the XRD patterns, the main peaks of graphite and carbon were determined at the diffraction angle of 26.6° . With respect to increasing the total powder amount, higher proportional-intensity data was recorded retaining the mixture contents listed in **Table 1**. In addition, crystalline-like polystyrene structure was clearly found

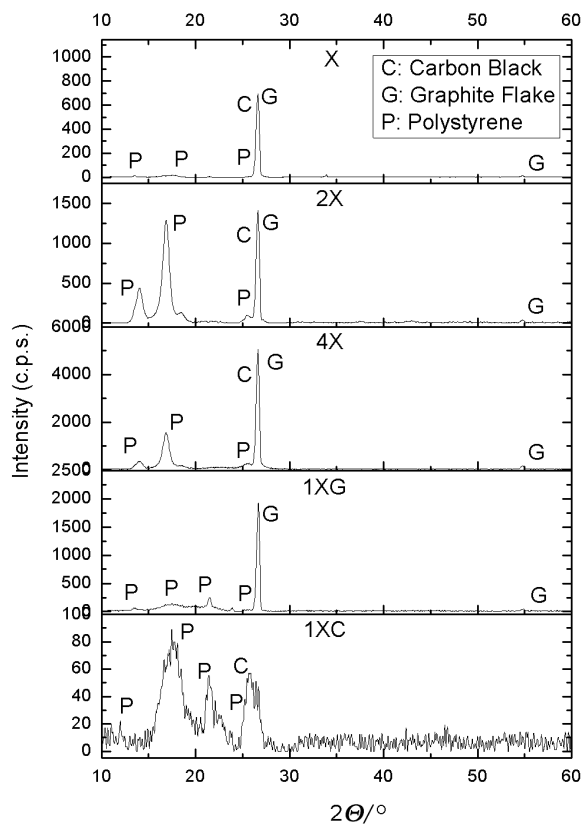

Figure 3: XRD patterns of the composite films on glass-fiber woven fabrics

Slika 3: Rentgenski posnetki kompozitnih tankih plasti na tkanini iz steklenih vlaknen

in this data. This pattern proves that polystyrene, graphite flakes and carbon-black powder are physically mixed in the composite structure as no structural or chemical change was observed. As expected, another observation of the XRD results showed a highly amorphous band of specimen 1XG and a highly crystalline structure of 1XG.

Microstructural properties of the composite films observed via SEM are shown in **Figure 4**. As can be seen from the micrographs, an efficient composite coating was prepared for the heating elements. It should be noted that the round areas were considered to be the bubbles left after the evaporation of the solvent due to an increase in the pore number and size against the relative solvent amount. It is also important to note here that the other areas on the micrographs were found to be polystyrene matrices encapsulating powder agglomerations.

The electrical behavior of the films was determined with the experimental setup (**Figure 2** for details) and the measured current data was used to calculate the resistance values according to the basic Ohm's law. The measured and calculated electrical properties are listed in **Table 2**. In the light of electrical measurements, the samples 1X, 1XG and 1XC were found to be highly insulating according to the resistance values. This is because the above particle/composite weight ratio of 0.6 is found to be lower than the intended structure. Percolation threshold is an important phenomenon, as reported in the research by S. Isaji et al.¹; however, there is no study of a polystyrene matrix filled with both graphite

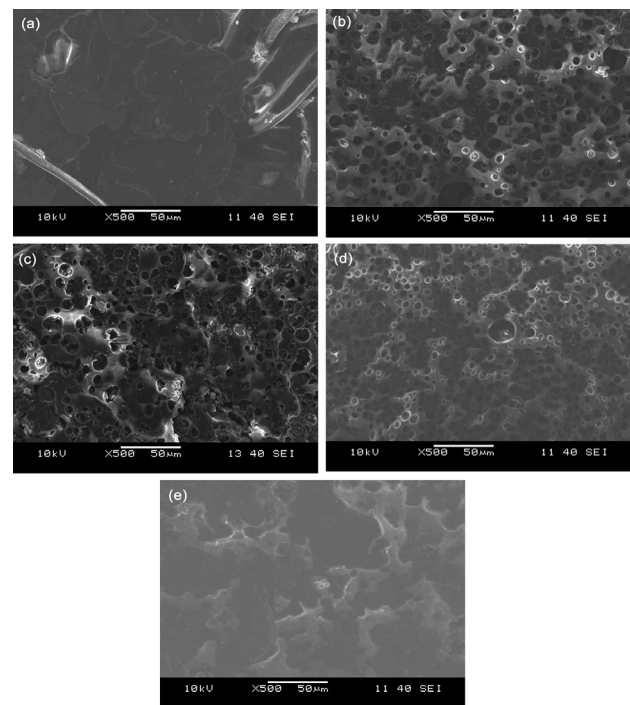

Figure 4: SEM micrographs of the composite films on glass-fiber woven fabrics including: a) 4X, b) 2X, c) X, d) 1XC, e) 1XG

Slika 4: SEM-posnetki kompozitne tanke plasti na tkanini iz steklenih vlaknen: a) 4X, b) 2X, c) X, d) 1XC, e) 1XG

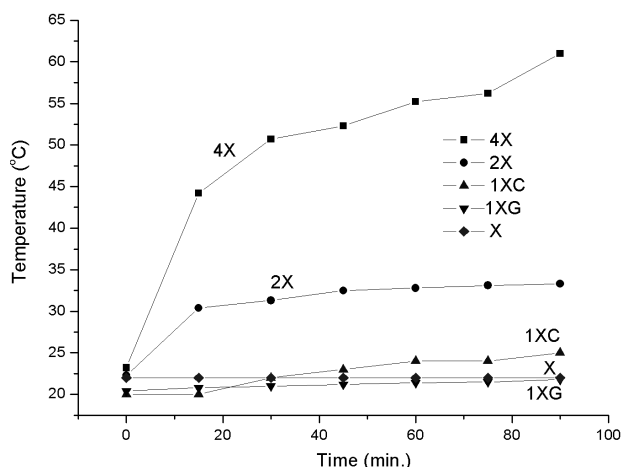

Figure 5: Time versus the obtained temperature results for the heating-element samples

Slika 5: Odvisnost časa in dosežene temperature pri ogrevanju vzorcev grelnih elementov

and carbon. In this study, the ratio of the powders loaded by us can be regarded as lower than the percolation threshold for the above samples. In this way, heating was obtained from these samples, as noted in **Figure 5**, which clarifies the variation of temperature with time and sample type. According to **Figure 5**, the samples such as 4X and 2X were determined to be good candidates for a plane heating that can reach the temperatures of 65 °C and 35 °C in 90 min, respectively.

Table 2: Electrical properties of the samples

Tabela 2: Električne lastnosti vzorcev

Sample code	DC voltage (V)	Current (mA)	Resistance (kW)
4X	24	9.611	2.49
2X	24	19.04	1.26
1X	24	0.25	96
1XC	24	0.02	1200
1XG	24	0.01	2400

It is interesting that the samples evaluated in this study were employed with a power supply unit of 24-V DC. As a result, the plane-heater coatings with large surfaces are applicable with 110-AC and 220-AC city voltages, as listed in **Table 2**. It also needs to be pointed out that this heating system does not emit any harmful gaseous or liquid impurities unlike the heating systems consuming fossil fuels. In addition, an easy layout and application efficiency make the system a good candidate heating device.

4 CONCLUSIONS

Graphite-flake carbon-black-reinforced polystyrene-matrix composite films were successfully deposited on glass-fiber woven substrates as plane heaters. Structural and microstructural results indicate a good compatibility between the powders and the matrix without any

chemical interaction among them and a good surface quality with a partial orientation of the reinforcement powders. Samples 4X and 2X were found to be good candidate materials for plane-heating systems or devices. The composite films are believed to be the new-generation heating elements due to being cost-effective, environmentally friendly and energy friendly. For these reasons, the composite films will start a new era in the heating sectors.

Acknowledgement

This study was financially supported by Ayçe Mühendislik Co. and the Turkish Ministry of Science, Industry and Technology with the project code 00360-STZ-2009-1.

5 REFERENCES

- S. Isaji, Y. Bin, M. Matsuo, Electrical conductivity and self-temperature-control heating properties of carbon nanotubes filled polyethylene films, *Polymer*, 50 (2009), 1046–1053
- D. Bloor, K. Donnelly, P. J. Hands, P. Laughlin, D. Lussey, A metal-polymer composite with unusual properties, *J. Phys. D: Appl. Phys.*, 38 (2005), 2851–2860
- P. V. Notingham, D. Panaitescu, H. Paven, M. Chipara, Some characteristics of conductive polymer composites containing stainless steel fibers, *Journal of Optoelectronics and Advanced Materials*, 6 (2004), 1081–1084
- T. Yamamoto, E. Kubota, A. Taniguchi, S. Dev, K. Tanaka, K. Osakada, Electrically conductive metal sulfide polymer composites prepared by using organosols of metal sulfides, *Chem. Mater.*, 4 (1992), 570–576
- S. Geethaa, K. Kannan, S. Kumarb, S. Meenakshia, M. T. Vijayana, D. C. Trivedia, Synergetic effect of conducting polymer composites reinforced E-glass fabric for the control of electromagnetic radiations, *Composites Science and Technology*, 70 (2010), 1017–1022
- A. Russameeden, J. Pumchusak, Preparation of fiber-reinforced electrically conducting polypropylene composites by wet-lay process for use as bipolar plate in a proton exchange membrane fuel cell, *Journal of Metals, Materials and Minerals*, 18 (2008), 121–124
- A. B. Kaiser, Y. W. Park, Current-voltage characteristics of conducting polymers and carbon nanotubes, *Synthetic Metals*, 152 (2005), 181–184
- K. R. Reddy, B. C. Sin, K. S. Ryu, J. C. Kim, H. Chung, Y. Lee, Conducting polymer functionalized multi-walled carbon nanotubes with noble metal nanoparticles: Synthesis, morphological characteristics and electrical properties, *Synthetic Metals*, 159 (2009), 595–603
- B. Chen, J. J. Liu, Y. Y. Sun, Study on thermal performance analysis method of direct-gain solar dwellings with floor heating, *Proceedings of ISES World Congress*, 3 (2009), 804–808
- R. Zeng, X. Wang, W. Xiao, Y. Zhang, Q. Zhang, H. Di, Thermal performance of phase change material energy storage floor for active solar water-heating system, *Front. Energy Power Eng. China*, 4 (2010) 2, 185–191
- Z. P. Song, R. Z. Wang, X. Q. Zhai, An experimental and simulation study on performance of solar-powered floor heating system, *Proceedings of ISES World Congress 2007*, 5 (2009), 2224–2228
- Z. G. Lin, S. Y. Zhang, X. Z. Fu, Y. Wang, Investigation of floor heating with thermal storage, *Journal of Central South University of Technology*, 13 (2006), 399–403