

Mehanski in elektronski merilnik hitrosti delcev v stroju za peskanje

A Mechanical and Electronic Measurement System for Particle Velocity Measurements in a Shotblasting Machine

Aleš Hribernik - Gorazd Bombek - Ivan Markočič

Osnovni problem merjenja hitrosti zrnc peska v peskalnem stroju je zelo velika abrazivnost peska in velika koncentracija prašnih delcev v zaprti testni napravi. Uporaba brezstičnih optičnih merilnih metod je zato pogosto nemogoča. Stične merilne metode so omejene na uporabo merilnikov, ki so zaščiteni z robustnimi oklepi. Kot alternativo robustnemu mehanskemu merilniku hitrosti zrnc peska smo razvili elektronski merilni sistem, ki ga odlikujeta dobra vodljivost vzdolž obeh prečnih osi curka peska in preprosta zgradba merilnega zaznavala, ki z uporabo cenjenih elementov dovoljuje pogosto zamenjavo in ne potrebuje robustnega oklepa. V prispevku so predstavljeni razvoj, delovanje in uporaba mehanskega in elektronskega merilnega sistema. Prikazani so rezultati meritev in podana je primerjava obeh metod z razpravo in sklepi.

© 2002 Strojniški vestnik. Vse pravice pridržane.

(Ključne besede: stroji za peskanje, meritve hitrosti, hitrosti delcev, merilniki mehanski, merilniki elektronski)

Two of the main problems for particle velocity measurement in a shotblasting machine are very abrasive shotblasting particles and a high concentration of dust within the closed testing chamber. The application of noncontacting optical methods is usually impossible; and robust shields protecting the sensors from abrasion have to be used for contacting velocity measurements. An electronic measurement system has been developed as an alternative to the robust, mechanical measurement device. This alternative electronic system has a simple construction and uses low-cost elements that can be replaced very quickly and, therefore, no robust shields are necessary. This enables very good mobility and positioning of the sensor along both axes in a cross-section plane of a particle stream. The development, operation and application of this mechanical and electronic particle velocity measurement system are described in this paper. Experimental results are presented, discussed and both methods are compared.

© 2002 Journal of Mechanical Engineering. All rights reserved.

(Keywords: shotblasting machines, velocity measurements, particle velocity, mechanical measuring devices, electronic measuring systems)

0 UVOD

Učinkovitost peskalnih naprav merimo s količino materiala, ki ga s postopkom odstranimo z nadzorne površine na enoto porabljene energije. Učinek peskanja je neposredno odvisen od hitrosti zrnc peska ob udarcu v nadzorno površino, saj odnašanje materiala zagotovi le dovolj velika kinetična energija zrnc. Zaradi tega je poznavanje hitrosti zrnc peska ob trku s peskano površino izrednega pomena za pravilno izbiro parametrov peskanja in za doseg kar največje učinkovitosti peskanja.

Pri merjenju hitrosti peska v peskalnem stroju smo se podali na razmeroma neraziskano področje. V literaturi ni zaslediti podobnih primerov, obstajajo pa določene podobnosti z načinom merjenja hitrosti izstrelkov v balistiki [1]. Ker so

0 INTRODUCTION

The efficiency of a shotblasting machine is measured by the quantity of material removed from a surface by a certain amount of energy. The effect of shotblasting depends on the velocity of the particles hitting the surface, since only those particles with enough kinetic energy can remove the material. A knowledge of particle velocity is, therefore, essential when selecting the optimum operation parameters of a shotblasting machine, thus ensuring the highest possible shotblasting efficiency.

Particle velocity measurements in shotblasting machines have been insufficiently investigated so far. No similar examples can be found in the literature; however, some similarities exist with velocity measurements in ballistics [1]. The application of noncontacting optical methods, commonly used for particle velocity measurements in sprays [2], has been impossible due to the

bile koncentracije prahu v preskuševalni napravi izredno velike, je bila uporaba brezstičnih optičnih metod [2] nemogoča. Zato smo razvili dve stični metodi: mehanski merilnik hitrosti z vrtečima obročema in elektronski merilni sistem z mikrofonskimi zaznavali, ki ju v nadaljevanju predstavljamo.

1 MEHANSKI MERILNIK HITOSTI Z VRTEČIMA SE PLOŠČAMA

Mehanski merilnik je prikazan na sliki 1. Sestavljata ga dve plošči na skupni gredi, ki jo poganja elektromotor. Pred ploščama je postavljena stena, ob katero udarja pesek iz peskalnega stroja. Na steni je izvrtina s premerom 10 mm, skozi katero pesek neovirano nadaljuje pot do prednje plošče, ki se vrti z izbrano vrtilno frekvenco. Tudi na prednji plošči je izvrtina s premerom 10 mm, ki se stožčasto (pod kotom 45°) širi od prednje proti zadnji strani. V trenutku, ko se izvrtini prekrijeta, lahko pesek nadaljuje pot proti zadnji plošči in udari ob papirnato tarčo, nalepljeno nanj. Kot φ razberemo s tarče in je kot med projekcijo izvrtine na prvi plošči in zadetki na tarči (slika 1). Hitrost zrnč peska pa nato izračunamo z izrazom:

$$w = \frac{l}{t} = \frac{\omega}{\varphi} \cdot \frac{180}{\pi} \cdot l \quad (1),$$

pri čemer je: l – razdalja med ploščama, ω - kotna hitrost plošč.

2 ELEKTRONSKI MERILNIK HITROSTI DELCEV Z MIKROFONSKIMI ZAZNAVALI

Elektronski merilnik (sl. 2a) sestavlja nosilo, na katerem sta dve mikrofonski zaznavali. Nosilo je prek prečne konzole pritrjeno na koordinatni podajalni sistem, ki omogoča navpično in vodoravno postavitvev zaznaval ter izbiro strmine nosila mikrofonskih zaznaval. Mikrofonsko zaznavalo sestavlja jeklen okrov z

high concentration of dust within the closed testing chamber. Two particle velocity measurement systems have, therefore, been developed: a mechanical measuring device using the principle of rotating discs, and an electronic system applying microphone sensors. This paper presents both systems.

1 MECHANICAL MEASURING DEVICE USING THE ROTATING DISCS PRINCIPLE

The measuring device is shown in Fig. 1. The discs on the common shaft are driven by an electric motor. The particles from the shotblasting turbine hit the screen that protects both discs. A 10-mm bore is made on the screen. The particles can continue their way unhindered through this bore to the front disc, which rotates at a known rotation speed. A 10-mm bore is made on the front disc, which is conically opened to the rear disc side. When both bores coincide the particles continue their way to the rear disc and hit the paper target that is fixed on it. The angle φ between the hits on the target and the projection of the front disc bore is then measured and used to calculate the velocity of the particles with the following equation:

where: l is the distance between the discs, and ω is the angular velocity of the discs.

2 AN ELECTRONIC PARTICLE VELOCITY MEASUREMENT SYSTEM WITH MICROPHONE SENSORS

Two specially designed microphone sensors are used, which are mounted on a longitudinal carrier (Fig 2a). The sensor's carrier is attached by a transverse cantilever to the coordinate tender system, which enables horizontal and vertical positioning of the sensors, and selection of the sensor carrier's inclination. A capacitor-type microphone encapsulated in a metal hous-

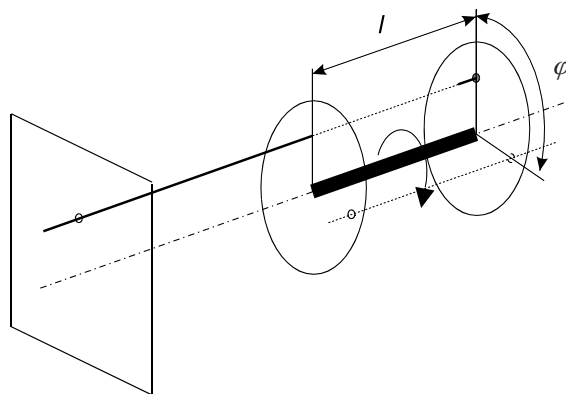

Sl. 1. Mehanski merilnik hitrosti zrnč peska
Fig. 1. Mechanical device for particle velocity measurements

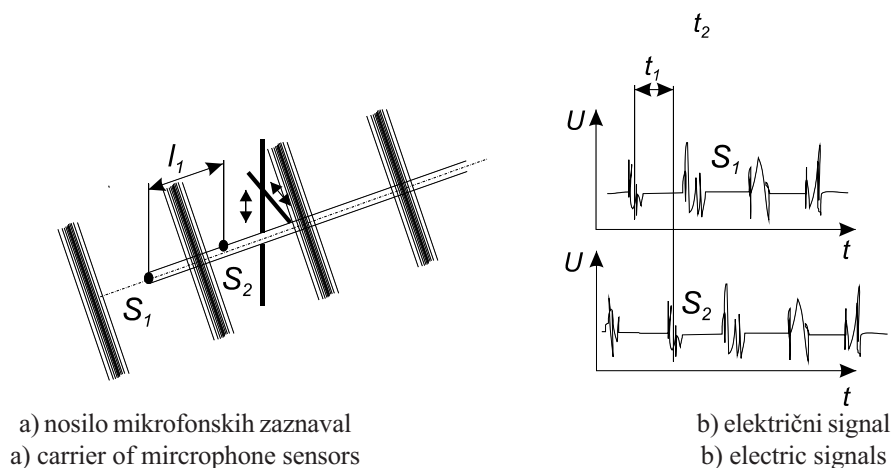

Sl. 2. Elektronski merilnik hitrosti zrn

Fig. 2. Electronic particle velocity measurement system

membrano, pod katero je nameščen kondenzatorski mikrofonski zaznavalo S1 je zatisnjeno neposredno v jekleno cev nosila, zaznavalo S2 pa je bočno pritrjeno na nosilo. Udarec na površino jeklene membrane povzroči nihanje membrane in se prenese na mikrofonski zaznavalo, kar povzroči naglo spremembo signala. Pri uporabi elektronskega merilnika izkoriščamo pulzno delovanje peskalne turbine. V nasprotju z običajno centrifugalno radialno črpalko, ki jo tekočina polni po celotnem notranjem obodu, poteka polnjenje kanalov med lopaticami peskalne turbine le na določenem delu notranjega oboda. Zato izmetavajo lopatice pesek le v izbranem delu zunanega oboda, neposredno v peskalno napravo. Pri tem je tok peska v neki opazovani točki izrazito ponavljajoč, prihaja v obliki zgoščenih paketov zrn peska s frekvenco, ki je enaka zmnožku vrtilne frekvence rotorja turbine in števila lopatic turbine. Tak je tudi signal, ki ga zaznata mikrofonski zaznavala (sl. 2b). Zaradi vzdolžnega odmika med zaznavali sta signala časovno premaknjena. Pri tem je čas zakasnitve sorazmeren razmerju hitrosti zrn in razdalje med zaznavali. Torej je mogoče hitrost zrn peska preprosto izračunati z izrazom:

$$w = \frac{l_1}{t_1} \quad (2).$$

2.1 Zgradba mikrofonkega zaznavala

Mikrofonsko zaznavalo (sl. 3) sestavlja teflonska puša, v katero je privita jeklena membrana. Tik pod membrano je nameščen kondenzatorski mikrofonski zaznavalo, ki se tesno prilega teflonski puši. Med membrano in teflonsko pušo je vstavljena ploščica iz mehke silikonske gume. Teflonska puša je zatisnjena v jekleno pušo, ki je okrov zaznavala in prek katere je zaznavalo pritrjeno na nosilo.

Razvoj mikrofonkega zaznavala je potekal v več korakih. Osnovno vodilo razvoja je bilo

ing and placed under the metal membrane forms the microphone sensor. The sensor S1 is impressed directly into the front opening of the sensor's carrier, while the S2 sensor is mounted on the upper side of the carrier. The vibration of the membrane resulting from the impact of particles is transmitted to the microphone which signals any sudden changes (a sudden change of microphone's electric signal occurs). The electric measuring system makes use of a pulsatile shotblasting turbine operation. Only partial admission is used by the shotblasting turbine, in contrast to the radial pump where admission takes place over the whole inner circumference. The turbine blades eject the particles at the selected position on the outer circumference, directly into the shotblasting machine. The particle flow is, therefore, pulsatile: it rises in waves of high and low particle concentrations with a frequency that is equal to the product of the rotor's rotational speed and the number of blades. The signals from both sensors, S1 and S2 (Fig. 2b), which are phased over a particular time interval are similar to the particle flow. This time interval (time delay) is inversely proportional to the longitudinal distance between the sensors, and it is proportioned according to the velocity of the particles. The particle velocity can, therefore, be calculated as:

2.1 Microphone sensor

A microphone sensor is shown in Fig. 3. It is made of a plastic tube, into the top of which a metal membrane is screwed. A capacitor-type microphone fastened in the plastic tube is placed under the membrane. A washer made of soft silicone rubber is placed between the plastic tube and the metal membrane. This plastic tube is impressed into the metal housing, which is then fixed to the sensor's carrier (Fig. 2a).

The development of this microphone sensor was performed over a number of successive steps. The basic

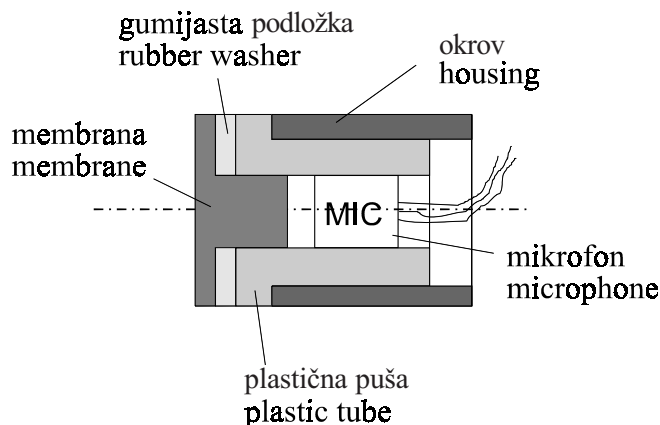

Sl. 3. Mikrofonsko zaznavalo
Fig. 3. Microphone sensor

doseči čim močnejši signal na enoto obremenitve membrane ob hkratnem dobrem dušenju lastnih nihanj in nihanj, ki so posledica udarcev v bok nosila in pomenijo motnjo. Preskusili smo tri tipe zaznaval A, B in C. Zaznavalo tipa A je sestavljeno iz jeklene puše, v katero je zatisnjen mikrofon, vstavljen v teflonski obroč. Membrana nad mikrofonom debeline 4 mm je pritrjena na jekleno pušo. Na sliki 4 je prikazan odziv zaznavala na udarec, ki ga povzroči trk jeklene kroglice mase 1,5 g s hitrostjo 0,3 m/s (učinek trka ustreza trku povprečno velikega zrnca peska s hitrostjo 60 m/s). Ugotovimo lahko, da je sprememba signala

task was to increase the sensitivity of the microphone sensor (as high an output signal as possible per unit of membrane load), and to reduce the oscillations caused by the resonance in the system's natural frequency domain or induced by the side impact of the particles. Three different types of sensor – Types A, B and C – were tested. The type-A sensor was made up of a metal housing covered with a metal membrane. The microphone was placed into this housing and fixed by a plastic ring. The membrane was 4-mm thick. The impulse response for the type-A sensor is shown in Fig. 4. The impulse input force was applied to the middle of the membrane by the impact ball. The ball's mass was 1.5 g, and the speed

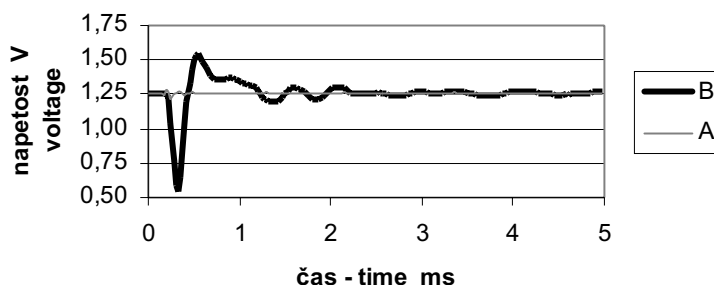

Sl. 4. Odziv zaznavala na udarec (A – membrana zatisnjena v jekleno pušo, B – membrana zatisnjena v silikonsko pušo)

Fig. 4. Impulse response of sensor (A – membrane impressed directly into the metal housing, B – membrane impressed into the plastic tube)

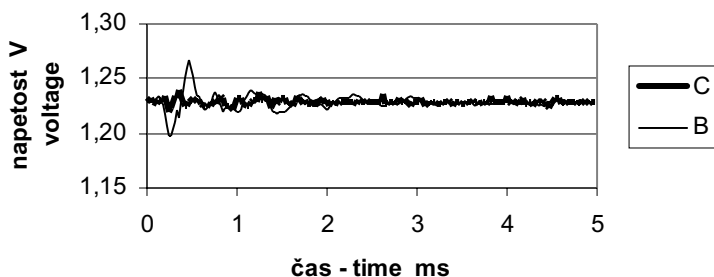

Sl. 5. Odziv zaznavala na bočni udarec (B - membrana zatisnjena v silikonsko pušo brez podloge; C - membrana zatisnjena v silikonsko pušo s podlogo)

Fig. 5. Sensor response on the side impact (B – membrane impressed into the plastic tube without rubber washer; C - membrane impressed into the plastic tube with rubber washer)

majhna, reda velikosti 50 mV, kar je le 4% srednje vrednosti signala in ne zadošča za izvedbo meritev. V primeru zaznavala tipa B je amplituda odziva neprimerno večja. Največja sprememba signala doseže kar 60 % srednje vrednosti signala. Tako veliko amplitudo odziva smo dosegli s spremenjenim vpetjem membrane. Da bi kar se da zmanjšali togost vpetja, smo membrano zatisnili v silikonsko pušo, ki je bila vstavljena v jeklen okrov zaznavala, kakor to prikazuje slika 3. Slaba stran tega vpetja pa so razmeroma velike motnje, ki jih povzročajo udarci ob bok zaznavala (sl. 5). Te nam je uspelo zmanjšati tako, da smo med jekleno membrano in teflonsko pušo vstavili mehko silikonsko gumo (senzor tipa C - sl. 3), s katero nam je uspelo povečati dušenje sistema in zmanjšati motnje (sl. 5). S tem smo sicer zmanjšali amplitudo odziva sistema (sl. 6), ki pa je še vedno dovolj velika (20 do 30 % srednje vrednosti signala), da lahko zaznavalo uporabimo za meritve hitrosti. Jeklena membrana ima dvojno nalogo. Ena je, da zaščiti mikrofonski pred neposrednim vplivom peska, druga pa je, da ob udarcu peska odda zvok, ki ga zazna mikrofonski. Pri tem je zvočni tlak neposredno odvisen od debeline membrane. Ker pa je membrana med delovanjem izpostavljena intenzivni abraziji (hitrost odnašanja materiala 1,5 mm/uro), je treba najti kompromis med amplitudo odziva in dobo trajanja zaznavala. Preskusili smo tri membrane debelin 2 mm, 3,5 mm in 5 mm. Vpliv debeline membrane na odziv sistema prikazuje slika 6. S povečevanjem debeline amplituda odziva slabi in znaša pri debelini 5 mm le še 10 % povprečne vrednosti signala. Zato smo se odločili za membrano debeline 3,5 mm. Ta zagotavlja vsaj 90 minutno dobo trajanja zaznavala in ima tudi pri začetni debelini amplitudo odziva enako 20 % povprečne vrednosti signala.

of the ball was 0.3 m/s (the effect of the ball's impact is similar to the impact of an average shotblasting particle with a velocity of 60 m/s). The change of the signal was low, as shown in Fig. 4. It did not exceed 50 mV, which is less than 4% of the mean magnitude of the signal. This is far too small for the application of a type-A sensor for particle velocity measurements. The change of the signal was much higher for the type-B sensor (Fig. 4). The maximal signal change was 60 % of the mean signal magnitude. This was achieved by modifying the membrane fixture. In order to reduce the stiffness of the membrane's fixture, the membrane was screwed into the plastic tube, which was then fixed into the metal housing (see Fig. 3). The weakness of this type of sensor is its high sensitivity to side impacts (undesired disturbances, Fig. 5). This problem was solved by the application of a soft silicone-rubber washer placed between the metal membrane and the plastic tube (Fig. 3). The damping of the membrane's vibrations was increased and the sensitivity to side impacts was reduced by the application of a soft rubber washer. Unfortunately, this modification reduced the overall sensor sensitivity as well (Fig. 6). However, the signal alteration remained high enough (20–30 % of the mean signal magnitude) to carry out the particle velocity measurement. The metal membrane placed in front of the microphone performs a dual role. First, to protect the microphone from the direct impact of abrasive particles. Second, as a source of sound that is sensed by the microphone. The intensity of the sound pressure depends on the membrane thickness. Since the amount of material removed from the membrane surface during measuring is very high (approximately 1.5 mm/hour), a compromise had to be found between the signal intensity and the sensor lifetime. Three membranes with thickness of 2 mm, 3.5 mm and 5 mm were, therefore, tested. The influence of the membrane thickness on the sensor-impulse response is shown in Fig. 6. The intensity of the signal change was reduced by increasing the membrane thickness. A signal from the 5-mm membrane was too low and, since the lifetime of a 2-mm-membrane sensor would be less than 45 minutes, a 3.5-mm membrane was chosen. The lifetime of this membrane is at least 90 minutes, and the change of the signal with each impulse impact is 20% of the mean signal magnitude of the initial membrane thickness.

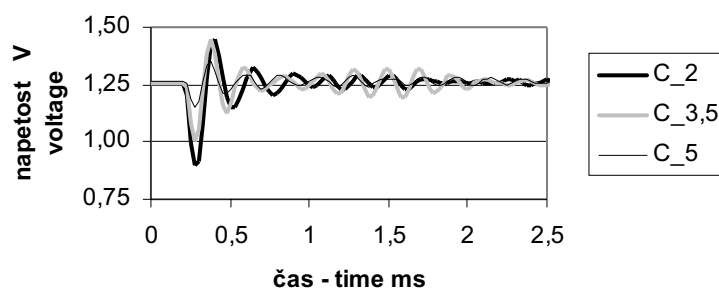

Sl. 6. Vpliv debeline membrane na odziv zaznavala tipa C
Fig. 6. The influence of the membrane thickness on the response of type C sensor

2.2 Sistem za zbiranje in analizo podatkov

Uporaba mikrofonskih zaznaval zahteva ustrezno opremo tako za zbiranje podatkov kakor tudi za njihovo obdelavo. Uporabili smo računalniško podprt sistem, ki ga sestavlja prenosni osebni računalnik (Celeron 1000 MHz, 256 MB RAM) z večnamensko kartico DaqCARD 6062 (format PCMCIA). Fizično smo električne povezave izvedli tako, da smo uporabili sistem za pripravo signalov SCXI. Večfunkcijska kartica, sistem za pripravo signalov in programska oprema so izdelek podjetja National Instruments.

Analogne vhodne signale smo pripeljali v modul SCXI-1140. Signale smo vezali diferencialno. Za napajanje mikrofonov smo uporabili modul SCXI-1124. Povezavo smo izvedli tako, da smo izenačili potencialne vse negativnih potencialov, analogne zemlje in potenciala okrova. Poleg tega smo na maso vezali tudi kovinsko ogrodje in tako dobili Faradejevo kletko ter tako zmanjšali motnje, ki so posledica elektrostatičnega delovanja zrnca peska, ki udarjajo ob stene preskusne komore.

Za zbiranje podatkov in njihovo obdelavo smo uporabili program LabVIEW. Ta program omogoča nadzor nad delovanjem večnamenske kartice (zajemanje električnih signalov in napajanje mikrofonov), pa tudi shranjevanjem in obdelavo podatkov.

3 MERITVE IN REZULTATI

Meritve smo izvajali v sredini curka peska na oddaljenosti 650 mm od vrha lopatic rotorja turbine. Os merilnika smo postavili vzporedno s smerjo zrnca peska. Zato smo za vsako posamezno turbino pred začetkom meritev posneli t.i. sliko curka. V ta namen smo v testno komoro na oddaljenosti 1100 mm od turbine postavili zaslon, na katerem je bila pritrjena tarča. Pred zaslon smo postavili odklonsko mrežico. Med peskanjem zaslona so na tarči ostala mesta v senci odklonske mrežice nepoškodovana. Na podlagi navpičnega odmika med točko na odklonski mrežici in njej pripadajočo senco ter razdaljo med točko in zaslonom smo nato ugotavljali kot poti zrnca proti vzdolžni smeri. Analizirali smo delovanje štirih različnih turbin. Za vsako smo izvedli večje število meritev z mehanskim in elektronskim merilnikom hitrosti v eni sami točki curka. Pri tem smo meritve ponavljali v isti točki vsaj trikrat, točko meritve pa smo izbrali tako, da so bile razmere (smer curka, oddaljenost merilnika od turbine itn.) za vse turbine približno enake. V nadaljevanju bomo predstavili rezultate, izmerjene s prototipno izvedbo turbine z osmimi naprej ukrivljenimi lopaticami (G 300U) pri vrtilni frekvenci rotorja 50 Hz.

2.2 Data acquisition and data-analysis system

Data acquisition and a data-analysis system are required for the particle velocity measurements using microphone sensors (electronic system). A computer-aided measuring system was used, which incorporates a personal computer (Celeron 1000 MHz, 256 MB RAM) and a multifunction card (DaqCARD 6062, format PCMCIA). The electric signals were conditioned by an SCXI data-conditioning system. The multifunction card, data-acquisition system and application software are all products from National Instruments.

The differential analog input signals were fed to the SCXI-1140 module. The microphones were supplied with a constant DC voltage source from the SCXI-1124 module. The sensor wiring was made by a common negative potential, which was connected to the analog ground with the SCXI chassis and the sensor's carrier construction. A Faraday cage was formed in this way, and the disturbances caused by the large amount of electrostatic noise (resulting from particles hitting the walls of the testing chamber) were reduced.

LabVIEW software was used to build the computer applications for the data acquisition and the data analyses. These applications are used to control the operation of the multifunction card (data acquisition, DC voltage output for microphones) and for data logging and post-processing of the data.

3 MEASUREMENTS AND RESULTS

The measurements were carried out in the centre of the particles' stream, 650 mm from the tip of the shotblasting turbine's blade. The longitudinal sensor axis was set parallel to the particle trajectories. A so-called stream image was, therefore, determined first showing the particle trajectories. A paper target was fixed on the vertical screen 1100 mm away from the turbine. An inclination mesh was placed in front of the screen and the turbine was allowed to run for a short period. The target in the shadow of the inclination mesh remained undamaged. The flow angle of particles within the stream intersected using the inclination mesh was determined based on the differences between the coordinates of the particular point on the mesh and the coordinates of its matching point on the target. The operation of four different turbines was analysed. Several measurements were performed using both methods, all in just one central point of the particle stream. The flow conditions were similar for all turbines. Each measurement was repeated at least three times. The results for the prototype G300U turbine with eight forward curved blades measured at 3000 revolutions per minute (50 Hz) are presented in more in detail.

3.1 Rezultati meritev hitrosti z mehanskim merilnikom

Merilnik smo postavili nad ravnino osi turbine, v višino, pri kateri je bila smer zrnc $+6,25^\circ$ nasproti vodoravnici. Sredina zaslonke se je ujemala s sredino curka. Izvedli smo tri zaporedne meritve. Vsaka meritev je bila sestavljena iz dveh faz. V prvi fazi smo obstreljevali tarčo med mirovanjem plošč. Tako smo določili projekcijo izvrtine prednje plošče na tarči, prilepljeni na zadnji obroč. Nato smo z elektromotorjem plošči zavrteli in pri ustaljenih vrtljajih obstreljevali tarčo v kratkem presledku. Rezultate meritve, t.j. položaj zadetkov na tarči, smo določili z odbiranjem, pri čemer je bila delitev lestvice na tarči 1° . Rezultat so zbrani v preglednici 1.

Kakor je razvidno iz preglednice 1, je ujemanje izmerjenih srednjih hitrosti zrnc zelo dobro; odstopki ne presežejo 1,3 m/s. Vendar je merilna negotovost precej večja. Vzrok za to je precej širok pas zadetkov tarče v območju $\pm 10^\circ$. Tak raztros je delno posledica širine odprtine na prednjem obroču ($\varnothing=10$ mm), ki tudi pri mirovanju plošč povzroči raztros v območju $\pm 5^\circ$. Dodaten prispevek k raztrosu pa prinese neenakost hitrosti posameznih zrnc peska. Delno je ta neenakost opazna že v samem toku zrnc pred merilnikom, dodatno pa k njej prispevajo medsebojni trki zrnc, ki jih povzročajo od merilnika odbita zrnca na vstopu skozi zaslonko in pri prehodu skozi odprtino prednje plošče.

3.1 Results of the mechanical measuring device

The measuring axis of the mechanical measuring device was placed above the zero plane defined by the turbine axis, and the particle velocity was inclined by 6.25 degrees from the horizontal at this particular position. The orifice (front bore) was in line with the centre of the particle stream. Three successive measurements were carried out. Each measurement was performed in two stages. In the first stage the disks and the target were at a standstill, and they were briefly exposed to the particles. The projection of the front disk bore on the target was determined in this way. In the second stage the discs were driven by an electric motor. The target was briefly exposed to the particles again at a constant rotational speed. The result of the measurement, i.e. the angle between the hits into the target when held still and the hits into the rotating target, was read from the scale that was printed on the table with a 1 degree increment. The results are shown in Table 1.

The measured particle velocities agree well, and as can be seen from Table 1 the deviation from the average value is less than 1.3 m/s. However, the measurement uncertainty is much higher due to the large scatter of the hits on the target. The scatter of the hits was ± 10 degrees. One of the reasons for this scatter is the wide bore ($\varnothing=10$ mm) on the front disc, which resulted in ± 5 degrees scatter of hits onto the target held still (first step of the velocity measurement). The unequal speed of the particles within the stream expanded the scatter even more when the disc and target were rotated. The particles already had a different velocity ahead of the measuring plane. These speed differences within the measuring device increase due to the collisions between the particles when passing the orifice in the screen and in the front disc.

Preglednica 1. Rezultati meritve hitrosti zrnc peska z mehanskim merilnikom za turbino G300U

Table 1. Results of the particle velocity measurement of the G300U shotblasting turbine using a mechanical measuring device

Meritev Measurement	Vrtilna hitrost Rotational speed min ⁻¹	Kot Angle φ^0	Hitrost zrnc Particle velocity m/s	Standardna merilna negotovost Standard measurement uncertainty m/s
1	7650	155	73,4	+3,1
2	7780	153	75,7	+3,2
3	7720	155	74,1	+3,1
Povprečna vrednost Average value			74,4	$\pm 3,1$

3.2 Rezultati meritev hitrosti z elektronskim merilnikom

Ker imajo mikrofoni frekvenčni odziv prilagojen zvoku, ki ga lahko zaznava človeško uho (do 17 kHz), smo se odločili za približno 2-krat višjo frekvenco zajemanja - 40000 Hz. Signal, zajet s to frekvenco, lahko kasneje analiziramo in prepoznamo frekvence do 20000 Hz (po Nyquistovem teoremu) [3]. Odločili smo se, da bomo zajeli 200000 merilnih točk na kanal, kar ustreza času 5 sekund. Meritev smo izvedli tako, da smo ob zagonu turbine

3.2 Results of the electronic measurement system

The frequency response of the applied standard microphones is adjusted to the audible sound of the human ear (up to 17 kHz). Therefore, the signals were acquired using a 40-kHz acquisition frequency. According to the Nyquist theorem [3], the discrete signal acquired using this frequency can be post-analysed and frequencies up to 20 kHz can be recognised. The amount of acquired data was 200,000 per channel. This corresponds to a period of 5 seconds. A screen placed in front of the

elektronski merilnik zastrli z zastorom, postavljenim 300 mm pred prvo mikrofonsko zaznavalo. Ko so se razmere v turbini ustalile, smo zaslon umaknili in zajeli signale.

Slika 7 prikazuje zajeta neobdelana signala. Zaradi velike gostote zapisa je slika nepregledna, vidi pa se trenutek, ko je pesek začel udarjati po mikrofoni.

Da bi lahko zajeta signala uporabili za določitev hitrosti zrnec peska, smo v programskem okolju LabVIEW izdelali poseben algoritem. Pri tem smo uporabili standardna programska orodja, ki jih programsko okolje ponuja. Z algoritmom obdelamo signal v dveh korakih. V prvem koraku s frekvenčno analizo z uporabo hitre Fourierjevo preslikavo (HFP - FFT) [4] določimo diskretni frekvenčni spekter diskretnega (digitaliziranega) signala. Frekvenčni spekter pokaže, katere frekvence in s kakšno amplitudo se pojavljajo v signalu. Frekvenčni spekter signala prvega zaznavala je prikazan na sliki 8. Opazimo, da obstajata dve frekvenčni območji večje intenzivnosti. Frekvenčno območje 3500 Hz do 7000 Hz je posledica lastnih nihanj sistema. Bolj zanimivo je območje med 0 in 1000 Hz, ki je prikazano na sliki 9. Ugotovimo, da se prva izrazita amplituda

sensors was used to cover the sensors when the turbine was started up and until steady-state operation was achieved. At that moment the screen was removed.

The raw, acquired signals are shown in Fig. 7. The diagram lacks clarity because of the high density of the recorded data, although the moment when the first particles hit the membrane of the sensor is clearly recognisable.

In order to use the signals for particle velocity determination a special algorithm was made in the LabVIEW programming language. Standard LabVIEW program routines were used. The signals were processed in two steps using the algorithm. In the first the discrete Fourier frequency spectrum from the digitised input signal was determined by the application of the fast Fourier transform algorithm [4]. The frequency spectrum shows significant frequency components. The frequency spectrum of the signal from the first sensor (S1) is shown in Fig. 8. There are two frequency domains of higher intensity. The frequency domain between 3500 and 7000 Hz corresponds to the natural frequencies of the coordinate tender system and sensors. More important is the domain between 0 and 1000 Hz, shown in Fig. 9. The first significant frequency is 50 Hz, and this corresponds to the rota-

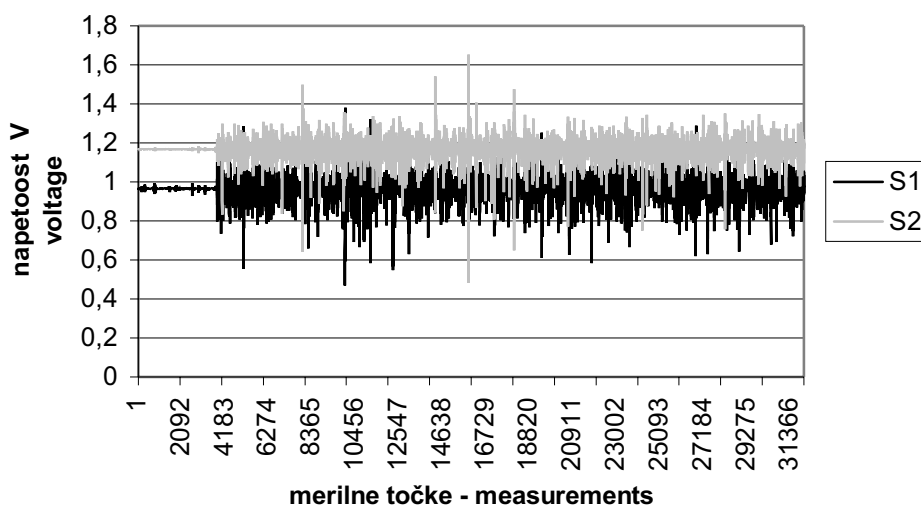

Sl. 7. Signala z zaznaval S1 in S2 posneta s frekvenco 40.000 Hz
Fig. 7. Signals from sensors S1 and S2 recorded by 40,000 Hz

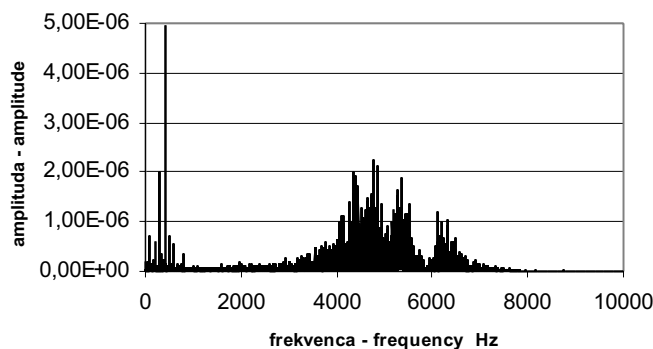

Sl. 8. Frekvenčni spekter signala z zaznavala S1
Fig. 8. Frequency spectre of a signal from sensor S1

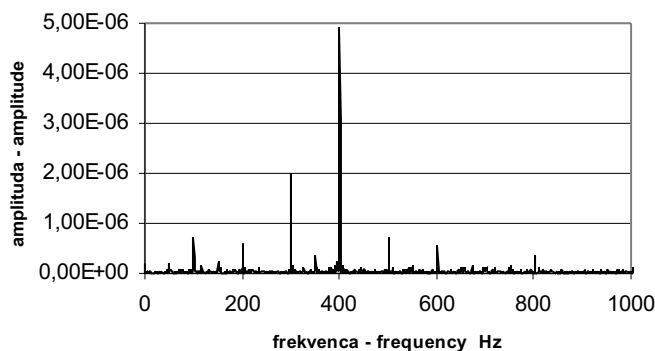

Sl. 9. Frekvenčni spekter v območju 0-1000Hz – signal z zaznavala S1
Fig. 9. Frequency spectre of 0-1000 Hz domain - signal from sensor S1

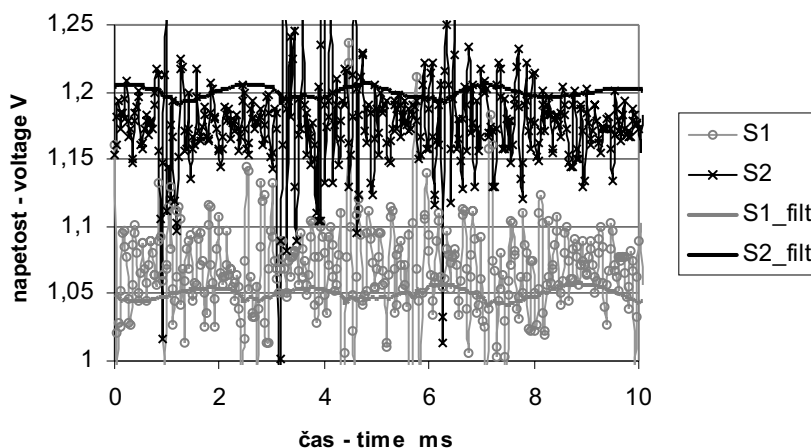

Sl. 10. Primerjava osnovnih in filtriranih signalov z zaznaval S1 in S2
Fig. 10. Comparison of non-filtered and filtered signals from sensors S1 and S2

pojavi pri 50 Hz, kar ustreza vrtilni frekvenci turbine. Z enako ali višjo amplitudo se nato pojavijo tudi vse njene višje harmonske. Najizrazitejša amplituda se pojavi pri 400 Hz in ustreza frekvenci vzpodbude, ki je zmnožek vrtilne frekvence turbine in števila lopatic (50 Hz, 8 lopatic). Veliko število izrazitih nižjih in višjih harmonskih napoveduje, da je delovanje prototipne turbine še precej neubrano.

Frekvenčni analizi sledi naslednji korak, to je filtriranje signala. Namen filtriranja je, da iz osnovnega signala izluščimo tisti del, ki je posledica vzbujanja sistema z osnovno frekvenco 400 Hz, s katero lopatice turbine izmetavajo pesek. Uporabili smo ozkopasovni filter z območjem 350 do 450 Hz. Zaradi nadaljnje obdelave mora biti filtriran signal čim bolj gladek prehod v območje zavrnitve pa čim bolj strm. To smo dosegli z uporabo digitalnega Čebišovovega filtra II [5]. Ta ima ravno karakteristiko v frekvenčnem območju prepuščanja signala in izredno strm, odsekan prehod v območje zavrnitve. Na sliki 10 sta prikazana osnovna in filtrirana signala z zaznaval S1 in S2. V obeh primerih je rezultat filtriranja razmeroma gladka krivulja z dovolj izrazitimi ekstremi, ki nam jih je uspelo lokalizirati z uporabo algoritma za iskanje dolov in vrhov diskretnega signala. Ker lokalni doli filtriranega signala ustrezajo naglim spremembam osnovnega

tional frequency of the turbine. All higher harmonics are presented with the same or higher intensity. The most significant frequency is 400 Hz, and this corresponds to the excitation frequency that is the product of the number of turbine blades and turbine rotational frequency (8 blades, 50 Hz). The very large number of distinctive higher and lower harmonics show evidence of a poorly tuned turbine.

The next step was signal filtering. The intention was to isolate that part of the signal which corresponds to the excitation frequency (400 Hz), at which the blades eject the particles, from the raw signal. A bandpass filter was used with a bandpass between 350 Hz and 450 Hz. The Chebyshev II design digital filter was applied [5]. These filters are maximally flat in the passband and give a sharp transition between the passband and the stop band. The filtered signal is, therefore, smooth, which is necessary for subsequent signal processing. The filtered and non-filtered signals from sensors S1 and S2 are presented in Fig. 10. The filtered curves are smooth with distinctive extremes. The extremes are localised by the algorithm for the determination of the maximum and minimum values of the discrete signal. The local minimum of the filtered signal corresponds to the rapid change of the non-filtered signal (caused by the impact of the particles on the membrane) as can be seen in Fig. 10. The time delay between the impacts on the first and

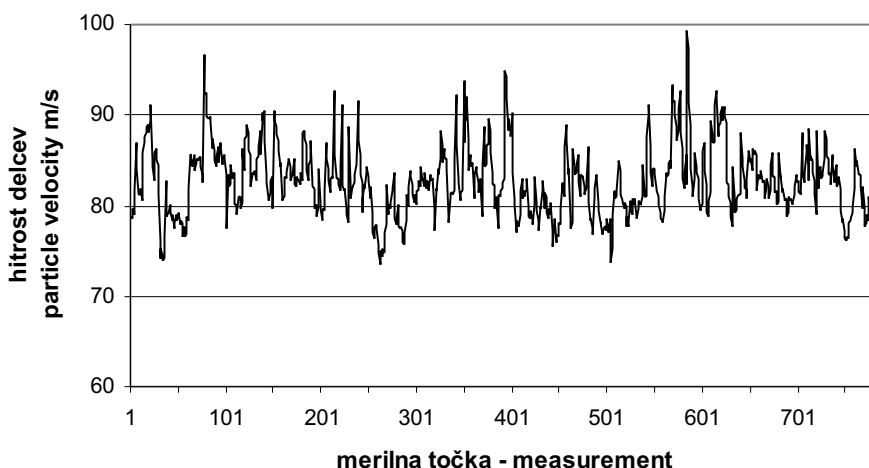

Sl. 11. Diagram izračunanih hitrosti v merilnih točkah 1 do 800

Fig. 11. Diagram of calculated particle velocities of measurements 1 to 800

signala (padec napetosti – slika 10), ki jih povzročajo udarci peska ob membrano zaznavala, smo časovni premik med udarci v prvo in drugo zaznavalo določili na podlagi časovnih razlik med lokalnimi doli obeh filtriranih signalov. Časovni premik smo nato uporabili v izrazu (2) in izračunali hitrost potovanja zrnca peska med zaznavali 1 in 2. Končni rezultat obdelave obeh signalov v območju dolžine 2 s prikazuje slika 11. Razvidno je, da je raztros hitrosti precej velik. Povprečna vrednost izračunane hitrosti je 82,6 m/s, standardna deviacija pa znaša 3,87 m/s. Zaradi velikega števila meritev je standardna merilna negotovost majhna in je 0,15 m/s. V primerjavi z izmerjeno hitrostjo z mehanskim merilnikom je hitrost večja za 11% (8,2 m/s). Enako velike razlike so se pokazale tudi pri meritvah drugih turbin, ki se od obravnavane razlikujejo po obliki in številu lopatic. Zato lahko sklepamo, da na nastanek teh razlik ne vpliva netočnost merilne metode, pač pa so posledica različne zasnove obeh merilnikov. Mehanski merilnik izmeri srednjo hitrost zrnca, medtem ko v primeru mikrofonskega merilnika izmerimo hitrost najhitrejših delcev, ki prvi udarijo ob membrano in povzročijo njeno nihanje in s tem naglo spremembo signala. Poskusili smo najti tudi pojasnilo za velik raztros izmerjenih hitrosti. Nanj gotovo vpliva različna zrnavost peska ($\varnothing = 0,05$ do 1 mm), kar povzroča različno intenzivne udarce ob membrano zaznavala s tem pa bolj in manj izrazite spremembe osnovnega signala in premik lokalnih dolov v filtriranem signalu. Dodatno prinese k večjemu raztrosu tudi neubranost delovanje turbine, ki je posledica nenatančnosti pri izdelavi (litju) ležišč lopatic v rotorju, montaže lopatic in predvsem različne obrabe lopatic. Da bi določili stopnjo neubranosti, smo analizirali filtriran signal s prvega zaznavala. Ugotavljali smo dolžino premika med zaporednimi udarci ob membrano. Vsaki od osmih lopatic smo poiskali zakasnitev glede na prejšnjo lopatico. To smo naredili tako, da smo matriko, ki je vsebovala

second sensor can, therefore, be determined from the local phase between both filtered signals. This time interval is then used in equation (2), and the particle velocity between the sensors S1 and S2 is calculated. The final result of processing a 2-second period of the raw signals is shown in Fig. 11. Velocity scatter is relatively high. The average particle velocity is 82.6 m/s and the RMS (Root Mean Square) is 3.87 m/s. The standard measurement uncertainty is 0.15 m/s. This value is low due to the large number of measurements. The average measured velocity is 8.2 m/s, i.e. 11 % higher than the particle velocity measured by the mechanical device. It is interesting that similar differences were observed for other turbines as well, although they have different designs and a different number and curvature of blades. It may be assumed, therefore, that this difference is not the result of a measurement error, but is conditioned by the different measurement approaches applied in both velocity measurement methods. The average particle velocity is measured by a mechanical device, whilst the maximum particle speed is measured by an electronic system that reacts to the first hit of the membranes caused by the fastest particles. An explanation for the high velocity scatter was also found. The composition of shotblasting particles is not uniform. The particle diameter may vary from 0.05 mm to 1 mm. This causes a very high variation in the particle's impact force intensity and, therefore, causes less distinctive magnitude changes in the measured signal and some phase shift of the filtered signal. The next reason for the large scatter of the measured velocities is a poorly tuned, prototype turbine. This is primarily due to different degrees of turbine-blade wear and non-optimised matching of the cast blades with the grooves of the cast rotor ring. An attempt was made, therefore, to establish the degree of non-tunableness in the shotblasting turbine's operation. The filtered signal from the first sensor was analysed. The time delays between the successive membrane hits were determined first. The results were then split into eight rows, each of them corresponds

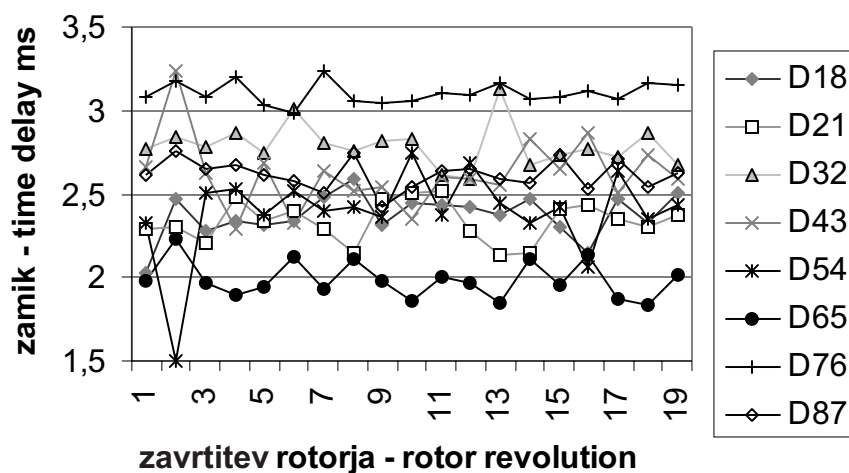

Fig. 12. Time delays between the particle ejection from individual blades

zakasnitve med udarci v prvi mikrofoni, razdelili na 8 stolpcev. Rezultat prikazuje slika 12. Opazimo, da je povprečna dolžina premika 2,53 ms, kar dobro ustreza frekvenci vzbujanja 400 Hz. Močno izstopata krivulji $\Delta 65$ in $\Delta 76$. To pomeni da, izmetavanje peska z lopatice 6 prehiteva, zaradi česar se skrajša korak med udarci z lopatic 5 in 6 ter podaljša korak med udarci z lopatic 6 in 7. Podobno, vendar precej manj, odstopata tudi krivulji $\Delta 12$ in $\Delta 32$, kar kaže na prehitevanje izmetavanja peska z lopatice 2. Ugotovitve, ki smo jih dobili z analizo signala, so se potrdile pri pregledu rotorja. Izkazalo se je, da je obraba dveh simetrično postavljenih lopatic precej večja od obrabe preostalih lopatic. Povečana obraba je bila posledica različnih materialov, iz katerih so bile preskusno izdelane lopatice v prototipni turbini.

4 SKLEPI

V prispevku sta prikazana dva merilnika, ki omogočata merjenje hitrosti delcev v stroju za peskanje. Merilnik z rotirajočima ploščama je robusten in omogoča merjenje hitrosti delcev le v majhnem številu točk. Njegova največja prednost je, da potrebuje malo dodatne opreme (usmernik, merilnik frekvence), pomanjkljivost pa, da zaradi svojih izmer in teže ni primeren za merjenje hitrostnega profila. Elektronski merilnik je primernejši za merjenje hitrosti v večjem številu točk. Njegova prednost so predvsem manjše izmere in teža zaznavalskega dela, kar omogoča premikanje po merilni ravnini pa tudi po kotu. Dodatna prednost elektronskega merilnika je, da lahko analiziramo delovanje turbine in v določeni meri sklepamo tudi o obrabi lopatic in drugih nepravilnostih. Povzamemo torej lahko, da je elektronsko zaznavalo perspektivnejše, verjetno pa se bo zaradi primerjave rezultatov še nekaj časa uporabljalo hkrati z mehanskim merilnikom.

Obstaja kar nekaj možnosti za izboljšave, predvsem pri elektronskem merilniku. Z optimiranjem

to one of eight turbine blades and represents the time delay between the particles' ejection of the observed blade and its forerunner blade. The results are shown in Figure 12. The average delay is 2.53 ms and corresponds well to the excitation frequency of 400 Hz. Curves $\Delta 65$ and $\Delta 76$ deviate the most from the average level. Blade 6 ejects the particles too soon, and the delay between the ejection of blades 5 and 6 is reduced. On the other hand, the delay between the ejection of blades 6 and 7 is increased. The similar, but less distinctive, deviation can be observed for curves $\Delta 21$ and $\Delta 32$, and shows evidence of blade 2 malfunctioning. These findings were confirmed by an inspection of the rotor. It was found that two of the symmetrically mounted blades were worn out much more than the other six blades, which are made from a different, more abrasion-resistant, alloy.

4 CONCLUSIONS

This paper presents two different methods for particle velocity measurement in a shotblasting machine. The mechanical device with two rotating disks is robust and can only be applied for velocity measurements in a few locations within a testing chamber. Its advantage over the electronic system is that almost no extra equipment is necessary except a rotational speed controller and an electronic tachometer. Its main disadvantage is the lack of mobility. It cannot, therefore, be used for the velocity profile measurements of a particle stream. Measurements using the electronic system can be performed in almost any location within a testing chamber. Its sensors are small and light and can be easily positioned in a measuring plane and inclined at a specified angle. Its additional advantage over the mechanical measuring device is that it can be used to analyse the operation of the turbine and make conclusions about turbine-blade wear and other similar malfunctions.

There are still some possible modifications for the electronic system. The construction of the micro-

konstrukcije mikrofonskega zaznavala (debelina jeklene membrane, vpetje membrane, dušenje motenj) lahko povečamo občutljivost elektronskega merilnika in se v idealnem primeru izognemo uporabi filtrov, kar bi zelo poenostavilo algoritem za štetje udarcev in izračun hitrosti, s tem pa tudi povečalo točnost rezultatov.

phone sensor can be optimised (membrane thickness, membrane support, disturbances damping) for higher sensitivity of the sensor. In an ideal case, signal filtering would be unnecessary. This would simplify the algorithm for the signal analysing and particle velocity calculation, and the accuracy of the algorithm would also increase.

5 LITERATURA 5 REFERENCES

- [1] Marinković, J. (1950) Unutrašnja balistika, *Izdavačko poduzeće Narodne republike Srbije*, Beograd.
- [2] Jamakawa, M., S. Isshiki, J. Lee, K. Nishida (2001) 3-D PIV analysis of structural behavior of D.I: gasoline spray, *SAE Paper 2001-01-3669*.
- [3] Merjenje zvoka in oktavna analiza, National Instruments, *NIDAN 1999*, Ljubljana.
- [4] Cooley, J.W., J.W. Tukey (1965) An algorithm for the machine calculation of complex Fourier series, *Mathematics of Computation*, vol. 19, 297-301.
- [5] LabVIEW Measurements manual, *National Instruments*, 2000.

Naslova avtorjev: dr. Aleš Hribernik
mag. Gorazd Bombek
Univerza v Mariboru
Fakulteta za strojništvo
Smetanova 17
2000 Maribor
ales.hribernik@uni-mb.si
gorazd.bombek@uni-mb.si

Ivan Markočič
Gostol-TST
Tolmin

Author's Addresses: Dr. Aleš Hribernik
Mag. Gorazd Bombek
Faculty of Mechanical Eng.
University of Maribor
Smetanova 17
2000 Maribor, Slovenia
ales.hribernik@uni-mb.si
gorazd.bombek@uni-mb.si

Ivan Markočič
Gostol-TST
Tolmin

Prejeto: 20.12.2002
Received:

Sprejeto: 31.1.2003
Accepted: