

Numerical computation of turbulent conjugate heat transfer in air heater

Hriberšek, M.^a, Širok, B.^b, Žunič, Z.^a, Škerget, L.^a

^a Faculty of mechanical engineering, Smetanova 17, SI-2000 Maribor, Slovenia,

^b Turboinstitut, Rovšnikova 7, SI-1000 Ljubljana, Slovenia

Abstract

The contribution deals with numerical simulation of conjugate heat transfer in air heater of the laundry dryer. The heat transfer consists of internal heat generation in the electrical heating coils, forced convection from the coils to the air and heat conduction through the metal walls of the heater. In order to simplify the computational mesh the porous media concept was used for discretization of electrical coils. A special attention was given to the selection of a turbulence model, capable of accurate solution of conjugate heat transfer. After extensive testings the SST model, used in the numerical code CFX5, was selected. The computational results were compared with results of velocity and temperature measurements on the device in the laundry dryer, and good agreement was observed.

Introduction

One of the most important units in a laundry dryer is the air heating system, consisting of a fan and an electrical air heater. The air heater consists of four heating coils, an inner and an outer housing, schematically presented in Fig. 1. Its main task is to heat the recirculated drying air and to uniformly distribute the air to the drying drum. Due to short distances and complex geometry of the heating section the latter task is hard to accomplish. The use of CFD technique can serve as a tool of determination of critical areas in the heater, where nonuniformity of heating and air flow is occurring, and to perform a parametric analysis in order to achieve a desired heat and flow conditions. Nonuniformity of temperature field can have a negative impact of drying material, especially on shrinkage.

The paper gives a deeper insight into numerical modeling of the heat and flow conditions in the air heater of the laundry dryer. In the first part, the main transport phenomena, participating in the heater, are discussed and described by stating the proper physical model. This is followed by description of the geometrical model and boundary conditions, largely determined by the experimental work. A special attention is given to the selection of a turbulence model, capable of accurate solution of conjugate heat transfer. The paper ends with discussion of computational results.

Transport phenomena in air heater

The conjugate heat transfer problem in the air heater can be divided into three main areas:

- non-isothermal flow of air through channels of the heater,

$$\frac{\partial v_j}{\partial x_j} = 0 \quad , \quad (1)$$

$$\frac{Dv_i}{Dt} = \nu_f \frac{\partial^2 v_i}{\partial x_j \partial x_j} - \frac{1}{\rho} \frac{\partial P}{\partial x_i} - \Phi \frac{\nu_f}{K} v_i - \Phi \frac{C_F}{\sqrt{K}} |v_i| v_i, \quad (2)$$

$$\frac{DT}{Dt} = \kappa_f \frac{\partial^2 T}{\partial x_j \partial x_j} + \frac{q_{I,f}}{\rho c} \quad , \quad (3)$$

- transient heat conduction through the plates,

$$\frac{\partial T}{\partial t} = \kappa_s \frac{\partial^2 T}{\partial x_j \partial x_j} \quad . \quad (4)$$

In case of flow through porous region, the parameter $\Phi = 1$, otherwise $\Phi = 0$. The momentum equation for porous part of domain ($\Phi = 1$) contains the Darcy term, the Brinkman term and the Forchheimer term. The equations set (1) - (4) has to be solved numerically by the use of an approximation method.

Nomenclature

C_F	dimensionless form-drag constant	t	time
c_p	specific isobaric heat	T	temperature
$D/D(\dots)$	the substantial derivative	v_i	the i -th velocity component
f	subscript for air	x_i	i -th coordinate
k	turbulent kinetic energy	ϵ	dissipation rate of k
K	permeability of the porous medium	λ	heat conductivity
P	modified pressure ($p - \rho g_j r_j$)	κ	thermal diffusivity
Pr_t	turbulent Pr number	κ_t	turbulent thermal diffusivity
q_I	specific heat source	ν	kinematic viscosity
s	subscript for solid wall	ν_t	turbulent viscosity
		ρ	mass density

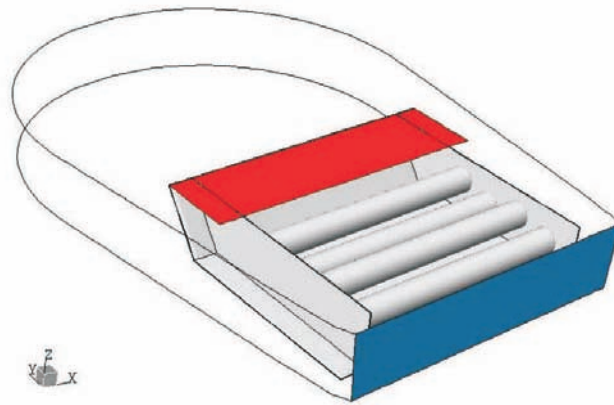

Figure 1: Heater unit with inlet and outlet planes.

Numerical model

Determination of heat and flow conditions in the electrical heater was performed by using CFX-5.6 CFD code. The code is based on the SIMPLEC coupling algorithm with discretisation of the governing equations by the Finite Volume Method (details in [4]).

In order to predict heat and flow conditions in the unit, a conjugate heat transfer model, which includes heat convection between the air and the solid walls and conduction through the walls, had to be implemented. Additionally, the electrical heating coils were modeled as porous medium. This was necessary as the diameter of the wires is two orders of magnitude smaller than dimensions of the heater, what would result in a stretched and dense computational mesh. As the heating coils do not present a significant flow resistance the permeability and porosity of the medium were set reasonably large, and the Forchheimer's resistance coefficient was set as 1, thus representing low resistance to fluid flow in the area of the heating coils.

The air in the unit heats due to heat transfer from hot electrical wires to the fluid. The known electrical power input was used for the computation of the value

of volumetric internal heat generation in the porous medium. In order to make the numerical model feasible, the chosen computational domain was limited to the heater, the surrounding cover and a part of the incoming channel from the fan. The resulting computational model consisted of 205,500 finite volumes.

Due to high values of velocities in the domain natural convection effects were not included in the computation. A decoupled computation of flow field and conjugate heat transfer was therefore performed.

The solution procedure with CFX-5.6 was as follows:

1. Prescribe the known velocity profile at the inlet of the domain and the known inlet air temperature.
2. Start with some initial values in the domain: $v_{i,0} = 0, T_0 = 0$.
3. Compute flow field inside the fluid domains.
4. Compute conjugate heat transfer with known velocity field from step 3.

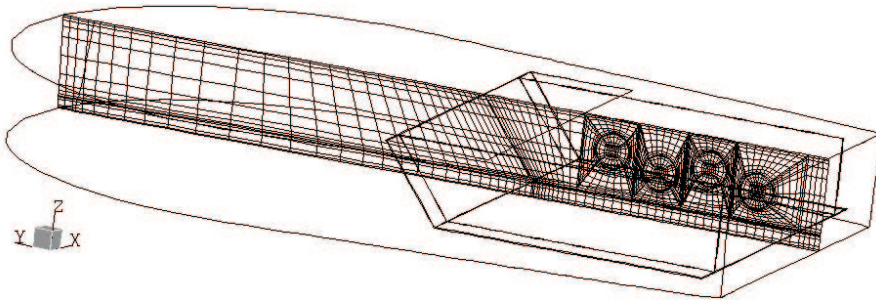

Figure 2: Computational mesh

Turbulence models

Measurements of the inlet velocity field showed that the flow in the heater is in a turbulent regime. This has to be accounted for in the numerical model of the problem. The mostly applied engineering approach is to use the Reynold Averaged Navier-Stokes (RANS) equations for the solution of turbulent flows in complex geometries. In eddy viscosity RANS model, the momentum transfer due to fluctuations in velocities is modeled by the gradient diffusion hypothesis, resulting in a modified values of kinematic viscosities. These are now sums of molecular viscosity and turbulent viscosity,

$$\nu_f = \nu + \nu_t. \quad (5)$$

the latter dependent on flow conditions. A similar approach is used with the energy equation, where the heat diffusivity is a sum of molecular heat diffusivity and turbulent heat diffusivity,

$$\kappa_f = \kappa + \kappa_t \quad (6)$$

In estimating the κ_t the general engineering approach is to set

$$\kappa_t = \frac{\nu_t}{Pr_t} \quad (7)$$

Similarity between the turbulent momentum and turbulent heat transport was assumed and the $Pr_t \approx 0.9$ was set.

In order to solve dynamical equations the turbulent viscosity must be specified. The turbulent viscosity is modeled as the product of a turbulent velocity and turbulent length scale. The standard RANS model is the $k - \epsilon$ model, which solves two additional transport equations, one for turbulent kinetic energy k and one for dissipation rate of turbulent kinetic energy, ϵ . In two-equation models the turbulence velocity scale is computed from the turbulent kinetic energy, and the turbulent length scale is estimated from the turbulent kinetic energy and its dissipation rate.

Different turbulence models are obtained depending on the way in which ν_t is computed. In the $k - \epsilon$ turbulence model the turbulent viscosity is given by relation

$$\nu_t = C_\nu \frac{k^2}{\epsilon}, \quad (8)$$

where ϵ is the rate of turbulent energy dissipation. Both turbulence quantities k and ϵ are determined from the individual transport equations.

While standard two-equation models provide good predictions for many flows of engineering interest, there are applications for which these models fail. Among these some occur also in our case, like flow with boundary layer separation. Additionally, without accounting for the transport of the turbulent shear stress, the standard two equation turbulence models give an overprediction of the eddy-viscosity, which directly affects heat transfer rate in the near wall region. As conjugate heat transfer from the fluid through the inner housing solid wall is influenced by the flow conditions near the solid boundary, accurate prediction of turbulent viscosity and recirculation regions is of main importance in assuring an accurate overall heat transfer.

From equations (3) and (7) it is evident that the most important parameter for an accurate determination of conjugate heat transfer between the fluid and the solid is the value of the turbulent viscosity in the near wall region, i.e. in finite volumes adjacent to the solid wall. From this point of view it is already questionable how a standard wall-function based $k - \epsilon$ model could perform in such a case, resulting in a need for the use of a turbulence model, that accurately resolves transport equations for turbulence quantities up to the wall.

Today, there are already several extensions to general two-equation turbulence models, that account for this phenomena. One of them is the $k - \omega$ based SST model, implemented in CFX 5, which improves flow separation predictions significantly. It accounts for the transport of the turbulent shear stress and gives highly accurate predictions of the onset and the amount of flow separation under adverse pressure gradients. Like any two-equation turbulence model, the $k - \omega$ model solves two additional transport equations, one for the turbulent kinetic energy k , and the other for the turbulent frequency ω .

In the SST model, the proper transport behavior can be obtained by a limiter to the formulation of the eddy-viscosity.. The SST model originates in a combination of the $k - \omega$ model near the wall and the $k - \epsilon$ model away from the wall, i.e. combining the best elements of the $k - \epsilon$ and $k - \omega$ models with the help of special blending functions, [5].

Experimental determination of boundary conditions

The velocity field at the inlet plane was measured by the two-component TSI-LDA system. The measured isolines of velocity components in the z (normal direction regarding the inlet plane) and the x (tangential wide direction regarding the inlet plane) direction clearly indicate that

- a) there is a significant outflow region (Fig.3, upper right corner) at the inlet plane, which is a results of a large recirculation region caused by the nonuniform velocity flow from the fan, placed in front of the heater,
- b) there is a strong tangential flow (Fig.4, left side) in the x direction.

Both phenomena have a strong influence on development of velocity field inside the heater, namely a build up of two recirculation regions along the side walls of the inner housing walls, as can be seen from the computational results, Fig. 9.

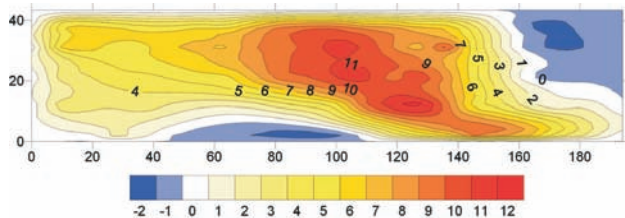

Figure 3: Contours of measured values of v_z velocities at the inlet.

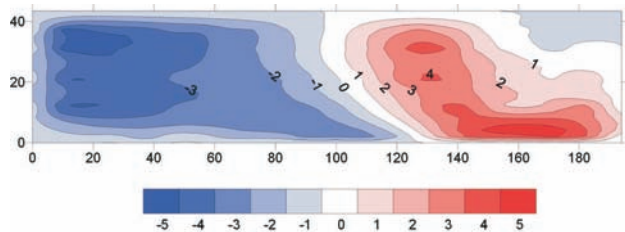

Figure 4: Contours of measured values of v_x velocities at the inlet.

The grid of measured values of velocity components was used for bilinear interpolation of experimental re-

sults to the grid points of the computational mesh, and for the consequent prescription of velocity boundary conditions at the inlet plane. At the outlet of the heater, the open boundary conditions ([4]) were prescribed.

At the outer housing of the heater the free convection heat transfer coefficient was prescribed as $4W/m^2K$. The incoming air temperature was $338K$, and the temperature of the ambient air was set as $293K$.

Computational results

To test the computational model on the selected computational mesh both the $k - \epsilon$ and the SST turbulence model were included in the computation. Severe differences occurred in the computational results for the computation of conjugate heat transfer. The $k - \epsilon$ model overpredicted values of turbulent viscosity in the near wall region, Fig. 5, resulting in the decrease of heat transfer through the solid walls of the heater. The higher values of effective viscosity in the near wall region slows down the flow and consequently the heat transfer rate, resulting in lower temperatures at the wall and low heat fluxes through the solid walls. The SST turbulence model gave much more realistic predictions of turbulent viscosity, leading to higher temperatures of the walls and higher heat fluxes through the walls, [5]. In the core of the fluid, both models gave similar results, which is due to the nature of the SST model, as it uses the $k - \epsilon$ model for this flow region. These comparisons clearly indicate that the $k - \epsilon$ model in its used form (wall functions) is not appropriate for the conjugate heat transfer computations, and therefore the SST model was used in all further computations.

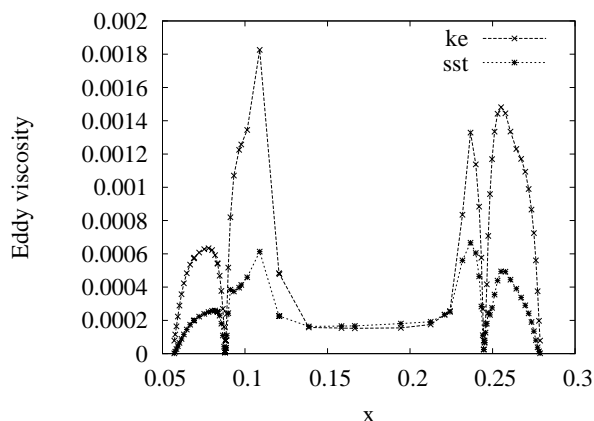

Figure 5: Contours of turbulent viscosities in the cross section through the heater, ke - $k - \epsilon$ model, sst - SST model.

The flow field inside the heater unit is characterized by two large recirculation regions, Fig. 9, one

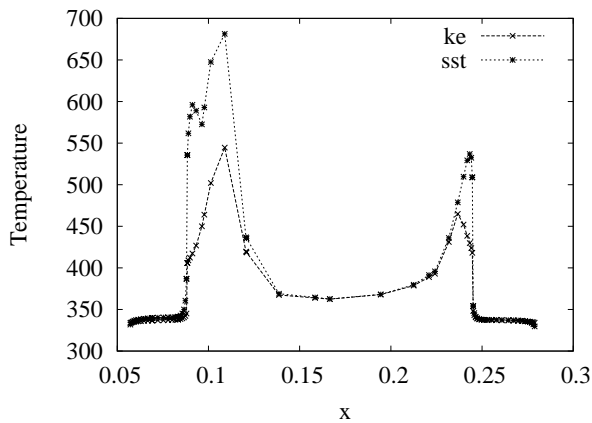

Figure 6: Contours of temperatures in the cross section through the heater, ke - $k - \epsilon$ model, sst - SST model.

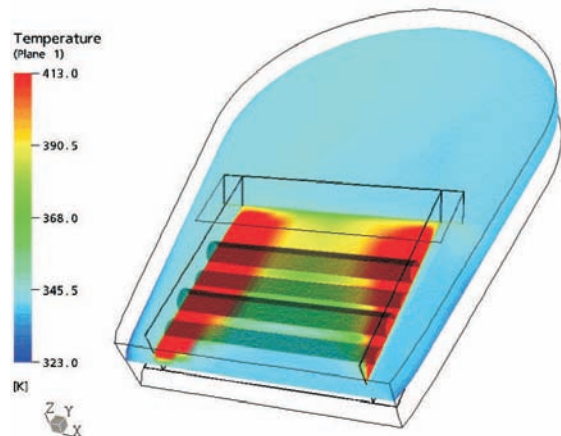

Figure 8: Contours of temperatures for the SST model.

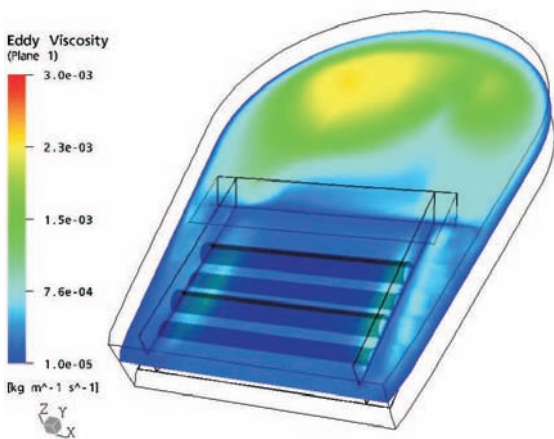

Figure 7: Contours of turbulent viscosity for the SST model.

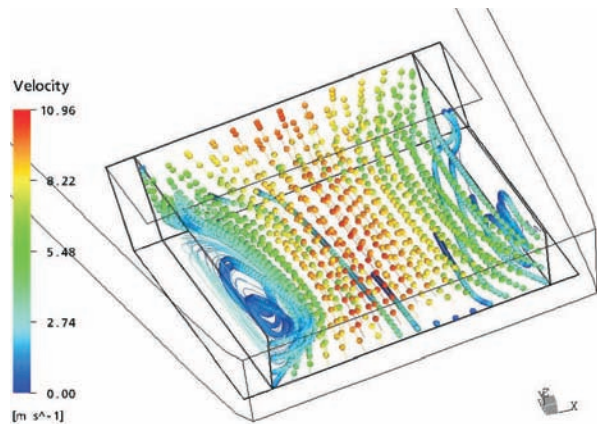

Figure 9: Streaklines in the inner part of the heater.

at the left and one at the right inner solid walls, a result of nonuniform inlet conditions. These regions are responsible for increased temperatures at the outlet of the heater.

In Figure 10 the recorded temperature field at the inlet to the drying drum is presented. As experimental tool the thermovision device AGEMA 570 of FSI Flir Systems was used. When comparing these results with the results of computations the fact that experiment was conducted with no recirculation loop for the heated air should be taken into consideration, i.e. the overall temperature level is lower than computed with numerical model, which considers real conditions inside the operating drying machine. An interesting comparison between the experimental and computational results can be drawn from Figures 11 and 12. The numerical results are in good agreement with experimental temperature field, especially regarding the positions of the high temperature regions, that should be avoided in ideal operating conditions. Also, the quantitative

comparison of the temperature levels shows good agreement in the range of $+10K$, considering the temperature difference of $40K$ between the inlet air temperature in experiment and prescribed working temperature in the numerical model.

The existence of recirculation regions at the left and right walls has its impact on temperatures of the coils. In the region, where flow was recirculating, the temperature was much higher than in the region of the main flow, a result of low exchange of heated air from this region to the main flow. This effect can cause undesired increase of temperature of the wires and can cause the connected temperature sensor to disconnect the corresponding coil for a certain period of time. The heat input to the air could be therefore lower than normal, impacting the drying conditions inside the drum.

Conclusions

The contribution presented a development of a feasible numerical model for accurate computation of conjugate heat transfer inside the heater unit of the laun-

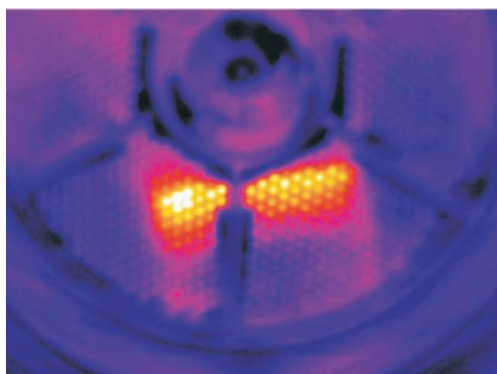

Figure 10: Thermovision recorded temperature field at the outlet.

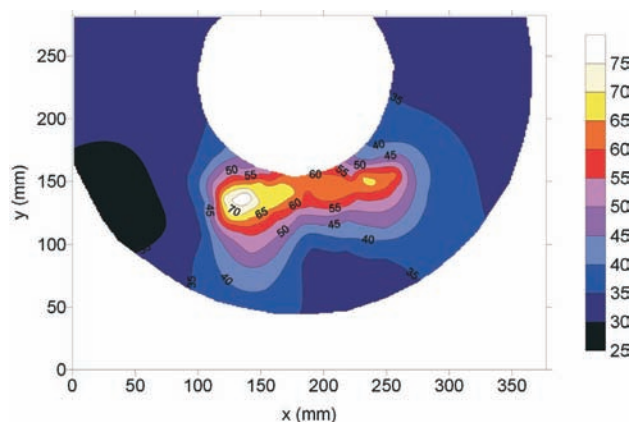

Figure 11: Isotherms of the recorded temperature field at the outlet.

dry dryer. The study of influence of turbulence model on accuracy of computational results for the case of conjugate heat transfer was performed, with comparison of the standar wall function based $k - \epsilon$ model and the SST model. The comparison between the models as well as with the measured temperature field showed that the use of the standard $k - \epsilon$ model results in physically unrealistic heat conditions in the near wall region, whereas the SST model gave accurate computational results. The comparison of results, obtained by using the SST model, with experimental results using Thermovision The developed numerical model can now be used as a main part of parametric study of the air heater performance.

References

[1] Conde, M. R. (1997) Energy conservation with tumbler drying in laundries. *Applied Thermal Engineering*, Vol. 17, No. 12, pp. 1163-1172.

[2] Deans, J. (2001) The modelling of a domestic tum-

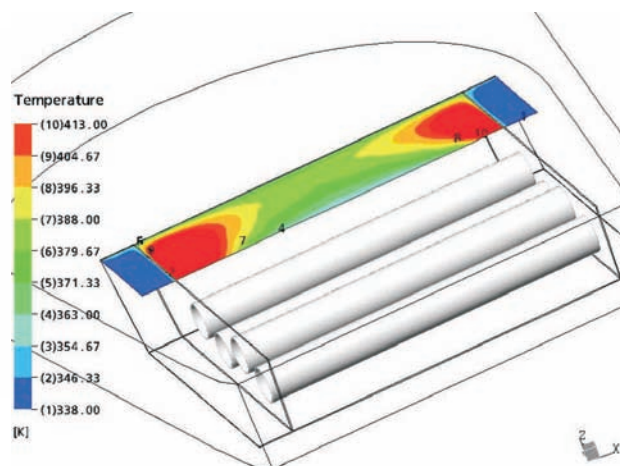

Figure 12: Temperature field at the outlet.

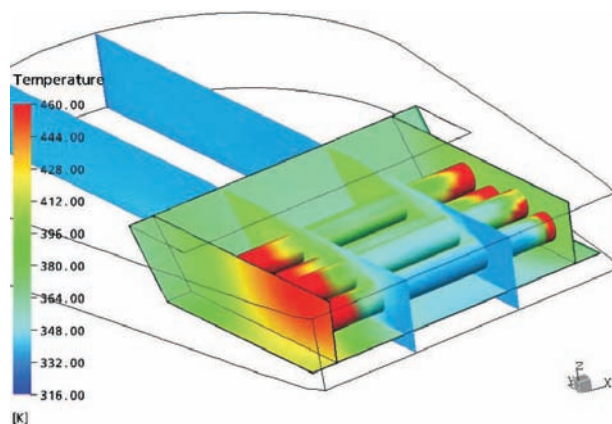

Figure 13: Temperature field in the vicinity of heating coils.

bler dryer. *Applied Thermal Engineering*, Vol. 21, pp. 977-990.

[3] Hriberšek, M., Bašič, S., Škerget, L., Širok, B. (2001) Numerical modeling of heat and fluid flow conditions of a laundry dryer condenser. PIERUCCI, S. (ed.), *The Fifth Italian Conference on Chemical and Process Engineering, ICheaP-5*, Florence, Italy, May 20-23, 2001. Proceedings. Milano: AIDIC, 2001, vol. 2, pp. 759-764.

[4] CFX5.6 (2003). User's manual, AEA Technology.

[5] Vieser, W., Esch, T., Menter, F.: Heat transfer predictions using advanced two-equation turbulence models. CFX Validation report, CFX-VAL10/1002.