

# *Current-mode Quadrature Oscillator using CCCCTAs with Non-interactive Current Control for CO, FO and Amplitude*

*Adirek Jantakun*

*Department of Electronics and Telecommunication Engineering, Faculty of Engineering, Rajamangala University of Technology Isan, Khonkaen Campus, Khonkaen, Thailand*

**Abstract:** This paper presents a current-mode quadrature oscillator with amplitude controllability. The proposed circuit consists of two current controlled current conveyor transconductance amplifiers, two grounded capacitors and one grounded resistor. The condition of oscillation, frequency of oscillation and amplitude of output current can be independently controlled with electronics method via DC bias current. In addition, the proposed oscillator has high impedance of outputs ports which facilitates easy driving an external load without additional current buffers. It also uses all grounded passive elements which suitable for implementation in the integrated circuit. The theoretical results are verified by PSPICE simulation and experimental results that well conform to the theoretical anticipation.

**Keywords:** Current-mode; Quadrature Oscillator; Current Controlled Current Conveyor Transconductance Amplifier; Grounded Elements

## *Kvadraturni oscilator v tokovnem načinu z uporabo CCCCTA z neinteraktivno kontrolo toka za CO, FO in amplitudo*

**Izvleček:** Članek opisuje tokovno krmiljen kvadraturni oscilator z nadzorom amplitude. Predlagano vezje je sestavljeno iz dveh tokovno krmiljenih transkontuktančnih ojačevalnikov, dveh ozemljenih kondenzatorjev in ozemljenega upora. Frekvenca in amplituda oscilatorja je neodvisno nastavljiva preko vhodnega DC toka. Predlagan oscilator ima visoko izhodno impedanco, ki omogoča enostavno krmiljenje zunanjih bremen brez dodatnih virov. Zaradi ozemljenih pasivnih elementov je primerno za integrirana vezja. Teoretični izračuni so preverjeni v PSPICE in eksperimentalno potrjeni.

**Ključne besede:** tokovni način; kvadraturni oscilator; tokovno krmiljen transkonduktančni ojačevalnik; ozemljeni elementi

\*Corresponding Author's e-mail: [mr.adirek@hotmail.com](mailto:mr.adirek@hotmail.com)

### *1 Introduction*

An oscillator which provides two sinusoidal signals with 90° phase difference, or well known as quadrature oscillator, has been continuously proposed since it plays an important role and has been widely applied in various applications such as communication, instrumentation, measurement and signal processing, etc [1-4]. Especially in communication systems, the sinusoidal oscillator is frequently used to generate the carrier signal for modulation system [5-6] such as AM, FM, ASK etc. Normally, the oscillator would generate the signal without amplitude controllability. So in some applica-

tions which need the exact amplitude, the amplifier circuit is required, causing the complicated circuit. Recently, the portable electronics devices which run on compact batteries have been necessary to reduce voltage power supply and power consumption. These requirements call for the development of current-mode circuit designs due to their potential advantages such as inherently wide bandwidth, higher slew-rate, greater linearity, wider dynamic range, simple circuitry and low power consumption [7-8].

Several quadrature oscillators have been proposed in the literature [9-29]. A lot of them focus on the use of electronically adjustable active building blocks (ABB), such as, current controlled current conveyor (CCCII), current conveyor transconductance amplifier (CCTA), current controlled current conveyor transconductance amplifier (CCCCTA), differential voltage current conveyor transconductance amplifier (DVCCTA), current follower transconductance amplifier (CFTA) and current controlled current follower transconductance amplifier (CCCFTA). Some parameters (such as transconductance or parasitic resistance) of these ABBs are tuned by external current or voltage which is easy to control by microcontroller or microcomputer. The review of these oscillator topologies is as follows. The oscillators in Ref. [9-29] use grounded capacitor which is attractive for integrated circuit implementation. In Ref. [9-10], the electronic tuning of frequency of oscillation (FO) by adjusted parasitic resistance  $R_x$  is achieved. However, the condition of oscillation (CO) is controlled by current gain control, which is not so common [30-31]. CC-CIIs based sinusoidal oscillator was introduced in [11].

The magnitude of sinusoidal output current can be electronically adjusted as well as the frequency of oscillation, but this oscillator circuit employs three CCCIs and the control of CO is done by adjusting the value of capacitor which is unconventional. The proposed oscillators in [12-14] exhibit advantages in electronic tuning of the FO by the transconductance  $g_m$ , but the CO is controlled by change the value of passive resistor, which cause addition complication [30-31]. Although electronic adjusting can be used by digital potentiometer, but it is difficult for implementation [31]. The FO in [12, 19-24] is electronically adjusted by the transconductance gain  $g_m$ . Some oscillators in [17, 25], the FO and CO cannot independently controlled. The circuits in [18-23, 26-27] can be electronically adjusted the CO and FO. The magnitude of sinusoidal output signal in [28] can be electronically adjusted but the FO and CO cannot be electronically adjusted. However, the amplitude of output signal in [9-10, 12-27, 29] cannot be electronically controlled. The comparison of proposed oscillator with previous work is shown in Table 1.

**Table 1:** The comparison of proposed oscillator with previous oscillators

Ref.	ABB	No. of ABB	No. of R+C	Electronic tune for both CO and FO	Independent tune of CO and FO	Output current with high impedance	Amplitude controllability
[9]	CG-CCCII	2	0+2	✓	✓	✓	x
[10]	CG-CCCII	2	0+2	✓	✓	x	x
[11]	CCCII	3	0+2	✓	x	✓	✓
[12]	CCTA	1	1+2	x	✓	x	x
[13]	CCTA	1	2+2	x	✓	✓	x
[14]	DVCCTA	1	2+2	x	✓	x	x
[15]	CCCCTA	1	0+2	x	✓	x	x
[16]	MO-CCCCTA	1	0+2	✓	x	✓	x
[17]	CG-CCTA	1	2+2	✓	x	x	x
[18]	CCTA	2	1+2	✓	x	✓	x
[19]	CCCCTA	2	0+2	✓	x	✓	x
[20]	CCCCTA	4	0+2	✓	✓	✓	x
[21]	MCDTA+CFTA	2	0+2	✓	x	✓	x
[22]	CFTA	1	1+2	✓	x	✓	x
[23]	CCCFTA	2	0+2	✓	x	✓	x
[24]	ZC-CFTA	4	0+2	✓	✓	✓	x
[25]	CG-CFTA	2	0+2	✓	x	✓	x
[26]	CCCCT+OTA	2	0+3	✓	x	✓	x
[27]	DO-CCCCTA	1	0+2	✓	x	✓	x
[28]	CDBA	2	3+2	x	x	✓	✓
[29]	DO-CCCCTA	1	2+2	✓	✓	✓	x
proposed circuit	CCCCTA	2	1+2	✓	✓	✓	✓

The purpose of this paper is to present the quadrature oscillator using CCCCTAs. The proposed circuit provides the following advantage features:

The current-output signal from high-impedance is easy to drive a load without using a buffering device [30-32]. The proposed circuit uses only grounded capacitors which are advantageous from the point of view of integrated circuit implementation [30-32].

The CO and FO can be electronically and independently controlled.

The amplitude of output current can be controlled via external bias current without effect of the CO and FO, which can provide the AM and ASK signal, widely used in communication systems [32].

Low active and passive sensitivities.

The workability of the proposed sinusoidal oscillator is confirmed via the PSPICE simulation and experiment.

## 2 Current Controlled Current Conveyor Transconductance Amplifier (CCCCTA)

Since the proposed circuit is based on CCCCTA [15], a brief review of CCCCTA is given in this section. It was modified from the first generation CCTA [8]. The characteristics of the ideal CCCCTA are represented by the following hybrid matrix:

$$\begin{bmatrix} I_y \\ V_x \\ I_{z,zc} \\ I_o \end{bmatrix} = \begin{bmatrix} 0 & 0 & 0 & 0 \\ 1 & R_x & 0 & 0 \\ 0 & 1 & 0 & 0 \\ 0 & 0 & 0 & \pm g_m \end{bmatrix} \begin{bmatrix} V_y \\ I_x \\ V_o \\ V_z \end{bmatrix} \quad (1)$$

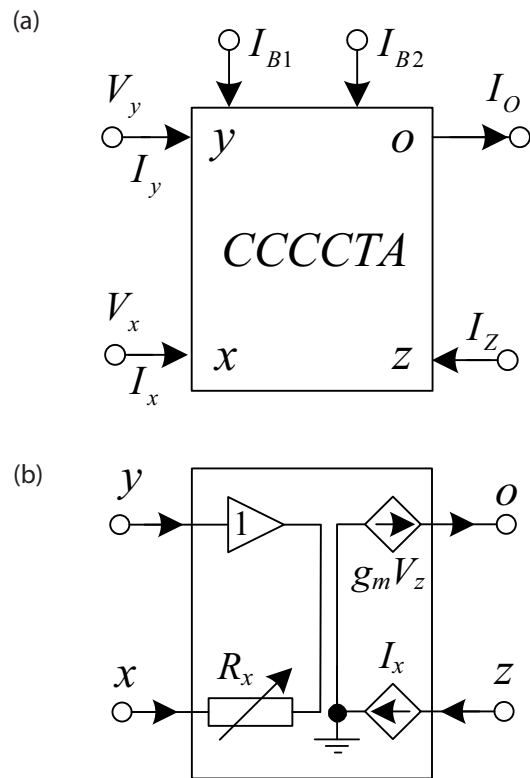
For the CCCCTA implemented by a bipolar technology, the parasitic resistance  $R_x$  is given as

$$R_x = \frac{V_T}{2I_{B1}} \quad (2)$$

and transconductance  $g_m$  is given as

$$g_m = \frac{I_{B2}}{2V_T} \quad (3)$$

The circuit symbol and equivalent circuit of the CCCCTA are illustrated in Fig. 1(a) and (b), respectively



**Figure 1:** CCCCTA (a) schematic symbol (b) equivalent circuit

## 3 Proposed circuit configuration

The proposed quadrature oscillator is shown in Fig. 2. It consists of two CCCCTAs, two grounded capacitors and one grounded resistor. The quadrature output current ports are  $I_{o1}$ ,  $I_{o2}$  and  $I_{o3}$  is the output current with amplitude controllability. The use of grounded passive element is advantageous from the point of view of integrated circuit implementation [30-32]. Moreover, it is found that the oscillator provides high output impedance which can directly drive a load without buffering devices [30-32]. Using (1) and doing routine circuit analysis, the system characteristic equation can be expressed as

$$s^2 + \left( \frac{1}{R_1} - \frac{1}{R_{x2}} \right) \frac{s}{C_1} + \frac{g_{m1}}{C_1 C_2 R_{x1}} = 0 \quad (4)$$

From (4), it can be seen that the proposed circuit can produce oscillations if the condition of oscillation is fulfilled

$$R_1 = R_{x2} \quad (5)$$

If the above condition of oscillation is satisfied, the circuit produces oscillation with frequency of

$$\omega_{osc} = \sqrt{\frac{g_{m1}}{C_1 C_2 R_{x1}}} \tag{6}$$

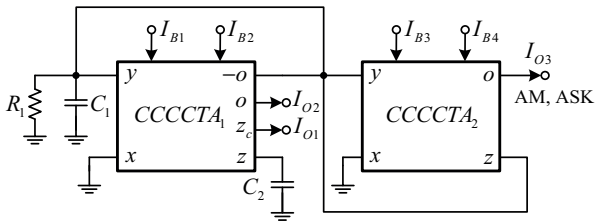
Substituting the parasitic resistance  $R_x$  and transconductance  $g_m$  as respectively shown in (2) and (3) into (5) and (6), the CO becomes

$$I_{B3} = \frac{V_T}{2R_1} \tag{7}$$

and the FO is obtained as

$$f_{osc} = \frac{1}{2\pi V_T} \sqrt{\frac{I_{B1} I_{B2}}{C_1 C_2}} \tag{8}$$

It is found that the CO can be electronically controlled through DC bias current  $I_{B3}$  without effect of the FO. Also, the FO can be electronically tuned through  $I_{B1}$  or  $I_{B2}$  without effect of the CO. Consequently, this circuit enables non-interactive current control for both the CO and the FO.



**Figure 2:** The proposed quadrature oscillator using CCCCTAs

The ratio between output current  $I_{O2}$  and  $I_{O1}$  is

$$\frac{I_{O2}}{I_{O1}} = \frac{g_{m1}}{C_2 s} \tag{9}$$

It is found that the phase difference of output current  $I_{O1}$  and  $I_{O2}$  is  $90^\circ$ . However at oscillation state ( $\omega = \omega_{osc}$ ), the relationship of  $I_{O2}$  and  $I_{O1}$  in (9) is changed to

$$\frac{I_{O2}}{I_{O1}} \Big|_{\omega = \omega_{osc}} = \sqrt{\frac{C_1 g_{m1} R_{x1}}{C_2}} \tag{10}$$

Substituting the parasitic resistance  $R_x$  and transconductance  $g_m$  as respectively shown in (2) and (3) into (10), the ratio between output current  $I_{O2}$  and  $I_{O1}$  becomes

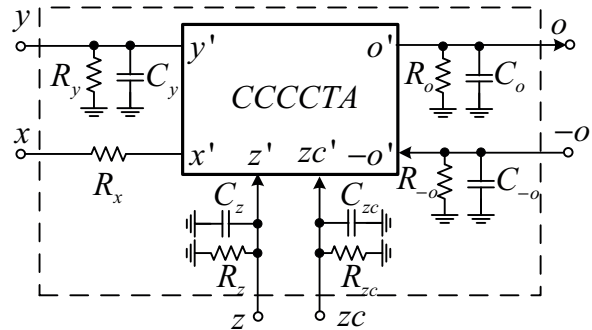
$$\frac{I_{O2}}{I_{O1}} \Big|_{\omega = \omega_{osc}} = \sqrt{\frac{C_1 I_{B2}}{4C_2 I_{B1}}} \tag{11}$$

It is obvious seen from (11) that the tune of  $I_{B2}$  or  $I_{B1}$  for controlling the frequency of oscillation causes change of amplitude  $I_{O2}$  and  $I_{O1}$  during tuning process. When amplitude of  $I_{O2}$  or  $I_{O1}$  increases the voltage at nodes  $V_{y1}$  and  $V_{z1}$  also increase too. This phenomenon will increase the THD if amplitude reaches high levels due to the limits of dynamical range of CCCCTA. However, this can be alleviated by simultaneously changing  $I_{B2}$  and  $I_{B1}$  ( $I_{B2} = I_{B1}$ ).

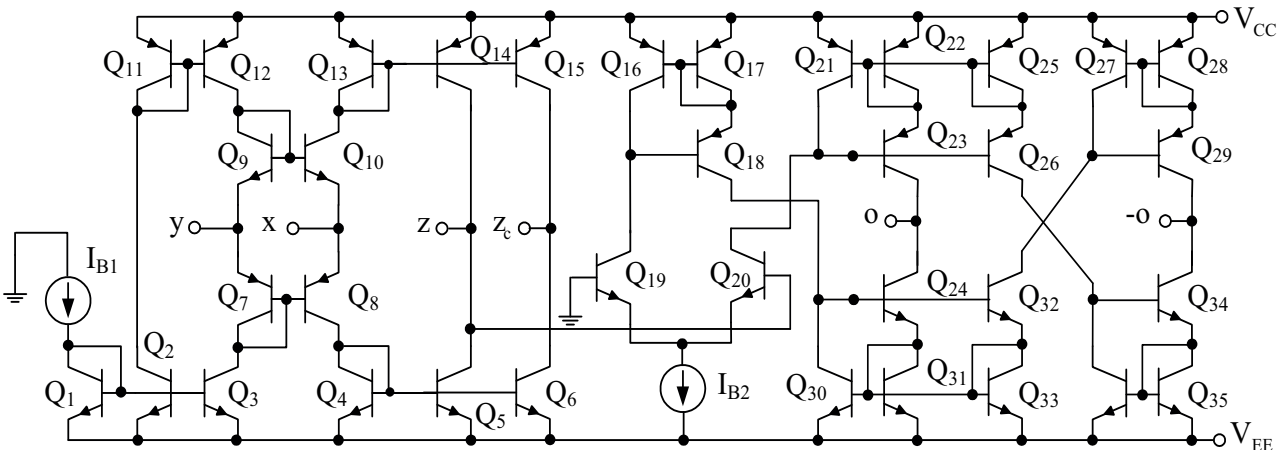
Furthermore, the output current  $I_{O3}$  can be obtained as

$$I_{O3} = g_{m2} V_{z2} \tag{12}$$

From (12), the voltage  $V_{z2}$  is the sinusoidal signal. It means that the amplitude of sinusoidal signal  $I_{O3}$  can



**Figure 3:** The non-ideal CCCCTA



**Figure 4:** The internal construction of CCCCTA

be electronically controlled by  $I_{B4}$  without effect of CO and FO. Therefore, if  $I_{B4}$  is a modulating signal, AM and ASK signal can be obtained at  $I_{O3}$ . In addition, the output current  $I_{O3}$  port is high-impedance. It is easy to drive a load without using a buffering device.

The sensitivities of active and passive for frequency of oscillation are low as shown in (13)

$$S_{g_{m1}}^{\omega_{osc}} = \frac{1}{2}, S_{C_1, C_2, R_{x1}}^{\omega_{osc}} = -\frac{1}{2} \quad (13)$$

#### 4 Non-ideal Analysis

Considering to voltage and current tracking errors, the CCCCTA properties can be written as

$$\begin{bmatrix} I_y \\ V_x \\ I_z \\ I_o \end{bmatrix} = \begin{bmatrix} 0 & 0 & 0 & 0 \\ \gamma & R_x & 0 & 0 \\ 0 & \alpha & 0 & 0 \\ 0 & 0 & 0 & \pm\beta g_m \end{bmatrix} \begin{bmatrix} V_y \\ I_x \\ V_o \\ V_z \end{bmatrix} \quad (14)$$

Where  $\gamma = \gamma_o / (1 + s / \omega_\gamma)$ ,  $\alpha = \alpha_o / (1 + s / \omega_\alpha)$  and  $\beta = \beta_o / (1 + s / \omega_\beta)$ . They are frequency-dependence of non-ideal of voltage and current gains, respectively.  $\omega_\gamma$ ,  $\omega_\alpha$  and  $\omega_\beta$  are dc non-ideal bandwidths with ideality equal to infinity.  $\gamma_o$ ,  $\alpha_o$  and  $\beta_o$  are dc non-ideal gains with ideality equal to unity. Moreover, the effect of parasitic resistances and capacitances are also taken into account. The  $C_y$ ,  $C_z$  and  $C_o$  are parasitic capacitors at y, z and o terminals, respectively, with ideality equal to zero. The parasitic resistors  $R_y$ ,  $R_z$ ,  $R_o$  at y, z and o terminals with ideality equal to infinity. These parasitic components of the CCCCTA are shown in Fig. 3.

Re-analysis the circuit in Fig. 2, the characteristic equation is modified to

$$s^2 + s \left( \frac{G_{z1}}{C_2} + \frac{G_1^*}{C_1} - \frac{G_{x2}}{C_1} \right) + \frac{\beta_1 \gamma_1 \alpha_1 G_{x1} g_{m1} + G_1^* G_{z1} - G_{x2} G_{z1}}{C_1^* C_2^*} = 0 \quad (15)$$

Then, the CO and FO of the proposed circuit become

$$\frac{G_{z1}}{C_2} + \frac{G_1^*}{C_1} - \frac{G_{x2}}{C_1} = 0 \quad (16)$$

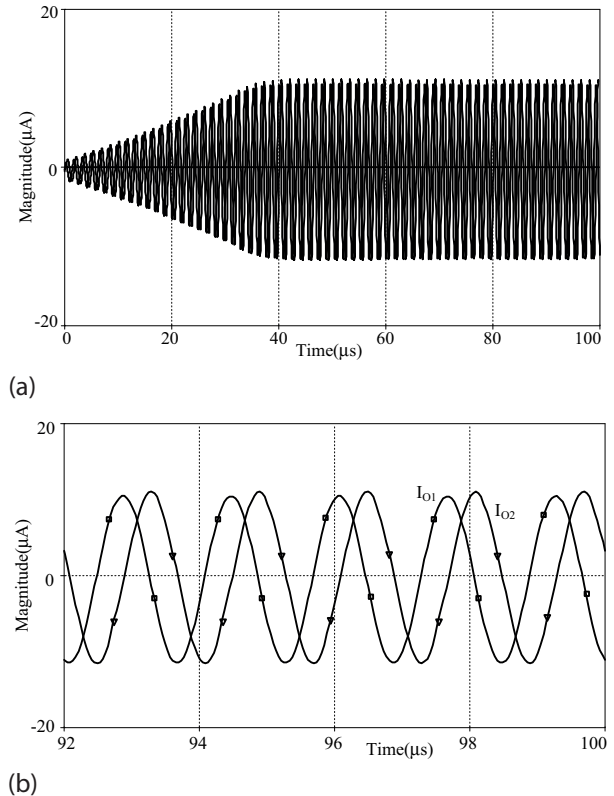
And

$$\omega_{osc} = \sqrt{\frac{\beta_1 \gamma_1 \alpha_1 G_{x1} g_{m1} + G_1^* G_{z1} - G_{x2} G_{z1}}{C_1^* C_2^*}} \quad (17)$$

Where  $C_1^* = C_1 + C_{y1} + C_{y2} + C_{-o1} + C_{z2}$ ,  $C_2^* = C_2 + C_{z1}$   
 $G_1^* = G_{y1} + G_{y2} + G_{-o1} + G_{z2} + G_{R1}$ ,  $G_1 = \frac{1}{R_1}$ ,  $G_{x1} = \frac{1}{R_{x1}}$   
 $G_{x2} = \frac{1}{R_{x2}}$ ,  $G_{y1} = \frac{1}{R_{y1}}$ ,  $G_{y2} = \frac{1}{R_{y2}}$ ,  $G_{-o1} = \frac{1}{R_{-o1}}$ ,  
 $G_{z1} = \frac{1}{R_{z1}}$  and  $G_{z2} = \frac{1}{R_{z2}}$ .

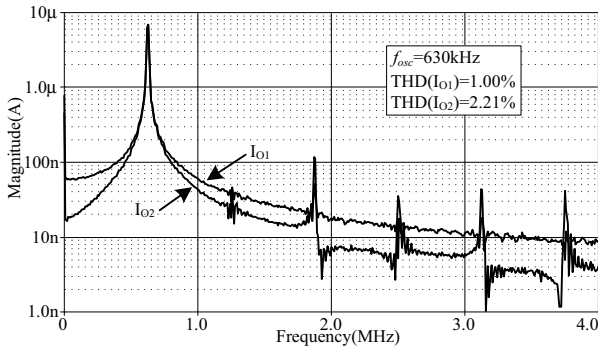
#### 5 Simulation Results

To prove the performances of the proposed oscillator, the PSPICE simulation was performed for examination. The BJT technology was simulated by using the parameters of the PR200N and NR200N bipolar transistors of ALA400 transistor array from AT&T. Fig. 4 depicts the schematic description of the CCCCTA used in the simulations with  $\pm 1.8$  V power supplies.

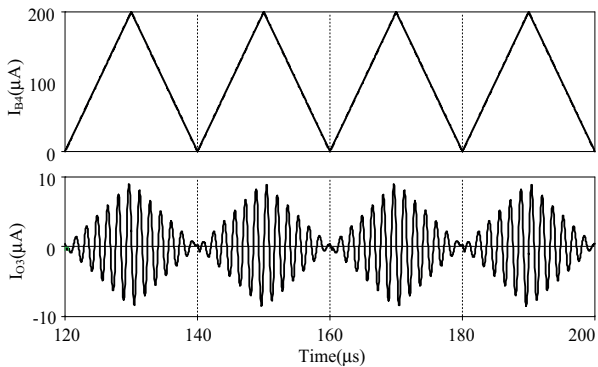


**Figure 5:** The waveforms of sinusoidal oscillator (a) transient state (b) steady state

The sinusoidal oscillator was designed with  $C_1 = 1$  nF,  $C_2 = 0.47$  nF,  $R_1 = 1$  k  $\Omega$ ,  $I_{B1} = 58$   $\mu$ A,  $I_{B2} = 115$   $\mu$ A and  $I_{B4} = 10$   $\mu$ A. From (7), the bias current  $I_{B3}$  was set nearby  $V_T / 2R_1$  to start-up the oscillation, which is  $I_{B3} = 10$   $\mu$ A. The power dissipation of this case is about 4.26 mW. This yields oscillation frequency of 630 kHz. Fig. 5 (a)



**Figure 6:** The frequency spectrum of signal in Fig. 5.



**Figure 7:** The results of operation of AM

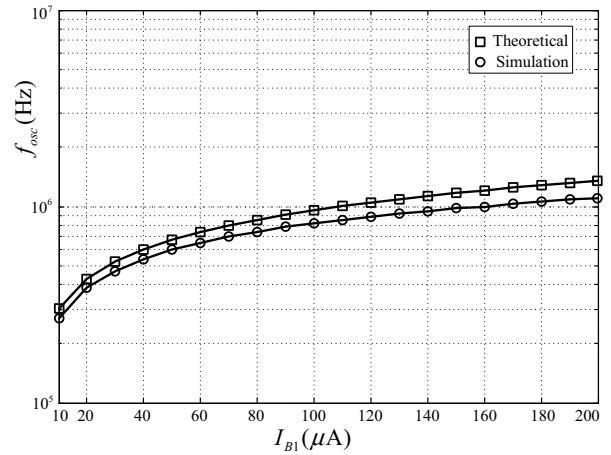
and (b) show simulated output waveforms in transient and steady state, respectively. Fig. 6 shows simulated output spectrum, where the total harmonic distortions (THD) of output current  $I_{O1}$  and  $I_{O2}$  are about 1.00 % and 2.21 %, respectively.

The simulated result of the proposed circuit serving as an AM generator at  $I_{O3}$  is shown in Fig. 7, where  $I_{B4}$  was triangular signal with a 50 kHz frequency. It is confirmed that the proposed circuit can easily generate AM signal.

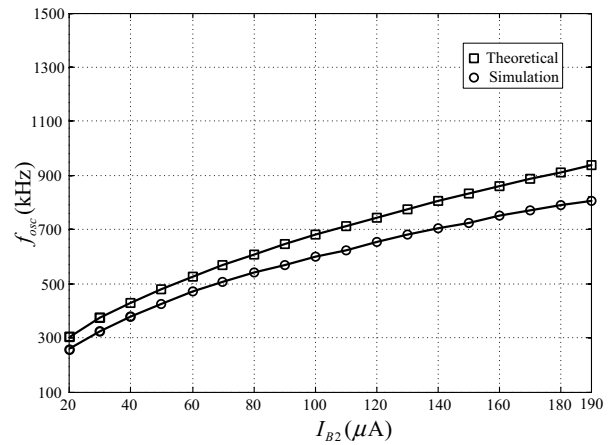
The electronically adjustment of the FO can be demonstrated in Fig. 8 (a), while keeping  $I_{B2} = 115 \mu A$  and tuning bias current  $I_{B1}$  from 10  $\mu A$ -200  $\mu A$ . Similarity, Fig. 8 (b) shows the simulation of FO, which remains  $I_{B1} = 58 \mu A$  and adjusts  $I_{B2}$  from 20  $\mu A$ -190  $\mu A$ . It is clear seen that the simulation results are in accordance with the theoretical analysis as shown in equation (8). The error of the oscillation frequency stems from the non-ideal parameters as depicted in the Section IV. The amplitude of output current  $I_{O1}$  can be exhibited in Fig. 9, when tuning bias current  $I_{B1}$  and  $I_{B2}$ .

## 6 Experimental Results

To prove the theoretical analysis of proposed oscillator, the experimental results are shown in this section. The



(a)



(b)

**Figure 8:** The frequency of oscillation against bias current (a)  $I_{B1}$  (b)  $I_{B2}$

circuit for experiment is illustrated in Fig. 10. It was constructed by using commercial ICs, which are AD844A [33] and LM13700N [34]. The values of components in experimental circuit were chosen as  $C_1 = 1 \text{ nF}$ ,  $C_2 = 0.47 \text{ nF}$ ,  $R_1 = 1.1 \text{ k}\Omega$ ,  $R_{L3} = 1 \text{ k}\Omega$  ( $R_{L3}$  was used to measure the output current by an oscilloscope). The intrinsic resistances  $R_{x1}$  and  $R_{x2}$  are realized by OTA-based grounded resistance simulator with following value

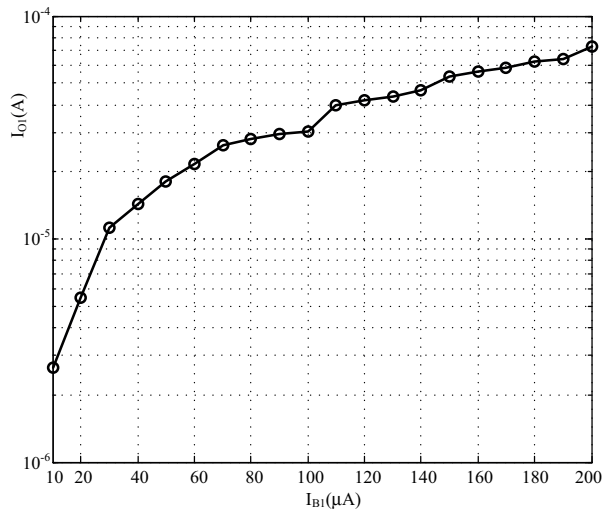
$$R_x = \frac{2V_T}{I_B} \tag{16}$$

From (16) the CO and FO can be rewritten as

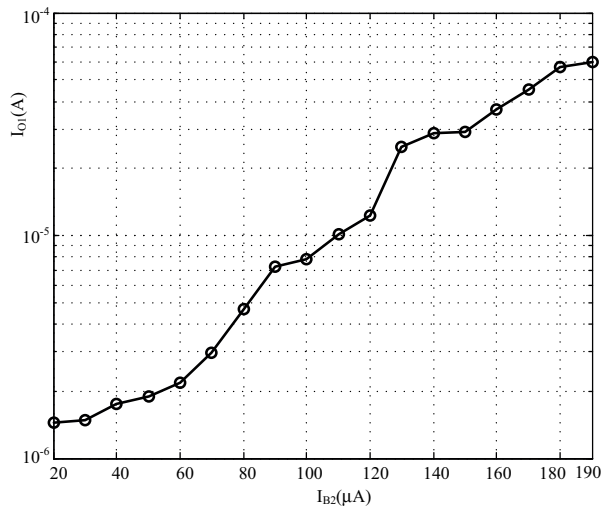
$$I_{B3} = \frac{2V_T}{R_1} \tag{17}$$

And

$$f_{osc} = \frac{1}{4\pi V_T} \sqrt{\frac{I_{B1} I_{B2}}{C_1 C_2}} \tag{18}$$



(a)



(b)

**Figure 9:** The amplitude of  $I_{o1}$  against bias current (a)  $I_{B1}$  (b)  $I_{B2}$

The relationship of  $V_{o2}$  and  $V_{o1}$  is as follows:

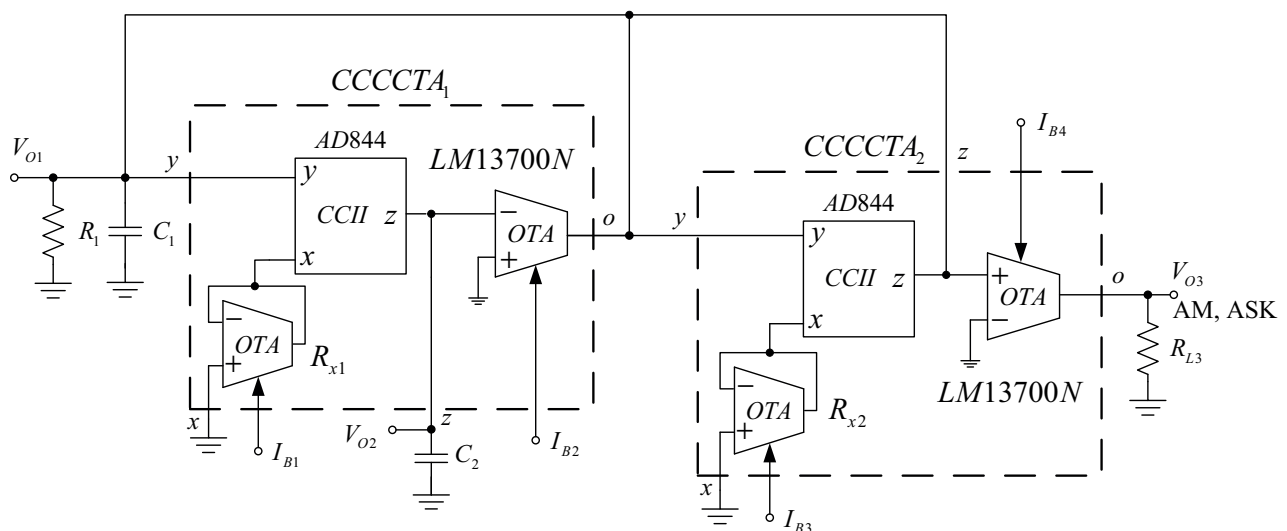
$$V_{o2} = \frac{I_{B1} V_{o1}}{2V_T s C_2} \tag{19}$$

Similarly, the amplitude of output voltage  $V_{o3}$  is shown in (20)

$$V_{o3} = \frac{I_{B4} R_{L3} V_{o1}}{2V_T} \tag{20}$$

The circuit in Fig. 10 was biased with  $I_{B1} = 60 \mu A$ ,  $I_{B2} = 115 \mu A$ ,  $I_{B3} = 56 \mu A$ ,  $I_{B4} = 60 \mu A$  and  $\pm 5 V$  power supplies. An oscilloscope Rigol model DS1046B [35] was used to measure the output waveforms. The waveform of output signals are shown in Fig. 11 (a) where the FO is about 321 kHz. The calculated value of FO from (18) is about 370.84 kHz. The deviation of FO is suffered from parasitic elements of the CCII, OTA and parasitic element of oscilloscope. Moreover, the parasitic influences of the CCII and OTA are shown in Table 2 and 3, respectively. Fig. 11 (b) exhibits the signals of  $V_{o1}$  and  $V_{o2}$ , which are the phase difference of  $90^\circ$  Furthermore, the frequency spectrum of output signals by use signal analyzer Agilent Technologies model N9000A [36] shown in Fig. 12, that is the FO is about 320.6 kHz. The parameters in Fig. 12 can be calculated the THD of  $V_{o1}$ ,  $V_{o2}$  and  $V_{o3}$  are about 1.73 %, 1.53 % and 1.31 %, respectively. These THD ( $V_{o1}$ ,  $V_{o2}$  and  $V_{o3}$ ) are close to the simulation, which are about 1.50 %, 1.27 % and 2.17 %, respectively.

To generate the AM signal,  $I_{B4}$  is feed as triangular waveform with 25 kHz of frequency. The voltage of current converter in Fig. 13 is used for this case. Fig. 14 shows the AM signal. It is clearly seen that this result confirms the theoretical analysis as shown in (20).



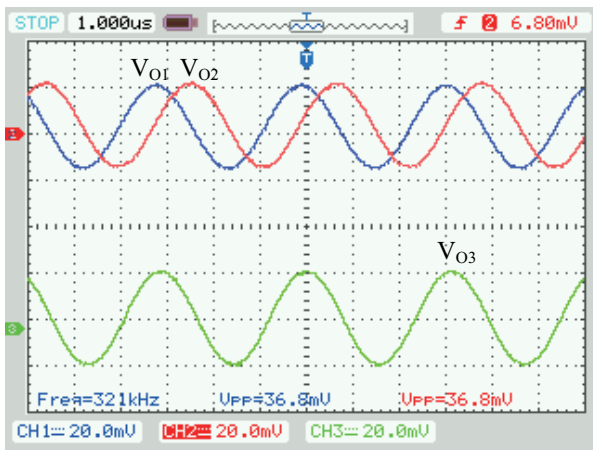
**Figure 10:** The oscillator circuit for experimental test

**Table 2:** The parasitic influences of CCII (AD844A) [33]

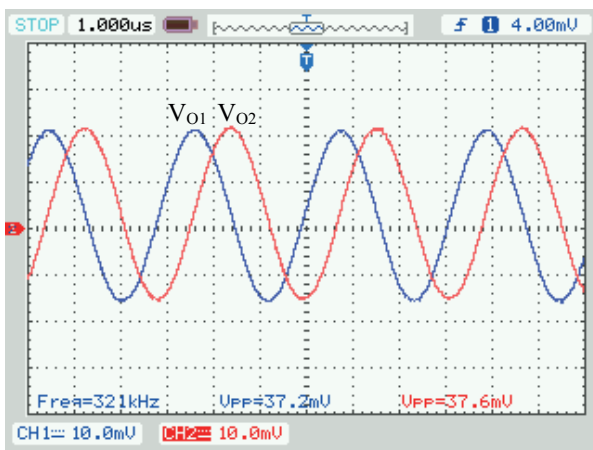
Port	Resistance	Capacitance
y	7 MΩ	2 pF
x	6.5 Ω	2 pF
z	3 MΩ	4.5 pF

**Table 3:** The parasitic influences of OTA (LM13700N) [34]

Port	Resistance	Capacitance
Input	100 kΩ (I <sub>B</sub> =100 μA)	5.2 pF
output	11 MΩ (I <sub>B</sub> =100 μA)	4.6 pF



(a)

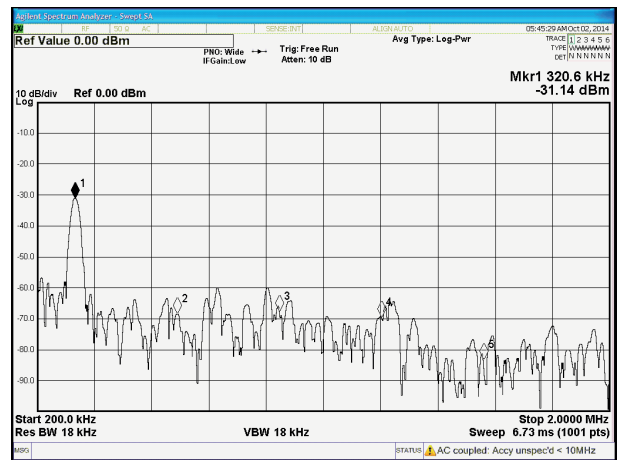


(b)

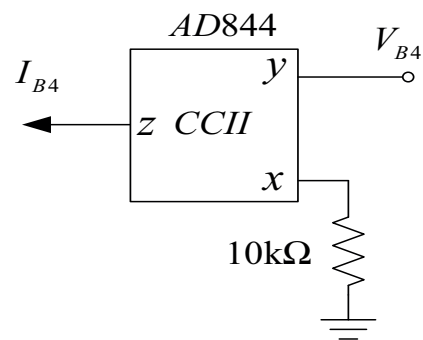
**Figure 11:** (a) The waveform of output signals ( $V_{01}$ ,  $V_{02}$  and  $V_{03}$ ), (b) The waveform between  $V_{01}$  and  $V_{02}$

## 7 Conclusion

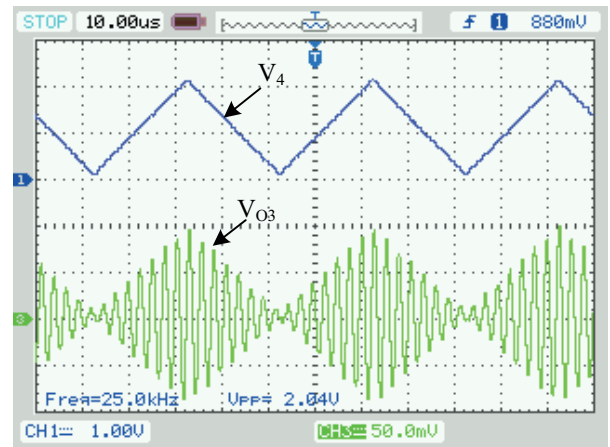
Current-mode quadrature oscillator using CCCCTAs and grounded elements has been presented. The proposed circuit consists of two CCCCTAs, two grounded capaci-



**Figure 12:** The spectrum of output signal



**Figure 13:** The V to I converter circuit



**Figure 14:** The waveform of AM signal

tors and one grounded resistor. The condition and frequency of oscillation are independently adjusted by input bias current of CCCCTAs. Due to high-output impedances, it enables easy driving load without external current buffer. In addition, the amplitude of sinusoidal output signal can be electronically tuned. Moreover, it can provide the AM/ASK signals that are widely used in communication systems [32]. The PSpice simulation and experimental results well conform to the theoretical anticipation.



## 8 References

1. A. Jantakun and W. Jaikla, "Current-mode Quadrature Oscillator based on CCCDTAs with Noninteractive Dual-current control for Both Condition of Oscillation and Frequency of Oscillation," *Turk J Elec Eng & Comp Sci*, vol. 21, pp. 81-89, 2013.
2. D. Bielek, A. Lahiri, W. Jaikla, M. Siripruchayanun and J. Bajer, "Realization of Electronically Tunable Voltage-mode/Current-mode Quadrature Sinusoidal Oscillator using ZC-CG-CDBA. *Microelectron. J.* vol. 42, pp. 1116-1123, 2011.
3. R. Šotner, Z. Hrubos, J. Slezak, and T. Dostal, "Simply Adjustable Sinusoidal Oscillator Based on Negative Three-Port Current Conveyors," *Radioengineering*, vol. 19, pp. 446-453, 2010.
4. S. A. Tekin, "Voltage Summing Current Conveyor (VSCC) for Oscillator and Summing Amplifier Applications," *Journa of Microelectronics, Electronic Components and Materials*, vol. 44, no. 2, pp. 159-167, 2014.
5. L. W. C ouch, *Digital and Analog Communication Systems*, 6th ed, Prentice Hall Inc. , 2001.
6. W. Tomasi, *Electronic Communications System*, New Jersey: Prentice-Hall Inc., 1998.
7. C. Toumazou, F. J. Lidgey and D. G. Haigh, *Analogue IC design: the current-mode approach*. London: Peter Peregrinus; 1990.
8. R. Prokop and V. Musil, "New modern circuit block CCTA and some its applications," *The Fourteenth International Scientific and Applied Science Conference - Electronics ET'2005*. Book 5. Sofia: TU Sofia, pp. 93-98, 2005.
9. M. Kumngern, J. Chanwutitum and K. Dejhan, "Fully Integrated Current-mode Quadrature Sinusoidal Oscillator Circuit," *2011 International Conference on Electrical Engineering and Informatics*, 17-19 July 2011, Bandung, Indonesia, pp. 1-4, 2011.
10. M. Kumngern and S. Junnapiya, "A Sinusoidal Oscillator using Translinear Current Conveyors," *Conference on 2010 IEEE Asia Pacific Circuits and Systems (APCCAS)*. Kuala Lumpur, Malaysia, 6-9 Dec. 2010, pp. 740-743, 2010.
11. M. Ghosh, S. Bhattacharya, A. Ranjan and S. K. Paul, "CMOS Sinusoidal Oscillator using Current Conveyor," *Proc. of Int. Colloquiums on Computer Electronics Electrical Mechanical and Civil 2011*. Kerala, pp. 142-144, 2011.
12. W. Jaikla, P. Silapan, C. Chanapromma and Siripruchayanun M., "Practical Implementation of CCTA based on Commercial CCII and OTA," *International Symposium on Intelligent Signal Proceeding and Communication Systems (ISPACS 2008)*, Bangkok, pp. 1-4, 2008.
13. A. Lahiri, "Explicit-current-output Quadrature Oscillator using Second-generation Current Conveyor Transconductance Amplifier," *Radioengineering*, vol. 18, pp. 522-526, 2009.
14. A. Lahiri, W. Jaikla and M. Siripruchayanun, "Voltage Mode Quadrature Oscillator with Current Tunable Properties," *Analog Integrated Circuits and Signal Processing*, vol. 65, pp. 321-425, 2010.
15. M. Siripruchayanun and W. Jaikla, "Current Controlled Current Conveyor Transconductance Amplifier (CCCCTA): A Building Block for Analog Signal Processing," *Electrical Engineering*, vol. 90, pp. 443-453, 2008.
16. T. Bumronghoke, W. Jaikla, and M. Siripruchayanun, "An Electronic Controllable Simple Current-mode Oscillator using Single MO-CCCCTA and Grounded Capacitors," *The 1st international conference on Technical Education*, Bangkok, pp. 217-220, 2010.
17. R. Šotner; J. Jerabek; R. Prokop and K. Vrba, "Current Gain Controlled CCTA and Its Application in Quadrature Oscillator and Direct Frequency Modulator," *Radioengineering*, vol. 20, pp. 317-326, 2011.
18. R. Šotner, J. Slezak, and T. Dostal, "Tunable Oscillator using Two CCTA-s and Only Grounded Passive Elements," *2010 9th International Conference on Environment and Electrical Engineering (EEEIC)*, Prague, pp. 447-450, 2010.
19. N. Pisutthipong, P.Silapan, and M. Siripruchayanun, "CC-CCTA Based Current-mode Quadrature Oscillator," *In Proc. The Seventh PSU Engineering Conference*, Songkla, pp. 302-305, 2009.
20. W. Jaikla, A.Noppakarn and S. Lawanwisut, "New Gain Controllable Resistor-less Current-mode First Order Allpass Filter and Its Application," *Radioengineering*, vol. 21, no. 1, pp. 312-316, 2012.
21. A. Lahiri, "Resistor-less Mixed-mode Quadrature Sinusoidal Oscillator," *International Journal of Computer and Electrical Engineering*, vol. 2, no. 1, pp. 1793-8163, 2010.
22. S. Maneewan, B. Sreewirote and W. Jaikla, "A Current-mode Quadrature Oscillator using a Minimum Number of Active and Passive Components," *2011 IEEE International Conference on Vehicular Electronics and Safety (ICVES)*, 10-12 July 2011, pp. 312-315, 2011.
23. N. Herencsar, J. Koton, K. Vrba and A. Lahiri and O. Cicekoglu, "Current-controlled CFTA-based Current-mode SITO Universal Filter and Quadrature Oscillator," *2010 International Conference on Applied Electronics (AE)*, 8-9 Sept. 2010. pp. 1-4, 2011.
24. W. Tangsrirat, P. Mongkolwai and Pukkalanun, "Current-mode high-Q Bandpass Filter and Mixed-mode Quadrature Oscillator using ZC-CFTA and Grounded Capacitors," *Indian J. of Pure & Applied Physics*, vol. 50, pp. 600-607, 2012.

25. D. Prasertsom and W. Tangsrirat, "Current Gain Controlled CFTA and Its Application to Resistorless Quadrature Oscillator," 2012 9th International Conference on Electrical Engineering/Electronics Computer Telecommunications and Information Technology (ECTI-CON), 16-18 May 2012, Bangkok, pp. 1-4, 2012.
26. D. Duangmalai and W. Jaikla, "Realization of Current-mode Quadrature Oscillator Based on Third Order Technique," *Int. J. on Electrical and Power Engineering*, vol. 2, no. 3, pp. 46-49, 2011.
27. T. Thosdeekoraphat, S. Summart and C. Thongsopa, "Current-mode Sinusoidal Oscillator using Single Dual-output Current Controlled Current Conveyor Transconductance Amplifier (DO-CCCCTA)," *Aust. J. Basic & Appl. Sci.*, vol. 7, no. 8, pp. 230-236, 2013.
28. D. Prasertsom and W. Tangsrirat, "CDBA-based Sinusoidal Quadrature Oscillator with Current Controlled Amplitude," *2010 Int. Symposium on Communication and Information Technologies (ISCIT)*, 26-29 Oct 2010, Tokyo, pp. 187-191, 2010.
29. S. Maiti and R. R. Pal, "Dual Mode Quadrature Oscillator Employing Single Current Controlled Current Conveyor Transconductance Amplifier," *Int. J. Innovative Research in Science, Engineering and Technology*, vol. 2, pp. 3015-3112, 2013.
30. R. Šotner, Z. Hrubos, B. Sevcik, J. Slezak, J. Petrzela and T. Dostal, "An Example of Easy Synthesis of Active Filter and Oscillator using Signal Flow Graph Modification and Controllable Current," *J. of Electrical Engineering*, vol. 62, no. 5, pp. 258-266, 2011.
31. R. Šotner, N. Herencar, J. Jerabek, R. Dvorak, A. Kartci, T. Dostal and K. Vrba, "New Double Current Controlled CFA (DCC-CFA) Based Voltage-mode Oscillator with Independent Electronic Control of Oscillation Condition and Frequency," *J. of Electrical Engineering*, vol. 64, no. 2, pp. 67-75, 2013.
32. M. Siriprachayanun and W. Jaikla, "Cascadable Current-mode Biquad Filter and Quadrature Oscillator using DO-CCCIIs and OTA," *Circuits Syst Signal Process*, pp. 28, 99-110, 2009.
33. AD844 60MHz 2000V/ $\mu$ s Monolithic Opamp Analog Device. Revise February 2009. [www.analog.com](http://www.analog.com)
34. LM13700/LM13700A Dual Operational Transconductance Amplifier with Linearizing Diodes and Buffers. DS007981 May 1998, [www.national.com](http://www.national.com).
35. DS1000B Series "User's Guide," Publication number UGA04106-1210. July 2008, [www.rigol.com](http://www.rigol.com)
36. N9000A CXA signal analyzer "Specifications guide," Keysight Technologies, Inc. 2009-2014.

Arrived: 18. 06. 2014

Accepted: 03. 12. 2014