

# *A Counter of Number of Products on the Shelf – Influences on Capacitance of Interdigitated Capacitor with Application in Intelligent Packaging*

*Sanja Kojić, Srđan Ajkalo, Miloš Gužvica, Dragana Vasiljević, Milan Radovanović, Goran M. Stojanović*

*Department for Power, Electronics and Communications Engineering, Faculty of Technical Sciences, University of Novi Sad, Novi Sad, Serbia*

**Abstract:** Products availability on the shelf, in the store, is a very important aspect in order to provide consumer satisfaction. Instead of conducting physical store audit, this paper demonstrates a counter of the exact number of the products on the shelf prototype realization. The complete test platform on Plexiglas has been developed. The proposed principle is based on interdigitated capacitor fabricated using ink-jet technology, where one set of silver electrodes is posted on the platform and another set on the boxes (products). When all products are on the test platform (or shelf) the capacitance has a maximum value. Taking products from the shelf this capacitance decreases and complete hardware solution has been made to transfer measured capacitance into number of products and to show this number on the display and turn on warning messages, if it is necessary. The proposed solution enables early detection of low number of products on the shelf and timely replenishment.

This paper studies performance of interdigitated capacitors printed with ink-jet printing technology on flexible substrate. Focus point of research presented in this paper is influences of different factors (number of capacitors connected in parallel, accurate position of electrodes of one capacitor, frequency range, etc.) on the capacitance of the structure. Main results are in the demonstration of capacitance change due to the influence of position between electrodes. Test platform, using this principle, has been made to demonstrate that it can be used as an effective solution for out-of-shelf problem.

**Keywords:** flexible substrate, ink-jet printing, intelligent packaging, interdigitated capacitor (IDC), silver ink.

## *Števec števila izdelkov na policah – Vplivi na kapacitivnost prepletenega kondenzatorja pri pametni embalaži*

**Izveček:** Za zadovoljstvo stranke je pomembna razpoložljivost izdelka v trgovini. Na mesto fizičnega štetja zaloge članek predstavlja prototipni števec izdelkov na polici. Razvita je bila celotna testna platforma na pleksi steklu. Predlagan princip temelji na prepletenemu kondenzatorju v ink-jet tehnologiji, pri katerem je ena srebrna elektroda tiskana na polico, druga na embalažo izdelka. Ko so vsi izdelki na testni polici, je kapacitivnost največja. Ob umiku izdelka s police se kapacitivnost zniža. Izdelana je bila celotna strojna oprema, ki izmeri kapacitivnost, jo pretvori v število izdelkov in pokaže na ekranu. Po potrebi lahko vključi tudi opozorilna sporočila. Predlagana rešitev omogoča pravočasno detektiranje zmanjkovanja izdelkov in posledično njihovo dopolnitev.

Članek opisuje učinkovitost tiskanih kondenzatorjev na gibljivo osnovo. Raziskave se osredotočajo na več faktorjev: število kondenzatorjev vezanih vzporedno, natančno pozicioniranje elektrod, frekvenčno območje itd. Glavni rezultati prikazujejo spremembo kapacitivnosti glede na razdaljo med elektrodama. Testna platforma demonstrira učinkovito uporabo pri štetju izdelkov na policah.

**Ključne besede:** gibljiva osnova, ink-jet tiskanje, pametna embalaža, prepleten kondenzator (IDC), srebrna pasta.

\* Corresponding Author's e-mail: sanjakojic@uns.ac.rs

## 1 Introduction

The problem of products missing from the shelf (or “out-of-shelf” problem) is still a frequent phenomenon in the grocery retail sector and can lead to lost sales and decreases consumer loyalty [1]. The term “out-of-shelf” (OOS) is used to describe situation where a customer does not find the product (or sufficient number of that product) one wishes to buy on the shelf of a supermarket. The reasons for the OOS are usually ordering problems and replenishing problems. Performing visual and manual inspection by store personnel is slow, expensive, and susceptible to human error. Because of that it is necessary to develop a precise product availability monitoring device or system.

Recently, some published papers suggested solutions of OOS problem through machine-learning technique [1] or classification methods [2, 3] in order to automatically identify products missing from the shelf. Apart from these approaches, there are some other technologies, which can provide product availability monitoring on retail shelves such as: radio frequency identification (RFID) [4, 5, 6], computer vision has developed powerful algorithms for pattern recognition [7], infrared sensors [8], weight-sensitive foam [9], etc.

Polymer or printed electronic is expected to be a promising technology for low-cost and large-area electronic components, circuits and systems [10]. Printed electronics industry has developed a number of processes and substrates materials to print devices at low cost [11]. This area of electronics enables easy processing possibilities with the opportunity to print inks on flexible substrates such as foils, papers, textile, etc. Interdigitated electrode (IDE) capacitors are one of the most used electronic components especially in sensors, transducers, filters, etc. Compared with parallel plates structure, the planar design of IDE is particularly suitable for manufacturing on plastic flexible substrate. Printed and polymer electronics can encourage new opportunities in the field of sensing and electronics. Humidity sensor, inkjet printed on flexible foil, based on interdigitated capacitors to allow ultra-low power consumption has already been reported [12]. Additionally, the same group was developed a differential capacitive sensors with integrated temperature sensor made on polyimide [13] or poly ethylene terephthalate (PET) [14]. Furthermore, a humidity sensor that employs interdigitated capacitors printed with silver nanoparticle based ink on a flexible PET substrate was fabricated using gravure printing process [15]. Realization of flexible strain sensor that possesses micro scale thick interdigitated capacitors with no residual layer by a simple direct stamping with silver nanoparticles has

been demonstrated in [16]. In the paper [17] has been investigated dependence of the capacitance of the interdigitated capacitor as a function of the electrode geometry and the bulk electrical properties of the substrate.

However, these systems were designed to inform personnel when the small number of the products is on the shelf (not exact number) and some of them require a robust installation on the shelves which increases integration costs or with small variation in capacitance (for example, around 50 fF in [18]). In all of these papers both sets of electrodes (fingers) of interdigitated capacitors are fabricated on the same substrate. In addition to this, analysis of influence of different position of fingers on total capacitance has not been performed, up to now.

This paper presents a complete demonstrator - a counter of explicit number of products on the shelf based on flexible/printed electronics. If the quantity of boxes (items on our platform or the shelf) is getting lower, our electronic system prototype informs employees in the store that product should be replenished, through very clear visual and voice messages. The system functionality could be extended by connecting more single product active shelf systems to the network with ability to inform an operator via network central node to take appropriate actions.

This paper also presents comprehensive analysis of influence of various positions of electrodes of interdigitated capacitor (IDC) on its capacitance. IDCs have been fabricated using silver ink on flexible Polyimide substrate, using inkjet technology. One set of electrodes was fabricated on one substrate and another set on the other substrate. In this way, it is possible to change position when one set is incorporated in fixed set of electrodes, as a basis. Consequently, different capacitance values can be achieved. Finally, application of this approach (a complete demonstrator) is presented - a counter of explicit number of products on the shelf based on flexible/printed electronics.

## 2 Design of interdigitated capacitor

Guideline for selection of dimensions of IDC were dimension of a standard pharmacist box of children syrup, which are around 5.0 cm x 5.5 cm. Structures are designed in Microsoft Visio® program and exported in .bmp picture format with resolution 1016 dpi x 1016 dpi. Exact dimensions are visible in Figure 1 and they are given in millimetres.

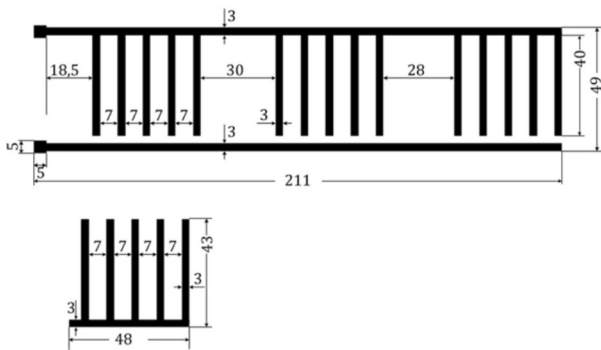

**Figure 1:** Design of IDC.

When both parts of interdigitated capacitor are in an ideal place (as shown in Figure 2), distance in vertical 10 line set is now 2 mm and gap distance is 3 mm.



**Figure 2:** Ideal position of electrodes shown for tree IDCs.

The conductive electrodes of the proposed structure of interdigitated capacitor were manufactured using Dimatix® DMP-3000 [18] cartridge based piezo ink jet printing system. Silver nanoparticle (with 20 % concentration) commercial ink (SunTronic® U5603) [19] was used as a conductive material to be printed on polyimide film substrate [20] with the thickness of 50 μm. DMP-3000 printing frequency was set on 4 kHz with nozzle voltage amplitude of 28 V, and drop space resolution of 25 μm. After printing, the structure was sintered in an oven up to 200 °C for 45 minutes. The polyimide film was selected as a substrate due to its mechanical flexibility, chemical resistant properties and thermal stability. For easier handling one part of the IDC structure is stick to the Plexiglas board (further called fixed part) as shown in Figure 3. Figure 4 shows other electrode of IDC (further called mobile part) printed in the same technology and on the same substrate as the fixed part of IDC. Wires for terminals were glued on the platform with conductive epoxy silver paste and the whole structure was connected to an instrument HP4194A Impedance/Gain Phase Analyzer to conduct measurements. Structures presented in Figure 3 and Figure 4 have identical dimensions like dimensions already depicted in Figure 1.

Figure 5 shows SEM micrograph of the cross-sectional view of the sintered silver layer indicating homogenous structure with thickness approximately 500 nm.

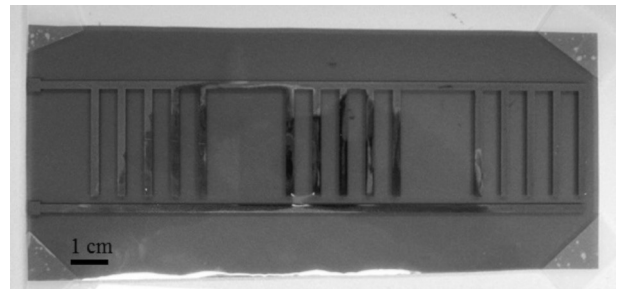

**Figure 3:** IDC fabricated on the Polyimide film using silver as a conductive material – set of tree half’s connected in parallel (fixed part).

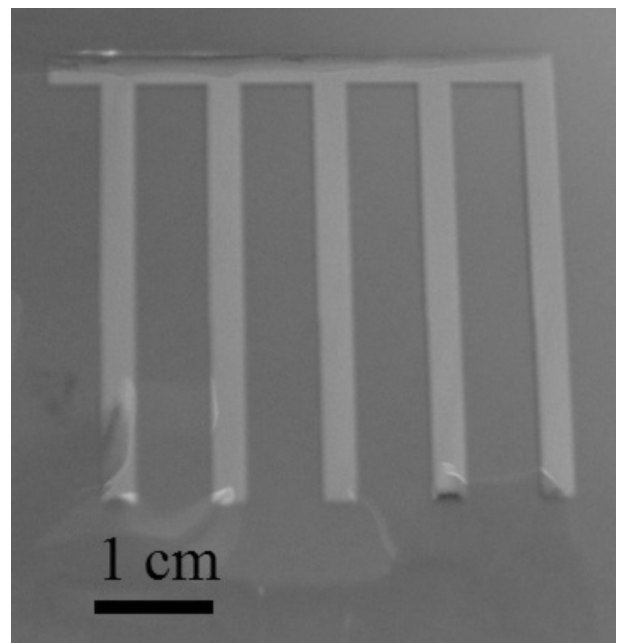

**Figure 4:** IDC fabricated on the Polyimide film using silver as a conductive material – second half of one IDC (mobile part).

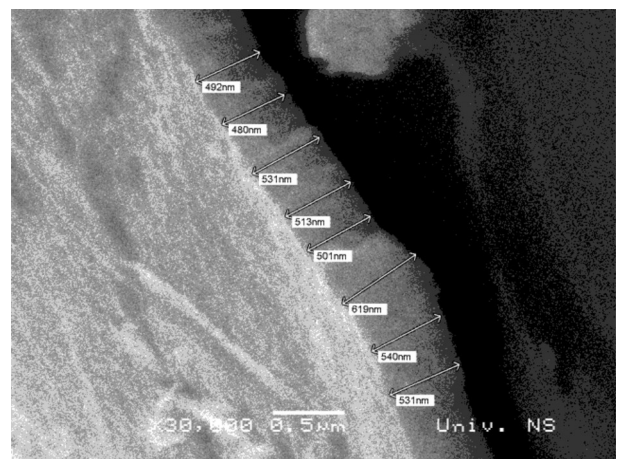

**Figure 5:** SEM micrograph of silver conductive layer.

### 3 Description of the electronic part of the system

There are several general approaches in capacitive sensors interfacing applications [21]. For measuring the IDC structure capacitance, a simple capacitance to voltage converter has been implemented. Some variations of this circuit can be found in literature as Mitchell's circuit [22]. It consists of three main blocks shown on the schematics in Figure 6.

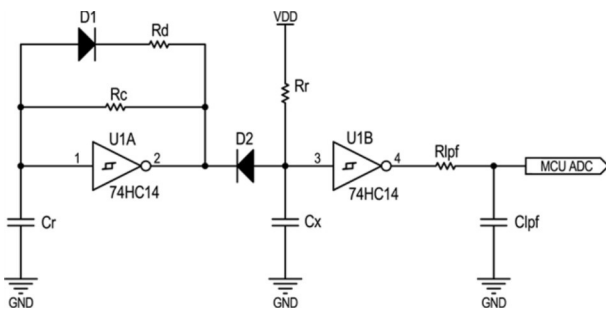

**Figure 6:** Developed capacitance measurement system schematics.

The implemented circuit can be described as a combination of an oscillator circuit and a charge-time measurement circuit. The first part of the circuit is used to generate appropriate charge/discharge interval using a relaxation oscillator with Schmitt inverter. The Schmitt inverter thresholds are fixed, so the duty cycle of the pulse-width modulation (PWM) on its output is determined by feedback resistors  $R_c$  and  $R_d$ . A diode at the output of the relaxation oscillator enables the unknown IDC structure capacitor ( $C_x$ ) to be charged during the high output state of the relaxation oscillator (while the diode  $D_2$  is reverse biased). Analogously, during the low output state of relaxation oscillator (while the diode  $D_2$  is forward biased) discharging of the  $C_x$  capacitor is enabled. The actual values of the capacitor  $C_r$  and resistor  $R_r$ , which are used as a measurement range selecting components, depend on the desired range. The obvious restriction in the selection of  $C_r$  and  $R_r$  values is that the charging interval of the  $C_x$  capacitor through  $R_r$  resistor should be smaller than charging interval of  $C_r$  capacitor through  $R_c$  resistor, thus allowing the  $C_x$  capacitor to be fully charged. The second part of the circuit produces PWM signal at the output of the second Schmitt inverter with average voltage value proportional to unknown IDC structure capacitance. Finally, a passive first order low-pass filter was applied prior to connecting to the microcontroller analog-digital converter (ADC) port.

As a part of the system for measurement data acquisition, calculation and presentation, Atmel's AVR But-

terfly microcontroller development kit was used. The AVR Butterfly board is equipped with a fast enough Atmel's ATmega169 low power 8-bit microcontroller as the main part of the system, a LCD, one ADC channel input port, two microcontroller ports connectors, a joystick, a piezo element, etc. The board comes with pre-programmed bootloader firmware allowing very easy microcontroller reprogramming via microcontroller's UART. The measurement data acquisition and presentation firmware was written in C. The main roles of firmware are measurement data acquisitions via microcontroller ADC1 (MCU PortF1) pin and data presentation. The Schmitt inverter thresholds lie within near linear part of capacitor's charge/discharge characteristic – between one and two thirds of the power supply voltage.

### 4 Building of the test platform

We have developed a prototype on a Plexiglas platform with dimension 45 cm × 20 cm × 10 cm, with 6 interdigitated capacitors (one electrode is on the Plexiglas and another is on the bottom side of the box) in 3 columns and 2 rows (Figure 7). Capacitors are connected in parallel so when the "shelf" in the store is full, the maximum capacitance is obtained and display shows the exact number of the products. In our case, the obtained capacitance was in the range from 20 pF (for six boxes) to 4.45 pF (for an empty shelf). If the quantity of boxes (items on our platform or the shelf) is getting lower, the electronic system prototype informs employees in the store that products should be restocked, through very clear visual and voice messages. The system functionality could be extended by connecting more single product active shelf systems to the network with ability to inform an operator via network central node to take appropriate actions.

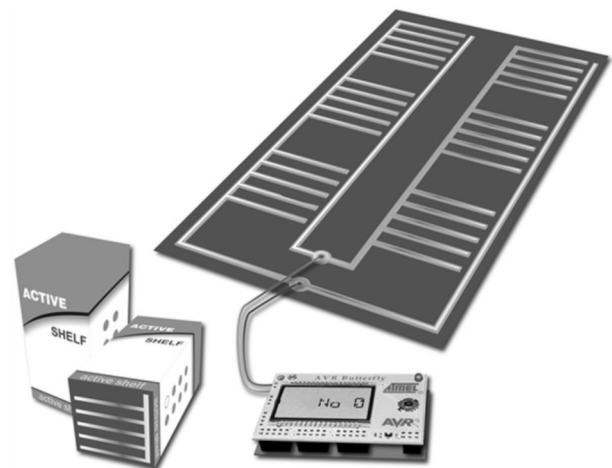

**Figure 7:** Application of IDC on intelligent packaging.



## 5 Results and discussion

Two types of influences on the capacitance of the fabricated IDC structure are analysed in this paper:

- Influence of number of capacitors in parallel on the total capacitance,
- Influence of accurate position of mobile part of IDC.
- Measurement of the two other characteristics was made (for an ideal position of the IDCs):
- Frequency dependence of capacitance and
- Values measured on the Atmel AVR ADC for different IDC capacitance values

Positioning of the structures for all cases of measurements is done under the microscope.

### 5.1 Influence of number of capacitors in parallel on the total capacitance

To demonstrate parallel connection of this type of capacitors and to determine their behaviour, three capacitors were designed. Capacitance of fixed structure exists because both contacts (square parts on the top of Figure 1) are on this part of IDC structure. Realization of complete capacitors occurs when mobile part makes the physical connection with thin line of fixed part (visible in Figure 8). This is the way we achieved free movement of mobile part.

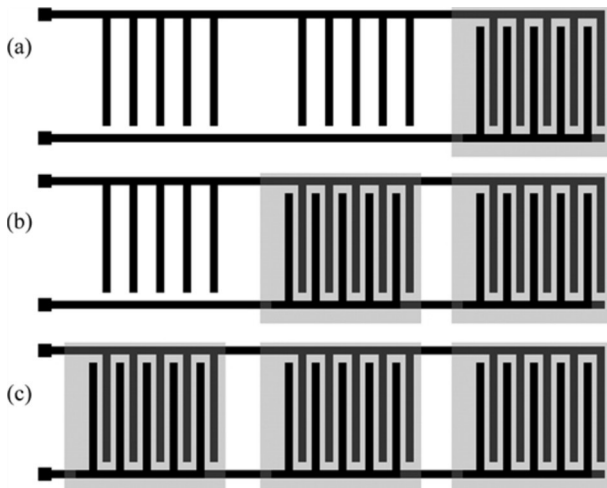

**Figure 8:** Changing the number of IDCs connected in parallel. (a) one capacitor, (b) two capacitor, (c) three capacitor

Table 1 demonstrates that capacitance rises almost linearly in steps in average of 5.7 pF per addition of one capacitor. Capacitance of fixed part shown in the top of Figure 1 is equal to 4.45 pF. Therefore, by adding mobile parts of capacitors overall capacitance rises in discrete values.

**Table 1:** Influence of number of capacitors in parallel on the total capacitance

No. of capacitors	Related Figure	Measured capacitance [pF]
0	Figure 1 (top)	4.45
1	Figure 8 (a)	10.19
2	Figure 8 (b)	15.94
3	Figure 8 (c)	21.52

Figure 8 gives an overview of increasing number of IDCs connected in parallel. Gray square marks correspond to Polyimide film of mobile electrodes. Black coloured parts resemble to visible electrodes (looking from the top), gray shadowed parts represents electrodes below the polyimide film.

Further measurement demonstrates that there is no connection between positions of capacitor and capacitance or order of setting and capacitance. Therefore, it is no matter of importance was the left, right or middle capacitor put first on the fixed part; result on full amount of capacitance is the same.

### 5.2 Influence of accurate position of mobile electrode.

Capacitance of IDC depends of the geometry of electrodes, material of electrodes, substrate and dielectric. In this sub-section, deviation of results of measured capacitance in the case of non-ideal positioning is discussed. The main reason for examination of these cases is a need for determination of differences in capacitance caused by relocation from an ideal position.

Figure 9 summarizes some extreme cases of relocations in four directions: up, down, left and right. This is maximum deviation in movement with which IDC is still working properly (that means that no short circuit is created).

**Table 2:** Changing position of one capacitor

No. of capacitors	Related Figure	Measured capacitance (pF)
1	Figure 9 (a)	11.94
1	Figure 9 (b)	12.35
1	Figure 9 (c)	12.38
1	Figure 9 (d)	10.68

Measurement results of this deviation are presented in Table 2 In consideration that one capacitor has the measured value of 10.19 pF in an ideal position, calculation evaluates that worst case scenario is when deviation is in up-right direction or in down-left direc-

tion. Hence, that capacitance of the capacitor is 12.35 or 12.38 pF. Thus, capacitance is increased for 2.19 pF maximum. From the results presented in Table 2, it can be concluded that capacitance value is higher in any case of deviation in movement in comparison with the capacitance of one IDC in an ideal position. This is a consequence of closer position of IDC fingers which has effect in increasing capacitance.

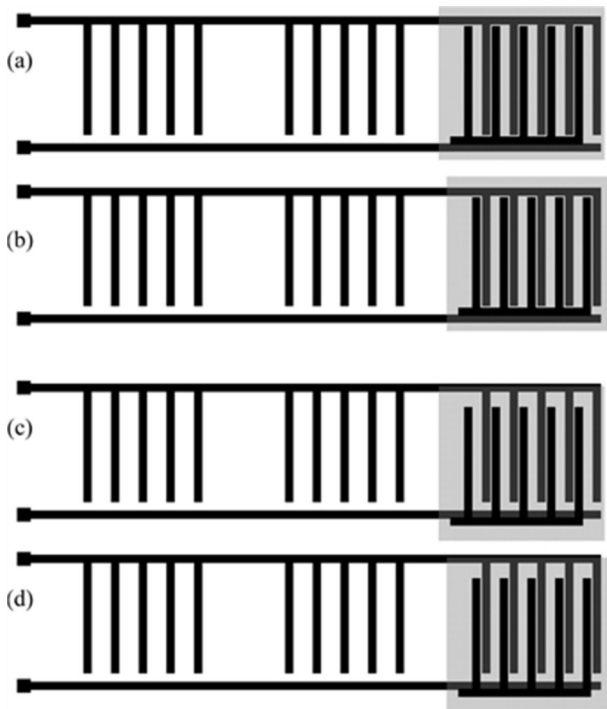
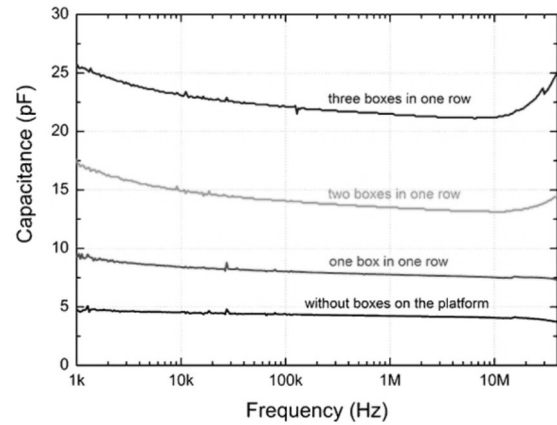

**Figure 9:** Preview of maximum deviations in movement in four directions (up-down and left-right). Displacement to the up-left corner (a); displacement to the up-right corner (b); displacement to the low-left corner (c) and displacement to the low-right corner (d).

*5.3 Frequency dependence of capacitance*

The measured results for capacitance as a function of frequency (on an instrument HP4194A Impedance/Gain Phase Analyzer), for one row of IDC without boxes as well as with one, two or three boxes (this situation is shown in Figure 8) are presented in Figure 10. As can be seen, a very good agreement is achieved between measured and analytical values for capacitance of IDC structure, without boxes on it. It is also worth mentioning that proposed IDC structure can be used in a wide frequency range. Figure 10 reveals that self-resonant frequency is far above 40 MHz, which is the maximum frequency range for the instrument HP4194A. The existence of self resonance results in some increase of capacitance for high frequencies (above 15 MHz), which is characteristic for high values of capacitance (but from practical point of view the range around 20 kHz

is of our interest). Contribution in total capacitance is higher with adding each new box, as can be seen from Figure 10, the difference between adjacent curves are higher with increasing number of boxes on the shelf. This is a consequence of lateral and additional fringing capacitances which are pronounced with more number of boxes on the shelf.



**Figure 10:** Measured capacitance as a function of frequency for different number of IDC structures formed

In the testing phase, measured values were taken at the circuit’s charge/discharge frequency, around 20 kHz.

*5.4 Values measured on the Atmel AVR ADC for different IDC capacitance values*

Figure 11 shows the values measured at Atmel AVR ADC for different IDC capacitance values, along with its linear fit and adjusted coefficient of determination value of 0.99994. The capacitance meter range components values (Rr and Cr) are chosen to allow measurement in the whole range – around 5 pF for an empty shelf to near 40 pF for all six products on our test shelf platform. This wide capacitance values range is an important advantage of our solution comparing with similar solutions in literature [14]. It can provide a very good resolution and linearity. From the other side, dimensions of whole IDC structure in tens of centimetres range (including the length and width of conductive lines) has a consequence in slightly higher consumption of silver ink during ink-jet printing. However, it is planned that cost-effective cooper ink to be used in the next improvements of presented solution including also optimization of geometry of the IDC structure. Additionally, an important further step will be printing on the box directly, using Pulse Forge machine.

Furthermore, it can be noticed that the system has a small zero bias which is considered in software. Since the removal of the product from the shelf lowers down the equivalent IDC structure capacitance, when

measured capacitance is less than the previous for the amount of threshold (a least single IDC capacitance), firmware decreases the total amount of product on the shelf, and vice versa. For the correct functioning of this approach, it is assumed that initially there is a known quantity of products on the shelf (in the reality this is usually fulfilled).

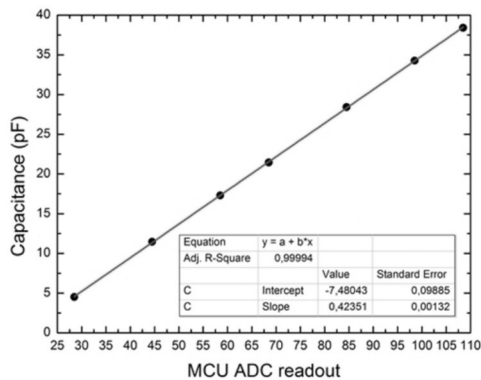
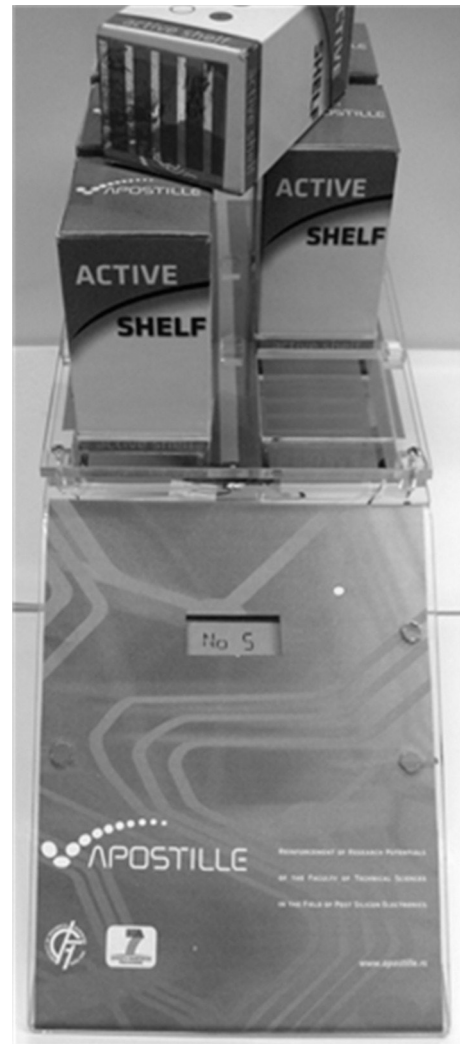

**Figure 11:** Microcontroller ADC measured values vs. IDC structure capacitances.

Between two successive capacitance readouts, firmware makes a decision upon above described scenario. If the equivalent capacitance is changed, firmware outputs the information of new quantity to the display (LCD) and informs the user of the new total number of products (Figure 12) on the shelf, by emulating the human speech. If the total number of products on the shelf is less or equal to the defined critical amount, system turns on the red LED and informs that the shelf should be replenished with products. Additionally, the text to speech system option is implemented by changing the PWM frequency on the pin connected to the AVR Butterfly piezo element and is implemented for words in English. Entered text strings are broken apart into syllables or phonemes, previously defined in program memory as an array of different PWM frequencies, which are then sent to the piezo element for appropriate syllable emulation. The proposed prototype can be supplied through a small AC/DC converter or using the battery of 9 V. The maximal current is around 20 mA, but in a normal operational mode this consumption is significantly lower.

## 6 Application

These examination of IDCs printed on flexible substrate are response of demands for smart or intelligent packaging. One of the problems in smart packaging is so called out-of-shelf (OOS) problem. This problem of products missing from the shelf is still a frequent phenomenon in the grocery retail sector and can lead to lost sales and decreases consumer loyalty [15]. The



**Figure 12:** Developed platform of the counter of the number of products on the shelf.

term “out-of-shelf” is used to describe situation where a consumer does not find the product (or sufficient number of that product) one wishes to buy on the shelf of a supermarket, during a shopping tour. It might be that product exists in the store (back-room), but it is not on shelf. The reasons for the OOS are usually ordering problems and replenishing problems. Performing visual and manual inspection by store personnel is slow, expensive, and susceptible to human error. Because of that it is necessary to develop a precise product availability monitoring device or system. Consequently, based in previously described approach we have developed a complete solution, illustrated in Figure 12, intended to solve (or minimize) OOS problem. IDC is connected with AVR system with microcontroller and display for depicting the number of boxes posted on the platform (shelf). As can be seen from Figure 12, the second part of the interdigitated capacitor structure is posted on the bottom side of the boxes (the product in the reality).

Measurements showed almost no difference between capacitance when mobile part is free and when is fixed to the boxes. For this reason we believe that there are no obstacles which consider transition from free mobile part to mobile part fixed to product for further developing of this type of IDCs.

## 7 Conclusion

This paper has presented one solution for OOS problem. Existing solution is suitable for upgrades in area of wireless connection, advertising and so on.

This paper has presented a structure of interdigitated capacitor printed using ink-jet technology on flexible substrate. The proposed solution of interdigitated capacitor was printed on different substrates where on set of electrodes is fixed to the Plexiglas platform and another set of fingers free (or glued on the box or packaging). The silver electrodes of IDC have been fabricated on flexible Polyimide film by means of ink-jet printer (Dimatix DMP-3000). Mechanical flexibility of Polyimide substrate enables that proposed solution can have a wide range of applications. The total capacitance of IDC decreases with decreasing number of products on the shelf. Influences of: number of IDCs connected in parallel and position of electrodes were examined in detail. The complete electronic system for conversion of measured capacitance range to the number of products (presented on the display) has been developed. If the total number of products on the shelf is less or equal to the defined critical amount, system has visual and oral warnings that shelf should be replenished. The proposed system can accurately anticipate "out-of-shelf" situations and inform the store personnel before this situation occurs.

## 8 Acknowledgment

This work is partly supported within the project TR32016 and the equipment provided within the FP7 APOSTILLE project, no. 256615, financed by EC.

## 9 References

1. D. Papakiriakopoulos, K. Pramataris, G. Doukidis, "A decision support system for detecting products missing from the shelf based in heuristic rules", *Decision Support Systems*, vol. 46, pp. 685-694, 2009.
2. D. Papakiriakopoulos, G. Doukidis, "Classification Performance for making decisions about products missing from the Shelf", *Advances in Decision Sciences*; article ID 515978, 13 pages, 2011.
3. D. Papakiriakopoulos, "Predict on-shelf product availability in grocery retailing with classification methods", *Expert Systems and Applications*; Volume 39, Issue 4, pp 4473-4482, 2012.
4. Wijesiriwardana R, Mitcham K, Dias T, "Fibre-meshed transducers based real time wearable physiological information monitoring system" *Proceedings of the Eighth International Symposium on Wearable Computers (ISWC'04)*, Arlington, 2004.
5. Singh S P, McCartney M, Singh J., Clarke R. RFID Research and Testing for Packages of Apparel, Consumer Goods and Fresh Produce in the Retail Distribution Environment *Packaging Technology and Science*; 21 pp 91-102, 2008.
6. Tellkamp C "The impact of Auto-ID technology on process performance – RFID in FMCG supply chain" *Dissertation No. 3182*, University of St. Gallen, Switzerland, 2005.
7. Bai R "An investigation of novel approaches for optimising retail shelf space allocation" *PhD thesis*; University of Nottingham, 2005.
8. Feller S D, Cull E, Kowalski D, Farlow K, Burchett J, Adleman J, Lin C, Brady D J *Tracking and Imaging Humans on Heterogeneous Infrared Sensor Array for Law Enforcement Applications*; SPIE Aerosense, 2002.
9. C. Metzger, J. Meyer, E. Fleisch, G. Tröster, "Weight-Sensitive Foam to Monitor Product Availability on Retail Shelves", A. LaMarca et al. (Eds.): *Pervasive 2007*,
10. K. Bock, G. Klink, C. Strohhofer, D. Hemmetzberger, M. Feil, "Large Area Cost-Efficient Electronics Systems Integration," *Electronic Components and Technology Conf.*, Sparks, Nevada, pp. 1540-1543, 2007.
11. D. Briand, F. Molina-Lopez, A. V. Quintero, C. Ataman, J. Courbat, N. F. de Rooij, "Why Going Towards Plastic and Flexible Sensors," *Procedia Engineering*, vol. 25, pp. 8-15, 2011.
12. F. Molina-Lopez, D. Briand, N. F. de Rooij, "All additive inkjet printed humidity sensors on plastic substrate," *Sensors and Actuators B*, vol. 166-167, pp. 212-222, 2012.
13. A. Oprea, J. Courbat, N. Barsan, D. Briand, N. F. de Rooij, "Temperature, humidity and gas sensors integrated on plastic foil for low-power applications," *Sensors and Actuators B*, vol. 140, pp. 227-232, 2009.
14. F. Molina-Lopez, A. Vasquez Quintero, G. Matana, D. Briand, N. F. de Rooij, "All-additive Inkjet Printed Humidity and Temperature Sensors Fabricated and Encapsulated at Foil Level," *The 14th*



- International Meeting on Chemical Sensors – IMCS 2012, pp. 1122–1125, 2011.
15. A. S. G. Reddy, B. B. Narakathu, M. Z. Atashbar, M. Rebros, E. Rebrosova, M. K. Joyce, "Fully Printed Flexible Humidity Sensor," *Procedia Engineering*, vol. 25, pp. 120–123, 2011.
  16. J. Kim, K. Wubs, B. S. Bae, W. S. Kim, "Direct stamping of silver nanoparticles toward residue-free tick electrode," *Science and Technology of Advanced Materials*, vol. 13, 035004 (6pp), 2012.
  17. P. M. Harrey, P. S. A. Evans, B. J. Ramsey, D. J. Harrison, "Interdigitated capacitors by offset lithography," *Journal of Electronics Manufacturing*, vol. 10, no. 1, pp. 69-77, 2000.
  18. [www.dimatix.com](http://www.dimatix.com)
  19. [www.sunchemical.com](http://www.sunchemical.com)
  20. [www.gts-flexible.co.uk](http://www.gts-flexible.co.uk)
  21. K. Bull, "Methods of Accurately Measuring Capacitive RH Sensors," 5th Int. Symp. On Humidity and Moisture - ISHM'2006, Rio de Janeiro, Brazil, May 02-05, 2006.
  22. S. Truong, "Design of a Handheld Skin Moisture Measuring Device for Application towards Eczema," EE 4BI6 Electrical Engineering Biomedical Capstones, Paper 15, 2009.

Arrived: 13. 04. 2014

Accepted: 25. 08. 2014