

CHARGING STATIONS CONNECTED TO STREET LIGHT POWER SYSTEMS

POLNILNE POSTAJE PRIKLJUČENE NA ELEKTROENERGETSKI SISTEM ULIČNE RAZSVETLJAVE

Peter Janiga[✉]

Keywords: street lighting, public lighting, charger, charging station, power quality, electric vehicle, lamp, luminaire

Abstract

Street light grids are dense and compact networks in all cities. They power the luminaires and elements of smart cities. Recently, they have also been used to power chargers for electric vehicles. The article analyses how charging stations can be connected to public lighting networks, and gives knowledge about connecting the charger and optimising operations to increase the power delivered to vehicles. Initial installations show that the combination of luminaires, public lighting networks and chargers shows specific characteristics. The aim of the paper is to provide knowledge about the implementation of chargers in street light grids. The last part of the paper presents the results a case study, which is focused on voltage drops and limits for installing charging stations.

Povzetek

Elektroenergetski sistemi za ulično razsvetljavo so gosta in kompaktna omrežja v vseh mestih. Napajajo svetila in elemente pametnih mest. V zadnjem času se uporabljajo tudi za napajanje polnilnic električnih vozil. Članek analizira, kako lahko polnilne postaje priključimo na omrežja javne razsvetljave, podaja znanja o priklopu polnilnika in optimizaciji delovanja za povečanje moči, ki se pretaka v vozila. Začetne inštalacije kažejo, da kombinacija svetilk, omrežij javne razsvetljave

[✉] Corresponding author: Assoc. Prof., Peter Janiga, Slovak University of Technology in Bratislava, Faculty of Electrical Engineering and Information Technology, Ilkovičova 3, 84104 Bratislava, Tel.: +421 2 6029 1811, E-mail address: peter.janiga@stuba.sk

in polnilnic kaže specifične značilnosti. Namen prispevka je podati znanje o implementaciji polnilnic v omrežja javne razsvetljave. Zadnji del prispevka predstavlja rezultate študije primera, ki se osredotoča na padce napetosti in omejitve za namestitev polnilnih postaj.

1 INTRODUCTION

Street light grids (SLG) are the main parts of cities and municipalities. They are on all the streets. They are a network that covers the entire city and allows smart city elements to be powered. A specific feature of an SLG is that the main appliance (luminaire) is switched on only at night. These properties create possibilities for the use of SLG to power charging stations for electric vehicles. There are already several projects in the world, but there is not enough experience and information on how to build and operate these common networks [9].

Charging modes

In relation to the method of connecting the vehicle to the power network, the EN 61851-1 [1] Standard defines four possible connection modes.

- Mode 1 - In this case, a standardised socket with a nominal current value not exceeding 16A is used to connect to the AC supply voltage network. It can be a single-phase socket with a nominal voltage of 230V, or a three-phase socket with a nominal voltage of 400V, in both cases with a protective earth conductor.
- Mode 2 - In this case, a standardised socket with a rated current value not exceeding 32A is used to connect to the AC supply voltage network. It can be a single-phase socket with a nominal voltage of 230V, or a three-phase socket with a nominal voltage of 400V, in both cases with a protective earth conductor. The difference from mode 1, in addition to the rated current, is the need to use a charge control circuit with separate electrical protection in this case. The circuit is integrated directly into the control box of the charging cable, which must be at a distance of 0.3m from the plug, or directly on it.
- Mode 3 - Is charging through a device reserved only for charging electric vehicles. The device is connected permanently to the AC power supply. It is necessary to use a charging control circuit that communicates with the device (charging station) during the entire charging period.
- Mode 4 - In the first three modes charging was carried out using the vehicle's on-board charger. The fourth mode uses a charger located outside the vehicle's deck to connect the vehicle to the power network. The charger can be powered from an AC or DC network. However, the standard is to be powered by an AC current, which must be converted to a DC current in a charging station outside the vehicle. Even in this case, communication is necessary, where the charging control circuit communicates with the public charging station during the entire charging period.

The method of charging electric vehicles and their integration into the distribution grid can have a significant impact on the energy system. In the case of high-power charging at fast-charging stations with high capacity, managing substantial amounts of electrical energy simultaneously may necessitate adjustments in the distribution grid. Peak load management is crucial, as the current collective surge in charging can create peak loads on the grid. Implementing an intelligent charging infrastructure that can optimise charging based on the current state of the grid is essential. The development of technologies and strategies for electric vehicle charging plays a crucial role in the pursuit of a sustainable and efficient integration into the energy system.

2 METHODS

The calculation methodology is based on the definition of boundary conditions such as operating charging stations in general and existing public lighting networks. The charging stations are divided into AC and DC. This division determines the output power of the charger. Charging stations with an AC current are typically slower than DC stations [8]. Charging with an AC current can be divided into two groups: slow charging with a power of up to 3.7kW, and accelerated charging with a power of 3.7kW to 22kW. When charging with a DC current, we are talking about fast and ultra-fast charging. Fast DC charging is considered to be charging with a power of up to 100kW, while the power of fast charging stations is usually not less than 50kW. Ultra-fast DC charging is charging with a power of more than 100kW.

2.1 Connecting the stations to the street light grids

Although the implementation of charging stations in the SLG is a relatively new topic, there are already several ways to connect and control the station [2]. However, everything depends on the possibilities and current capacity reserves of the SLG, because public lighting is always a primary functionality that cannot be influenced negatively by other additional appliances.

2.2 Implementation of a charging station on a pole

Connecting the charging station to a public lighting pole can be done in two ways. The first of them is the connection of a charging station in the form of a wall box to an existing pole. The second is the integration of the charging station directly into the public lighting pole. This solution is better for networks with reconstructed poles, where it is expected to replace the original poles with new ones. This solution is not visually disturbing, and the public lighting pole looks the same as ordinary poles, except that it contains a charging connector. The third solution is to place the charging station in a separate column. This solution is suitable if there is no pole near or for parking spaces. However, there must be a public lighting cable nearby to power the charging station. From the point of view of installation, this solution is suitable for more extensive renovations, where cable lines are also replaced.

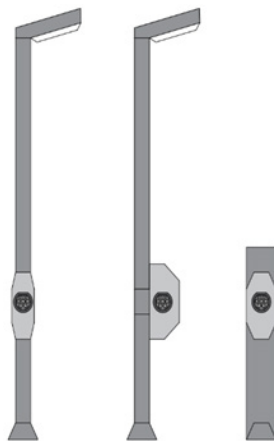

Figure 1: Charging station integrated to the pole (right), charging station in the form of a wall box (middle), charging station in a separate column

In all cases, as with all public AC charging stations, the Type 2 connectors defined in EN 61851-1 are used as standard.

2.3 Electrical connection of the charging station

From the point of view of connecting the power line, there are several ways to implement charging stations in the SLG.

The first of them is the connection of the charging station to the power line that is common to public lighting. In this case, intelligent control is necessary, that corrects the maximum power of the charging station based on the current state of the network, so as not to limit the public lighting function. Depending on the possibilities of the network, different capacities of charging stations can be used, up to charging stations with a power of 22kW when supplied from three phases.

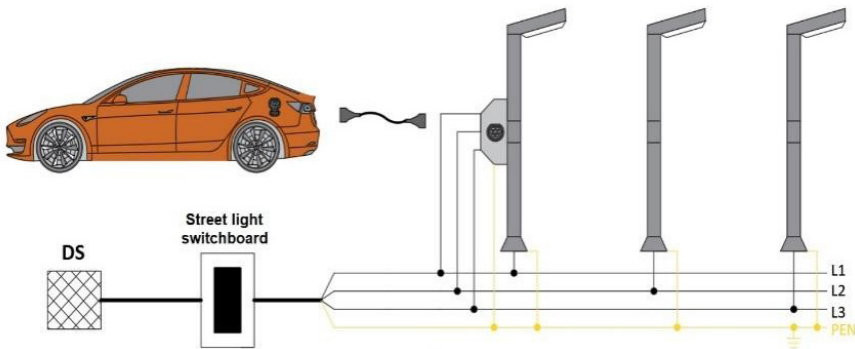

Figure 2: Connection of the charging station to the power line common with the power supply of the SLG

The second option is to connect the charging station to only one phase of the three-phase system. This phase is reserved for the power supply of the charger and other appliances (e.g. smart city appliances). In this case, public lighting luminaires are powered from the remaining two phases of the three-phase system. A disadvantage with this connection is the unbalanced load on the phase system and a lower charging power for the user, which is around 7kW (for 230 V).

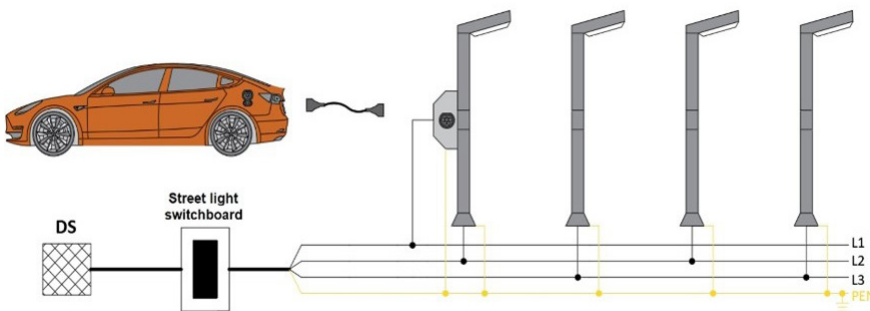

Figure 3: Connecting the charging station to the reserved one phase of the three-phase system

Another option is the use of two independent three-phase power lines. One is used exclusively to power the public lighting network, and the other to power charging stations or other additional appliances. This method is advantageous to realise only in case of complex reconstructions of SLG, where old power lines are replaced with new ones. The advantage is that the maximum charging power is always available. It is given by the maximum current carrying capacity of the branch and the used charging stations. The power of the charging stations is independent of the lights. This, of course, applies if the power line of the public lighting switchboard is sized for the maximum charging power of the lamps and charging stations in the branches.

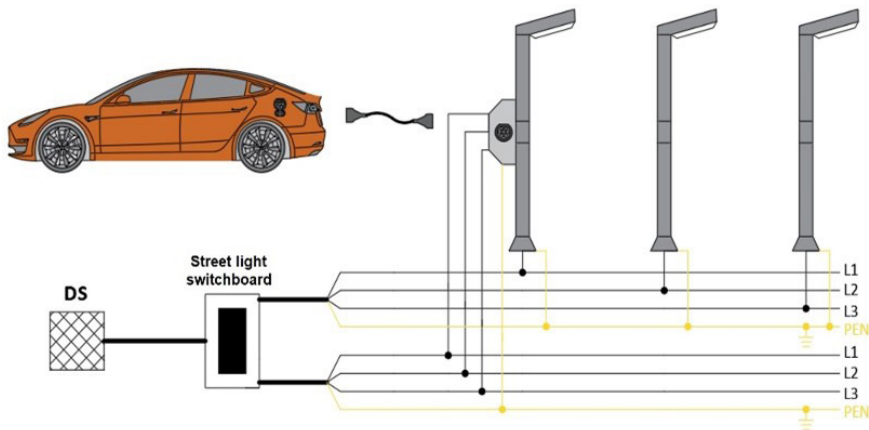

Figure 4: Charging station powered from a separate power line

A specific case of the previous option is the connection of an SLG line and a line for charging stations at their ends. This creates a two-side power supply system, which can have a positive effect, for example, to reduce voltage drops, but this system requires luminaires with remote switching on the system.

2.4 Voltage drop

The design of an SLG requires taking care of voltage drop, because it has long distance of power line. The same holds for the implementation of charging stations, but the power load is higher. There is no general Standard that defines the maximum value of the voltage drop in the SLG. The EN 50160 [4] Standard defines a specific voltage deviation of $\pm 10\%$, which, at a nominal voltage of 230 V, is in the range of 207 V to 253 V. However, this Standard is only for distribution grids, and defines the SLG voltage only at the power supply point. In Slovakia, the STN 332130 [3] Standard defines the maximum voltage drops for building a lighting installation. Due to the similar indoor appliances and public lighting, it is used in practice as an approximate problem in the calculation of voltage drops in the public lighting network. According to this Standard, the voltage drop in the SLG does not exceed 4% of the nominal voltage from the switchboard to the appliances.

2.5 Calculation of voltage drop

There are several ways to calculate voltage drops. In the calculations, a simplification is used so that the entire load is at the end of the line. This simplification represents the worst possible

situation. For the following calculations, relation (2.1) is from STN 332130, which is for three-phase circuits. This is adjusted to relation (2.2), because the goal of the calculation is to determine the maximum lengths of the power lines by using standard cable cross-sections and a maximum voltage drop of 4% of the nominal voltage value.

$$\Delta U = \frac{\sqrt{3} \cdot I \cdot l \cdot PF}{\gamma \cdot S} \tag{2.1}$$

$$l = \frac{\Delta U \cdot \gamma \cdot S}{\sqrt{3} \cdot I \cdot PF} \tag{2.2}$$

Where:

- γ – wire conductivity
- ΔU – voltage drop
- S – cross-section of wire
- l – length of line
- I – current in power line
- PF – power factor

The result of the calculation is a graph showing the standard copper (CYKY) and aluminium (AYKY) cable lines used in public lighting networks. It is considered with their maximum current capacity and location in the ground.

In the next graph, the CYKY-J 4x10 means a cable with copper core with 4 wires, where 3 wires are for phases, and one is for PEN (neutral N together with protective earth PE). The cross-section is 10 square millimetres.

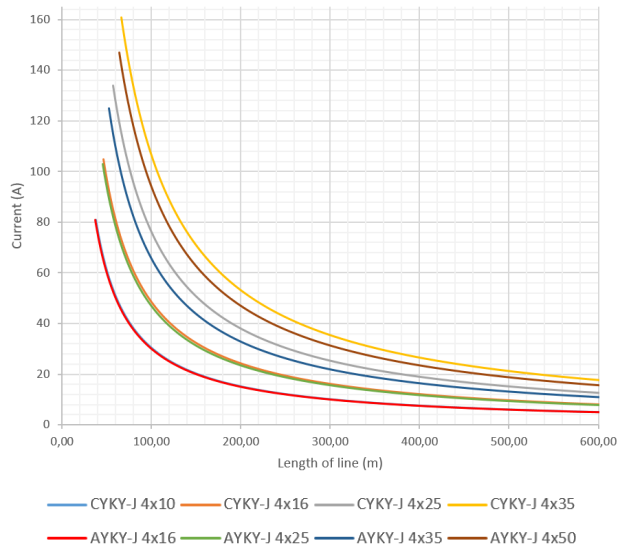

Figure 5: Dependence between maximum current and length of line for 4% voltage drop and variable cables. Copper (CYKY) and aluminium (AYKY)

In the graph, the CYKY-J 4x10 means a cable with a copper core with 4 ,where 3 wires are for phases, and one is for PEN (neutral N together with protective earth PE). The cross-section is 10 square millimetres

3 RESULTS

The case study deals with several variants of connecting charging stations to the public lighting network. It determines how far from the SLG switchboard the charging stations can be connected, or how many can be placed in a branch with different cable lines, and the voltage drop is no higher than 4% of the nominal voltage. In this case study, all variants were based on the complex formula (3.1) to calculate the voltage drop. It takes into account the distribution of the current load I_i in the chosen distances of the branch l_i , based on the sum of the current moments.

$$\Delta U = \frac{\sqrt{3} \cdot \sum_{i=1}^m I_i \cdot l_i \cdot PF}{\gamma \cdot S} \quad (3.1)$$

In Tab. 1 and Tab. 2 are the maximum lengths of cable lines from the switchboard, where the charging station can be placed, and the voltage drop has not exceeded the Standard requirements (4%). For the first variants the powering is from one phase according to Fig. 6.

Table 1: Maximal length of line – variant 1

One charger 3.7kW (1x16A, 230V) connected to one phase without luminaires								
Wire	CU 4x10	CU 4x16	CU 4x25	CU 4x35	AL 4x16	AL 4x25	AL 4x35	AL 4x50
Max. length of line (m)	190	304	474	664	188	293	411	587

Table 2: Maximal length of line – variant 1

One charger 7.4kW (1x32A, 230V) connected to one phase without luminaires								
Wire	CU 4x10	CU 4x16	CU 4x25	CU 4x35	AL 4x16	AL 4x25	AL 4x35	AL 4x50
Max. length of line (m)	95	152	237	332	94	147	205	293

In this case the charger uses different phase like luminaires. The current in the phase is independent on the luminaires`operation. The length for a 7.4kW charger is shorter, equivalent to the power.

The third variant is powered according to Fig. 7. In this case there are luminaires with an input power of 50 W every 25 metres for a typical situation [7]. The charger and luminaires are connected to all three phases. In this case, we try to simulate the operation with luminaires. The length is calculated only for one charger with full power.

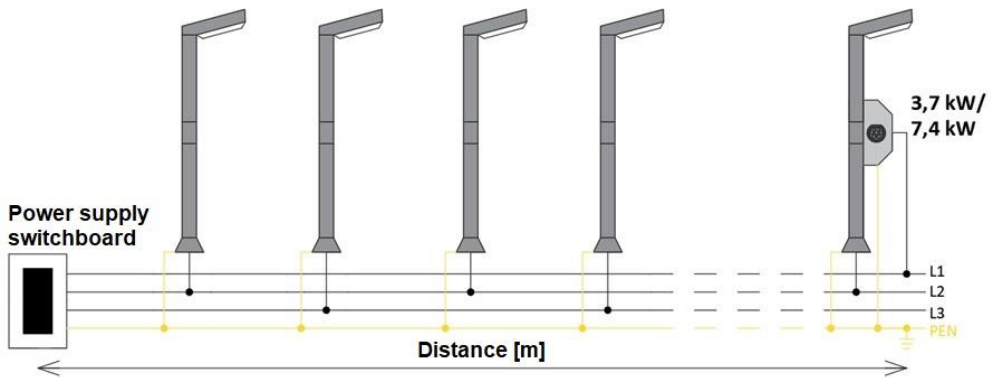

Figure 6: Connection of charger for variant 1 and 2 (charger a different phase like luminaires)

Table 3: Maximal length of line – variant 3

One charger 22kW (3x32 A) connected to three phases with luminaires every 25m								
Wire	CU 4x10	CU 4x16	CU 4x25	CU 4x35	AL 4x16	AL 4x25	AL 4x35	AL 4x50
Max. length of line (m)	94	149	233	326	93	144	202	287

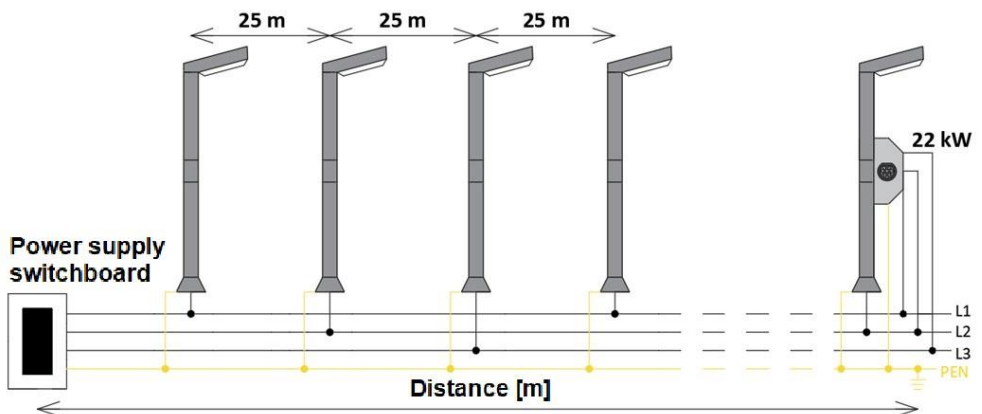

Figure 7: Connection of charger for variant 3 and 4 (luminaires are on)

The fourth variant has the same wiring as the third, but the charging station is located at half the distance compared to the third variant.

Table 4: Maximal length of line – variant 4

One charger 22kW (3x32 A) connected to three phases with luminaires every 25m, with the charger connected in the middle of the line								
Wire	CU 4x10	CU 4x16	CU 4x25	CU 4x35	AL 4x16	AL 4x25	AL 4x35	AL 4x50
Distance to charger (m)	47	74,5	116,5	163	46,5	72	101	143,5
Max. length of line (m)	925	1225	1525	1825	925	1225	1450	1750

4 DISCUSION

Comparing the second and third variants, we see that the distance difference when using the power line is minimal. So, in the model example, it does not make a significant difference whether the charging station is powered from a dedicated phase that does not power the lights, or is powered from a phase that powers the lights in addition to the charging station. The reason is that the power consumption of luminaires is significantly less than the consumption of the charger. A more significant difference can occur if the consumption of the lights is comparable to the power input of the charger (e.g. old luminaires with high consumption).

The aim of the fourth variant is to show that the maximum length of the power lines is increasing significantly when the charging station is moved from the end of the branch (variant 3) to half the distance (variant 4). Because the charging station is an appliance with a significantly higher power consumption compared to modern LED luminaires, the total lengths of the branches in variant 4 are, in some cases, up to 10 times larger than in the case of variant 3.

Dependence between the number of chargers and the distance from the switchboard

In terms of load, a 7.4kW charging station connected to one phase is equivalent to a 22kW charger connected to three phases. In both cases, the power per phase is the same. Tab. 5 shows how many chargers can be installed at distances of 50, 100, 200 and 300 metres from the switchboard. The consumption of luminaires is not taken into account. In residential areas, the consumption of LED lamps is significantly less than the consumption of the charging station [5].

The closer the charging stations are to the switchboard the more there can be. Cross-sections CU10 and AL16 are not suitable for maximum load (7.4kW one phase or 22kW three phase) and have limited options for powering the light. If it were necessary to install charging stations at distances greater than 200 metres, it would be worth considering the use of even larger cable conductor cross-sections than those shown in Tab 5.

Table 5: Number of chargers without luminaires

Maximum number of chargers (7.4kW one phase or 22kW three phase) without luminaires								
Wire	CU 4x10	CU 4x16	CU 4x25	CU 4x35	AL 4x16	AL 4x25	AL 4x35	AL 4x50
50m from switchboard	1	3	4	5	1	2	3	4
100m from switchboard	0	1	2	3	0	1	2	2
200m from switchboard	0	0	1	1	0	0	1	1
300m from switchboard	0	0	0	1	0	0	0	0

There is a possibility to increase the number of charging stations in the branch and increase the sum of installed power of the charging stations, but this requires intelligent control, that redistributes the available current capacity for the charging stations [6]. During simultaneous charging of electric vehicles from several charging stations in the branch, it is necessary to limit their output power, so that the current capacity of the branch is not exceeded.

The last example is the consideration of a 500m long branch. This branch contains luminaires every 25m. The connection is implemented as in Fig. 7. The first charging station is located at a distance of 25m and each subsequent 25m further.

Table 6: Number of chargers for a 500m line

Number of 22kW chargers in a 500m line with 100W luminaires every 25m. The chargers are connected in distance of 25, 50, 100, 150m								
Wire	CU 4x10	CU 4x16	CU 4x25	CU 4x35	AL 4x16	AL 4x25	AL 4x35	AL 4x50
Number of chargers	2	2	3	4	2	2	3	4

Tab 6 shows how many chargers can be connected to a 500m line. When the chargers are every 25m, which means every pole, there can be only 2 to 4 chargers, but relatively close to the switchboard (25m to 100m). The result is that the charger is not easy to connect at a long distance from the switchboard on an existing SLG.

5 CONCLUSION

Currently, there are several professional and scientific articles focused on charging stations. However, the charging stations associated with the SLG operation are addressed minimally. The goal was to provide comprehensive information about charging station operation and implementation methods. It can be connected to existing networks, as well as newly built ones. The electrical connection can be single-phase or multi-phase. The choice of a suitable solution depends on the chargers used, and also the method of operation of the SLG. This paper provides a description of the theoretical level, and a case study focused on the issue of the distance

between the charging stations and the switchboard (or power supply point). Because charging stations have a significant consumption compared to luminaires, inappropriate placement and connection of the charging station can shorten the power line. The calculations consider the nominal power of the charging stations. By using charge management (reducing the input power of the charger), the number of installed chargers increases, but, on the other hand, the charging time increases.

As part of research on this topic the authors have carried out several measurements. The results were processed step by step, and will be published in the following publications. The aim of these measurements will be for providing a base to the theoretical level and showing the risks and potential of SLG in connection with charging stations.

ACKNOWLEDGMENT

This paper is supported by the agency VEGA MŠVVaŠ SR under Grant No.: VEGA1/0390/23.

References

- [1] EN 61851-1 *Electric vehicle conductive charging system. Part 1: General requirements*
- [2] EN 62196-1 *Plugs, socket-outlets, vehicle connectors and vehicle inlets - Conductive charging of electric vehicles - Part 1: General requirements*
- [3] STN 33 2130 *Electric engineering regulations. Internal electric distribution lines*
- [4] EN 50160 *Voltage characteristics of electricity supplied by public electricity networks*
- [5] **T. Novak, J. Sumpich, J. Vanus, K. Sokansky, R. Gono, J. Latal, P. Valicek:** *A model for predicting energy savings attainable by using lighting systems dimmable to a constant illuminance*, (2020) Lecture Notes in Electrical Engineering, 554, pp. 860 – 869 DOI: 10.1007/978-3-030-14907-9_83
- [6] **L. Kuncicky, T. Novak, K. Sokansky, Z. Slanina:** *Road Lighting Control Options*, (2019) Proceedings of 44th WILGA Symposium on Photonics Applications and Web Engineering, Wilga, POLAND, MAY 26-JUN 02, 2019, DOI: 10.1117/12.2536886
- [7] **J. Škoda and M. Motyčka:** *Lighting Design Using Ray Tracing*, 2018 VII. Lighting Conference of the Visegrad Countries (Lumen V4), 2018, pp. 1-5, doi: 10.1109/LUMENV.2018.8521111.
- [8] **C. Suarez and W. Martinez:** *Fast and Ultra-Fast Charging for Battery Electric Vehicles – A Review*, 2019 IEEE Energy Conversion Congress and Exposition (ECCE), 2019, pp. 569-575, doi: 10.1109/ECCE.2019.8912594.
- [9] **T. Chen et al.:** *A Review on Electric Vehicle Charging Infrastructure Development in the UK*, in Journal of Modern Power Systems and Clean Energy, vol. 8, no. 2, pp. 193-205, March 2020, doi: 10.35833/MPCE.2018.000374.