

## Sigilata s Školaric pri Spodnjih Škofijah Trgovina s sigilatnim posodjem v severni Istri v 1. in 2. st.

Tina ŽERJAL

### Izvleček

Avtorica predstavi sigilatno gradivo iz 1. in 2. st. n. št. z izkopavanj vile rustike na Školaricah pri Spodnjih Škofijah. Večina sigilatnega gradiva izhaja iz bližnjega padskega prostora, čeprav so prisotni tudi redki primerki aretinske sigilate. V zadnji četrtini 1. stoletja se servisom italske tere sigilate pridruži in jih deloma izpodrine uvožena vzhodna sigilata B iz Male Azije. Takšna slika je značilna za širši severnojadranski prostor. S pomočjo sigilate smo datirali začetek vile v drugo četrtino ali sredino 1. st. n. št.

**Ključne besede:** Slovenija, Istra, Školarice, rimska doba, vila rustika, 1.-2. st., sigilata, trgovina

### Abstract

The author presents the sigillata ware from the 1<sup>st</sup> and 2<sup>nd</sup> centuries that was discovered during the excavation of the *villa rustica* at Školarice near Spodnje Škofije. Most of the sigillata ware, with rare examples of Arretine sigillata, originates from the nearby Po region. The services of Italian sigillata are later, during the last quarter of the 1<sup>st</sup> century, joined and partially ousted by the imported eastern sigillata B from Asia Minor. Apart from Školarice, this development is characteristic for a broader northern Adriatic region. The examined sigillata was also instrumental in dating the villa's beginnings to the second quarter or the mid 1<sup>st</sup> century AD.

**Keywords:** Slovenia, Istria, Školarice, Roman Age, *villa rustica*, 1<sup>st</sup> to 2<sup>nd</sup> centuries, *terra sigillata*, trade

### UVOD

Ob gradnji avtocestnega odseka Klanec-Sermin so bila leta 2002 na Školaricah pri Spodnjih Škofijah izvedena zaščitna arheološka izkopavanja<sup>1</sup> (Trenz et al. 2002; Trenz, Novšak 2004; Novšak 2003b). Rimske najdbe so bile tu prvič dokumentirane v začetku 90. let pri terenskih pregledih Giordana Labuda (1995, 51), ki se je natančneje ukvarjal s topografijo Rižanske doline. Pomembnost najdišča je bila nato potrjena s primarnimi arheo-

loškimi raziskavami (intenzivni terenski pregled, geofizikalne meritve in testno sondiranje) pred izgradnjo avtoceste.

Na spodnjem delu pobočja hriba Bečajevec, na Školaricah, je bil tako odkrit obsežen arhitekturni kompleks vile rustike z bivalnim in gospodarskim delom. Večina rezidencialnega poslopja na jugu je bila žal popolnoma uničena pri gradnji tovarne Iplas v 60. letih 20. stoletja. Na drugih območjih so bile arheološke plasti zaradi intenzivne kmetijske obdelave in izdelave teras v novem veku raz-

<sup>1</sup> Ta prispevek je del postopka analize izkopanega gradiva, ki bo skupaj s stratigrafskimi podatki v celoti ovrednoteno v monografiji zbirke *Arheologija na avtocestah Slovenije*. Zahvaljujem se Alfredu A. Trenzu (ZVKD Slovenije, OE Piran) in Matjažu Novšaku (Arhej, d. o. o.), ki sta mi prijazno zaupala obdelavo keramičnega gradiva. Za kritično branje in konstruktivne pripombe se zahvaljujem doc. dr. Vereni Vidrih Perko (Gorenjski muzej, Kranj), mentorju izred. prof. dr. Božidarju Slapšaku (Oddelek za arheologijo, Filozofska fakulteta v Ljubljani) in predvsem raziskovalni mentorici dr. Jani Horvat (Inštitut za arheologijo ZRC SAZU). Večino risb gradiva je izdelala Dragica Kinific Lunder (Inštitut za arheologijo ZRC SAZU), manjši delež je prispevala Katarina Vladimirov pod vodstvom Simone Tomažič (Arhej, d. o. o.). Skeniranje sta izvedla Lučka Šoberl in Drago Valoh (Inštitut za arheologijo ZRC SAZU), karto pa je izdelala Mateja Belak (Inštitut za arheologijo ZRC SAZU). Besedilo je v angleščino prevedla Andreja Maver. Prispevek je nastal v sklopu usposabljanja mlade raziskovalke na Inštitutu za arheologijo ZRC SAZU, ki je financirano s strani Ministrstva za visoko šolstvo, znanost in tehnologijo.

lično ohranjene. Ponekod so bile uničene skoraj do matične osnove, drugje, predvsem na notranji strani zidov za terase, pa so se dokaj dobro ohranile. V zahodnem delu kompleksa je bil odkrit termalni del, ohranjen le v temeljih pod nivojem hodne površine. Raziskana je bila tudi večina gospodarskega dela vile na severu, ki obsega večji skladiščni prostor z notranjim stebriščem in sklop manjših prostorov.

Prva analiza drobnega gradiva kaže, da je vila živila od druge četrtine oz. sredine 1. do sredine 5. st. n. št. (glej spodaj).

Nekoliko dvignjena lega stavbe na vznožju hriba je nudila panoramski razgled na celoten Koprski zaliv z gričem Sermin v ospredju in predvsem na rodovitno ravnico doline Rižane, kjer so verjetno potekale najpomembnejše gospodarske aktivnosti posestva.

Vila leži na desnem bregu reke Rižane - *Formio*, ki je po Pliniju (N. H. III, 127) predstavljala staro mejo Italije. Avgust je nato konec 1. st. pr. n. št. mejo prestavil na reko Rašo - antično *Arsio* v vzhodni Istri (osnovno delo Degrassi 1954, 54-60; sinteza kasnejših mnenj Vedaldi Iasbez 1994, 39, 44-45, 127-128, 419, in predvsem Starac 1999, 15, 57-60). Ko je bila vila na Školaricah zgrajena, je bila meja Italije torej že nekaj desetletij globoko v Istri, ager mesta Tergesta pa proti jugu razširjen do reke Mirne (Margetič 1979-1980; Lettich 1979; Zaccaria 1992, 163-164; Vedaldi Iasbez 1994, 422; Starac 1999, 110-119).

Vila je ležala sorazmerno blizu Tergesta (8 km), s katerim je imela odlično prometno povezavo. Pod vznožjem griča je namreč vodila glavna istrska prometnica med Tergestom in Polo. Rimljani so

gotovo izkoristili staro prazgodovinsko traso. Verjetno je bila rimska cestna mreža v Istri vzpostavljena kmalu po osvojitvi ter predvsem z nastankom kolonij in municipijev v drugi polovici 1. st. pr. n. št. (Šonje 1991, 9-10, 38; Matijašič 1998, 418-419). *Via publica* med Trstom in Pulo, imenovana *Via Flavia*, je bila urejena po odloku Vespazijana in Tita v letih 78-79 n. št., kakor pričajo miljniki na jugu istrskega polotoka (*Inscr. It. X*, 1, 705-706; Bosio 1991, 223). Natančen potek ceste na območju Rižanske ravnice pod Školaricami je bil potrjen z izkopavanji pozimi 2002/2003. Pri tem sta bila odkrita cestna priključka v smeri Ankarana in vile na Školaricah ter rimsko grobišče ob cesti (Trenz et al. 2003; Novšak 2003a).

Na začetku obdelave celotnega keramičnega gradiva z izkopavanj vile na Školaricah smo analizirali sigilatno gradivo iz 1. in 2. st. n. št. Fina keramika, h kateri poleg sigilate prištevamo tudi keramiko tankih sten, je bila oblikovno pod močnim vplivom kovinskega posodja. Posredno so se na njej odražale tudi kulturne in družbene razmere ter trgovski tokovi. Medtem ko so bile za kuhinjsko keramiko zaradi njene funkcionalnosti in nereprezentančnosti značilne daljša tradicija, večja stabilnost in odpornost proti novim elementom, je bilo fino namizno posodje podvrženo hitrejšim spremembam (Galli 2001, 225). S študijem sigilatnega posodja kot časovno občutljivega blaga smo želeli v začetni fazi obravnave najdišča odgovoriti na vprašanja: kdaj je bila vila zgrajena ter kako je bil širši prostor vpet v gospodarske tokove zgodnjega cesarskega obdobja. Popolna slika življenja vile bo nedvomno mogoča le z analizo vseh vrst keramike in drugih drobnih najdb skupaj s stratigrafijo in arhitekturo.

Zaradi dolgotrajne poselitve vile in slabe ohranjenosti arheoloških plasti v prenekaterih delih je zgodnje sigilatno gradivo le fragmentarno ohranjeno. Največjo koncentracijo sigilate opazimo na območju term (sektorji 0, 26 in 27) in v prostorih jugovzhodno od velikega skladišča (sektorja 7 in 8). V velikem skladiščnem prostoru (deli sektorjev 5-7, 9-11) sigilatnega gradiva ni bilo, medtem ko je bila sigilata le maloštevilna v prostorih vzhodno od njega (sektorji 11-13), kjer so verjetno potekale gospodarske aktivnosti vile. Ker trenutno še ne moremo predstaviti zaprtih sklopov z izpovednim materialom iz zgodnjega obdobja, smo se oprli na vse diagnostične kose<sup>2</sup> sigilatnega posodja (*tab. 1*).

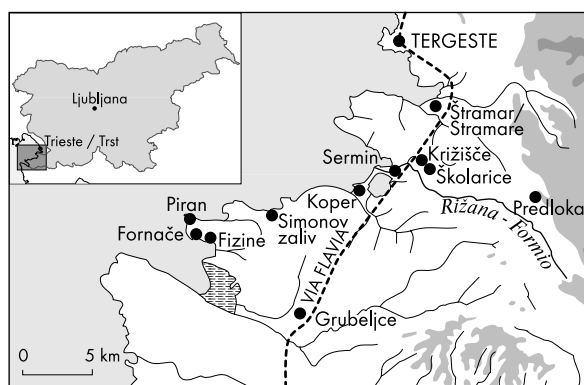

Sl. 1: Lega Školaric in pomembnejših rimskih najdišč v bližini (M. Belak).

Fig. 1: The location of Školarice and other important Roman sites in the vicinity (M. Belak).

<sup>2</sup> Za statistične in analitične potrebe smo iz celotnega korpusa izločili vse odlomke ustij, ročajev, držajev, dna ter ornamentiranih ostenij. Med neobdelanim gradivom ostajajo tako le neokrašena ostenja, za katera menimo, da ne bi bistveno spremenila razmerij med različnimi vrstami keramike.

Tab. 1: Prikaz količinskih vrednosti različnih vrst sigilate iz 1. in 2. st. na Školaricah.<sup>3</sup>Table 1: Quantitative presentation of the various types of sigillata ware from the 1<sup>st</sup> and 2<sup>nd</sup> centuries at Školarice.

Vrsta sigilate <i>Type of sigillata</i>		Ocena maksimalnega števila posod / <i>Estimated maximum number of vessels represented</i>		Ocena minimalnega števila posod / <i>Estimated minimum number of vessels represented</i>	
		n	%	n	%
<b>Aretinska sigilata</b> <i>Arretine sigillata</i>		7	4,1	5	4
<b>Severnoitalska sigilata</b> <i>North-Italian sigillata</i>	Padaska sigilata B <i>North-Italian sigillata B</i>	39	22,9	28	22,6
	Poznopadska sigilata <i>Late North-Italian sigillata / sigillata Tardopadana</i>	62	36,5	45	36,3
	Severnoitalska reliefna sigilata Sarius <i>Relief-decorated North-Italian sigillata - Sarius cup</i>	22	12,9	12	9,7
<b>Vzhodna sigilata B2</b> <i>Eastern sigillata B2</i>		40	23,5	34	27,4
Skupaj <i>Together</i>		170	100	124	100

**ITALSKA SIGILATA<sup>4</sup>**

Italaska tera sigilata je med keramiko 1. in 2. st. na Školaricah najštevilčnejša skupina finega sigilatnega posodja z 72,6-odstotnim deležem (tab. 1 - vrednosti ocene minimalnega števila posod). Značilna je za zgodnje obdobje življenja v vili. Skromen delež pripada aretinski sigilati, uvoženi iz srednje Italije, medtem ko je bila večina izdelana v delavnicah bližnje Padske nižine. To ne preseneča, saj sigilata severnoitalske proizvodnje v obdobju 1. st. in prve polovice 2. st. prevladuje na celotnem severnojadranskem prostoru (Makjanič 1989, 61; Maggi 2001). Med gradivom s Školaric so bili prepoznani tako odlomki padske sigilate B (it. *sigillata Padana B*) iz prve polovice 1. st., sočasne severnoitalske reliefne sigilate (it. *sigillata nord-italica decorata*) kakor tudi t. i. poznopadske sigilate (it. *sigillata Tardopadana*) iz druge polovice 1. in prve polovice 2. st.

**Aretinska sigilata<sup>5</sup>**

Aretinska sigilata predstavlja le majhen del (4 %) sigilatnega gradiva iz najdišča na Školaricah. Z makroskopskimi opazovanji ne moremo ločiti primerkov, izdelanih v samem Arezzu, in tistih iz drugih sorodnih centrov srednje Italije (npr. iz Pise). Tovrstna keramika je prihajala na severni Jadran najverjetneje preko najbližjega dela zahodne jadranske obale, Riminija, Adrije in Ravenne. Možni sta tako direktna povezava z obalnimi istrskimi mesti kakor posredniška vloga Akvileje kot glavnega distribucijskega centra (Maggi 2001, 149, 158).

Najstarejši primerek aretinske sigilate je odlomek ustja konične skodelice oblike Consp. 22.1 (t. 1: 1). Tovrstne skodelice so v več različicah izdelovale vse glavne delavnice sigilate med drugim desetletjem 1. st. pr. n. št. in drugim ali tretjim desetletjem 1. st. n. št. Peresni okras na trodelnem profiliranem ustju je značilen za omenjeno oblikovno varianto, ki je bila med vsemi najbolj razširjena (Consp. 1990, 90).

<sup>3</sup> Vrednosti smo dobili na osnovi vseh diagnostičnih kosov. Te smo najprej razporedili v skupine odlomkov (ang. *sherd families*), ki nedvomno pripadajo isti posodi. Nato smo jih faktorno in tipološko opredelili. Ocena maksimalnega števila posod predstavlja tako največje možno število posod, iz katerih bi lahko izvirali odkriti odlomki. Kadar odlomki iste oblike in fakture nimajo skupnih lomov, predvidevamo, da izvirajo iz različnih posod. Ocena minimalnega števila posod pa temelji na predpostavki, da odlomki iste oblike in fakture pripadajo isti posodi, dokler ni izrecno dokazano, da gre za dve različni posodi (Millet 1979, 77; Orton 1989, 94). V analizi, ki sledi, dosledno uporabljamo vrednosti minimalnega števila posod.

<sup>4</sup> Izraz uporabljamo za celotno sigilatno proizvodnjo antične Italije.

<sup>5</sup> S pojmom aretinska sigilata razumemo Fakturo A, kot jo je definirala Maria Schindler, ki je sigilato na Štalenski gori ločila po makroskopskih lastnostih gline, premaza, svojstvenih oblikovnih značilnostih posod in žigih proizvajalcev (Schindler, Scheffenegger 1977, 17).

Cilindrična skodelica oblike Consp. 26.2 (*t. 1: 2*) ima ostenje okrašeno z žlebovi. Datiramo jo v prvo polovico 1. st., saj se na Štalenski gori skodelice oblike Consp. 26 sporadično pojavijo na prelomu stoletja, pogostejše pa so predvsem v kontekstih v obdobju 20/25 - 45 n. št. (Schindler, Scheffenegger 1977, 205; Consp. 1990, 98).

Odlomek ustja *t. 1: 3* verjetno pripada krožniku z zaobljenim robom ustja in stopničastim prehodom oblike Consp. 6.2, ki sodi v poznoavgustejsko do klavdijsko obdobje (Schindler-Kaudelka, Fastner, Gruber 2001, 143). Kakor pri sočasnih krožnikih oblike Consp. 4.6 je Schindlerjeva (1977, 131) na Štalenski gori domnevala morfološki razvoj iz nizkih, zelo odprtih oblik z majhnim ustjem in poudarjeno nogo k višjim oblikam, z ustjem nagnjenim navznoter in močnejše zaobljenim zunanjim profilom ter višjo in ožjo nogo. Kasnejše analize so to tezo potrdile le za aretinske produkte (Schindler-Kaudelka, Fastner, Gruber 2001, 129). Torej bi lahko naš odlomek *t. 1: 3* tipološko uvrstili med zgodnje primerke.

Krožniki so bili na notranji površini dna pogosto okrašeni s koleščkanim peresnim okrasom. Odkriti odlomki (*t. 1: 4*; in neobjavljeni kosi) bi tako lahko pripadali oblikam Consp. 4 ali 18-21 iz poznoavgustejsko-tiberijskega do klavdijskega obdobja ali poznejšim krožnikom Consp. 3 (Consp. 1990, 148).

Najmlajša primerka iz aretinskih delavnic (*t. 1: 5,6*) pripadata krožnikom s pokončnim robom ustja oblike Consp. 20.4. Aretinske delavnice so jih izdelovale v času med Tiberijevo in Neronovo vladavino, v posameznih primerih pa se pojavljajo do konca 1. stoletja. Okrašeni so z apliciranim okrasom, kar jih loči od izdelkov padskih delavnic. Rob ustja tovrstnih krožnikov je krasilo po 8 aplik z različnimi motivi, npr. z motivom palmovih listov

z girlandami (*t. 1: 5*; Schindler-Kaudelka, Fastner, Gruber 2001, 127, 143).

### Severnoitalska sigilata<sup>6</sup>

Lončarske delavnice v Padski nižini so nemudoma sledile aretinskim vzorom. Najkasneje v zadnji četrtini 1. st. pr. n. št. priključijo izdelavi keramike s črnim premazom tako še novo tehniko izdelave rdečega sigilatnega posodja. Proizvodni centri še niso znani. Na podlagi potrjenih delavnic keramike s črnim premazom, najdb lončarskih odpadkov rdeče sigilate, kalupov in lončarskega orodja lahko lončarske delavnice padske sigilate domnevamo v mnogih padskih mestih. Severnoitalska proizvodnja je namreč zelo heterogena. Zajema zelo kvalitetne izdelke iz dobro prečiščene gline z dobrim bleščečim premazom, ki se le težko ločijo od aretinskih, in na drugi strani zelo porozne primerke z razredčenim nebleščečim premazom ter vse vmesne stopnje (Mazzeo Saracino 2000, 38).

Kemično-mineraloške analize so pokazale jasne razlike v sestavi med aretinsko in severnoitalsko sigilato. Slednja je narejena iz glin, bogatih s kalcijevim karbonatom, kar je značilnost sedimentov celotne Padske nižine. Med severnoitalsko proizvodnjo sigilatnega posodja so na osnovi vsebnosti drugih kemičnih elementov ločili nekaj različnih skupin. Na gradivu s Štalenske gore sta bili po oblikovnih in makroskopskih značilnostih jasno določeni fakturi padske sigilate B in C, za kateri se je izkazalo, da imata enako kemično sestavo. Fakturne skupine ne predstavljajo torej nujno različnih izvornih območij surove gline, temveč lahko le razlike v postopku izdelave, od same izbire gline v okolici delavnice in njene priprave, postopka sušenja

<sup>6</sup> Z izrazom *severnoitalska sigilata* zajemamo celotno sigilatno proizvodnjo v severni Italiji iz zgodnjega in srednjega cesarskega obdobja: padsko sigilato, poznopadsko sigilato in severnoitalsko reliefno sigilato. Večinoma vanjo ne prištevamo kasnejših sigilatnih proizvodenj, ki tudi niso predmet tega prispevka. Posamezne proizvodnje v mnogih objavah niso izrecno ločene, v starejših delih celo celotna severnoitalska proizvodnja ni ločena od ostale italske sigilate.

Za keramiko, za katero predlagamo ime *padska sigilata*, se v strokovni literaturi uporablja več izrazov: v it. - *terra sigillata Padana*, *sigillata Padana* ali *terra sigillata norditalica (liscia)*, *Padana B*, *Padana C* (npr. Mazzeo Saracino 1985; id. 2000; Consp. 1990, 8-10; Brogiolo, Olcese 2000); ang. - *North-Italian Plain Sigillata* (Makjanič 1989), *North Italian Sigillata* (Kenrick 2000), *Padanian sigillata* (Vidrih Perko, Pavletič 2000) ali *sigillata Padana* (Kenrick 2000; Schneider 2000a); nem. - *Padanische Sigillata* ali *Padana* (Schindler-Kaudelka, Fastner, Gruber 2001); fran. - *les sigillées padanes* (Schindler-Kaudelka, Schneider, Zabehtlicky-Scheffenegger 1997); hrv./srb. - *padanska terra sigillata* (Brukner 1981, 18-19); slov. - *padanska terra sigillata* (Istenič 1987), *padanska sigilata* (Vičič 1997; Vidrih Perko 1997, 349), *severnoitalska sigilata* (Horvat 1997).

Za *poznopadsko sigilato*, kot jo imenujemo tukaj, je S. Zabehtlicky-Scheffenegger (1992, 415) po analogiji s poznaitalsko sigilato oz. v it. *terra sigillata tar-do-italica* vpeljala termin *Terra sigillata tar-do-padana (TSTP)* ali krajše *Tardopadana*. V slovenščini jo je J. Istenič (1999, 90) prevedla kot *poznopadanska terra sigillata*, medtem ko se v drugih jezikih ohranja italijanski izraz.

Izraz *severnoitalska reliefna sigilata* je uporabila že J. Horvat (1997, 168), čeprav se v slovenščini večinoma omenjajo le skodelice ali čaše *Sarius* in kozarci ali čaše *Aco* (npr. Vičič 1997, Stokin 2001). V tuji literaturi jo najdemo pod termini: *terra sigillata norditalica decorata* (Mazzeo Saracino 1985), *ceramica norditalica decorata* (Schindler-Kaudelka 2000), *produzione padana decorata*, *ceramica tipo Aco* ali *ceramica tipo Sarius* (Mazzeo Saracino 2000, 39), *die Modelkeramik* (Schindler-Kaudelka 1980; ead. 1998), *Relief-decorated North-Italian sigillata* (Brusič 1999).

ter predvsem od načina, temperature in dolžine žganja. Kemična sestava padske sigilate B in C se ujema tudi s severnoitalsko keramiko s črnim premazom, in sicer s t. i. porozno fakturo (*Poröses Fabrikat*) iz Štalenske gore.<sup>7</sup> Poznopadska sigilata ima svojo jasno določeno kemično skupino, ki je prav tako zelo široka in trenutno nedeljiva na podskupine (lahno izstopa le faktura E).<sup>8</sup> V proizvodnji severnoitalske reliefne sigilate so bile definirane tri različne kemične skupine. Dvoročajne skodelice Sarius predstavljajo eno skupino, medtem ko sta se med kozarci vrste Aco pokazali celo dve kemično različni skupini (Schindler-Kaudelka, Schneider, Zabehlicky-Scheffenegger 1997; Schneider 2000a; Schindler-Kaudelka, Fastner, Gruber 2001, 169-176).

Na osnovi arheometričnih analiz materiala iz Bologne, Riminija in Štalenske gore je M. Picon določil 8 skupin severnoitalske sigilate in domneval 20 do 30 delavnic (Picon 1994, 54).<sup>9</sup> Vsaj nekatere delavnice keramike s črnim premazom so nadaljevale proizvodnjo rdeče sigilate, verjetno predvsem na območju osrednje Padske nižine. Po vulkanskih mineralih, prisotnih v padski sigilati B in C so bili predvideni kot možna območja proizvodnje Evganejski griči, gričevje med Verono in Vicenzo ter območje južnih pritokov Pada v okolici Modene ali Piacenze (Zabehlicky-Scheffenegger, Sauer 2000, 73; primerjaj s Picon 2000). Proizvodne centre poznopadske sigilate domnevajo v okolici Ticina na osnovi nekaterih oblik, ki se pojavljajo le na tem območju (Mazzeo Saracino 2000, 39).

Pestrost lončarskih delavnic v širšem severnoitalskem prostoru dopolnjujejo tudi lokalne delavnice na obrobju, kakršna je bila v Loronu v Istri v avgustejsko-tiberijskem obdobju (Maggi 2001). Lete so lahko zadovoljevale le potrebe posestva, zagalele okoliško tržišče ali tudi kupce v nekoliko širšem regijskem prostoru. V avgustejskem obdobju je bila uporaba izdelkov delavnice v Loronu omejena zgolj na vilo. V tiberijskem obdobju so bili namenjeni prodaji tudi na nekoliko širšem področju, saj so bili žigosani izdelki te delavnice najdeni na grobišču na Socerbu (Maggi 2002), v Akvileji, Tergestu, Poli in Emoni (Maggi 2001, 130).

Medtem ko je aretinska sigilata razširjena po celem Sredozemlju in predvsem v zahodnih provincah, je prostor razprostranjenosti padske sigilate nekoliko drugačen. Izdelki z žigi njenih proizva-

jalcev prevladujejo na območju celotne Padske nižine, pogosto so zastopani v severovzhodnih provincah (Recija, Norik, Panonija), po celi jadranski obali in naprej do Korinta in Knossosa. Posamezni primerki se pojavljajo tudi v zahodnem Sredozemlju - v severni Afriki, Siciliji in Španiji, kar pa verjetno ni odraz stabilne trgovske mreže (Kenrick 2000).

Med najstarejšimi primerki padske sigilate B na Školaricah najdemo oblike, ki so bile prevzete po vzorih aretinskih lončarjev že v začetku proizvodnje - v zadnji četrtini 1. st. pr. n. št. Velikokrat so lončarji osnovno obliko nekoliko spremenili. Nekoliko groba različica koničnih skodelic oblike Consp. 22.6 (*t. I: 9*) je tako značilna prav za padsko proizvodnjo. Začetek izdelave sega v konec 1. st. pr. n. št., kakor pri aretinski proizvodnji doseže vrh v avgustejskem in konec v poznem tiberijskem obdobju (Mazzeo Saracino 1985, 197; Consp. 1990, 90; Oberosler 1995, 287-289).

Približno sočasna je proizvodnja razvite oblike krožnikov z navpičnim konkavno-konveksnim robom ustja Consp. 18.2 (*t. I: 7,8*), le da se v Padski nižini pojavljajo v kontekstih od konca 1. st. pr. n. št. do srede 1. st. n. št. (Mazzeo Saracino 1985, 198; id. 2000, 35; Lavizzari Pedrazzini 1985, 341, op. 5, 344; Oberosler 1995, 290; Consp. 1990, 82 - datacija drugačna od ostalih - le do tiberijskega obdobja).

Konične skodelice z navznoter ukrivljenim ustjem oblike Consp. 24.3 (*t. I: 10,11*) so bile prav tako posebnost padskih delavnic od srednjeavgustejskega do klavdijskega obdobja (Mazzeo Saracino 1985, 197; Consp. 1990, 94; Oberosler 1995, 287-288). Številčno so najbolj zastopane v avgustejsko-tiberijskih kontekstih, npr. v kompleksu IV na Štalenski gori iz zgodnjega obdobja Tiberijeve vladavine (Schindler, Scheffenegger 1977, 115-119). Po žigih domneva M. Volonté (1996, 107-108) njihovo izdelavo v delavnicah na obalah severnega Jadrana.

Nekatere oblike aretinske in padske sigilate iz druge četrtine 1. st. so prevzeli tudi lončarji poznopadske sigilate. Nova pridobitev je uporaba apliciranega okrasa, ki se na aretinski sigilati pojavi že na prehodu stoletja, medtem ko ga na padski sigilati B in C lončarji nikoli ne uporabijo (Schindler-Kaudelka, Fastner, Gruber 2001, 151). Tudi na Školaricah so te "skupne" oblike prisotne tako v

<sup>7</sup> Za definicijo faktur padske sigilate glej Schindler, Scheffenegger 1977, 18-19; Zabehlicky-Scheffenegger, Sauer 2000.

<sup>8</sup> Za definicijo posameznih faktur poznopadske sigilate glej Grünwald 1983, 11; Schindler-Kaudelka 1995, 65-66; Schindler-Kaudelka, Groh 1995, 358-359; Schindler-Kaudelka, Fastner, Gruber 2001, 120-125.

<sup>9</sup> Pri tem gre za celotno severnoitalsko sigilatno proizvodnjo zgodnjega cesarstva.

padski sigilati B kot v poznopadski sigilati.<sup>10</sup> Proizvodnji se deloma oblikovno in časovno prekrivata.

Te oblike poznopadske sigilate, ki so sedaj okrašene z aplikami, je S. Zabehlicky-Scheffenegger (1992, 415-416) uvrstila v oblikovno skupino A. Najstarejši izdelki skupine (natančneje faktura D) se pojavijo že na Štalenski gori tik pred opustitvijo naselbine okoli leta 50 (Schindler, Scheffenegger 1977, 20; Schindler-Kaudelka, Fastner, Gruber 2001, 152-153). Izjemno številčni so v kontekstih flavijskega obdobja, ko njihov delež močno presega ostale poznopadske oblike. V večjem številu so prisotni še v vsakem sloju iz prve četrtine 2. st. in šele v drugi četrtini začne količina upadati, tako da v Noriku v plasteh sredine 2. stoletja najdemo le še posamične primerke (Schindler-Kaudelka, Fastner, Gruber 2001, 153). Proizvodnja najpogostejših oblik (krožnikov Consp. 20.4, skodelic Consp. 29 in skodelic Consp. 34) je nedvomno trajala še dolgo v 2. st., saj najmlajši primerki pripadajo grobnim celotam iz časa Antonina Pija. V drugi polovici 1. st. so postopoma opuščali izdelavo manj priljubljenih oblik. Oblike krožnikov Consp. 4.6 in 6.2 se pojavljajo vsaj še v flavijskih grobovih, krožniki oblike Consp. 21 v trajanskih in skodelice Consp. 27 v hadrijanskih grobovih. Torej lahko za zadnji dve obliki domnevamo izdelavo vsaj do konca 1. st. (Zabehlicky-Scheffenegger 1992, 420-423, 442).

Za večino oblik skupine A je značilno, da se v celotnem obdobju izdelave ne spreminjajo. Prav tako ne moremo razločiti variant, ki bi bile značilne za različne lončarske delavnice (Schindler-Kaudelka, Fastner, Gruber 2001, 127, 152-153). Njihova razprostranjenost obsega celotno Padsko nižino, severni Jadran ter predvsem najdišča ob glavnih kopenskih in rečnih trgovskih poteh provinc Norika in Panonije (Zabehlicky-Scheffenegger 1992, 419).

Najštevilčnejši odlomki severnoitalske sigilate na najdišču Školarice pripadajo skodelicam z rebrom oblike Consp. 34 (17,4 % severnoitalske sigilate za vrednosti minimalnega števila posod; 4 primerki v padski sigilati in 11 v poznopadski sigilati). Primerki iz padskih delavnic (*t. 3: 1*) se pojavijo v tiberijskem obdobju, so redki in vedno neokrašeni. V poznopadski proizvodnji (*t. 3: 2-8*) so te skodelice številne in značilne predvsem za vzhodni del njene razprostranjenosti - za severni Jadran, Norik in Panonijo (Consp. 1990, 112; Zabehlicky-Scheffenegger 1992, 419). Izdelovali so jih v dveh velikostih: male

(*acetabulum*) s premerom 7-9,5 cm ali prostornino nekaj čez osminko litra in velike (*paropsis*) s premerom 11-13 cm ali prostornino četrtinke litra (Schindler-Kaudelka, Fastner, Gruber 2001, 138-139). Na Školaricah (*t. 3: 1-8*) prevladujejo večje, kar pa zaradi fragmentiranosti najdb ni vedno popolnoma zanesljivo. Posodice so lahko na zunanji po-vršini roba ustja okrašene s 4 ali 6 aplikami. Aplikacije male maske s kratkimi lasmi t. i. glave satirov (*t. 3: 3*), najdemo le na poznopadskih skodelicah Consp. 34. Z aplikacijami maske z dolgimi lasmi in diademom so tvorile par, ki so ga lahko kombinirali še s pari delfinov ali dvojnih spiral (Schindler-Kaudelka, Fastner, Gruber 2001, 72-73).

Krožniki s pokončnim robom ustja oblike Consp. 20.4 (*t. 1: 12-14*) se pojavijo okoli leta 30 n. št. in so zelo pogosti v sklopih iz srede stoletja po cellem Sredozemlju (Consp. 1990, 86). Uveljavijo se kot ena vodilnih oblik poznopadske oblikovne skupine A. Na Školaricah so prisotni v enakem številu v padski sigilati B in v poznopadski sigilati. Njim podobni in sočasni so krožniki s stopničastim prehodom oblike Consp. 21.3 (*t. 1: 15*), ki so veliko redkejši v obeh proizvodnjah, zato smo večino ustij, ki bi lahko pripadala obema oblikama, pogojno uvrstili v obliko Consp. 20.4. Na zunanjem obodu roba ustja so bile v nasprotju si ležečih parih razporejene aplikacije: rozete (*t. 1: 13*), palmovi listi z girlandami in maske (npr. z dolgimi lasmi in diademom - *t. 1: 12*).

Priljubljene cilindrične čaše z ravnim dnom Consp. 29 (*t. 4: 12*) niso okrašene z aplikacijami, temveč včasih s profiliranim pasom na zunanji površini ostenja. Odlomke ustij večinoma težko ločimo od cilindričnih skodelic oblike Consp. 27 (*t. 1: 16,17*), ki so jih od avgustejskega obdobja dalje izdelovali tudi v istrskem Loronu (Maggi 2001, 131). Izdelava obeh oblik skodelic v padski sigilati B se je okvirno končala v klavdijskem času (Consp. 1990, 100, 104; Oberosler 1995, 294) oziroma z iztekom celotne proizvodnje nekoliko kasneje (glej op. 8). V poznopadski sigilati so skodelice oblike Consp. 27 redke. Najmlajše so bile najdene v grobovih trajanskega obdobja. Poznopadske skodelice oblike Consp. 29 so pogoste predvsem v zahodni Padski nižini, izdelovali so jih do sredine 2. st. (Zabehlicky-Scheffenegger 1992, 419, 423).

V tiberijskem obdobju se iz predhodnih oblik razvijejo krožniki z zaobljenim ostenjem oblike

<sup>10</sup> Omenjene raziskave v zadnjem desetletju so dokazale jasno ločitev na izdelke padskih in poznopadskih delavnic. Kljub temu večina avtorjev padsko proizvodnjo obravnava kot enotno. Pri slabo ohranjenih kosih "skupnih oblik" ju dejansko izrazito težko ločimo po makroskopskih lastnostih. Poleg tega sedanja kronologija ni ločena na posamezne proizvodnje, zato še vedno ni jasen zaključek proizvodnje padske sigilate B. Zaradi majhnega števila kosov in lažje preglednosti bomo te oblike torej obravnavali skupaj.

Consp. 4.6 (t. 2: 1) in s stopničastim prehodom oblike Consp. 6.2 (t. 2: 2,3). V padski sigilati se pojavljajo izključno brez aplik do klavdijskega obdobja. Takrat začnejo poznopadski lončarji nanje pritrjevati predvsem prostoročno izdelane dvojne spirale ter v kalupu narejene aplikacije rozet, delfinov in mask (Schindler-Kaudelka, Fastner, Gruber 2001, 129-130). Poznopadski izdelki (t. 2: 3) so dokaj redki in se sporadično pojavljajo do konca 1. st. (id. 124,143).

Prav tako so redke polkrožne skodelice na nogi Consp. 36.4 (t. 2: 4,5). Čeprav so razširjene že v tiberijskem času (padska sigilata B), njihova izdelava sega mnogo dlje (poznopadska sigilata - t. 2: 4,5), saj so na grobišču v Angeri pridane še v grobove hadrijanske in severne dobe (Lavizzari Pedrazzini 1985, 350-351).

Krožnik z visoko poševno steno in izvihanim ustjem Consp. 3 (t. 2: 7-13) je ena najbolj pogostih oblik v kontekstih druge polovice 1. st. po celem Sredozemlju, predvsem v poznoitalski proizvodnji iz srednje Italije (it. *terra sigillata tardoitalica*).<sup>11</sup> Pojavi se že na Štalenski gori in v Bolseni nekoliko pred sredino 1. stoletja, nato prevladuje v Pompejih in domicijanskih plasteh v Ostiji (Kenrick 1985, 177; Consp. 1990, 56). Datirani primerki poznopadske sigilate so najdeni v grobnih celotah od neronskega do antoninskega časa (Zabehlicky-Scheffenegger 1992, 421), kar kaže, da je njihova proizvodnja trajala še dolgo v 2. st. Na območju Norika poznopadski krožniki oblike Consp. 3 ne prevladujejo (id. 416), kar nasprotno opažamo pri poznoitalskih krožnikih oblike Consp. 3 v Sredozemlju. Na Školaricah je njihov odstotek (16,3 % za vrednosti minimalnega števila posod) med odkritimi oblikami severnoitalske sigilate izjemno visok, celo enak deležu skodelic Consp. 34 (17,4 % za vrednosti minimalnega števila posod). Med 14 odkritimi primerki jih pripada 5 padski in 9 poznopadski sigilati.

V neronskem obdobju se v poznopadski sigilati pojavijo popolnoma nove oblike krožnikov in skodelic z značilnim barbotinskim okrasom. S. Zabehlicky-Scheffenegger (1992, 416-417) jih je definirala kot oblikovno skupino B. Domneva se, da so poznopadski lončarji posnemali oblike sočasne galske sigilate, čeprav odnos med proizvodnjama še ni natančneje pojasnjen. V Padski nižini so namreč v 1. st. z galsko sigilato trgovali le v zelo skrom-

nem obsegu (Mazzeo Saracino 2000, 39). T. i. oblikovna skupina B se popolnoma uveljavi v flavijskem času, ko je njen delež v enakem razmerju s skupino A (z apliciranim okrasom), pozneje pa prevlada. Proizvodnja ali boljše uporaba izdelkov skupine B in s tem tudi celotna poznopadska proizvodnja se je končala sredi 2. st. (Zabehlicky-Scheffenegger 1992, 421-422).

Servisi krožnikov in skodelic skupine B imajo enako oblikovano ustje.<sup>12</sup> Na Školaricah so med oblikovno skupino B najštevilčnejši odlomki servisa z izvihanim ustjem - krožnika oblike Consp. 39 (t. 3: 12) in skodelice oblike Consp. 43 (t. 3: 9, 10,11), ki predstavljata glavno obliko flavijskega časa v padskem in noriško-panonskem prostoru (Consp. 1990, 120, 128; Schindler-Kaudelka, Groh 1994, 360). Med gradivom je najdena tudi varianta skodelice oblike Consp. 43.2 (t. 4: 1), ki ima na notranjem robu ustja nizek pokončen rob (Consp. 1990, 128).

Servis z obrobljenim horizontalnim robom ustja krožnika oblike Consp. 41 (t. 4: 4,5) in skodelice oblike Consp. 45 (t. 4: 2) je manj številčen, saj je značilen predvsem za zahodno Padsko nižino - Lombardijo in Ticino (Consp. 1990, 124, 132; Zabehlicky-Scheffenegger 1992, 419).

Ohranjen je še odlomek krožnika z ravnim robom ustja (t. 4: 3), ki lahko pripada krožniku z ukrivljenim profilom stene oblike Consp. 40 ali krožniku z ravnim profilom stene oblike Consp. 42, čeprav je zadnji izjemno redek (Consp. 1990, 122, 126; Schindler-Kaudelka, Groh 1994, 360).

Zaradi fragmentarnosti kosov ne moremo sklepati o uporabljeni shemi barbotinskega okrasa. Ohranjeni so le posamezni motivi: lilija (t. 3: 10), bršljanov list z vejico (t. 3: 12), grozd z vejico (t. 4: 2).

Posodje poznopadske oblikovne skupine C na Školaricah ni bilo odkrito.

Med gradivom so ohranjeni le trije žigi lončarjev, eden pripada padski sigilati B in dva poznopadska oblikovni skupini A.

Na dnu krožnika (t. 4: 11) oblike Consp. 3 (manj verjetno Consp. 4.6-7) je odtisnjen žig *in planta pedis* PHIL( ) (OCK 1438.9). Takšen žig je bil najden le še na krožniku v Concordiji (CVArr 1340), medtem ko so bili žigi z istim imenom, a drugačnih oblik najdeni tudi drugje po Sredozemlju. Ker gre verjetno za več različnih lončarjev, ki pa so izpričani s skromnim številom najdb, je natančnejše lokali-

<sup>11</sup> Mlajša proizvodnja italske sigilate v srednji Italiji, ki nasledi aretinsko sigilato in je sočasna s poznopadsko sigilato - druga polovica 1. st. in prva polovica 2. st. Za definicijo izraza in proizvodnje glej Consp. 1990, 13-16.

<sup>12</sup> Premeri ustij so med 6 in 27 cm. Umetno ločnico med skodelicami in krožniki pri 6 cm višine in 15 cm premera smo prevzeli po Schindler-Kaudelka, Groh 1995, 360.

ziranje in datiranje delavnic izredno težko. Po obliki lahko žig le okvirno datiramo po letu 15 n. št. Primerki bi lahko umestili med padsko sigilato B le pogojno, na podlagi velikosti žiga, ki je pri poznopadskih izdelkih mnogo manjši. Faktura primerka izstopa, saj se ne pojavlja na Štalenski gori. Pripadala bi lahko eni od manjših, bolj lokalnih delavnic na severnojadranski obali.<sup>13</sup>

Žigi poznopadske sigilate imajo v drobnem okvirju v obliki podplata (*in planta pedis*) vtisnjene le tri inicialke - kratice *tria nomina*. Skodelica oblike Consp. 29 (*t. 4: 12*) nosi žig *in planta pedis* C·T·P (OCK 2027). S tem žigom so v Padski nižini izdelovali krožnike oblike Consp. 20.4 in skodelice oblik Consp. 29 ter 34 vsaj med vladavino Klavdija in Domicijana (30-80 n. št.) ter mogoče še dlje. Območje razprostranjenosti teh izdelkov pokriva celotno tržišče poznopadske proizvodnje. Od najbolj zahodnih najdb v Tortoni in Locarnu (CVArr 1886), torej v Liguriji in zahodni Padski nižini, do Sirmija na vzhodu (Brukner 1981, 54, 143, t. 1: 26, t. 9: 7) ter Flavije Solve (Schindler-Kaudelka, Groh 1994, 361, t. 24: 25,26) in Petovione (CVArr 1886) na severu. Najdbe se zgoščijo na severnem Jadranu, na grobišču v Osorju (Makjanič 1985, 43, t. 3: 26), v Akvileji in Morlungu (CVArr 1886) ter v Emoni, kjer ga najdemo tudi na enaki obliki skodelice (Petru 1972, grob 1347.1, t. 117: 10).

Tretji žig (*t. 4: 10*) na dnu skodelice Consp. 34 je težko berljiv - mogoče gre za žig *in planta pedis* C... ali Q... .

Poleg gladke padske sigilate je na Školaricah prisotna tudi severnoitalska reliefna sigilata (it. *terra sigillata norditalica decorata*) in sicer izključno z dvoročajnimi skodelicami Sarius. Predstavlja pa le 9,7 % deleža sigilatnega posodja ali 14 % deleža celotne padske proizvodnje (*tab. 1* - vrednosti ocene minimalnega števila posod). Njena proizvodnja se začne že v zadnji četrtini 1. st. pr. n. št., je najbolj množična v prvih treh desetletjih 1. st. n. št. in se zaključi v klavdijskem obdobju (Schindler-Kaudelka 1980, 66; ead. 1998, 292; ead. 2000, 62). Zanesljivo so ugotovljene delavnice v Ravenni, Faenzi in Cremoni, vendar niso bile edine, saj mnogo kazalcev kaže na številne delavnice, podobno kakor tudi pri drugih padskih proizvodnjah (Schindler-Kaudelka 2000, 54). Območje trgovanja s severnoitalsko reliefno sigilato se prekriva z razprostranjenostjo gladke padske sigilate (Kenrick 2000, 47-50).

Zaradi močne fragmentiranosti in odsotnosti žigov odlomke, odkrite na Školaricah, težko ločimo na ožje podskupine ali posamezne delavnice. Posamezni motivi okrasa se pojavljajo v najrazličnejših kombinacijah, zato so odkriti odlomki premajhni, da bi lahko rekonstruirali shemo okrasa, po kateri ločimo skupine izdelovalcev. Med rastlinskim okrasom zasledimo palmete (*t. 5: 9,11*) in akantove liste (*t. 5: 2,6,8,10*), včasih z rozeto ali pentljo (*t. 5: 6,8,10*). Niz reliefnih krogcev obroblja okrasno polje na odlomku (*t. 5: 12*). Le za odlomek *t. 5: 11* lahko predpostavljamo, da je bilo okrasno polje z linijami razdeljeno na trikotne odseke ali mrežo v obliki zvezde, medtem ko na najbolj ohranjeni skodelici *t. 5: 1* stilizirani steber deli okrasno polje na pravokotne odseke. Vmesni prostor zapolnjujeta večji kantaros ter stilizirana upodobitev vojščaka, predstavljena s čelado s perjanico in okroglim ščitom. Slaba kvaliteta fakture in izdelave okrasa pri večini primerkov kaže na najmlajšo fazo proizvodnje (Brusić 1999, 28; Schindler-Kaudelka 2000, 53-54).

## VZHODNA SIGILATA

Opazen del sigilatnega posodja predstavljajo odlomki vzhodne sigilate B, in sicer njene kasnejše proizvodne faze B2, za katero je značilna prozorna glina z veliko sljude in nebleščečim, milnatim premazom oranžne barve (Hayes 1985, 51). Na osnovi močne prisotnosti vzhodne sigilate B1 in B2<sup>14</sup> v Efezu in Prienu je bil predpostavljen njen izvor v zahodnem delu Male Azije (Hayes 1985, 49), kar so potrdile tudi kemične in mineraloške raziskave. Enako vsebnost težkih mineralov imajo namreč le gline v okolici antičnega Trallesa (dan. Aydin), 50 km od obale (Schneider 2000b, 532). Pomembnost lončarskih delavnic v tem mestu kažejo tudi omembe Plinija starejšega (Hayes 1985, 49).

Vzhodna sigilata B1 je pod močnim vplivom italske sigilate, kar je opazno v oblikah in pri žigih z imeni proizvajalcev. Datirana je v obdobje od začetka do tretje četrtine 1. st. n. št. in je razširjena predvsem v egejskem bazenu. Že v prehodni fazi B1/2 (v tretji četrtini 1. stoletja) se razvijejo značilne oblike kasnejše vzhodne sigilate B2, ki se odmaknejo od italskih vzorov. Izdelava se omeji na nekaj standardnih oblik, velikost posod se s časom povečuje, žige lončarjev zamenjajo stilizirani žigi rozet in palmet. Čeprav je kakovost posodja občutno slabša, saj je keramika mehkejša in premazana z debelej-

<sup>13</sup> Ustno mnenje S. Zabehlicky-Scheffenegger po ogledu odlomka.

<sup>14</sup> Za definicijo vzhodne sigilate B1 in B2 glej Hayes 1985.



šim premazom, se njena razširjenost močno poveča (Hayes 1985, 49-52).

Na Jadranu so primerki vzhodne sigilate B1 sporiadični, medtem ko je prisotnost vzhodne sigilate B2 dokumentirana z velikim številom na kopenskih in podvodnih najdiščih (Jurišić 2000, 33-34).

Izredno izpoveden je tovor na potopljeni ladji z rta Izmetišče na Paklenih otocih v osrednji Dalmaciji. Trgovska ladja iz prve polovice 2. st. je prevažala mešan tovor: devet večjih kamnitih polizdelkov iz apnenca in enega iz zelenega granita, nekaj grških amfor Dr. 2-4 s Kosa ter večjo količino (nad 3000 odkritih primerkov) posodja - vzhodne sigilate B2 in vzhodne kuhinjske keramike (Jurišić 2000, 65). Ladja je plula po glavni pomorski poti ob vzhodni jadranski obali iz Grčije ali Male Azije v smeri proti pomembnim pristaniščem severnega Jadrana - Akvileji in Ravenni ali drugim večjim istrskim in dalmatinskim mestom.

Med sigilatnim gradivom iz 1. in 2. st. na Školaricah zavzema vzhodna sigilata B2 ok. 25-odstotni delež (*tab. 1*). Najbolje so zastopani odlomki bikoničnega krožnika z ravnim dnom oblike Hayes 60 (*t. 6: 1-5*) in odlomki skodelice oblike Hayes 80 (*t. 6: 6-10*). Krožnike Hayes 60 so izdelovali že v prehodni fazi B1/2 v času 50/60-80/90 n. št. Sčasoma so se iz manjših primerkov z izrazitim trikotnim in nizkim robom razvili veliki krožniki s poenostavljenim robom in značilnim profilom roba ustja v obliki kladiva (Hayes 1985, 64). Ta vodilna oblika vzhodne sigilate B2 je zelo pogosta na jadranski obali in drugod po vzhodnem Sredozemlju. Na brodolomu Izmetišče so bili krožniki Hayes 60 odkriti v originalni legi, ki kaže na način, kako je bilo posodje na ladji zloženo in natovorjeno. Krožniki so bili namreč zloženi v nizih, tako da so bili v večje postavljene vedno manjši primerki. V enem primeru je bila v krožnik oblike Hayes 60 postavljena skodelica oblike Hayes 80, s katero bi lahko tvoril servis (Jurišić 2000, 32-33). Izdelava tovrstnih skodelic se je začela po uničenju Pompejev - ok. l. 80 (Hayes 1985, 69).

Med obravnavanim materialom na Školaricah so prisotni le mlajši primerki krožnikov Hayes 60, ki so sočasni s skodelico Hayes 80. V Efezu so jih uporabljali še celo drugo polovico 2. in prvo polovico 3. stoletja (Gassner 1997, 127).

Krožniki z izvihanim in nato nazaj zavitim ustjem oblike Hayes 62 (*t. 7: 1,2*) tvorijo servis s skodelico z enakim profilom ustja oblike Hayes 74 (*t. 7: 3-7*). Po stiliziranih žigih v obliki rozet in palmet sta obliki datirani predvsem v flavijsko in trajansko obdobje - 70/75-120. Različici krožnika oblike Hayes 62B (*t. 7: 2*) in skodelice oblike Hayes

74B (ni prisotna na Školaricah), za kateri je značilna s koleščkanjem okrašena zunanja površina roba ustja, sta dokaj redki (Hayes 1985, 65, 68).

Servis z izvihanim ustjem krožnika oblike Hayes 63 (*t. 7: 9*) in skodelice oblike Hayes 75 (*t. 7: 8*) je sočasen. Ker je po izdelavi, obliki in žigih zelo podoben servisu, ki ga sestavljata krožnik oblike Hayes 62 in skodelica oblike Hayes 74, jih je Jurišić celo združil v skupne oblike 62/63 in 74/75. Kot varianto A je določil enostavnejši profil izvihanega ustja (po Hayesu obliki 63 in 75) ter kot B zapletenejši profil Hayesovih oblik 62 in 74 (Jurišić 2000, 33).

Med materialom s Školaric je prisotna tudi skodelica z rahlo izvihanim ustjem oblike Hayes 76, tako njena manjša in starejša varianta A (*t. 7: 10,11*), ki je značilna predvsem za vmesno fazo B1/2 in zgodnje obdobje faze B2, kakor večja in mlajša varianta B (*t. 7: 12,13*), ki je bila odkrita tudi med tovorom ladje na Izmetišču (Jurišić 2000, 32). V Sredozemlju so najbolj pogoste prav največje in najbolj pozne variante teh skodel (Hayes 1985, 68-69).

Odlomek dna *t. 7: 15* verjetno pripada širšemu krožniku Hayes 77, ki se kot redka oblika pojavlja v prvi polovici 2. st. (Hayes 1985, 69).

Žigi v obliki rozet ali palmet se na dnu skodelic ali krožnikov pojavljajo v flavijsko-trajanskem obdobju (Hayes 1985, 52). Na dnu skodelice oblike Hayes 76B (*t. 7: 13*) je vtisnjena palmeta, na dnu skodelice oblike Hayes 71 ali manjšega krožnika oblike Hayes 60 (*t. 7: 14*) pa rozeta. V drugi četrtini 2. stoletja posodja iz proizvodnje vzhodne sigilate B2 niso več žigosali.

Na Školaricah je najštevilčneje zastopan krožnik oblike Hayes 60, sledijo mu skodelice oblike Hayes 80, skodelica oblike Hayes 76, servisi oblik Hayes 62 in 74 ter Hayes 63 in 75. Ostale oblike se pojavljajo sporiadično. Torej je prisoten cel razpon oblik posodja, poznanega s tovara na Izmetišču, ki lepo predstavlja uvoz vzhodne sigilate B2 na Jadran.

Vzhodno sigilato B najdemo v velikih jadranskih pristaniščih v Saloni (Jurišić 2000, 34), Naroni (Topić 2003, 192), Ravenni (Maioli 1990, 422) in Akvileji (Ventura 1991; ead. 1994; Mandruzzato, Tiussi, Degrassi 2000, 361), v istrskih mestih Pola (Matijašič 1991; Maggi, Starac 2000) in Tergeste (Maselli Scotti 1987) in najdiščih v notranjosti do Emone (Petru 1972, 70, grob 778, t. 50: 30). Mnogi primerki so bili najdeni v Kvarnerju (Makjanić 1983, 52). Na grobišču v Bakru najdemo vzhodno sigilato B v grobovih od neronskega do antoninskega obdobja, v najmlajšem grobnem kontekstu skupaj z novcem Faustine starejše (Makjanić 1983, 52).

Vzhodna sigilata je bila najdena tudi v vilah v

Istri: v Loronu (Maggi, Starac 2000; Maggi 2001, 152-153) in na Brionih (Maggi, Starac 2000; Vidrih Perko, Pavletić 2000, 263-264). Mlajši krožnik Hayes 60 je bil najden tudi pri izkopavanjih vile v Simonovem zalivu (Mikl Curk 1996, 252, sl. 8), v bližnjem Štramarju (Maselli Scotti 1997, 70, t. 10: 23) in vili Joannis v akvilejskem agru (Strazzula Rusconi 1979, 42).

Množični izvoz iz Male Azije naj bi bil na jadranskem prostoru omejen s sredino 2. stoletja. Novejše raziskave so pokazale, da se proizvodnja vzhodne sigilate B ni prenehala sredi 2. st., kakor je domneval Hayes (1985, 51), temveč je ta v Efezu in drugih mestih na južnem delu zahodne obale Male Azije prisotna tudi v kasnejših plasteh do prve polovice 3. stoletja (Gassner 1997, 127). V Korintu dominira med fino keramiko še celotno 2. st. (Slane 2000, 307). Čeprav mogoče v manjšem številu, jo moramo v tem obdobju pričakovati tudi na jadranski obali, predvsem krožnike Hayes 60 (Vidrih Perko, Pavletić 2000, 264), saj se uvoz afriške sigilate razmahne šele nekoliko kasneje (Pröttel 1996; Biondani 1992).

## SKLEP

Obravnavano sigilatno gradivo nam po eni strani prikazuje jedilne navade prebivalcev vile v Školaricah v 1. in 2. st., ki so bile popolnoma vpete v italški način življenja in prehranjevanja. Po drugi strani je izredno pomembno za datiranje nastanka vile in dopolnjuje naše vedenje o trgovini s keramiko na severnem Jadranu v 1. in 2. st.

Fragmentarnost in razpršenost sigilate sicer ne dopuščata natančnejšega datiranja izgradnje kompleksa brez analize celotnega odkritega korpusa. Kljub temu lahko poskusimo postaviti nekatere preliminarne domneve.

Po predloženih dokazih lahko nastanek datiramo nekje v drugo četrtino ali sredino 1. st. n. št., na kar kažejo maloštevilni odlomki aretinske in severnoitalske reliefne sigilate, katerih izdelava se izteče nekako v sredini stoletja. Pomenljiva je tudi odsotnost keramike s črnim premazom in le minimalna prisotnost sive venetske keramike, ki se na severnem Jadranu sporadično pojavljata še v prvi polovici stoletja (Stokin 1990; Buora 2001; Merlatti 2003, 7). Čeprav so nekatere najdene oblike aretinske (Consp. 22.1 - t. I: 1) in padske sigilate (Consp. 22.6 - t. I: 9, delno Consp. 18.2 - t. I: 7,8) časovno zamejene

s prvo četrtino 1. stoletja, je njihovo število preskromno, da bi lahko izgradnjo vile pomaknili v čas njihove izdelave. Raje zanje domnevamo rezidualnost<sup>15</sup> ali dolgotrajnejšo uporabo, kar velja tudi za redke sočasne novčne najdbe - npr. as iz obdobja Tiberijeve vladavine (15-16 n. št.).<sup>16</sup>

V zgodnjem obdobju vile je med sigilatnim gradivom (*tab. 1*) dobro razvidna skoraj popolna prevlada močne padske lončarske produkcije, ki ji moramo prišteti tudi manjši delež domnevnih delavnic lokalno-regionalnega značaja. Aretinskih izdelkov je le za vzorec, kar je značilno za celotno severnojadransko območje. Pri primerjavi deleža aretinskih in padskih žigov je Makjaničeva (1989, 61) pokazala, da je na območju *Regio X* in Kvarnerja delež padskih proizvajalcev celo šestkrat do sedemkrat večji od aretinskih, medtem ko so v Panoniji njihova razmerja skorajda izenačena. Posredniško vlogo Akvileje kot glavnega distribucijskega centra za trgovino s Panonijo lahko vidimo tudi v šibki premoči padske sigilate nad aretinsko v tem mestu (*ead.* 61). Prebivalci naselbin na severnem Jadranu so aretinsko sigilato pridobivali preko Akvileje ali preko neposredne povezave med zahodno jadransko obalo - Rimini, Adria in Ravenna - z obalnimi istrskimi mesti (Maggi 2001, 149, 158).

Tudi visok odstotek severnoitalske reliefne sigilate potrjuje, da moramo začetek vile postaviti že v prvo polovico 1. st. oziroma vsaj v klavdijsko obdobje.

Ne preseneča, da so med odlomki severnoitalske proizvodnje najpogosteje zastopani izdelki poznopadske sigilate, saj se obdobje njene izdelave, za razliko od padske sigilate, v celoti vključuje v čas življenja vile. Proizvodnja padske sigilate pa se verjetno ne konča v klavdijskem obdobju, temveč nekoliko kasneje. Najštevilnejše oblike italške sigilate na Školaricah predstavljajo "skupne" oblike padske in poznopadske proizvodnje (oblikovna skupina A), ki na drugih najdiščih prevladujejo predvsem v kontekstih sredine 1. st. Na mizah se jim v neronskem in flavijskem obdobju pridružijo popolnoma nove oblike - poznopadski servisi oblikovne skupine B.

V zadnji četrtini 1. stoletja se prične uvoz vzhodne sigilate B2 iz daljnih krajev zahodne Male Azije. Ta ima na našem najdišču presenetljivo visok delež (ok. 25 %), še posebej če upoštevamo le sigilato iz 1. in 2. st. Ker je za večino oblik poznopadske sigilate značilna velika homogenost med celotnim časovnim razponom izdelave, žal ne moremo pri-

<sup>15</sup> Možna bi bila začetna faza poselitve pred izgradnjo kompleksa, ki je stratigrafsko slabo ohranjena (Trenz et al. 2002).

<sup>16</sup> Novčne najdbe so bile določene v Numizmatičnem kabinetu Narodnega muzeja Slovenije.

merjati, kako so se razmerja med poznopadske sigilato in vzhodno sigilato spreminjala. Pri primerjavi deležev oblikovne skupine A in B poznopadske proizvodnje opazimo nižji delež skupine B. To lahko razložimo le z domnevo, da se je v prvi polovici 2. st., ko drugje oblikovna skupina B poznopadske sigilate nadvlada oblikovno skupino A (Zabehlicky-Scheffenegger 1992, 421-422; Schindler-Kaudelka, Fastner, Gruber 2001, 153), vzhodna sigilata B2 močno usidrala na mizah prebivalcev vile na Školaricah.

Čeprav se vzhodna sigilata B2 pojavlja na mnogih jadranskih najdiščih, pa lahko podatke s Školaric primerjamo le z redkimi. Na kvarnerskih najdiščih (Reka, Omišalj, Krk in Osor) predstavlja delež vzhodne sigilate B1 in B2 okoli 14 % sigilatnega gradiva. Izstopa nekropola v Bakru, kjer se delež vzhodne sigilate dvigne na zavidljivih 52,17 % (Makjanić 1983, 51-52).<sup>17</sup> Visok odstotek vzhodne sigilate lahko zasledimo tudi v Kastrumu na Brionih, kjer je količina vzhodne sigilate le za tretjino manjša od količine celotne italske sigilate (Vidrih Perko, Pavletić 2000, 267, fig. 1).<sup>18</sup> Presenetljiv je delež v vili v Loronu, kjer vzhodna sigilata obsega le 4 % sigilatnega gradiva. Zelo verjetno gre za kronološke nianse, saj so predstavljeni stratigrafski konteksti iz 1. in začetka 2. st., obdobja največjega razcveta italskih in padskih delavnic, h katerim prištevamo tudi lokalno delavnico v Loronu (Maggi, Starac 2000, 356; Maggi 2001, 152). Torej so te plasti relativno starejše od razcveta uvoza vzhodne sigilate na severnem Jadranu. K drugačni sliki verjetno pripomore dejstvo, da gre za predel vile z gospodarsko funkcijo, saj se tudi na Školaricah kaj malo sigilate pojavlja na delu, za katerega domnevamo gospodarski značaj.

Na Brionih in Loronu opazimo le nezaten delež poznopadske oblikovne skupine B (Maggi 2001, 147; Vidrih Perko, Pavletić 2000, 263). Na najdiščih Osor, Krk, Omišalj, Reka in Bakar v Kvarnerju pa je popolnoma odsotna (Makjanić 1987, 231). To potrjuje domneve o prevladi vzhodne sigilate B2 v prvi polovici 2. st. na vzhodni obali severnega Jadrana, ki se je razširila na račun poznopadske sigilate oz. njene oblikovne skupine B.

Zelo visok, 60-70 %, delež vzhodne sigilate<sup>19</sup> je bil najden tudi v Tergestu pri izkopavanjih za rimskim

gledališčem, kar je F. Maselli Scotti (1987, 217-220) navedlo na domnevo, da bi lahko promet z Vzhodom (odraz katerega bi bila močna prisotnost vzhodne sigilate) lahko potekal neposredno iz Trsta, mimo glavnega pristanišča regije - Akvileje. To naj bi potrjevala tudi skromna prisotnost vzhodne sigilate v Akvileji (ead. 219). Čeprav so na vzhodnem delu akvilejskega foruma dejansko izkopali le skromen delež vzhodne sigilate (Ventura 1991; ead. 1994), menim, da trenutno Akvileje ne moremo izključiti kot glavnega trgovskega centra za vzhodno sigilato. Šele v zadnjem času se v ogromnih akvilejskih muzejskih depojih<sup>20</sup> odkriva gradivo, uvoženo iz egejskega in vzhodnomediterranskega prostora (amfore, oljenke, egejska kuhinjska keramika) od 1. st. n. št. dalje (Mandrúzato, Tiussi, Degrassi 2000). Vzhodna sigilata je bila, kakor vse vrste keramike, blago sekundarnega pomena. Ladje so z vzhodnega Sredozemlja na severni Jadran pripeljale predvsem cenjeno egejsko vino, ki so ga prevažali v egejskih variantah amfor Dr. 2-4, v rodoških cesarskodobnih amforah in kretskih amforah (Jurišić 2000, 58).

Uvoz vzhodne sigilate B2 najverjetneje postopoma pojenja v drugi polovici 2. st. Konec 2. stoletja se pogled na pogrinjke popolnoma spremeni s prihodom afriške sigilate, ki prevlada v poznoantičnem obdobju (Pröttel 1996; Biondani 1992).

Glavno trgovsko središče za severnojadransko območje je bila Akvileja (Tassaux 2004), kamor so blago iz vzhodnega Sredozemlja pripeljale velike čezmorske ladje. Del prometa je lahko potekal neposredno tudi preko pristanišča v Tergestu. Iz obeh mest, predvsem pa iz Akvileje, je blago nato po kopenskih poteh odšlo proti alpskemu in podonavskemu prostoru, po rečnih poteh v Padsko nižino, po morju pa so ga nato z manjšimi plovili razprodali v druga severnojadranska oz. istrska mesta, naselja in vile, ki so velikokrat predstavljale manjša distribucijska središča za okolico.

## KATALOG

V katalogu so predstavljene reprezentativne najdbe za vse ugotovljene oblike. Opisu najdbe in določitvi oblike sledijo faktura, stopnja ohranjenosti ter oznaka in okoliščine najdbe. Fakture so bile določene po makroskopskih lastnostih keramike. Barve

<sup>17</sup> V Osorju in Bakru izvirajo podatki iz nekropole 1. in 2. stoletja, za druge časovni obseg gradiva ni znan (Makjanić 1983; ead. 1985).

<sup>18</sup> Čeprav so na omenjenem grafu vrednosti podane za celotno keramično gradivo najdišča, smo primerjali le podatke za italsko (v tekstu je omenjena le padska proizvodnja: padska sigilata, čaše Sarius, kozarci Aco in poznopadska sigilata) in vzhodno sigilato (šteta naj bi bila le vzhodna sigilata B).

<sup>19</sup> Sem so vštet tudi maloštevilni primerki vzhodne sigilate A in fokajske sigilate.

<sup>20</sup> Za navedbe o velikih količinah vzhodne sigilate v akvilejskih depojih glej Strazzula Rusconi 1979, 42.

so bile določene z *Munsell Soil Color Charts*, 1992. Za opise drugih lastnosti gline, primesi in premaza smo uporabili priročnik Horvat 1999.

Okrajšave: odl. = odlomek, ppd = *planta pedis dextrorsum*, OHU = ohranjenost ustja, OHD = ohranjenost dna, PN KER = posebna najdba - keramika, SE = stratigrafska enota, kv. = kvadrant.

Med gradivom s Školaric smo prepoznali naslednje fature:

*Aretinska sigilata A* (it. *sigillata Aretina A*): Zelo fino zrnata prečiščena glina brez primesi. Oksidacijsko žgana. Trda ali mehka. Barva preloma svetlo rdečkasto rjava (2.5YR 7/4), svetlo rdeča (2.5YR 7/6), roza (5YR 7/4) ali rdečkasto rumena (5YR 7/6). Premaz je zelo trd, gladek, (svilnato) bleščeč in zelo dobro ohranjen. Močno se drži podlage. Prekriva celo posodo in je enakomerne rdeče barve (2.5YR 4/8).

*Padaska sigilata B* (it. *sigillata Padana B*): Zelo fino zrnata prečiščena glina brez primesi ali redkimi primesmi fine sljude. Oksidacijsko žgana. Mehka, mazava, porozna, lahko zelo prašna keramika. Barva preloma je rdečkasto rumena (5YR 7/8, 5YR 7/6). Premaz je zelo trd. Od kvalitetnega s svilnatim leskom do slabšega nebleščečega, lisastega in grobega premaza. Večinoma se lušči. Prekriva celo posodo. Premaz je temnordeč (2.5YR 3/6), rdeč (2.5YR 4/6) ali rdečerjav (2.5YR 4/4).

*Poznopadska sigilata* (it. *sigillata Tardopadana*): Gre za več faktur. Večinoma zelo fino zrnata prečiščena glina z redkimi ali zmernimi primesmi: zelo fina in fina zrnca sljude, lahko redka fina bela in črna zrnca. Oksidacijsko žgana. Mehka, redkeje trda. Lahko mazava, rahlo porozna keramika. Barva preloma je rdečkasto rumena (5YR 7/6) ali roza (7.5YR 8/4 in 5YR 8/4). Premaz dobro, srednje ali slabo ohranjen, gladek z nepravilnostmi, trd, rahlo svetleč do nebleščeč in enakomerne ali nenakomerne rdeče barve (2.5YR 4/8 do 5/8, 10R 5/8, 10R 4/6-8).

*Severnoitalijska reliefna sigilata Sarius* (it. *sigillata norditalica decorata di tipo Sarius*): Zelo fino zrnata prečiščena glina brez primesi ali z redkimi zrnca fine in zelo fine sljude, redko tudi z drobnimi temnimi in belimi zrnca. Oksidacijsko žgana. Mehka, mazava in prašna, rahlo porozna keramika. Barva preloma je rdečkasto rumena (5YR 6/6-8, 5YR 7/8) ali svetlo rdeča (2.5YR 6/6). Premaz je srednje ali slabo ohranjen oziroma ni ohranjen. Lušči se v luskah. Je debel, na ZP gladek in bleščeč, na NP nebleščeč z rahlimi nepravilnostmi (linije vretena). Barva premaza je rdeča (10R 4/8 do 5/8).

*Vzhodna sigilata B2*: Zelo fino zrnata prečiščena glina z obilnimi zelo finimi, finimi in drobnimi zrnca sljude. Oksidacijsko žgana. Mehka, porozna, prašna keramika. Barva preloma je rdečkasto rumena (5YR 6/6, 5YR 7/6-8). Premaz je nebleščeč, milnat in se zelo rad lušči. Enakomerne oranžne oz. rdeče barve (2.5YR 5/8, 6/8).

Tabla 1

*Aretinska sigilata*

1. Odl. ustja in ostenja skodelice oblike Consp. 22.1; aretinska sigilata A; OHU 2 %; PN KER 0864; SE 101; kv. 27/C3.
2. Odl. ustja in ostenja skodelice oblike Consp. 26.2.1; aretinska sigilata A; OHU 12 %; PN KER 0804; SE 220; kv. 08/C2.
3. Odl. ustja krožnika oblike Consp. 6.2 (domnevno); aretinska sigilata A; OHU 5 %; PN KER 1901; SE 260.B; kv. 08/B3.
4. Odl. dna krožnika (oblike Consp. 3, 4 ali 18-21) s peresnim okrasom na notranji površini dna; aretinska sigilata A; PN KER 1124; SE 1; kv. 27/A3.
5. Odl. ustja krožnika oblike Consp. 20.4; aretinska sigilata A; aplikacija palmovega lista in girlande; OHU 5 %; PN KER 2142; SE 240; kv. 8/B2.
6. Odl. ustja krožnika oblike Consp. 20.4; aretinska sigilata A; OHU 5 %; PN KER 0533; SE 101; kv. 27/B3.

*Padaska in poznopadska sigilata*

7. Odl. ustja in ostenja krožnika oblike Consp. 18.2; padaska sigilata B; OHU 10 %; PN KER 1273; SE 266; kv. 08/B2.
8. Odl. ustja in ostenja krožnika oblike Consp. 18.2; padaska sigilata B; OHU 2 %; PN KER 1568; SE 389; kv. 12/E2.
9. Odl. ustja skodelice oblike Consp. 22.6; padaska sigilata B; OHU 5 %; PN KER 0760; SE 303; kv. 13/A2.
10. Odl. ustja in ostenja skodelice oblike Consp. 24.3; padaska sigilata B; OHU 12 %; PN KER 0082; SE 345.A; kv. 11/D1.
11. Odl. ustja in ostenja skodelice oblike Consp. 24.3; padaska sigilata B; OHU 15 %; PN KER 0814; SE 245; kv. 08/D3.
12. Odl. ostenja krožnika oblike Consp. 20.4; poznopadska sigilata; aplikacija maske z dolgimi lasmi, s spodnjo linijo in verjetno z diademom; PN KER 2932; SE 240; kv. 08/A3.
13. Odl. ustja krožnika oblike Consp. 20.4; poznopadska sigilata; aplikacija osemlistne rozete s prašniki; prežgano v ognju; OHU 5 %; PN KER 0104; SE 102; kv. 26/D2.
14. Odl. ustja in ostenja krožnika oblike Consp. 20.4; padaska sigilata B; OHU 5 %; PN KER 3002; SE 281; kv. 08/B3.
15. Odl. ostenja krožnika Consp. 21.3; Padaska sigilata B; PN KER 1790; SE 209; kv. 08/A3.
16. Odl. ustja in ostenja skodelice oblike Consp. 27.1; padaska sigilata B; OHU 5 %; PN KER 1626; SE 101; kv. 26/C4.
17. Odl. ustja in ostenja skodelice oblike Consp. 27 ali 29; padaska sigilata B; OHU 5 %; PN KER 2933; SE 276; kv. 07/D2.

Tabla 2

*Padaska in poznopadska sigilata*

1. Odl. ustja in ostenja krožnika oblike Consp. 4.6; padaska sigilata B; OHU 10 %; PN KER 2200; SE 426; kv. 12/E2.
2. Odl. ustja in ostenja krožnika oblike Consp. 6.2; padaska sigilata B; grafit na ZP ostenja; OHU 5 %; PN KER 2937; SE 240; kv. 08/C3.
3. Odl. ustja in ostenja krožnika oblike Consp. 6.2 (ali 4.6); poznopadska sigilata; OHU 5 %; PN KER 1272; SE 266; kv. 08/B2.
4. Odl. ustja skodelice oblike Consp. 36 (domnevno); poznopadska sigilata; aplikacija dvojne spirale; OHU 5 %; PN KER 2941; SE 543; kv. 27/C4.
5. Odl. ustja skodelice oblike Consp. 36 (domnevno); poznopadska sigilata; OHU 2 %; PN KER 3242; SE 101; kv. 23/E4.
6. Odl. dna krožnika s prstanasto nogo oblike Consp. 3.1 ali 4.6-7; padaska sigilata B; PN KER 2934; SE 240.A; kv. 08/C3.
7. Odl. ustja in ostenja krožnika oblike Consp. 3.2; padaska sigilata B; OHU 10 %; PN KER 1013; SE 263; kv. 08/C3.
8. Odl. ustja in ostenja krožnika oblike Consp. 3.2; poznopadska sigilata; OHU 5 %; PN KER 1842; SE 240; kv. 08/B3.
9. Odl. ustja in ostenja krožnika oblike Consp. 3; padaska sigilata B; OHU 5 %; PN KER 3059; SE 596.D; kv. 27/C4.
10. Odl. ustja in ostenja krožnika oblike Consp. 3; poznopadska sigilata; OHU 10 %; PN KER 3216; SE 297.B; kv. 08/C3.
11. Odl. ustja in ostenja krožnika oblike Consp. 3; poznopadska sigilata; OHU 5 %; PN KER 2078; SE 281; kv. 08/B3.
12. Odl. ustja in ostenja krožnika oblike Consp. 3; poznopadska sigilata; OHU 5 %; PN KER 2376; SE 240; 07/E3.
13. Odl. ustja in ostenja krožnika oblike Consp. 3; poznopadska sigilata; OHU 5 %; PN KER 1134; SE 240; kv. kv. 08/B3.
14. Odl. prstanastega dna krožnika oblike Consp. B 2.4-5; padaska sigilata B; OHD 15 %; PN KER 1296; SE 237.B; kv. 08/A4.
15. Odl. prstanastega dna in ostenja krožnika oblike Consp. B 2.7; padaska sigilata B; OHD 15 %; PN KER 1225; SE 101; kv. 27/B3.

Tabla 3

*Padška in poznopadška sigilata*

1. Odl. ustja in ostenja skodelice z rebrom oblike Consp. 34; poznopadška sigilata; ohranjeni dve apliki: maska z dolgimi lasmi in verjetno z diademom, mala maska s kratkimi lasmi; OHU 5 %; PN KER 0693; SE 159; kv. 26/C3.

2. Odl. ustja in ostenja skodelice z rebrom oblike Consp. 34; padška sigilata B; OHU 5 %; PN KER 1482; SE 311.A; kv. 12/E3.

3. Odl. ustja in ostenja skodelice z rebrom oblike Consp. 34; poznopadška sigilata; OHU 10 %; PN KER 0758; SE 202; kv. 08/D3.

4. Odl. ustja in ostenja skodelice z rebrom oblike Consp. 34; poznopadška sigilata; OHU 10 %; PN KER 2931; SE 201; kv. 24/E2.

5. Odl. ustja in ostenja skodelice z rebrom oblike Consp. 34; poznopadška sigilata; OHU 15 %; PN KER 2138; SE 240; kv. 08/B2.

6. Odl. ustja in ostenja skodelice z rebrom oblike Consp. 34; poznopadška sigilata; OHU 5 %; PN KER 2284; SE 281; kv. 08/B3.

7. Odl. prstanastega dna skodelice oblike Consp. B 3.13 (verjetno Consp. 34); poznopadška sigilata; OHD 30 %; PN KER 0998; SE 118; kv. 26/D2.

8. Odl. prstanastega dna skodelice oblike Consp. B 3.19 (Consp. 34); poznopadška sigilata; OHD 100 %; PN KER 2295; SE 543; kv. 27/C4.

9. Odl. ustja skodelice oblike Consp. 43.1; poznopadška sigilata; OHU 10 %; PN KER 1003; SE 118; kv. 26/D2.

10. Odl. ustja in ostenja skodelice oblike Consp. 43.1; poznopadška sigilata; lilija v barbotinski tehniki; OHU 20 %; PN KER 2353; SE 240; kv. 08/B3.

11. Odl. ustja skodelice oblike Consp. 43.1; poznopadška sigilata; OHU 10 %; PN KER 1708; SE 240; kv. 08/C3.

12. Odl. ustja krožnika oblike Consp. 39.1; poznopadška sigilata; bršljanov list v barbotinski tehniki; OHU 10 %; PN KER 1033; SE 118; kv. 26/C3.

Tabla 4

*Padška in poznopadška sigilata*

1. Odl. ustja skodelice oblike Consp. 45; poznopadška sigilata; grozd z vodnim listom v barbotinski tehniki; OHU 35 %; PN KER 1001; SE 118; kv. 26/D2.

2. Odl. ustja krožnika oblike Consp. 40 ali 42; poznopadška sigilata; OHU 5 %; PN KER 1336; SE 101; kv. 27/B2.

3. Odl. ustja in ostenja skodelice oblike Consp. 43.2; poznopadška sigilata; OHU 10 %; PN KER 2107; SE 240; kv. 08/C3.

4. Odl. ustja krožnika oblike Consp. 41; poznopadška sigilata; OHU 5 %; PN KER 0585; SE 118; kv. 26/C4.

5. Odl. ustja krožnika oblike Consp. 41; poznopadška sigilata; OHU 5 %; PN KER 1000; SE 118; kv. 26/D2.

6. Odl. dna in ostenja krožnika oblike Consp. 39-41; poznopadška sigilata; OHD 25 %; PN KER 1213; SE 202; kv. 08/F3.

7. Odl. prstanastega dna skodele oblike Consp. B 3.16; poznopadška sigilata; OHD 15 %; PN KER 2936; SE 240.A; kv. 08/C2.

8. Odl. dna in ostenja krožnika oblike Consp. 39-42; poznopadška sigilata; OHD 20 %; PN KER 1002; SE 118; kv. 26/D2.

9. Odl. dna in prstanaste noge krožnika oblike Consp. B 3.14 (Consp. 43-45); poznopadška sigilata; OHD 15 %; PN KER 1957; SE 543; kv. 27/C4.

10. Odl. prstanastega dna skodelice oblike Consp. B 3.18 (verjetno Consp. 34); poznopadška sigilata; žig ppd C... ali Q...; OHD 55 %; PN KER 1194; SE 247.B; kv. 08/B2.

11. Odl. prstanastega dna krožnika oblike Consp. 3 ali 4.6-7; padška sigilata; žig ppd PHIL( ); OHD 75 %; PN KER 0684;

SE 240; kv. 08/B3.

12. Odl. prstanastega dna skodelice oblike Consp. 29; poznopadška sigilata; žig ppd C-T-P; antična grafit na zunanji površini dna "A?"; OHD 15 %; PN KER 0532; SE 101; kv. 27/A3.

Tabla 5

*Reliefna severnoitalska sigilata*

1. Odl. ostenja skodelice Sarius; severnoitalska reliefna sigilata; reliefni okras na trupu: kantaros, čelada s perjanico, okrogli ščit, stiliziran steber s kapitelom v obliki peruti; PN KER 1274; SE 266; kv. 08/B2.

2. Odl. ustja in ostenja skodelice Sarius; severnoitalska reliefna sigilata; niz akantovih listov v reliefu; OHU 5 %; PN KER 0764; SE 201; kv. 08/F5

3. Odl. ustja in ostenja skodelice Sarius s trakastim ročajem, na kateremu je prečna letvica; severnoitalska reliefna sigilata; OHU 5 %; PN KER 1718; SE 406; kv. 12/A3

4. Odl. ustja in ostenja skodelice Sarius; severnoitalska reliefna sigilata; OHU 5 %; PN KER 3248; SE 245; kv. 08/C3

5. Odl. ustja in ostenja skodelice Sarius; severnoitalska reliefna sigilata; OHU 5 %; PN KER 1628; SE 101; kv. 26/C4

6. Odl. ostenja skodelice Sarius; severnoitalska reliefna sigilata; akantovi listi nad rozeto v reliefu; PN KER 1770; SE 406; kv. 12/A3

7. Odl. ustja skodelice Sarius; severnoitalska reliefna sigilata; OHU 5 %; PN KER 3026; SE 281; kv. 08/B3

8. Odl. ostenja skodelice Sarius; severnoitalska reliefna sigilata; akantov list s pentljo v reliefu; PN KER 0742; SE 395; kv. 12/A3

9. Odl. ostenja skodelice Sarius; severnoitalska reliefna sigilata; palma v reliefu; PN KER 1190; SE 101; kv. 00/C2

10. Odl. ostenja skodelice Sarius; severnoitalska reliefna sigilata; akantovi listi v reliefu; PN KER 0984; SE 101; kv. 26/C4

11. Odl. ostenja skodelice Sarius; severnoitalska reliefna sigilata; palma in dvojna linija iz listkov v reliefu; PN KER 3171; SE 297.B; kv. 08/C3

12. Odl. ostenja skodelice Sarius; severnoitalska reliefna sigilata; niz krogov v reliefu; PN KER 2903; SE 610; kv. 04/A1.

Tabla 6

*Vzhodna sigilata B2*

1. Odl. krožnika oblike Hayes 60; vzhodna sigilata B2; OHU 15 %; OHD 5 %; PN KER 3044; SE 288.B; kv. 07/E3

2. Odl. ustja in ostenja krožnika oblike Hayes 60; vzhodna sigilata B2; OHU 15 %; PN KER 1004; SE 118; kv. 26/D2

3. Odl. ustja in ostenja krožnika oblike Hayes 60; vzhodna sigilata B2; rahlo prežgano; OHU 10 %; PN KER 2983; SE 552; kv. 00/C2

4. Odl. ravnega dna krožnika oblike Hayes 60; vzhodna sigilata B2; OHD 20 %; PN KER 2023; SE 240; kv. 08/B3

5. Odl. ravnega dna krožnika oblike Hayes 60; vzhodna sigilata B2; OHD 10 %; PN KER 1935; SE 543; kv. 27/C4

6. Odl. ustja in ostenja skodelice oblike Hayes 80; vzhodna sigilata B2; OHU 25 %; PN KER 1693; SE 209.A; kv. 07/C3

7. Odl. ustja in ostenja skodelice oblike Hayes 80; vzhodna sigilata B2; OHU 10 %; PN KER 2989; SE 240; kv. 08/A3

8. Odl. ustja skodelice oblike Hayes 80; vzhodna sigilata B2; OHU 5 %; PN KER 2918; SE 282.B; kv. 07/B2

9. Odl. prstanastega dna skodelice oblike Hayes 80; vzhodna sigilata B2; OHD 25 %; PN KER 1373; SE 101; kv. 00/C2

10. Odl. prstanastega dna in ostenja skodelice oblike Hayes 80; vzhodna sigilata B2; OHD 50 %; PN KER 3131; SE 240; kv. 08/A3

Tabla 7

## Vzhodna sigilata B2

1. Odl. ustja krožnika oblike Hayes 62A; vzhodna sigilata B2; OHU 10 %; PN KER 1292; SE 209.A; kv. 07/D3
2. Odl. ustja in ostenja krožnika oblike Hayes 62B; vzhodna sigilata B2; OHU 16 %; PN KER 0976; SE 1; kv. 27/B2
3. Odl. ustja in ostenja skodelice oblike Hayes 74A; vzhodna sigilata B2; OHU 12 %; PN KER 0999; SE 118; kv. 26/D2
4. Odl. ustja in ostenja skodelice oblike Hayes 74A; vzhodna sigilata B2; OHU 25 %; PN KER 1057; SE 101; kv. 26/B3
5. Odl. ustja in ostenja skodelice oblike Hayes 74A; vzhodna sigilata B2; rahlo prežgano; OHU 35 %; PN KER 2048; SE 240; kv. 08/C3
6. Odl. ustja in ostenja skodelice oblike Hayes 74A; vzhodna sigilata B2; OHU 15 %; PN KER 0474; SE 159; kv. 26/B2
7. Odl. ustja in ostenja skodelice oblike Hayes 74A; vzhodna sigilata B2; OHU 5 %; PN KER 0640; SE 101; kv. 26/C3

8. Odl. ustja in ostenja skodelice oblike Hayes 75; vzhodna sigilata B2; OHU 10 %; PN KER 0958; SE 101; kv. 27/B3
9. Odl. ustja krožnika oblike Hayes 63; vzhodna sigilata B2; OHU 5 %; PN KER 0647; SE 386; kv. 12/B5.
10. Odl. ustja in ostenja skodelice oblike Hayes 76A; vzhodna sigilata B2; OHU 5 %; PN KER 2387; SE 543; kv. 27/C4
11. Odl. ustja in ostenja skodelice oblike Hayes 76A; vzhodna sigilata B2; OHU 5 %; PN KER 1494; SE 202; kv. 08/F3
12. Odl. ustja in ostenja skodele oblike Hayes 76B; vzhodna sigilata B2; OHU 10 %; PN KER 0718; SE 101; kv. 27/A5;
13. Odl. dna skodelice oblike Hayes 76; vzhodna sigilata B2; žig palmete; OHD 20 %; PN KER 0239; SE 118; kv. 26/C4
14. Odl. ravnega dna skodelice oblike Hayes 71 ali manjše-ga krožnika oblike Hayes 60; vzhodna sigilata B2; žig rozete; OHD 15 %; PN KER 2355; SE 240; kv. 08/B3
15. Odl. prstanastega dna krožnika oblike Hayes 77; vzhodna sigilata B2; OHD 15 %; PN KER 1106; SE 118; kv. 26/C3,4

- BIONDANI, F. 1992, Importazioni di ceramica africana e orientale a Suasa e nell'area medio e altoadriatica. - *Rivista di Studi Liguri* 58, 147-178.
- BOSIO, L. 1991, *Le strade romane della Venetia e dell'Histria*. - Padova.
- BROGIOLO, G. P. in G. OLCESE 2000, *Produzione ceramica in area Padana tra il II secolo a.C. e il VII secolo d.C. Nuovi dati e prospettive di ricerca*. - Documenti di Archeologia 21, Mantova.
- BRUKNER, O. 1981, *Rimska keramika u Jugoslovenskom delu provincije Donje Panonije*. - Dissertationes et monografie 24, Beograd, Ljubljana.
- BRUSIĆ, Z. 1999, *Hellenistic and Roman Relief Pottery in Liburnia (North-East Adriatic, Croatia)*. - BAR International Series 817, Oxford.
- BUORA, M. 2001, Elementi delle culture Veneta, Romana e Celtica nella Bassa Friulana. - *Antichità Altoadriatiche* 48, 151-185.
- Consp.: Ettlinger, E. et al. 1990, *Conspetus formarum terrae sigillatae Italico modo confectae*. - Materialien zur römisch-germanischen Keramik 10, Bonn.
- CVArr: Oxé, A. in H. Comfort 1968, *Corpus Vasorum Arretinorum. A Catalogue of the signatures, Shapes and Chronology of Italian Sigillata*. - Bonn.
- DEGRASSI, A. 1954, *Il confine nord-orientale dell'Italia romana. Ricerche storico topografiche*. - Bern.
- DUGULIN, A. (ur.) 2002, *La necropoli di San Servolo. Veneti, Istri, Celti e Romani nel territorio di Trieste*. - Trieste.
- GALLI, M. 2001, Per un'analisi della ceramica domestica come indicatore culturale. Note preliminari nel caso della colonia romana Ariminum. - *Antichità Altoadriatiche* 49, 217-254.
- GASSNER, V. 1997, *Das Südtor der Tetragonos-Agora. Keramik und Kleinfunde*. - Forschungen in Ephesos 13/1/1, Wien.
- GRÜNEWALD, M. 1983, Die Funde aus Schütthugel des Legionslagers von Carnuntum. - *Der römische Limes in Österreich* 32.
- HAYES, J. W. 1985, Sigillate orientali. - V: *Enciclopedia dell'Arte Antica. Atlante delle forme ceramiche* 2, 1-95, Roma.
- HORVAT, J. 1997, *Sermin. Prazgodovinska in zgodnjerska naselbina v severozahodni Istri*. - Opera Instituti Archaeologici Sloveniae 3, Ljubljana.
- HORVAT, M. 1999, *Keramika. Tehnologija keramike, tipologija lončenine, keramični arhiv*. - Razprave Filozofske fakultete, Ljubljana.
- Inscr. It. X, 1: Forlati Tamaro, B. 1974, *Inscriptiones Italiae Vol. 10, Regio X, Fasciculus 1. Pola et Nesactium*. - Roma.
- ISTENIČ, J. 1987, Rodik - grobišče Pod Jezerom. - *Arheološki vestnik* 38, 69-136.
- ISTENIČ, J. 1999, *Poetovio, zahodna grobišča 1. Grobne celote iz Deželnega muzeja Joanneum v Gradcu*. - Katalogi in monografije 32, Ljubljana.
- JURIŠIĆ, M. 2000, *Ancient Shipwrecks in Adriatic*. - BAR International Series 828, Oxford.
- KENRICK, P. M. 1985, *Excavations at Sidi Khrebish Benghazi (Berenice)*. Vol. 3. Part. 1 *The Fine Pottery*. - Lybia Antiqua. Supplement 5, Tripoli.
- KENRICK, P. M. 2000, Stamped sigillata from Northern Italy. Patterns of distribution. - V: Brogiolo, Olcese 2000, 47-52.
- KOŠČEVIĆ, R. in R. MAKJANIĆ 1995, *Siscia. Pannonia Superior*. - BAR International Series 621, Oxford.
- LABUD, G. 1995, *Ricerche archeologico-ambientali dell'Istria settentrionale. La valle del fiume Risano*. - Studies in Mediterranean Archaeology and Literature, Pocket-book 130, Jonsered.
- LAVIZZARI PEDRAZZINI, L. 1985, Terra sigillata. - V: Sena Chiesa 1985, 341-387.
- LETTICH, G. 1979, Appunti per una storia del territorium originario di Tergeste. - *Archeografo Triestino* ser. IV, 39, 9-113.
- MAGGI, P. 2001, La ceramica fine da mensa. - V: Tassaux, Matijašič, Kovačić 2001, 128-176.
- MAGGI, P. 2002, Ceramica. - V: Dugulin 2002, 98-119.
- MAGGI, P. in A. STARAC 2000, Rinvenimenti di terra sigillata e di altre ceramiche fini di produzione orientale in Istria. - *RCRF Acta* 36, 349-357.
- MAIOLI, M. G. 1983, La ceramica fine di mensa (terra sigillata). - V: Bermond Montanari (ur.) 1983, *Ravenna e il Porto di Classe*, 87-112, Imola.
- MAIOLI, M. G. 1990, Appendice I. Classe. La cultura materiale. - V: G. Susini (ur.) 1990, *Storia di Ravenna 1. L'età antica*, 415-455, Ravenna.
- MAKJANIĆ, R. 1983, Istočna sigilata na Kvarneru. - *Prinosi Odjela za arheologiju* 1, 51-64.
- MAKJANIĆ, R. 1985, Terra sigillata iz rimskih nekropola u Osoru i Bakru. - *Prilozi Odjela za arheologiju* 2, 39-50.
- MAKJANIĆ, R. 1987, Plain Italian Sigillata on the NorthEast Adriatic Coast and at Sisak. - *RCRF Acta* 25/26, 225-240.
- MAKJANIĆ, R. 1989, Notes on Later Arretine and "North Italian" Plain Sigillata Supply. - *Institute of Archaeology Bulletin* 25, 55-65.
- MANDRUZZATO, L., C. TIUSSI in V. DEGRASSI 2000, Appunti sull'Instrumentum d'importazione greca ed orientale ad Aquileia. - *RCRF Acta* 36, 359-364.

- MARGETIĆ, L. 1979-1980, Accenni ai confini augustei del territorio tergestino. - *Atti del Centro di ricerche storiche di Rovigno* 10, 75-101 (v hrv.: Napomene o Augustovim granicama tergestinskog agera. - *Dometi* 12, 1988, 773-788).
- MASELLI SCOTTI, F. 1987, Terre sigillate di Aquileia e Tergeste. Produzioni italice e importazioni galliche e orientali. - *RCRF Acta* 25-26, 207-224.
- MASELLI SCOTTI, F. (ur.) 1997, *Il Civico Museo Archeologico di Muggia*. - Trieste.
- MATIJAŠIĆ, R. 1991, *Campus Martius. Antička nekropola između Premanturske i Medulinske ulice u Puli*. - Monografije i katalozi 8, Pula.
- MATIJAŠIĆ, R. 1998, *Gospodarstvo antičke Istre. Arheološki ostaci kao izvori za poznavanje društveno gospodarskih odnosa u Istri u antici (I. st. pr. Kr. - III. st. posl. Kr.)*. - Povijest Istre 4, Pula.
- MAZZEO SARACINO, L. 1985, Terra sigillata nord-italica. - V: *Enciclopedia dell'Arte Antica. Atlante delle forme ceramiche* 2, 175-230, Roma.
- MAZZEO SARACINO, L. 2000, Lo studio delle sigillate padane. Problemi e prospettive. - V: Brogiolo, Olcese 2000, 29-43.
- MERLATTI, R. 2003, La produzione della ceramica grigia nell'Alto Adriatico. I rinvenimenti di Aquileia, Pozzuolo del Friuli e Palazzolo dello Stella. - *Quaderni Giuliani di Storia* 34/1, 7-41.
- MIKL CURK, I. 1996, Simonov zaliv - Terra sigillata from the first field campaigns. - *Opuscula Romana* 20, 249-253.
- MILLET, M. 1979, How much pottery? - V: M. Millet (ur.), *Pottery and the Archaeology*, Institute of Archaeology Occasional Paper 4, 77-80, London.
- NOVŠAK, M. 2003a, Križišče pri Sp. Škofijah. - V: D. Prešeren (ur.), *Zemlja pod vašimi nogami. Arheologija na avtocestah Slovenije. Vodnik po najdiščih*, 165-166, Ljubljana.
- NOVŠAK, M. 2003b, Školarice pri Spodnjih Škofijah. - V: B. Djurić (ur.), *Zemlja pod vašimi nogami. Arheologija na avtocestah Slovenije. Vodnik po najdiščih*, Zavod za varstvo kulturne dediščine Slovenije, 258-259, Ljubljana.
- OBERSLER, R. 1995, Trento - Pallazzo Tabarelli. Ceramica in terra sigillata. - V: E. Cavada (ur.), *Materiali per la storia urbana di Tridentum*, Archeoalp - Archeologia delle Alpi 3, 271-359.
- OCK: Oxé, A., H. Comfort, in P. M. Kenrick 2000, *Corpus Vasorum Arretinorum. A Catalogue of the Signatures, Shapes and Chronology of Italian Sigillata*. - 2nd edition, Bonn.
- OLCESE, G. (ur.) 1994, *Ceramica romana e archeometria. Lo stato degli studi*. Atti delle Giornate Internazionali di Studio (Castello di Montegufoni, Firenze, 26-27 aprile 1993). - Firenze.
- ORTON, C. 1989, An introduction to the quantification of assemblages of pottery. - *Journal of Roman Pottery Studies* 2, 94-97.
- PETRU, P. 1972, *Emonske nekropole*. - Katalogi in monografije 7, Ljubljana.
- PICON, M. 1994, Les sigillées italiennes et leur étude en laboratoire. - V: Olcese 1994, 47-61.
- PICON, M. 2000, Recherches préalables en vue de la détermination de l'origine des céramiques padanes à vernis noir et à vernis rouge. - V: Brogiolo, Olcese 2000, 91-101.
- PRÖTTEL, P. M. 1996, *Mediterrane Feinkeramikimporte des 2. bis 7. Jahrhunderts n. Chr. im Oberen Adriarum und in Slowenien*. - Kölner Studien zur Archäologie der römischen Provinzen 2, Köln.
- SCHINDLER, M. in S. SCHEFFENEGGER 1977, *Die glatte rotte Terra Sigillata vom Magdalensberg*. - Kärntner Museumsschriften 62, Archäologische Forschungen zu den Grabungen auf dem Magdalensberg 5, Klagenfurt.
- SCHINDLER-KAUDELKA, E. 1980, *Die römische Modelkeramik vom Magdalensberg*. - Kärntner Museumsschriften 66, Archäologische Forschungen zu den Grabungen auf dem Magdalensberg 7, Klagenfurt.
- SCHINDLER-KAUDELKA, E. 1995, Die italische Sigillata aus dem vicus von Gleisdorf. - V: T. Lorenz, C. Maier, M. Lehner (ur.), *Der Römische vicus von Gleisdorf. Bericht über die Ausgrabungen 1988-1990*, 65-85, Graz.
- SCHINDLER-KAUDELKA, E. 1998, Die Modelkeramik vom Magdalensberg 2, Die Norditalica Decorata vom Südhang des Magdalensberg. - V: G. Piccottini (ur.), *Die Ausgrabungen auf dem Magdalensberg 1980 bis 1986*, 289-388, Klagenfurt.
- SCHINDLER-KAUDELKA, E. 2000, Ceramica norditalica decorata del Magdalensberg. Problemi aperti. - V: Brogiolo, Olcese 2000, 53-67.
- SCHINDLER-KAUDELKA, E. in D. GROH 1994, Die italische Sigillata aus Flavia Solva. - *Fundberichte aus Österreich* 33, 357-391.
- SCHINDLER-KAUDELKA, E., G. SCHNEIDER, in S. ZABEHLICKY-SCHEFFENEGGER 1997, Les sigillées padanes et tardo-padanes. Nouvelles recherches en laboratoire. - *S. F. E. C. A. G., Actes du Congrès du Mans*, 481-494, Marseille.
- SCHINDLER-KAUDELKA, E., U. FASTNER in M. GRUBER 2001, *Italische Terra Sigillata mit Appliken in Noricum*. - Österreichische Akademie der Wissenschaften Philosophisch - Historische Klasse Denkschriften 298, Archäologische Forschungen 6, Wien.
- SCHNEIDER, G. 2000a, X-ray fluorescence analyses of vernice nera, sigillata and Firmalampen from North Italy. - V: Brogiolo, Olcese 2000, 103-106.
- SCHNEIDER, G. 2000b, Chemical and mineralogical studies of late hellenistic to byzantine pottery production in the Eastern Mediterranean. - *RCRF Acta* 36, 525-535.
- SENA CHIESA, G. 1985, *Angera romana. Scavi nella necropoli 1970-1979*. - *Achaeologica* 44, Milano.
- SLANE, K. W. 2000, East-west trade in fine wares and commodities. The view from Corinth. - *RCRF Acta* 36, 299-312.
- STARAC, A. 1999, *Rimsko vladanje u Istriji i Liburniji, I Istrija*. - Monografije i katalozi 10/1, Pula.
- STOKIN, M. 1990, La diffusione della ceramica a vernice nera in Istria. - *Aquileia Nostra* 61, 161-168.
- STOKIN, M. 1992, Naselbinski ostanki iz 1. st. pr. n. št. v Fornačah pri Piranu. - *Arheološki vestnik* 43, 79-92.
- STOKIN, M. 2001, Simonov zaliv. Antična vila. - *Annales. Series historia et sociologia* 11, 405-412.
- STOKIN, M. in S. KARINJA 2004, Rana romanizacija i trgovina u sjeverozapadnoj Istri s naglaskom na materijalnu kulturu. - *Histria Antiqua* 12, 45-54.
- STRAZZULA RUSCONI, M. J. 1979, Scavo di una villa romana a Joannis. - *Aquileia Nostra* 50, 25-68.
- ŠONJE, A. 1991, *Putevi i komunikacije u prehistoriji i antici na području Poreštine v njihov odnos prema ostalim prometnim vezama u Istri*. - Poreč, Pazin.
- TASSAUX, F. 2004, Les Importations de l'Adriatique et de l'Italie du Nord vers les provinces danubiennes de César aux Sévères. - V: G. Urso (ur.) 2004, *Dall'Adriatico al Danubio. L'Illirico nell'età greca e romana*, I convegni della fondazione Nicolò Canussio 3, 167-205, Pisa.
- TASSAUX, F., R. MATIJAŠIĆ in V. KOVAČIĆ 2001, *Loron (Croatie)*. - Bordeaux.
- TOPIĆ, M. 2003, Stolno posude i glinene svjetiljke iz Augusteuma Narone. - *Vjesnik za arheologiju i historiju dalmatinsku* 95, 183-244.
- TRENTZ, A., M. NOVŠAK, J. BURMAZ, B. ROZMAN, T. ŽERJAL, S. FIRŠT in J. HRUSTEL 2002, *Poročilo na arheoloških izkopavanjih na lokaciji Školarice na trasi AC Klanec-Sermin*. - Piran (neobjavljen tipkopi).
- TRENTZ, A., M. NOVŠAK, R. KLASIN, T. ŽERJAL, J. BURMAZ, B. ŠTULAR in B. ROZMAN 2003, *Poročilo o arheoloških izkopavanjih na lokaciji Križišče na trasi AC Klanec*

- Ankaran. *Srmin-Socerb.* - Piran (neobjavljen tipkopolis).
- TRENZ, A. in M. NOVŠAK 2004, Villa rustica na lokalitetu Školarice na trasi autoputa Klanec - Ankaran. - *Histria Antiqua* 12, 77-84.
- VEDALDI IASBEZ, V. 1994, *La Venetia orientale e l'Histria. Le fonti letterarie greche e latine fino alla caduta dell'Impero Romano d'Occidente.* - Studi e ricerche sulla Gallia Cisalpina 5, Roma.
- VENTURA, P. 1991, Terra sigillata orientale. - V: Verzar-Bass 1991, 114-118.
- VENTURA, P. 1994, Terra sigillata orientale. - V: Verzar-Bass 1994, 121-125.
- VERZAR BASS, M. (ur.) 1991, *Scavi di Aquileia. L'area a est del Foro. \*Rapporto degli Scavi 1988.* - Studi e ricerche sulla Gallia Cisalpina 3, Aquileia.
- VERZAR BASS, M. (ur.) 1994, *Scavi di Aquileia. L'area a est del Foro. \*\*Rapporto degli Scavi 1989-91.* - Studi e ricerche sulla Gallia Cisalpina 6, Aquileia.
- VIČIČ, B. 1997, Rimske najdbe izpod Miklavškega hriba pri Celju. - *Arheološki vestnik* 48, 41-51.
- VIDRIH PERKO, V. 1997, Rimskodobna keramika z Ajdovščine pri Rodiku. - *Arheološki vestnik* 48, 341-358.
- VIDRIH PERKO, V. in M. PAVLETIČ 2000, Report on ceramics from Brijuni. - *RCRF Acta* 36, 263-269.
- VOLONTÉ, M. 1996, Le terre sigillate. - V: L. Passi Pitcher (ur.) 1996, *Bedriacum. Ricerche archeologiche a Calvatone 1.2. Campo del Generale. I materiali del saggio* 6, 105-118, Milano.
- ZABEHLICKY-SCHEFFENEGGER, S. 1992, Terra sigillata tardo-padana. - *RCRF Acta* 31-32, 415-443.
- ZABEHLICKY-SCHEFFENEGGER, S. in R. SAUER 2000, Metodi di distinzione dei due gruppi di sigillata padana augustea trovati sul Magdalensberg. - V: Brogiolo, Olcese 2000, 67-78.
- ZACCARIA, C. 1992, Regio X. Venetia et Histria. Ager Tergestinus ed Tergesti adtributus. - *Supplementa Italica* n. s. 10, 139-283.

## Sigillata from Školarice near Spodnje Škofije

### Trade with sigillata ware in northern Istria during the 1<sup>st</sup> and 2<sup>nd</sup> centuries AD

#### Summary

#### INTRODUCTION

The construction of the Slovene motorway at the section from Klanec to Sermin brought about archaeological rescue excavations at Školarice near Spodnje Škofije in 2002<sup>1</sup> (Trenz et al. 2002; Trenz, Novšak 2004; Novšak 2003b). Roman finds were first documented at this site already in the early 1990s during the surveying done by Giordano Labud (1995, 51), whose interest was a detailed topography of the Rižana valley. The importance of the site was later confirmed by primary archaeological research (intensive field surveying, geophysical measurements, and test trenching), conducted prior to motorway construction.

The excavation that ensued revealed an extensive architectural complex of a *villa rustica* with a residential and a production area, sited on the lower slope of the Bečajevec hill. Most of the southern part of the residential architecture had, unfortunately, been completely destroyed during the construction of the Iplas factory in the 1960s. Other parts of the villa revealed archaeological layers preserved to various degrees, affected by the intensive agricultural activities and terracing conducted there during the last few centuries. The layers were,

at places, destroyed almost to the bedrock while elsewhere, particularly on the inner sides of the terrace walls, they were relatively well preserved. The western part of the complex revealed a baths area, preserved only in foundations underneath a walking surface. A large part of the villa's production area in the northern part was also investigated, including a large storage area with an interior colonnade and a set of smaller rooms.

The preliminary analysis of small finds revealed the lifespan of the villa from the second quarter or the mid 1<sup>st</sup> to the mid 5<sup>th</sup> centuries AD (see below).

The slightly elevated position of the complex commanded a panoramic view over the entire Koper bay, with the Sermin hill in front of it, and, more significantly, over the fertile plain of the Rižana valley, which was probably where the most important of the villa's economic activities were conducted.

The villa lies on the right bank of the Rižana river - the ancient *Formio*. According Pliny (N. H. III, 127), the river represented the old borderline of Italy. Augustus then transferred the border to the Raša river - the ancient *Arsia* in eastern Istria towards the end of the 1<sup>st</sup> century BC (basic work by Degrassi 1954, 54-60; synthesis of later opinions by Vedaldi Iasbez 1994, 39, 44-45, 127-128, 419, and particularly by Starac 1999, 15, 57-60). The borderline of Italy had therefore been

<sup>1</sup> This article forms part of the process of analysing the excavated material, which will be fully evaluated, together with the stratigraphical data, in a monographical publication of the *Archaeology on Slovene Motorways (Arheologija na avtocestah Slovenije)* series. I would like to thank Alfred A. Trenz (Institute for the Protection of Cultural Heritage of Slovenia, Regional Office in Piran) and Matjaž Novšak (Arhej d. o. o.) who kindly entrusted me with the analysis of the pottery finds. For critical reading and constructive notes I would like to thank Dr. Verena Vidrih Perko, university lecturer (Museum of Gorenjska, Kranj), Dr. Božidar Slapšak (Department of Archaeology, Faculty of Arts in Ljubljana), associate professor and mentor, and, most of all, my research mentor Dr. Jana Horvat (Institute for Archaeology at ZRC SAZU). Most of the drawings were done by Dragica Knific Lunder (Institute for Archaeology at ZRC SAZU), some also by Katarina Vladimirov under the guidance of Simona Tomažič (Arhej d. o. o.). Scanning was done by Lučka Šoberl and Drago Valoh (Institute for Archaeology at ZRC SAZU), while the map was drawn by Mateja Belak (Institute for Archaeology at ZRC SAZU). The summary was translated by Andreja Maver. The article is part of the junior researcher training programme at the Institute for Archaeology at ZRC SAZU, financed by the Ministry of Higher Education, Science and Technology.



situated deep within Istria for several decades before the construction of the Školarice villa began. Contemporaneously to the border, the Tergeste ager had been extended southwards to the Mirna river (Margetić 1979-1980; Lettich 1979; Zaccaria 1992, 163-164; Vedaldi Iasbez 1994, 422; Starac 1999, 110-119).

The villa lay relatively close to Tergeste (8 km), tied to it by excellent road communications. The latter was represented by the main Istrian road between Tergeste and Pola that ran underneath the foot of the hill. This Roman road almost certainly used the older, already existing prehistoric one. Istria's road network was probably constituted soon after the territory had been conquered, but definitely contemporaneously with the establishment of *coloniae* and *municipia* during the second half of the 1<sup>st</sup> century BC (Šonje 1991, 9-10, 38; Matijašić 1998, 418-419). The above-mentioned *via publica* between Trieste (Tergeste) and Pola (Pola), named *Via Flavia*, was arranged according to the act by Vespasian and Titus in the years AD 78-79, as attested by the milestones of the southern Istrian peninsula (*Inscr. It. X*, 1, 705-706; Bosio 1991, 223). The exact route across the Rižana plain underneath Školarice was confirmed by excavations in the winter of 2002/2003. The latter also revealed roads that branch towards Ankaran and the Školarice villa, as well as a Roman cemetery along the main road (Trenz et al. 2003; Novšak 2003a).

The analysis of the pottery from Školarice villa begins with the sigillata ware from the 1<sup>st</sup> and 2<sup>nd</sup> centuries AD. Sigillata and thin-walled pottery are fine wares that developed under the strong influence of metal ware. They indirectly mirrored cultural and social conditions as well as trade routes. While the cooking ware, with its functional and non-representational character had a long tradition, a high degree of stability, and a resistance to new elements, the fine ware, on the other hand, was subject to rapid changes (Galli 2001, 225). By researching the sigillata ware, this chronologically highly sensitive merchandise, at this early stage of research, we were trying to answer two questions: when was the villa constructed and how was the broader area around it incorporated into the economic currents of the early Imperial period? The complete picture of the life at the villa, however, will only be possible with the analysis of all pottery types and other finds as well as stratigraphy and architectural remains.

The long duration of the villa and the poor preservation of the archaeological layers in many parts influenced the early sigillata ware to be preserved in a fragmented state. The highest concentration of sigillata was detected in the baths area (sectors 0, 26, and 27) as well as in areas southeast of the large storage area (sectors 7 and 8). The latter (parts of sectors 5-7, 9-11) failed to reveal any sigillata ware. The adjoining rooms to the east (sectors 11-13), in all likelihood places of the villa's economic activities, revealed only a few fragments. Since it is not as yet possible to present closed sets with telling material, diagnostic pieces<sup>2</sup> of the sigillata ware were used in the research of the early period of the villa (*Table 1*).<sup>3</sup>

<sup>2</sup> For statistical and analytical purposes, fragments of rims, handles, grips, bases, and decorated walls were selected from the body of finds. Only the undecorated wall fragments were not analyzed, considered not to substantially influence the ratios of the different pottery types.

<sup>3</sup> The values were obtained on the basis of all the diagnostic pieces. These were first distributed into *sherd families* that undoubtedly belong to the same vessel and then determined by fabric and type. The estimated maximum number of vessels represents the highest possible number of vessels to which the fragments could belong. The fragments of the same form and fabric that do not have fitting fractures supposedly belonged to different vessels. The estimated minimum number of vessels, on the other hand, is based on the assumption that fragments of equal form and fabric formed a single vessel if not explicitly proved to the contrary (Millet 1979, 77; Orton 1989, 94). The following analysis consistently uses values of the minimum number of vessels.

<sup>4</sup> The term is used for the entire sigillata production of Roman Italy.

<sup>5</sup> By Arretine sigillata its fabric A is meant, as defined by Maria Schindler. She divided the Magdalensberg sigillata according to the macroscopic characteristics of clay, slip, particular formal characteristics of vessels, and producer's stamps (Schindler, Scheffenegger 1977, 17).

#### ITALIAN SIGILLATA<sup>4</sup>

Italian sigillata of the 1<sup>st</sup> and 2<sup>nd</sup> centuries constitutes the largest pottery group of fine sigillata ware at Školarice, its share reaching 72.6% (*Table 1* - values of the estimated minimum number of vessels represented). It is characteristic of the early habitation of the villa. A modest share of it belongs to Arretine sigillata, imported from central Italy. The majority of it, however, was produced in the workshops of the nearby Po valley. This is not surprising, since the sigillata of the northern Adriatic production predominates across the entire northern Adriatic region during the 1<sup>st</sup> and the first half of the 2<sup>nd</sup> centuries (Makjanić 1989, 61; Maggi 2001). The Školarice material revealed fragments of North Italian sigillata B (It. *sigillata Padana B*) from the first half of the 1<sup>st</sup> century, its contemporary North Italian relief-decorated sigillata (It. *sigillata norditalica decorata*) as well as the so-called *sigillata Tardopadana* from the second half of the 1<sup>st</sup> and the first half of the 2<sup>nd</sup> centuries.

#### Arretine sigillata<sup>5</sup>

Arretine sigillata represents only a small portion (4%) of the sigillata ware from Školarice. A more precise determination of the production centre, whether Arezzo itself or perhaps other related centres of central Italy (e.g. Pisa), cannot be given by macroscopic observation alone. From central Italy, this type of pottery probably came to the northern Adriatic along the west Adriatic coast, via Rimini, Adria, and Ravenna. From there the route could lead directly across the sea to the coastal cities of Istria as well as indirectly via Aquileia, which functioned as the main distribution centre (Maggi 2001, 149, 158).

The earliest example of Arretine sigillata is a rim fragment of a conical Consp. 22.1 cup (*Pl. 1: 1*). This type of cups, the most widely spread one, was produced in several variants by all the main sigillata workshops between the 20s BC and AD 30s. Its characteristic is rouletted decoration on a tripartite vertical moulded rim (Consp. 1990, 90).

The cylindrical Consp. 26.2 cup (*Pl. 1: 2*) has groove-decorated walls. It is dated to the first half of the 1<sup>st</sup> century. This date is based on the observation that the Consp. 26 cups appear sporadically on Magdalensberg at the turn of the century but become more frequent later, particularly within the contexts of the AD 20/25 - 45 period (Schindler, Scheffenegger 1977, 205; Consp. 1990, 98).

The rim fragment on *Pl. 1: 3* probably belongs to a dish with a curving wall and quarter-round moulding of the Consp. 6.2 form, dated to the late Augustan to Claudian periods (Schindler-Kaudelka, Fastner, Gruber 2001, 143). Together with contemporary Consp. 4.6 dishes, Schindler (1977, 131) supposed, on the basis of the Magdalensberg material, that the Consp. 6.2 form also underwent a morphological development from low, very open forms with a small rim and emphasized feet, to higher forms, with an inwardly turning rim, strongly rounded exteri-

or profile, and a higher as well as thinner foot. Subsequent analyses went to confirm this supposition only for the Arretine products (Schindler-Kaudelka, Fastner, Gruber 2001, 129). The fragment on *Pl. I: 3* could therefore typologically be determined as an early example.

Dishes were often covered with rouletted decoration on the interior base surface. The fragments discovered at Školarice (*Pl. I: 4*; and unpublished pieces) could therefore belong to forms Consp. 4 or 18-20 from the late Augustan - Tiberian to Claudian periods or to later Consp. 3 forms (Consp 1990, 148).

The youngest fragments from the Arretine workshops (*Pl. I: 5,6*) belong to dishes with a vertical rim of the Consp. 20.4 form. They were produced by the Arretine workshops during the reigns of Tiberius and Nero. They can, however, appear up to the end of the 1<sup>st</sup> century. They bear applied decorations, which distinguishes them from those made in the north Italian workshops. The rim of such a dish was decorated with eight appliques of various motifs, palm leaves with garlands, for example (*Pl. I: 5*; Schindler-Kaudelka, Fastner, Gruber 2001, 127, 143).

#### North Italian sigillata<sup>6</sup>

Pottery workshops in the Po valley quickly followed the Arretine example. The already existing production of black-slip pottery is joined by the new production technique of the red sigillata ware during the last quarter of the 1<sup>st</sup> century BC, at the latest. These production centres are not as yet known. Nevertheless, workshops of North Italian sigillata can be expected in many Po valley cities on the basis of confirmed workshops of black-slip pottery, finds of pottery waste of red sigillata, moulds, and pottery tools. The North Italian production is, in fact, very heterogeneous. It comprises products of a very high quality made from a well refined clay with a good shiny slip that are difficult to distinguish from the Arretine products. On the other hand, the products also include very porous examples with a diluted matt slip, as well as all quality levels in between (Mazzeo Saracino 2000, 38).

Chemical and mineralogical analyses have shown clear differences in the composition of Arretine and North Italian sigillatas. The latter are composed of clays rich in calcium carbonate that are characteristic of the sediments of the entire Po valley. Based on the presence of other chemical elements, the North Italian sigillata production can be divided

into several groups. Formal and macroscopic analyses of the Magdalensberg material allowed a clear determination of the North Italian B and C sigillata fabrics. These were later discovered to share the chemical composition. Fabric groups, therefore, do not necessarily represent different sources of raw clay, they may only indicate differences in production procedures, from the choice of clay in the vicinity of the workshop and its preparation, the procedure of drying, and, most of all, the manner, temperature, and duration of firing. The chemical composition of North Italian B and C sigillata also corresponds to the North Italian black-slip pottery, more precisely to those of porous fabric (*Poröses Fabrikat*) from Magdalensberg.<sup>7</sup> *Sigillata Tardopadana* constitutes a specific, clearly delimited chemical group, which is very broad and, for the moment, not divisible into subgroups (with the possible exception of fabric E).<sup>8</sup> Within the production of the North Italian relief-decorated sigillata, three different chemical groups were defined. Two-handled Sarius cups represent one, while the Aco beakers include two chemically different groups (Schindler-Kaudelka, Schneider, Zabehlicky-Scheffenecker 1997; Schneider 2000a; Schindler-Kaudelka, Fastner, Gruber 2001, 169-176).

Archaeometric analyses of the material from Bologna, Rimini, and Magdalensberg led Picon to determine eight groups of North Italian sigillata and to suppose 20 to 30 workshops (Picon 1994, 54).<sup>9</sup> At least part of the black-slip pottery workshops continued their production with red sigillata, probably in the central Po region in particular. Volcanic minerals, present in North Italian sigillatas B and C, indicate probable areas of production in the Euganea Hills, the hills between Verona and Vicenza, as well as the area of the southern tributaries of the Po around Modena and Piacenza (Zabehlicky-Scheffenecker, Sauer 2000, 73; cf. Picon 2000). The production centres of *sigillata Tardopadana*, on the other hand, are supposed to be situated in the area around Ticino, a supposition based on a few forms that appear exclusively in that area (Mazzeo Saracino 2000, 39).

The variety of pottery workshops across the north Italian area was complemented by local workshops on the edges of the Po valley, such as was documented at Loron in Istria, dated to the Augustan and Tiberian periods (Maggi 2001). Such workshops could satisfy the needs of their estate as well as supply the surrounding markets or buyers in a slightly broader, regional area. The use of Loron products, for example, was limited to the villa itself during the Augustan period. Later, in the Tiberian period, its products supplied a broader market as

<sup>6</sup> The term *North Italian sigillata* includes the entire sigillata production of North Italy during the Early and Middle Imperial periods: North Italian sigillata, *sigillata Tardopadana*, and the North Italian relief-decorated sigillata. The later sigillata productions are mostly excluded from the term and are not the topic of this article. Many publications do not explicitly distinguish between individual productions and older literature does not even distinguish the North Italian productions from other Italian sigillatas.

*North Italian Sigillata* (Kenrick 2000) can also be used for *terra sigillata Padana*, more commonly known under this or similar expressions, cf. Mazzeo Saracino 1985; id. 2000; Consp. 1990, 8-10; Brogiolo, Olcese 2000, for example; Vidrih Perko, Pavletić 2000; Kenrick 2000; Schneider 2000a; Schindler-Kaudelka, Fastner, Gruber 2001; Schindler-Kaudelka, Schneider, Zabehlicky-Scheffenecker 1997; Brukner 1981, 18-19; Istenič 1987; Vičič 1997; Vidrih Perko 1997, 349, or *North-Italian Plain Sigillata* (Makjanić 1989; Horvat 1997).

By analogy with the late Italian sigillata or *terra sigillata tardo-italica* in Italian, Zabehlicky-Scheffenecker (1992, 415) introduced the term *Terra sigillata tardo-padana (TSTP)* or shorter *Tardopadana* for *sigillata Tardopadana*, as it is termed here, cf. Istenič 1999, 90.

For decorated North Italian pottery, mainly Sarius cups and Aco beakers, see Horvat 1997, 168; e.g. Vičič 1997, Stokin 2001. Foreign literature uses term such as: *terra sigillata norditalica decorata* (Mazzeo Saracino 1985), *ceramica norditalica decorata* (Schindler-Kaudelka 2000), *produzione padana decorata*, *ceramica tipo Aco* or *ceramica tipo Sarius* (Mazzeo Saracino 2000, 39), *die Modelkeramik* (Schindler-Kaudelka 1980; ead. 1998), *Relief-decorated North-Italian sigillata* (Brusić 1999).

<sup>7</sup> For fabric definition of the North Italian sigillata see Schindler, Scheffenecker 1977, 18-19; Zabehlicky-Scheffenecker, Sauer 2000.

<sup>8</sup> For the definition of individual fabrics of *sigillata Tardopadana* see Grünwald 1983, 11; Schindler-Kaudelka 1995, 65-66; Schindler-Kaudelka, Groh 1995, 358-359; Schindler-Kaudelka, Fastner, Gruber 2001, 120-125.

<sup>9</sup> The entire North Italian sigillata production of the Early Imperial period is meant here.

well. This is indicated by the discovery of products bearing the workshop's stamp at the cemetery of Socerb (Maggi 2002), in Aquileia, Tergeste, Pola, and Emona (Maggi 2001, 130).

Arretine sigillata was spread across the Mediterranean, particularly in the western provinces. North Italian sigillata, on the other hand, has a slightly different distribution area. Products bearing the stamps of its workshops predominate in the entire Po region, they also frequently appear in the north-eastern provinces (Raetia, Noricum, Pannonia), along the entire Adriatic coast, and further southwards to Corinth and Knossos. Individual examples also appear in the western Mediterranean - in North Africa, Sicily, and Spain, though this is not likely to be the consequence of a stable trade network (Kenrick 2000).

The earliest examples of North Italian sigillata B at Školarice include forms, imitations of the Arretine models, that were used at the very onset of production - in the last quarter of the 1<sup>st</sup> century BC. The potters frequently altered the original form slightly. A rather coarse variant of the conical Consp. 22.6 cups (*Pl. 1: 9*) is thereby characteristic only for the North Italian production. Their production begins at the end of the 1<sup>st</sup> century BC. Comparably to the Arretine production, it reaches its peak during the Augustan and ends during the late Tiberian periods (Mazzeo Saracino 1985, 197; Consp. 1990, 90; Oberosler 1995, 287-289).

The production of the developed form of Consp. 18.2 dishes with a vertical concave-convex rim (*Pl. 1: 7,8*) occurred approximately contemporarily in both. In the Po valley, for example, they appear in the contexts spanning from the end of the 1<sup>st</sup> century BC to the mid 1<sup>st</sup> century AD (Mazzeo Saracino 1985, 198; id. 2000, 35; Lavizzari Pedrazzini 1985, 341, note 5, 344; Oberosler 1995, 290; Consp. 1990, 82 - the dating exclusively to the Tiberian period differs from all others).

Conical cups with an incurving rim of the Consp. 24.3 form (*Pl. 1: 10,11*) were also a particular feature of the North Italian workshops, dated from the mid-Augustan to the Claudian period (Mazzeo Saracino 1985, 197; Consp. 1990, 94; Oberosler 1995, 287-288). They are most frequent in Augustan and Tiberian contexts, in the complex IV of Magdalensberg from the early years of Tiberius' reign, for example (Schindler, Scheffenecker 1977, 115-119). The stamps on these cups lead Volonté (1996, 107-108) to suppose their production in the workshops of the northern Adriatic coast.

Certain forms of Arretine and North Italian sigillatas from the second quarter of the 1<sup>st</sup> century were taken over by the potters of *sigillata Tardopadana*. The novelty of the latter is the use of applied decoration, which appears on Arretine sigillata already at the turn of the century, while potters of North Italian B and C sigillata never use it (Schindler-Kaudelka, Fastner, Gruber 2001, 151). These "common" forms are present also at Školarice and belong to North Italian sigillata B and *sigillata Tardopadana*.<sup>10</sup> The two productions partially overlap in both form and time.

The above-mentioned forms of *sigillata Tardopadana*, decorated with appliqué, were classified as formal group A by Zabežlicky-Scheffenecker (1992, 415-416). The earliest products of this group (more precisely, its fabric D) appear at Magdalensberg just before the abandonment of the settlement around AD 50 (Schindler, Scheffenecker 1977, 20; Schindler-

Kaudelka, Fastner, Gruber 2001, 152-153). They are exceptionally frequent in the contexts of the Flavian period, with their share significantly higher than those of other *Tardopadana* forms. They also appear frequently in every layer of the first quarter of the 2<sup>nd</sup> century, their numbers only decreasing in the second quarter. The layers of the mid 2<sup>nd</sup> century in Noricum yielded but sporadic examples (Schindler-Kaudelka, Fastner, Gruber 2001, 153). The production of the most frequent forms (Consp. 20.4 dishes, Consp. 29 and Consp. 34 cups) undoubtedly lasted long into the 2<sup>nd</sup> century, since the youngest examples are found as parts of grave-groups from the time of Antoninus Pius. The production of the popular forms was gradually abandoned during the second half of the 1<sup>st</sup> century. The Consp. 4.6 in 6.2 dish forms thereby appear in graves at least until the Flavian period. Consp. 21 dishes can be found in Trajanic and Consp. 27 cups in Hadrianic graves, their production is therefore supposed to have lasted at least until the end of the 1<sup>st</sup> century (Zabežlicky-Scheffenecker 1992, 420-423, 442).

Most forms of the group A are characterized by their absence of change throughout their production period. Even the variants that would be particular to various pottery workshops cannot be distinguished (Schindler-Kaudelka, Fastner, Gruber 2001, 127, 152-153). Their distribution covered the entire Po valley, the northern Adriatic, and, in particular, the sites along the main land and river trade routes of the provinces of Noricum and Pannonia (Zabežlicky-Scheffenecker 1992, 419).

The highest number of North Italian sigillata fragments at Školarice belongs to cups with a pronounced flange of the Consp. 34 form (17.4% of the North Italian sigillata for the values of the minimum number of vessels; 4 examples of the North Italian and 11 of *sigillata Tardopadana*). The examples of the North Italian workshops (*Pl. 3: 1*) appear during the Tiberian period, they are rare and never decorated. Within the *Tardopadana* production (*Pl. 3: 2-8*), these cups are frequent and characteristic particularly for the eastern distribution area - for the northern Adriatic, Noricum, and Pannonia (Consp. 1990, 112; Zabežlicky-Scheffenecker 1992, 419). They were produced in two sizes: small (*acetabulum*), with a diameter of 7-9.5 cm or a volume just over an eighth of a litre, or large (*paropsis*), with a diameter of 11-13 cm or a volume of a quarter of a litre (Schindler-Kaudelka, Fastner, Gruber 2001, 138-139). At the Školarice site (*Pl. 3: 1-8*) the large ones seem to predominate, although the reliability of this observation is reduced by the fragmented state of the finds. The vessels can bear four to six appliqué on the exterior surface of the rim. Those in the form of small masks with short hair, named satyr heads (*Pl. 3: 3*), are only found on the *Tardopadana* Consp. 34 cups. Together with the appliqué of masks with long hair and a diadem they formed a pair, which could be further combined with pairs of dolphins and double spirals (Schindler-Kaudelka, Fastner, Gruber 2001, 72-73).

Dishes with a vertical rim of the Consp. 20.4 form (*Pl. 1: 12-14*) appear around AD 30 and are very frequent in the contexts of the mid 1<sup>st</sup> century across the entire Mediterranean (Consp. 1990, 86). They become one of the leading forms of the *sigillata Tardopadana* formal group A. At Školarice, they are present in equal numbers in both the North Italian sigillata B and *sigillata Tardopadana*. Similar and contemporaneous with them are dishes with a quarter-round moulding of the Consp. 21.3 form (*Pl. 1: 15*). The latter are much rarer in both productions. Most of the rims that could belong to either of the groups were therefore temporarily determined as the Consp. 20.4 form. The exterior

<sup>10</sup> The above-mentioned research of the last decade has shown a clear division between the products of the North Italian and the *Tardopadana* workshops. Despite this, most authors treat the North Italian production as a whole. For the poorly preserved pieces of the "common" forms it is, in fact, difficult to distinguish between the two on the basis of their macroscopic characteristics. Aside from this, the present chronology does not distinguish between individual productions, and the end of the North Italian sigillata B production is therefore still not clear. Due to the small number of vessels, and with clarity in mind, these forms are treated jointly.

perimeters of the rims were decorated with antithetical pairs of appliqués: rosettes (*Pl. 1: 13*), palm leaves with garlands, and masks (with long hair and a diadem, for example - *Pl. 1: 12*).

The popular cylindrical cups with a flat base of the Consp. 29 form (*Pl. 4: 12*) are not decorated with appliqués, but sometimes bear a moulded band on the exterior surface of the walls. Their lip fragments are, for the most part, difficult to distinguish from the cylindrical cups of the Consp. 27 form (*Pl. 1: 16,17*), produced from the Augustan period onwards also at Loron, in Istria (Maggi 2001, 131). The production of both cup forms of North Italian sigillata B ended approximately in the Claudian period (Consp. 1990, 100, 104; Oberosler 1995, 294) or slightly later, together with the end of the entire production (see note 8). Among *sigillata Tardopadana*, the Consp. 27 cups are rare. Its youngest examples were found in graves of the Trajanic period. Consp. 29 cups of the *Tardopadana* production, on the other hand, are particularly frequent in the western Po valley. Their production lasted until the mid 2<sup>nd</sup> century (Zabehlicky-Scheffenecker 1992, 419, 423).

The Tiberian period sees the appearance of dishes with a curving wall of the Consp. 4.6 type (*Pl. 2: 1*) and dishes with a quarter-round moulding of the Consp. 6.2 form (*Pl. 2: 2,3*), both developed from preceding forms. Those of the North Italian sigillata production are strictly without applied decoration up to the Claudian period, when the potters of *sigillata Tardopadana* begin to apply, most frequently hand-made, double spirals and mould-made appliqués in the form of rosettes, dolphins, and masks (Schindler-Kaudelka, Fastner, Gruber 2001, 129-130). The *Tardopadana* examples (*Pl. 2: 3*) are relatively rare and sporadically appear up to the end of the 1<sup>st</sup> century (id. 124,143).

The hemispherical cups of the Consp. 36.4 form (*Pl. 2: 4,5*) are also rare at Školarice. Though widely spread already during the Tiberian period (North Italian sigillata B), their production nevertheless continues much longer (*sigillata Tardopadana* - *Pl. 2: 4,5*). The latter is attested to by the cemetery at Angera, where they were found as grave goods during the Hadrianic and Severan periods (Lavizzari Pedrazzini 1985, 350-351).

The dish with a straight sloping wall and bead rim of the Consp. 3 form (*Pl. 2: 7-13*) represent one of the most frequent forms in the contexts of the second half of the 1<sup>st</sup> century across the Mediterranean, particularly within the late Italian production of central Italy (It. *terra sigillata taroitalica*).<sup>11</sup> It appears at Magdalensberg and Bolsena already slightly prior to the mid 1<sup>st</sup> century, and predominates at Pompeii and the Domitianic layers of Ostia somewhat later (Kenrick 1985, 177; Consp. 1990, 56). The dated examples of *sigillata Tardopadana* are found in grave-groups from the Neronian to the Antonine periods (Zabehlicky-Scheffenecker 1992, 421). This indicates that their production lasted long into the 2<sup>nd</sup> century. Consp. 3 dishes of the *Tardopadana* production do not predominate in Noricum (id. 416). Those of the late Italian production, on the other hand, show a predominance throughout the Mediterranean. Their share among the North Italian sigillata from Školarice (16,3% for values of the minimum number of vessels) is extremely high, equal even to the share of the Consp. 34 cups (17,4% for the values of the minimum number of vessels). The fourteen examples discovered include five dishes of North Italian and nine of the *sigillata Tardopadana* productions.

The Neronian period witnesses the appearance of completely new dish and cup forms of *sigillata Tardopadana* with a char-

acteristic barbotine decoration. Zabehlicky-Scheffenecker (1992, 416-417) defined them as formal group B. It is supposed that the *Tardopadana* potters here imitated the contemporary forms of Gaulish sigillata, though the relationship between the two productions has not as yet been fully explained. The 1<sup>st</sup> century saw only a limited scope of trade with Gaulish sigillata in the Po valley (Mazzeo Saracino 2000, 39). The formal group B completely asserts itself during the Flavian period, when its share equals that of the group A (with applied decoration). Later, however, it takes the upper hand. The production, or better said, use of the group B vessels and, with it, the entire *Tardopadana* production, terminated in the mid 2<sup>nd</sup> century (Zabehlicky-Scheffenecker 1992, 421-422).

Dishes and cups of the group B services share equally formed rims.<sup>12</sup> At Školarice, the most frequently represented service fragments of this group are those with the everted rim - the Consp. 39 dish (*Pl. 3: 12*) and the Consp. 43 cup (*Pl. 3: 9-11*). These also represent the leading form of the Flavian period in the Po valley and in the provinces of Noricum and Pannonia (Consp. 1990, 120, 128; Schindler-Kaudelka, Groh 1995, 360). A variant of the Consp. 43.2 cup with a low vertical edge on the inner side of the rim (Consp. 1990, 128) has also been recovered among the material (*Pl. 4: 1*).

The service with a horizontal rim with a raised edge that includes the dish of the Consp. 41 form (*Pl. 4: 4,5*) and the cup of the Consp. 45 form (*Pl. 4: 2*) is less frequent, since it is characteristic particularly for the western Po valley - Lombardy and Ticino (Consp. 1990, 124, 132; Zabehlicky-Scheffenecker 1992, 419).

A fragment of a dish with a horizontal rim is also preserved (*Pl. 4: 3*). It could belong to dishes with a curved wall profile of the Consp. 40 form or dishes with a straight wall profile of the Consp. 42 form, though the latter is extremely rare (Consp. 1990, 122, 126; Schindler-Kaudelka, Groh 1995, 360).

The fragmented state of preservation prevents a reconstruction of the scheme of the barbotine decoration. Only individual motifs are preserved: lily (*Pl. 3: 10*), ivy leaf on a branch (*Pl. 3: 12*), grape on a branch (*Pl. 4: 2*).

Vessels of the *sigillata Tardopadana* formal group C have not been recovered at Školarice.

The material revealed only three potter's stamps, one belonging to the North Italian B sigillata and two to *sigillata Tardopadana*, formal group A.

The base of a Consp. 3 dish (*Pl. 4: 11*) (less likely of the Consp. 4.6-7 form) has a *planta pedis* PHIL( ) stamp (OCK 1438.9). Such a stamp has been discovered on only one other dish, from Concordia (CVArr 1340), while other stamps that are equal in name but not in form, can be found elsewhere in the Mediterranean. We are probably dealing with several different potters that are attested to by a very limited number of finds. This renders the determination of the exact location and the dating of the workshops extremely difficult. The form of the stamp allows of only an approximate date after AD 15. The above-mentioned fragment could belong to North Italian sigillata B only conditionally, based on the size of the stamp which is much smaller than those on the *Tardopadana* products. The fabric of the fragment does not match those at Magdalensberg. The fragment might therefore belong to one of the smaller, more locally oriented workshops on the northern Adriatic coast.<sup>13</sup>

<sup>11</sup> The younger production of Italian sigillata in central Italy that succeeds Arretine sigillata and is contemporaneous with *sigillata Tardopadana* - second half of the 1st and first half of the 2nd centuries. For the definition of the term and the production see Consp. 1990, 13-16.

<sup>12</sup> The rim diameters vary between 6 and 27 cm. The artificial dividing line between cups and dishes with 6 cm of height and 15 cm of diameter is taken from Schindler-Kaudelka, Groh 1995, 360.

<sup>13</sup> Oral opinion of Zabehlicky-Scheffenecker after examining the fragment.

The stamps of *sigillata Tardopadana* have three initials stamped in a small footprint (*planta pedis*) frame - the *tria nomina* initials. The cup of the Consp. 29 form (*Pl. 4: 12*) has a C-T-P in *planta pedis* stamp (OCK 2027). This stamp was used in the Po valley to produce dishes of the Consp. 20.4 as well as cups of the Consp. 29 and 34 forms between the reigns of Claudius and Domitian (AD 30-80) at least, possibly even longer. The distribution area of these products covers the entire market of the *Tardopadana* production. The westernmost finds were recovered in Tortona and Locarno (CVArr 1886), that is in Liguria and the western Po valley. The easternmost examples were found at Sirmium (Brukner 1981, 54, 143, *Pl. 1: 26; 9: 7*) and Flavia Solva (Schindler-Kaudelka, Groh 1995, 361, *Pl. 24: 25,26*) and northernmost at Poetovio (CVArr 1886). The concentration of finds appears in the northern Adriatic, on the cemetery at Osor (Makjanić 1985, 43, *Pl. 3: 26*), in Aquileia and Morlun-go (CVArr 1886) as well as in Emona, where the stamp also appears on a cup of the same form (Petru 1972, grave 1347.1, *Pl. 117: 10*).

The third stamp (*fig. 4: 10*) on the base of the Consp. 34 cup is difficult to read - perhaps a C... or Q... *planta pedis* stamp.

Beside the plain North Italian sigillata, Školarice also revealed the North Italian relief-decorated sigillata (It. *terra sigillata norditalica decorata*), exclusively represented by two-handed Sarius cups. This sigillata represents only a 9.7% share of the sigillata ware or 14% share of the entire North Italian production (*Table 1* - values of the estimated minimum number of vessels). The production of the relief-decorated sigillata commences during the last quarter of the 1<sup>st</sup> century BC, is most popular during the first three decades of the 1<sup>st</sup> century AD, and terminates in the Claudian period (Schindler-Kaudelka 1980, 66; ead. 1998, 292; ead. 2000, 62). Its workshops were positively identified in Ravenna, Faenza, and Cremona. These were probably not the only ones, since many indications point to a great number of workshops, similarly to other North Italian productions (Schindler-Kaudelka 2000, 54). Its trading area corresponds to the distribution area of the plain North Italian sigillata (Kenrick 2000, 47-50).

The high state of fragmentation and absence of stamps at Školarice both render difficult the narrower determination into subgroups or individual workshops. Individual decorative motifs appear in various combinations, which, together with the small size of the fragments, renders impossible the reconstruction of the decorative scheme as well as the determination of production groups, that follows from it. Plant motifs include palmettes (*Pl. 5: 9,11*) and acanthus leaves (*Pl. 5: 2,6,8,10*), sometimes with a rosette or a bow (*Pl. 5: 6,8,10*). A set of relief circles frames the decorative field on the fragment on *Pl. 5: 12*. Only two fragments allow for a partial reconstruction of the decorative scheme. The decorative field on the fragment on *Pl. 5: 11* was probably divided by lines into triangular compartments or a mesh in the form of a star. The best preserved cup on *Pl. 5: 1* has a stylized column dividing the decorative field in rectangular compartments. The intermediary space is filled with a large kantharos and a stylized depiction of a soldier with a plumed helmet and a round shield. The poor fabric and manufacture quality, exhibited by most of the examples, indicates the youngest phase of production (Brusić 1999, 28; Schindler-Kaudelka 2000, 53-54).

#### EASTERN SIGILLATA

Fragments of eastern sigillata B, more precisely its later phase B2, represent a significant portion of the sigillata ware. Eastern sigillata B2 ware is characterized by porous clay rich in mica as

well as a matt and soapy orange slip (Hayes 1985, 51). The strong presence of eastern B1 and B2 sigillatas<sup>14</sup> in Ephesus and Priene points to their origin in western Asia Minor (Hayes 1985, 49), a supposition confirmed by chemical and mineralogical analyses. Equal contents of heavy minerals are, in fact, only found in the clay in the vicinity of ancient Tralles (modern Aydin), 50 km off the coast (Schneider 2000b, 532). Pottery workshops of this city must have been of some importance, since they are mentioned by Pliny the Elder (Hayes 1985, 49).

Eastern sigillata B1 was under the strong influence of Italian sigillata. This is visible in forms and in stamps with potter's names. It is dated to the period from the beginning to the third quarter of the 1<sup>st</sup> century AD and is spread mostly across the Aegean basin. The transitional phase B1/2 (third quarter of the 1<sup>st</sup> century) already witnessed the development of the characteristic forms of eastern sigillata B2 that turn away from Italian models. The production now focuses on a few standard forms, the vessel size gradually increases, and potter's stamps are replaced by stylized stamps of rosettes and palmettes. Despite a considerable fall in quality, caused by a softer fabric and a thicker slip, its distribution, nevertheless, witnesses a strong increase (Hayes 1985, 49-52).

Examples of eastern sigillata B1 appear only sporadically. Eastern sigillata B2, on the other hand, is documented with a high number both on land and underwater sites (Jurišić 2000, 33-34).

A very revealing ship wreck with its cargo was discovered just off the cape of Izmetište in the archipelago of Pakleni otoci, central Dalmatia. This merchant ship from the first half of the 2<sup>nd</sup> century carried mixed cargo: nine large limestone semi-products and one made of green granite, several Greek Koan amphorae Dr. 2-4, and a large quantity (over 3000 examples) of pottery - eastern sigillata B2 and eastern cooking ware (Jurišić 2000, 65). The ship sailed along the main maritime route along the eastern Adriatic coast from Greece or Asia Minor towards the important northern Adriatic ports - Aquileia and Ravenna or other major cities in Istria and Dalmatia.

Eastern sigillata B2 at Školarice constitutes approximately 25% of the entire sigillata ware of the 1<sup>st</sup> and 2<sup>nd</sup> centuries (*Table 1*). Best represented are fragments of biconical dishes with a flat base of the Hayes 60 form (*Pl. 6: 1-5*) and fragments of Hayes 80 cups (*Pl. 6: 6-10*). The Hayes 60 dishes were produced already during the transitional B1/2 phase, from AD 50/60-80/90. Smaller examples with emphasized low triangular rims gradually developed into large dishes with simplified rims and characteristic hammer-head rim mouldings (Hayes 1985, 64). This leading form of eastern sigillata B2 is very frequent along the Adriatic coast and elsewhere across the Mediterranean. The above-mentioned Izmetište wreck revealed Hayes 60 dishes in their original position, indicating the manner in which pottery was laid and loaded onto a ship with dishes being laid in sets, always with smaller into larger ones. There was also a Hayes 80 cup found in a Hayes 60 dish, possibly indicating a service (Jurišić 2000, 32-33). The production of these cups began after the destruction of Pompeii - around AD 80 (Hayes 1985, 69).

The Školarice material treated here reveals only younger examples of Hayes 60 dishes that are contemporaneous with the Hayes 80 cups. In Ephesus, on the other hand, the use of these dishes continues during the entire second half of the 2<sup>nd</sup> and the first half of the 3<sup>rd</sup> centuries (Gassner 1997, 127).

Dishes with an everted and bent rim of the Hayes 62 form (*Pl. 7: 1,2*) constitute a service with a cup of the same rim moulding, form Hayes 74 (*Pl. 7: 3-7*). Both forms are dated, on the basis of stylized stamps in the form of rosettes and palmettes, particularly into the Flavian and Trajanic periods - AD

<sup>14</sup> For the definition of eastern sigillatas B1 and B2 see Hayes 1985.

70/75-120. Variants of the Hayes 62B dishes (*Pl.* 7: 2) and the Hayes 74B cups (not present at Školarice), with a characteristic rouletted decoration of the exterior surface of the rim, are relatively rare (Hayes 1985, 65, 68).

A contemporary of the service, constituted by the dish of the Hayes 62 and the cup of the Hayes 74 forms, is the service with the everted rim that includes the dish of the Hayes 63 form (*Pl.* 7: 9) and the cup of the Hayes 75 form (*Pl.* 7: 8). Their similarities in production, form, and stamps led Jurišič to go as far as to join them into common forms 62/63 and 74/75. He then determined the variant A with a simpler profile of the everted rim (forms Hayes 63 and 75) and the variant B with the more complex profile with the forms Hayes 62 and 74 (Jurišič 2000, 33).

The Školarice material also includes a cup with a slightly everted rim of the Hayes 76 form, both its smaller and earlier variant A (*Pl.* 7: 10,11), characteristic particularly of the transitional B1/2 and the early B2 phases, as well as the larger and younger variant B (*Pl.* 7: 12,13), discovered also among the cargo onboard the Izmetišče wreck (Jurišič 2000, 32). Most frequent variants of these cups across the Mediterranean are the largest and youngest ones (Hayes 1985, 68-69).

The base fragment on *Pl.* 7: 15 probably belongs to a wider dish of the Hayes 77 form which is a rare form and appears during the first half of the 2<sup>nd</sup> century (Hayes 1985, 69).

Stamps in the form of rosettes or palmettes on the bases of cups or dishes appear in the Flavian and Trajanic periods (Hayes 1985, 52). The base of a Hayes 76B cup (*Pl.* 7: 13) has a stamped palmette and the base of a cup of the Hayes 71 form or a smaller dish of the Hayes 60 form (*Pl.* 7: 14) bears a rosette. For the vessels of the eastern sigillata B2 production in the second quarter of the 2<sup>nd</sup> century stamped decoration was no longer in use.

The most frequent form at Školarice is the Hayes 60 dish, followed by Hayes 80 and Hayes 76 cups, services of the Hayes 62 and 74 as well as Hayes 63 and 75 forms. Other forms appear only sporadically. The entire spectrum of the Izmetišče wreck cargo is thereby represented, well illustrating the import of eastern sigillata B2 into the Adriatic.

Eastern sigillata B is present at important Adriatic ports of Salona (Jurišič 2000, 34), Narona (Topić 2003, 192), Ravenna (Maioli 1990, 422), and Aquileia (Ventura 1991; ead. 1994; Mandruzzato, Tiussi, Degrassi 2000, 361), in the Istrian cities of Pola (Matijašič 1991; Maggi, Starac 2000) and Tergeste (Maselli Scotti 1987) as well as the inland site of Emona (Petru 1972, 70, grave 778, *Pl.* 50: 30). Many examples were recovered in the Quarnero bay (Makjanič 1983, 52). The cemetery of Bakar revealed eastern sigillata B in the graves from the Neronian to the Antonine periods; in the youngest grave context it was found accompanied by a coin of Faustina the Elder (Makjanič 1983, 52).

Eastern sigillata was also found in Istrian villas at Loron (Maggi, Starac 2000; Maggi 2001, 152-153) and Brijuni (Maggi, Starac 2000; Vidrih Perko, Pavletić 2000, 263-264). A younger Hayes 60 dish was found during the excavation of a villa in the bay of Simonov zaliv (Mikl Curk 1996, 252, Fig. 8), at nearby Štramar (Maselli Scotti 1997, 70, *Pl.* 10: 23) and at villa Joannis in the ager of Aquileia (Strazzula Rusconi 1979, 42).

Mass export from Asia Minor to the Adriatic area should be delimited with the mid 2<sup>nd</sup> century. Recent research has shown that the production of eastern sigillata B did not cease in the mid 2<sup>nd</sup> century, as had been supposed by Hayes (1985, 51), and that, in fact, its presence continued in Ephesus and other cities of the south western coast of Asia Minor in later layers as well, until the first half of the 3<sup>rd</sup> century (Gassner

1997, 127). In Corinth, for example, it dominates the fine ware throughout the 2<sup>nd</sup> century (Slane 2000, 307). Though in smaller numbers, it should nevertheless be expected in a similar time span on the Adriatic coast as well, particularly the Hayes 60 dishes (Vidrih Perko, Pavletić 2000, 264), since the expansion of the imported African red slip ware does not occur until somewhat later (Pröttel 1996; Biondani 1992).

## CONCLUSION

The sigillata ware, treated here, exhibits the eating habits of the Školarice villa's inhabitants during the 1<sup>st</sup> and the 2<sup>nd</sup> centuries, who completely embraced the Italian way of life and their eating habits as well. The material's importance also lies in its contribution to the dating of the villa's beginning and complementing the knowledge of pottery trade across the northern Adriatic during the 1<sup>st</sup> and the 2<sup>nd</sup> centuries.

The fragmented state and dispersion of the sigillata prevent us from precisely dating the construction of the complex without previously analysing the entire body of finds. There are, however, certain preliminary conclusions that can be made.

The evidence presented in this article allows for the beginning of the villa to be dated approximately to the second quarter or the middle of the 1<sup>st</sup> century. This date is suggested by the few recovered fragments of Arretine and North Italian relief-decorated sigillatas, the productions of which end during the mid 1<sup>st</sup> century. The absence of the black-slip pottery as well as the minimal presence of the Venetic gray pottery are also significant, since they sporadically still appear in the northern Adriatic during the first half of the century (Stokin 1990; Buora 2001; Merlatti 2003, 7). Although some of the recovered forms of Arretine (Consp. 22.1 - *Pl.* 1: 1) and North Italian sigillatas (Consp. 22.6 - *Pl.* 1: 9, partly Consp. 18.2 - *Pl.* 1: 7,8) are chronologically delimited with the first quarter of the 1<sup>st</sup> century, their paucity, nevertheless, speaks against pushing the villa's construction backwards, into the production time of the sigillatas. The explanation for their appearance is rather one of residual<sup>15</sup> or long-term use, which could also hold true for the rare contemporary coin finds - an *as* from the reign of Tiberius (AD 15-16), for example.<sup>16</sup>

The early period of the villa shows an almost complete predominance of the sigillata of the strong North Italian production (*Table 1*). A small share of sigillata is supposed to be produced also by workshops of a local or regional character. At Školarice and across the northern Adriatic only a small fraction of fragments belong to the Arretine production. Makjanič showed (1989, 61), by comparing the shares of the Arretine and the North Italian stamps, that the presence of the latter is up to six or seven times higher than that of the Arretine production in the *Regio X* and the Quarnero bay while in Pannonia their shares are almost equal. The intermediary role of Aquileia as the main distribution centre for trade with Pannonia can also be seen in the weak predominance of North Italian over Arretine sigillata in this city (ead. 61). The inhabitants of the northern Adriatic settlements were delivered Arretine sigillata via Aquileia or by a direct link between the west Adriatic coast - Rimini, Adria in Ravenna - with the coastal cities of Istria (Maggi 2001, 149, 158).

The high share of the North Italian relief-decorated sigillata would also go to confirm the beginning of the villa as early as the first half of the 1<sup>st</sup> century, in the Claudian period.

The most frequent fragments of the North Italian production are those of *sigillata Tardopadana*. This is not surprising,

<sup>15</sup> The beginning phase prior to the construction of the complex, which is stratigraphically poorly preserved, would be possible (Trenz et al. 2002).

<sup>16</sup> Coin finds were determined by the Coin Cabinet at the National Museum of Slovenia.

since the span of its production fits, from beginning to end, into the life-span of the villa, which is not the case with North Italian sigillata. The production of the latter probably does not cease during the Claudian period, but somewhat later. The most numerous forms of Italian sigillata at Školarice are those "common" to both the North-Italian and the *Tardopadana* productions (formal group A). These predominate on other sites mostly in the contexts of the mid 1<sup>st</sup> century. Beside them, the Roman tables were laid with completely new forms during the Neronian and the Flavian periods - the *Tardopadana* services of the formal group B.

The import of eastern sigillata B2 from far-away cities of Asia Minor commences in the last quarter of the 1<sup>st</sup> century. This sigillata is unusually frequent at Školarice (approximately 25%), particularly if only the 1<sup>st</sup> and 2<sup>nd</sup> centuries sigillata is considered. Unfortunately, the high degree of homogeneity of sigillata *Tardopadana* throughout its production prevents a comparison of the variations in the relationship between *Tardopadana* and eastern sigillatas. The comparison between the formal groups A and B of the *Tardopadana* production shows a lower share of group B. This can only be explained by supposing that, during the first half of the 2<sup>nd</sup> century, when the formal group B of sigillata *Tardopadana* elsewhere predominates over group A (Zabehlicky-Scheffenegger 1992, 421-422; Schindler-Kaudelka, Fastner, Gruber 2001, 153), the eastern sigillata B2 nevertheless strongly establishes itself on the tables of the inhabitants at Školarice.

Although eastern sigillata B appears on numerous Adriatic sites, the data obtained at Školarice can only be compared to a few of them. At the sites of Quarnero bay (Reka, Omišalj, Krk, and Osor), the share of eastern sigillatas B1 and B2 represent approximately 14% of the sigillata ware. The necropolis of Bakar stands out, since its share of eastern sigillata increases to a staggering 52.17% (Makjanić 1983, 51-52).<sup>17</sup> A high share of eastern sigillata can also be observed in Kastrum on the Brijuni Islands, where the quantity of eastern sigillata is only a third lower than that of the entire Italian sigillata (Vidrih Perko, Pavletić 2000, 267, fig. 1).<sup>18</sup> The share at the Loron villa is surprising, since there is only 4% of eastern sigillata among the entire sigillata ware. These are most likely chronological nuances, since the stratigraphic contexts presented are those of the 1<sup>st</sup> and the beginning of the 2<sup>nd</sup> century, the period in which the Italian and North Italian workshops - one of which is also the workshop at Loron - prospered most (Maggi, Starac 2000, 356; Maggi 2001, 152). These layers are therefore relatively early compared to the rise in the import of eastern sigillata to the northern Adriatic. This difference is probably also attributable to the fact that it is the productional part of the villa, since at Školarice as well very little sigillata was found in what is considered as the production area.

At the Brijuni and Loron sites there is only an insignificant share of the *Tardopadana* formal group B (Maggi 2001, 147; Vidrih Perko, Pavletić 2000, 263), while its complete absence

can be observed at the sites of Osor, Krk, Omišalj, Reka, and Bakar in the Quarnero bay (Makjanić 1987, 231). This only confirms the suppositions as to the predominance of eastern sigillata B2 during the first half of the 2<sup>nd</sup> century on the north-eastern coast of the Adriatic which spread at the expense of sigillata *Tardopadana*, more precisely its formal group B.

A very high, 60-70%, share of eastern sigillata<sup>19</sup> was observed also in Tergeste, during the excavations conducted behind the Roman theatre. This led Maselli Scotti (1987, 217-220) to the assumption that the trade with the East (the reflection of which is a strong presence of eastern sigillata) could have been carried out directly from Tergeste, avoiding altogether the main port of the region - Aquileia. This would furthermore be confirmed by the paucity of eastern sigillata in the latter city (ead. 219). Although the eastern part of the Aquileian forum indeed yielded only a small amount of eastern sigillata (Ventura 1991; ead. 1994), I am, nevertheless, of the opinion that Aquileia cannot as yet be ruled out as a possible main trade centre for eastern sigillata. Only recently have the re-examinations of the vast museum storage areas of Aquileia<sup>20</sup> begun to yield material imported from the Aegean and the eastern Mediterranean areas (amphorae, lamps, Aegean cooking pottery) from the 1<sup>st</sup> century AD onwards (Mandrizzato, Tiussi, Degrassi 2000). Eastern sigillata was, as any other type of pottery, a trade good secondary in nature. Ships from the eastern Mediterranean brought to the northern Adriatic mostly the much appreciated Aegean wine, transported in Aegean variants of amphorae Dr. 2-4, in Rhodian Imperial, and Cretan amphorae (Jurišić 2000, 58).

The import of eastern sigillata B2 probably gradually ceases during the second half of the 2<sup>nd</sup> century. At the end of the 2<sup>nd</sup> century the Roman tables welcomed new sets of vessels of African sigillata, which went on to predominate throughout the late Antiquity (Pröttel 1996; Biondani 1992).

The main trade centre for the northern Adriatic area was Aquileia (Tassaux 2004), where the merchandise from the eastern Mediterranean gathered, brought by large sea-faring ships. Part of this trade could also have been conducted at Tergeste. From both cities - but more so from Aquileia - the merchandise then travelled by road towards the Alpine and the Danubian regions, by river up the Po valley, and with smaller vessels by sea to other northern Adriatic or Istrian cities, settlements, and villas, which themselves often acted as smaller distribution centres for their surroundings.

Tina Žerjal  
Inštitut za arheologijo  
Znanstveno raziskovalnega centra SAZU  
Novi trg 2  
SI-1000 Ljubljana  
tina.zerjal@zrc-sazu.si

<sup>17</sup> The data for Osor and Bakar come from the necropoles of the 1st and 2nd centuries, for others the chronological scope of the material is not known (Makjanić 1983; ead. 1985).

<sup>18</sup> Although the values on the chart apply to the entire pottery of the site, only the data for the Italian (the text only mentions the North Italian production: North Italian sigillata, Sarius cups, Aco beakers, and sigillata *Tardopadana*) and eastern sigillatas (supposedly only eastern sigillata B is counted) were compared.

<sup>19</sup> The few examples of eastern sigillata A and Phocaeen sigillatas are also included.

<sup>20</sup> For citations on large quantities of eastern sigillata in museum storage areas of Aquileia, see Strazzula Rusconi 1979, 42.

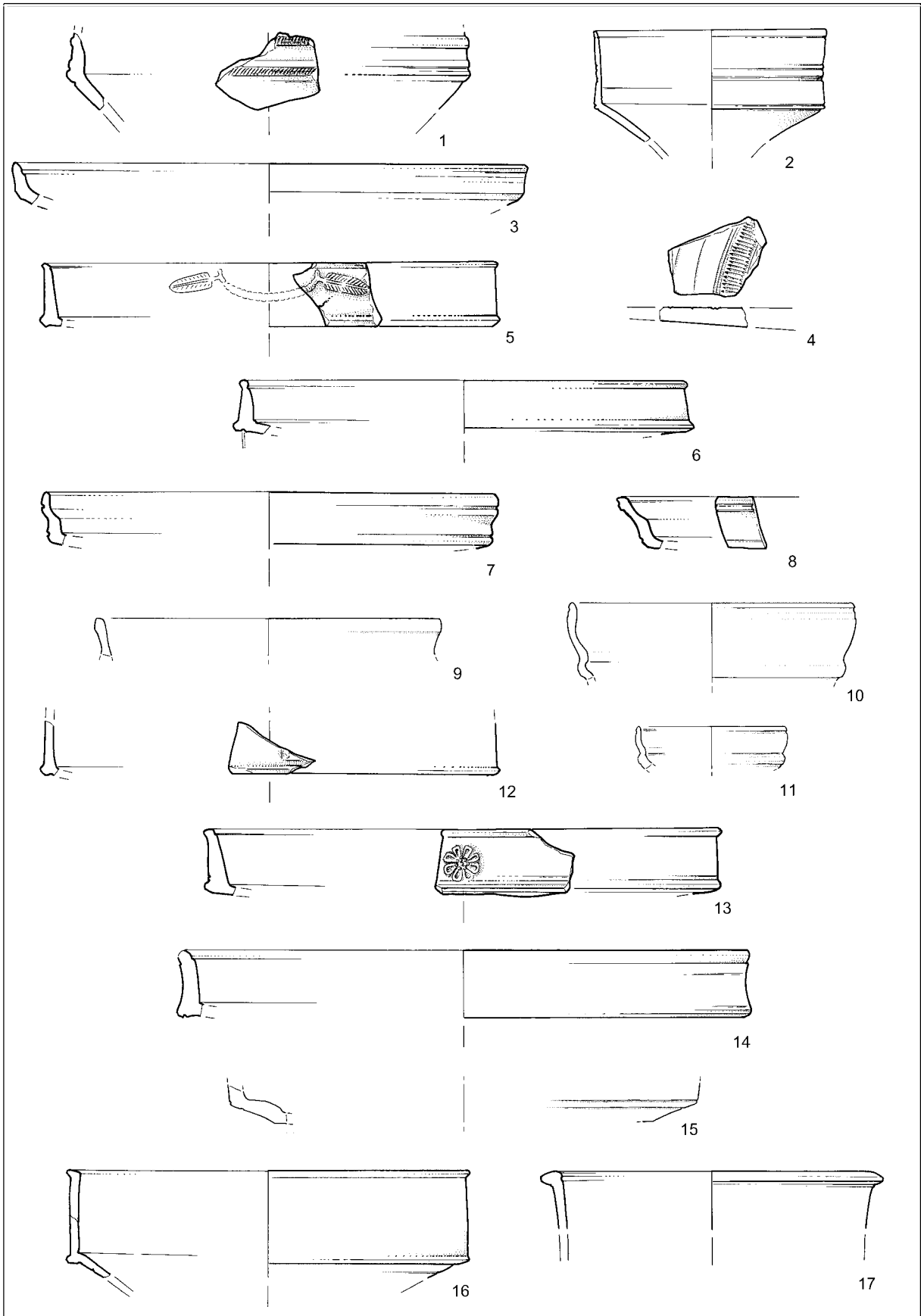

T. 1: Školarice. Aretinska, padška in poznopadska sigillata. Keramika. M. = 1:2.

Pl. 1: Školarice. Arretine sigillata, North Italian sigillata and *sigillata Tardopadana*. Pottery. Scale = 1:2.



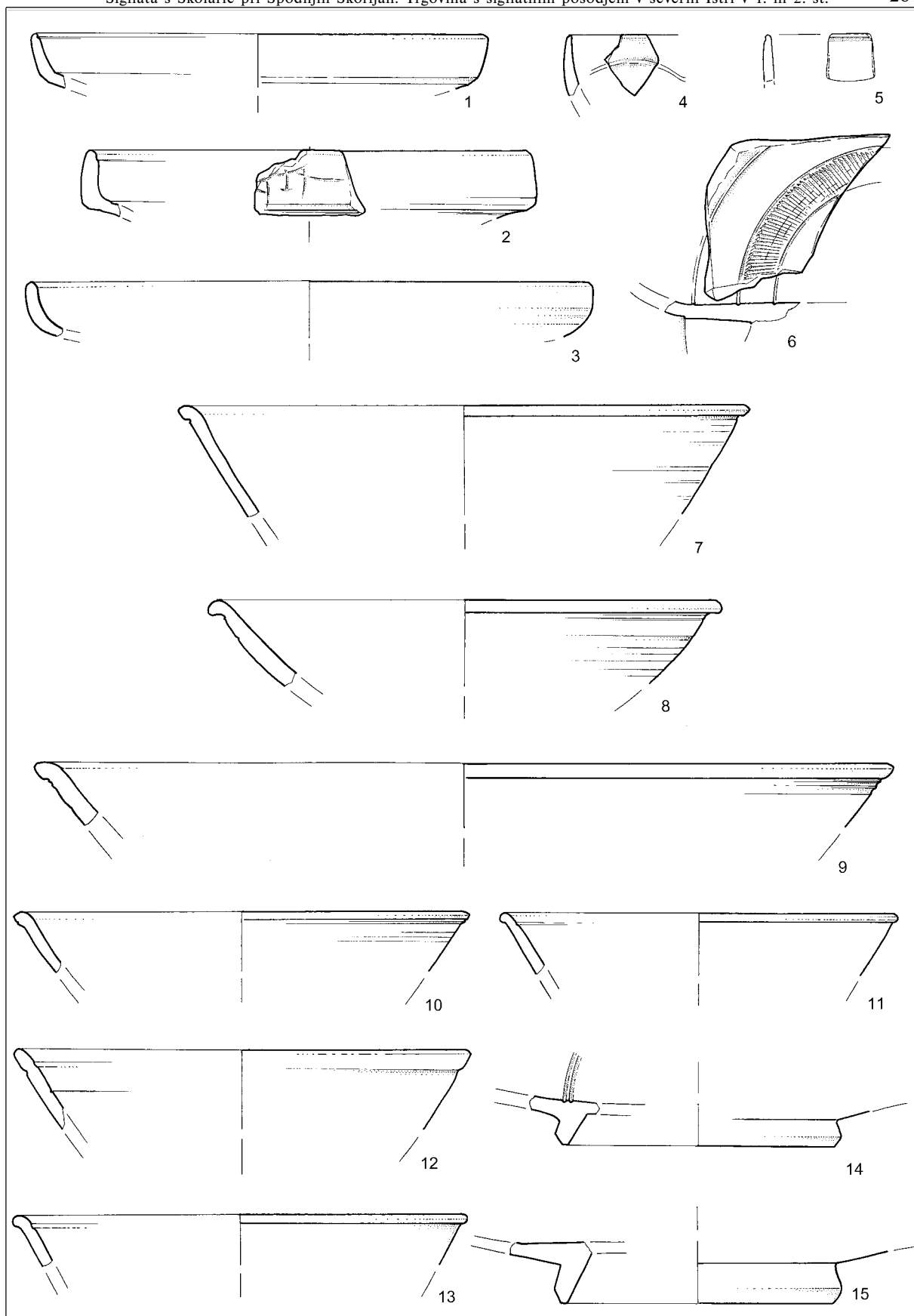

T. 2: Školarice. Padska in poznopadska sigilata. Keramika. M. = 1:2.

Pl. 2: Školarice. North Italian sigillata and sigillata Tardopadana. Pottery. Scale = 1:2.

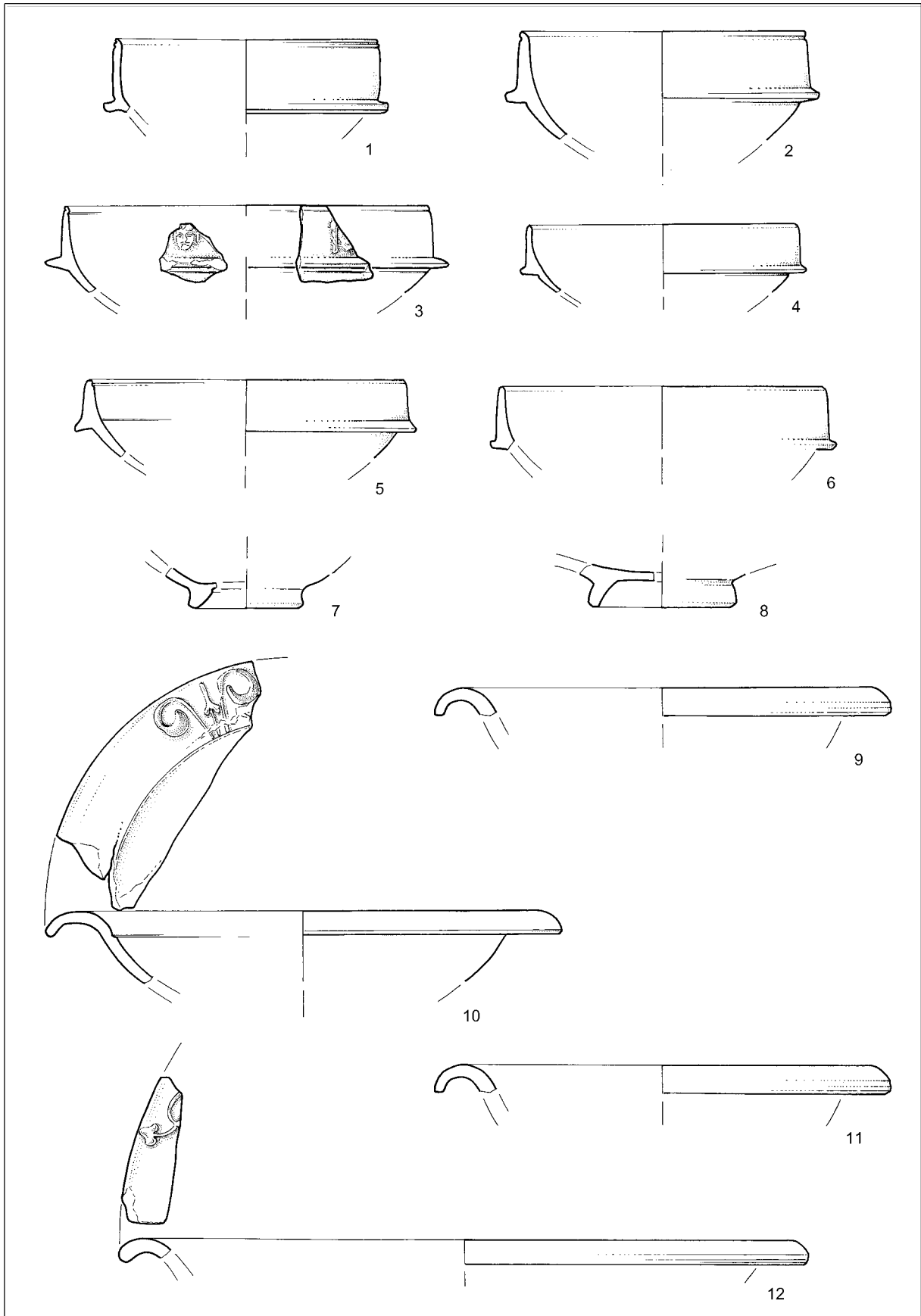

T. 3: Školarice. Padska in poznopadska sigilata. Keramika. M. = 1:2.

Pl. 3: Školarice. North Italian sigillata and sigillata Tardopadana. Pottery. Scale = 1:2.

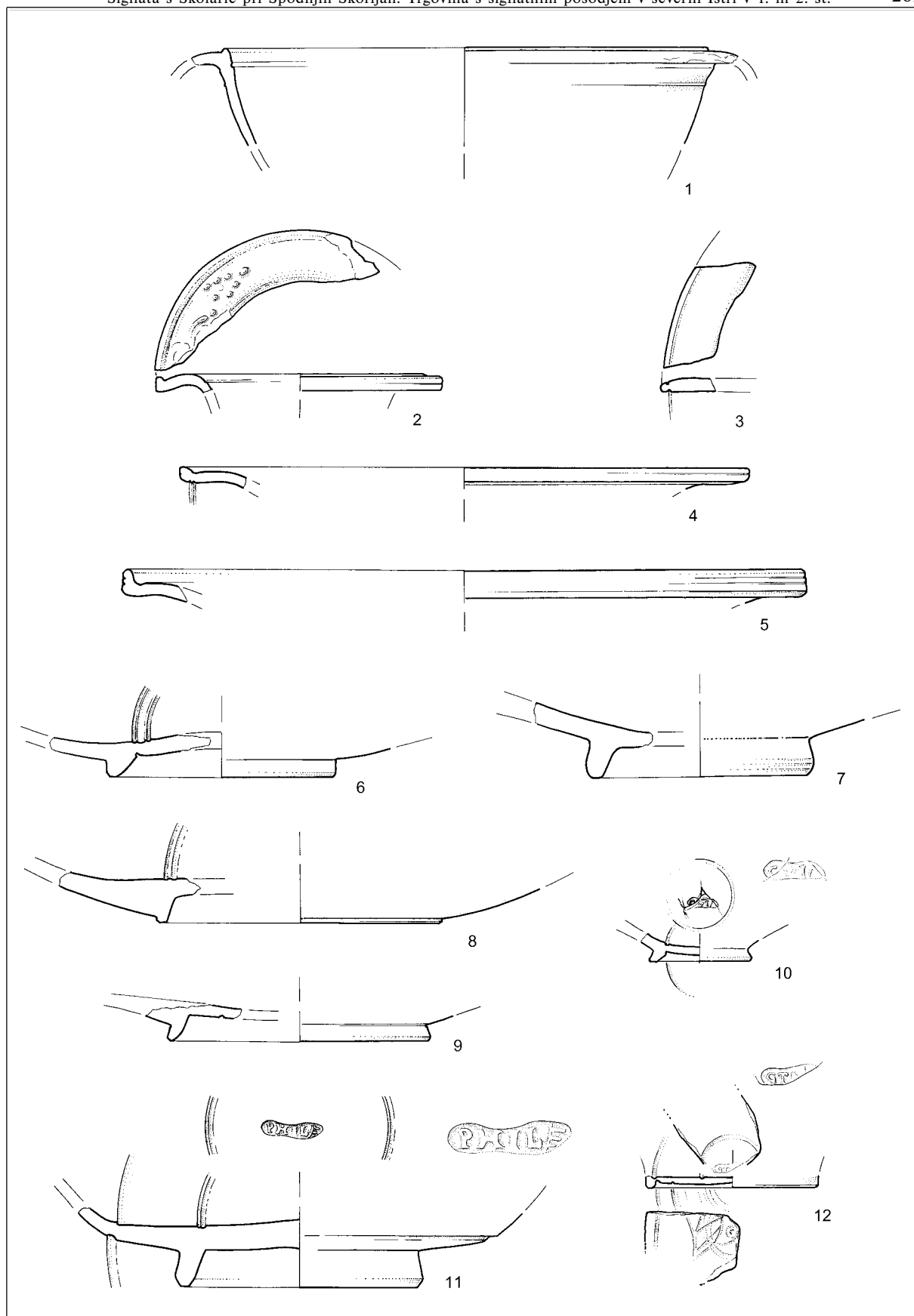

T. 4: Školarice. Padska in poznopadska sigilata. Keramika. M. = 1:2.

Pl. 4: Školarice. North Italian sigillata and sigillata Tardopadana. Pottery. Scale = 1:2

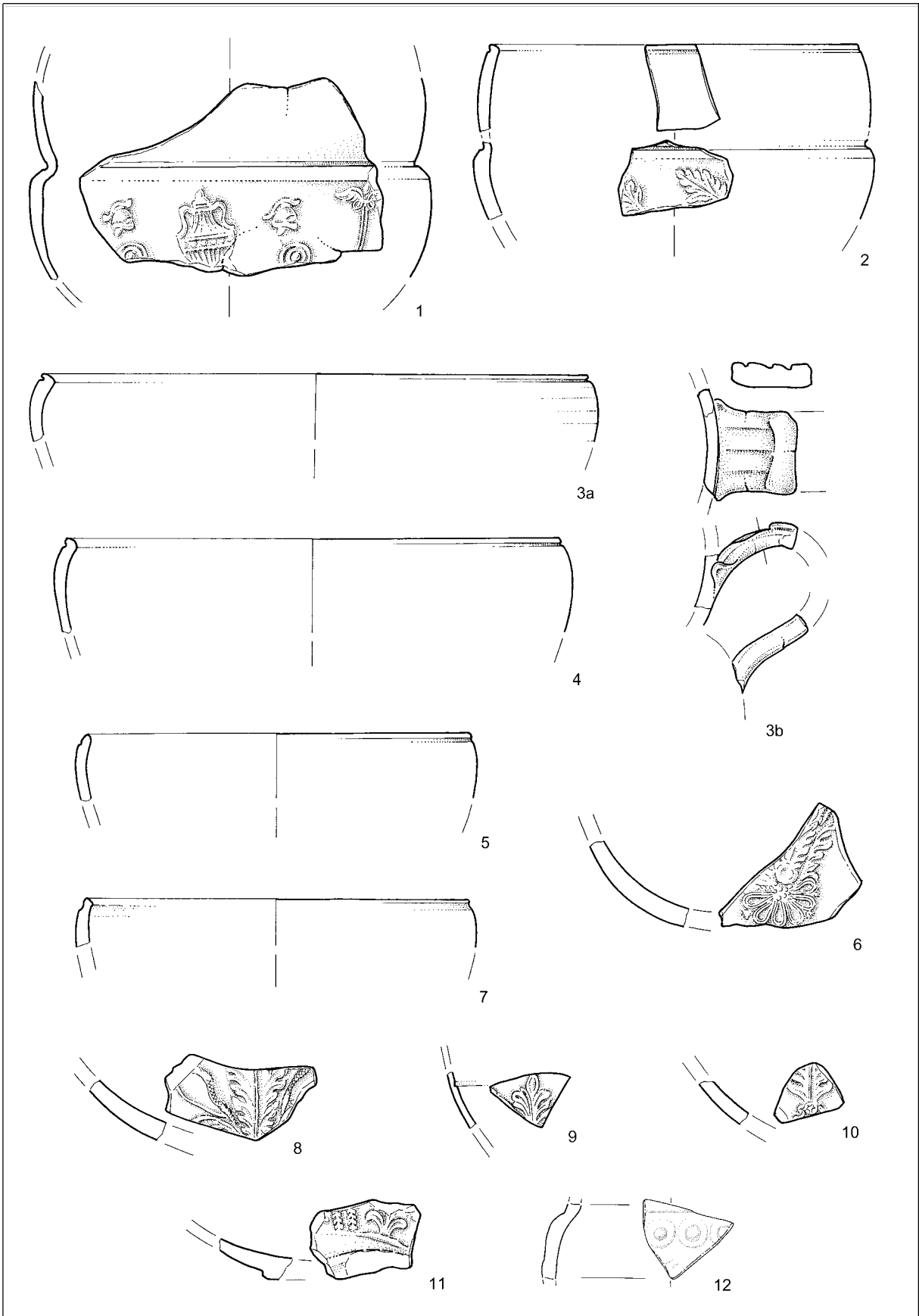

T. 5: Školarice. Severnoitalska reliefna sigilata. Keramika. M. = 1:2.

Pl. 5: Školarice. North Italian relief-decorated sigillata. Pottery. Scale = 1:2.

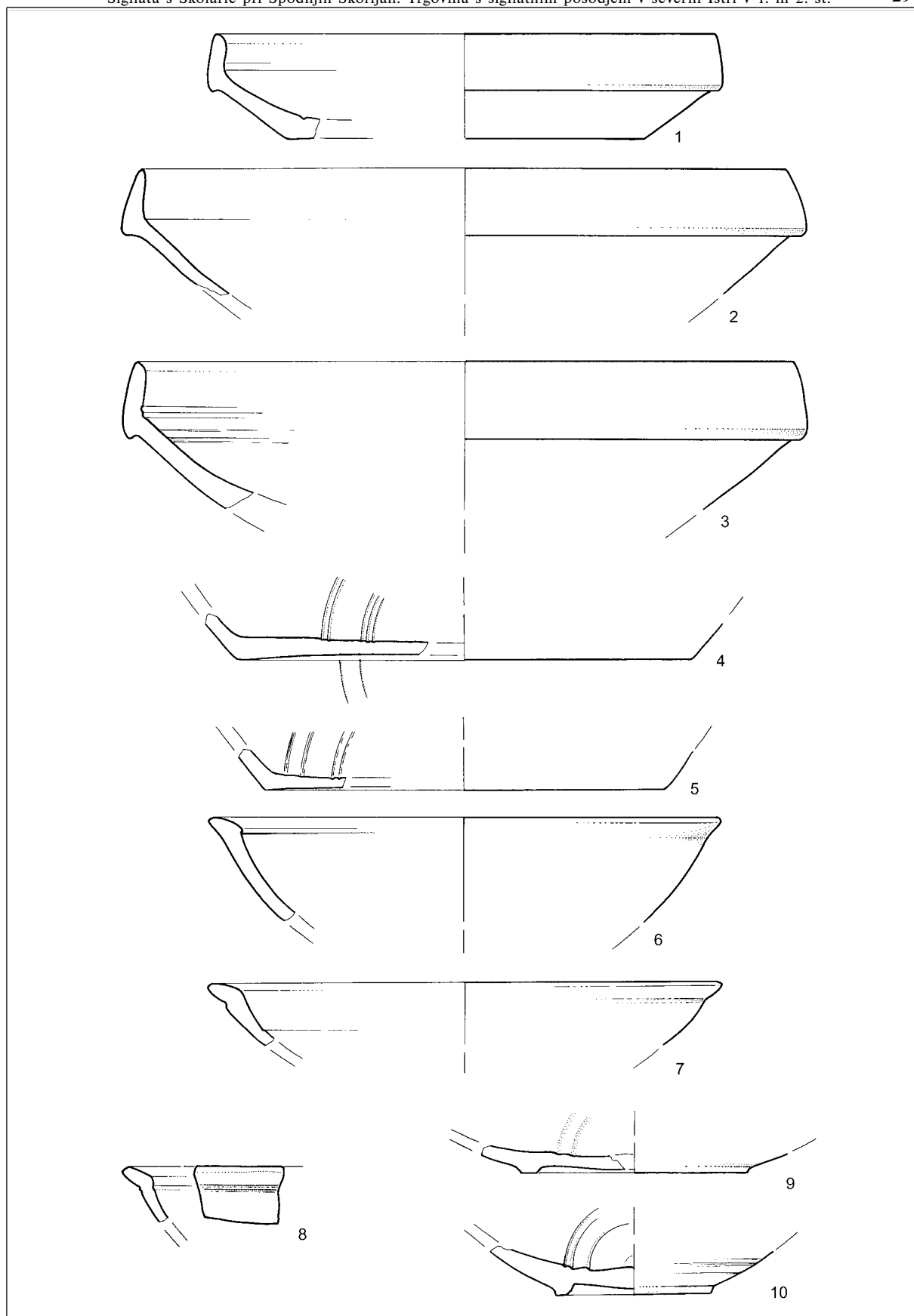

T. 6: Školarice. Vzhodna sigilata B2. Keramika. M. = 1:2.  
 Pl. 6: Školarice. Eastern sigillata B2. Pottery. Scale = 1:2.

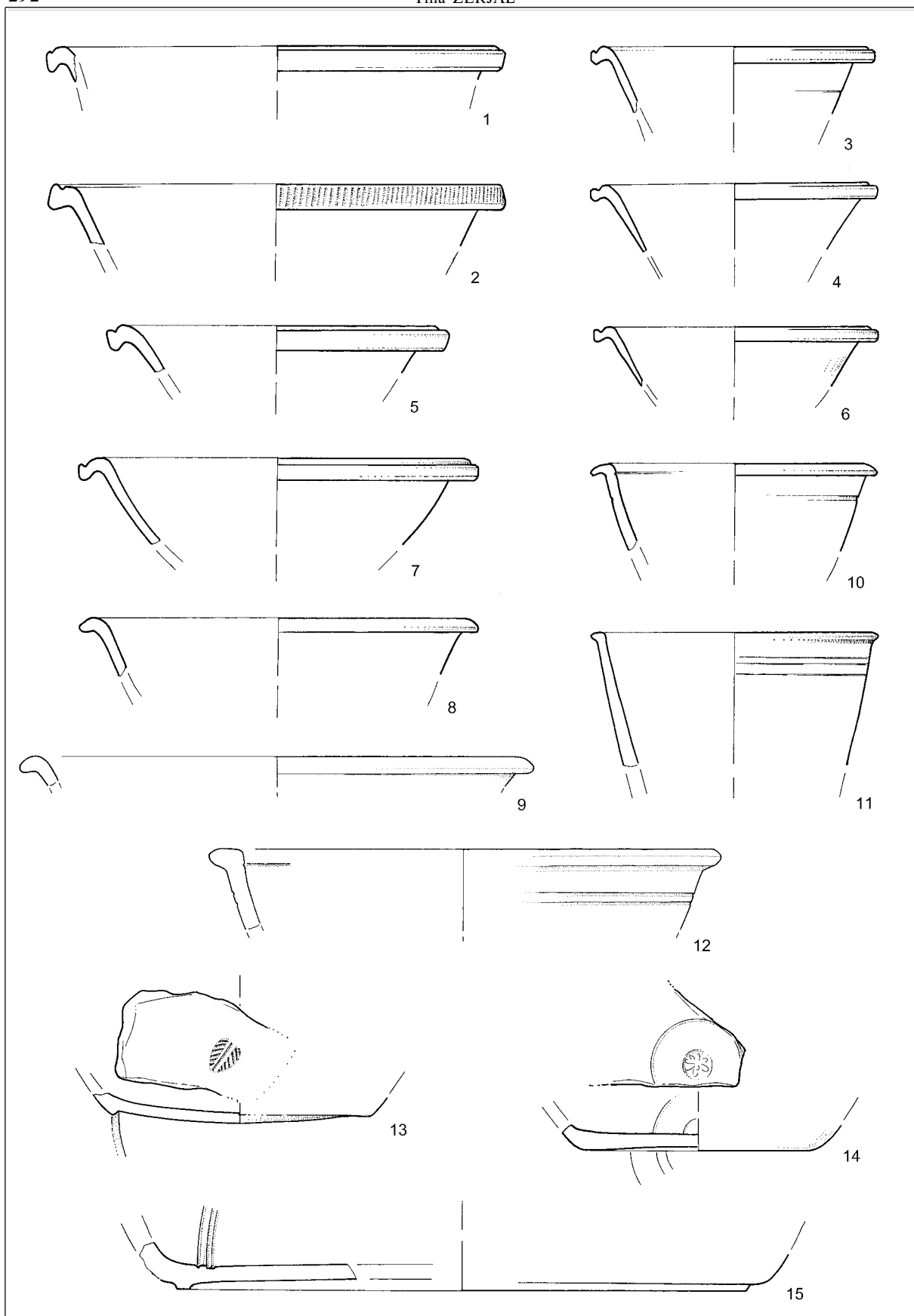

T. 7: Školarice. Vzhodna sigilata B2. Keramika. M. = 1:2.  
 Pl. 7: Školarice. Eastern sigillata B2. Pottery. Scale = 1:2.