

# EXPERIMENTAL VERIFICATION OF THE NUMERICALLY DETERMINED PARAM- ETERS FOR THE NON-LINEAR TWO-AXIS MODEL OF A SYNCHRONOUS MOTOR WITH INTERIOR PERMANENT MAGNETS

## EKSPERIMENTALNO PREVERJANJE NUMERIČNO DOLOČENIH PARAME- TROV ZA NELINEARNI DVOOSNI MODEL SINHRONSKEGA MOTORJA Z NOTRANJIMI TRAJNIMI MAGNETI

Željko Hederić<sup>‡</sup>, Venco Ćorluka<sup>1</sup>, Toni Varga<sup>1</sup>

**Keywords:** synchronous motor, flux linkage, interior permanent magnets, non-linear

### Abstract

Synchronous machines belong to the family of electrical machines characterised by a synchronous magnetic rotating field in the air gap of the machine, the speed of which depends on the frequency of the currents in the armature winding. The paper presents procedures and methods for the numerical determination and experimental verification of the parameters for a nonlinear two-axis model of a synchronous motor with permanent magnets in the rotor (IPMSM) and a concentrated stator winding. To calculate the distribution of electro-magnetic fields in the motor accurately, models with

<sup>‡</sup> Prof.Dr.Sc. Željko Hederić, PhD, Faculty of Electrical Engineering, Computer Science and Information Technology Osijek, Kneza Trpimira 2B, HR-31000 Osijek, Croatia, +385 31 224 600, [zeljko.hederic@ferit.hr](mailto:zeljko.hederic@ferit.hr)

<sup>1</sup> University of Osijek, Faculty of Electrical Engineering, Computer Science and Information Technology Osijek, Kneza Trpimira 2B, HR-31000 Osijek, Croatia

distributed parameters are used in motor design, for which the Finite Element Method (FEM) is usually employed. The improvement by using the model with concentrated parameters considerably simplifies the physical model, by describing it with a system of (non)linear differential equations, the so-called partial differential equations, which is presented in this paper.

## **Povzetek**

Sinhronski stroji spadajo v družino električnih strojev, za katere je značilno sinhrono magnetno vrtljivo polje v zračni reži stroja, katerega hitrost je odvisna od frekvence tokov navitja armature. V prispevku so predstavljeni postopki in metode za numerično določanje in eksperimentalno preverjanje parametrov za nelinearni dvoosni model sinhronskega motorja s trajnimi magneti v rotorju (IPMSM) in koncentriranim statorskim navitjem. Pri načrtovanju motorjev se za natančnejši izračun porazdelitve elektromagnetnih polj v motorju uporabljajo modeli s porazdeljenimi parametri, za kar se običajno uporablja metoda končnih elementov (MKE). V prispevku je predstavljena izboljšava, ki z uporabo modela s koncentriranimi parametri v osnovi znatno poenostavi fizični model, tako da ga opiše s sistemom (ne)linearnih diferencialnih enačb, tako imenovanih delnih diferencialnih enačb.

## **1 INTRODUCTION**

A synchronous motor with interior permanent magnets and concentrated winding (IPMSM) has 12 stator slots and 10 magnetic poles inside the rotor. The motor has an uneven air gap. The mathematical modelling starts with setting up the voltage equations for each winding in a three-phase system [1, 2]:

$$u_{abc} = Ri_{abc} + \frac{d}{dt}\Psi_{abc} + \frac{d}{dt}\Psi_{mabc} \quad (1.1)$$

The contributions of a flux linkage from a permanent magnet are represented by  $\Psi_{mabc}$  in a three-phase system of motor supply. By converting a three-phase time system into a two-axis position system, one obtains the voltage equation for a magnetically nonlinear dynamic model of a synchronous motor with permanent magnets in a d-q system:

$$\begin{bmatrix} u_d \\ u_q \end{bmatrix} = R \begin{bmatrix} i_d \\ i_q \end{bmatrix} + \mathbf{M}_1 \cdot \frac{d}{dt} \begin{bmatrix} i_d \\ i_q \end{bmatrix} + \frac{d\theta}{dt} \cdot \mathbf{M}_2 \quad (1.2)$$

where  $\mathbf{M}_1$  and  $\mathbf{M}_2$  are the system matrices:

$$\mathbf{M}_1 = \begin{bmatrix} \frac{\partial \psi_d}{\partial i_d} & \frac{\partial \psi_d}{\partial i_q} \\ \frac{\partial \psi_q}{\partial i_d} & \frac{\partial \psi_q}{\partial i_q} \end{bmatrix} \quad (1.3)$$

$$\mathbf{M}_2 = \begin{bmatrix} \frac{\partial \psi_d}{\partial \theta} \\ \frac{\partial \psi_q}{\partial \theta} \end{bmatrix} + \begin{bmatrix} -\psi_q \\ \psi_d \end{bmatrix} + \begin{bmatrix} \frac{\partial \psi_{md}}{\partial \theta} \\ \frac{\partial \psi_{mq}}{\partial \theta} \end{bmatrix} + \begin{bmatrix} -\psi_{mq} \\ \psi_{md} \end{bmatrix} \quad (1.4)$$

The partial derivatives within the matrices, as well as the flux linkage of the stator ( $\Psi_d, \Psi_q$ ) and the flux linkage of the permanent magnets ( $\Psi_{mq}, \Psi_{md}$ ), represent the parameters of the model which must be determined experimentally due to their nonlinearity. The magnetic fluxes of the stator depend on the currents and position of the rotor, while the magnetic fluxes of the permanent magnet depend only on the position of the rotor.

## 2 DETERMINING NONLINEAR PARAMETERS BY THE FINITE ELEMENT METHOD

The magnetic nonlinear parameters required for the flux linkages and their partial derivatives can be determined with the Finite Element Method (FEM) (or the distributed parameter model), or experimentally. The input variables are the stator current parameters  $i_d, i_q$  and the rotor position  $\theta$ . Flux linkages are obtained by solving the Poisson's equation via the vector of magnetic potential [2, 3]:

$$\frac{\partial^2 \mathbf{A}}{\partial x^2} + \frac{\partial^2 \mathbf{A}}{\partial y^2} = -\mu \mathbf{J} \quad (2.1)$$

The relation between the magnetic flux and the vector of the magnetic potential according to Stokes' theorem is:

$$\Phi^e = \oint_C \mathbf{A}^e d\mathbf{l}^e \quad (2.2)$$

The magnetic flux  $\Phi_s$  for one winding is equal to the difference between the magnetic potential of the left and right sides of the winding and the product of the winding length:

$$\Phi_s = (\mathbf{A}_{1s} - \mathbf{A}_{2s}) \cdot l_{Fe} \quad (2.3)$$

Multiplying the magnetic flux by a total number of windings gives a flux linkage  $\Psi$ :

$$\Psi = N \cdot \Phi \quad (2.4)$$

After the FEM calculation on the IPMSM is completed, obtained three-phase values are transformed back into a two-axis coordinate system, by the inverse transformation matrix. The result of numerical and experimental determination are flux linkages  $\Psi_d$  and  $\Psi_q$  as functions of currents  $i_d, i_q$  and rotor position  $\theta$ .

The current and position dependent flux linkages, which represent the parameters of the dynamic model, can be solved by a model with distributed parameters using FEM. Numerical calculation with FEM is carried out in a real coordinate system for IPMSM, i.e. in a three-phase system. In the calculation of FEM, the values of three-phase currents must be inserted, which, in turn, are solved by the currents of the two-axis model with two-phase to three-phase transformation. To calculate the three-phase input alternating currents for the numerical algorithm, transformation matrices must be used, with which it is possible to change from a two-axis position system to a three-phase time system, and vice versa.

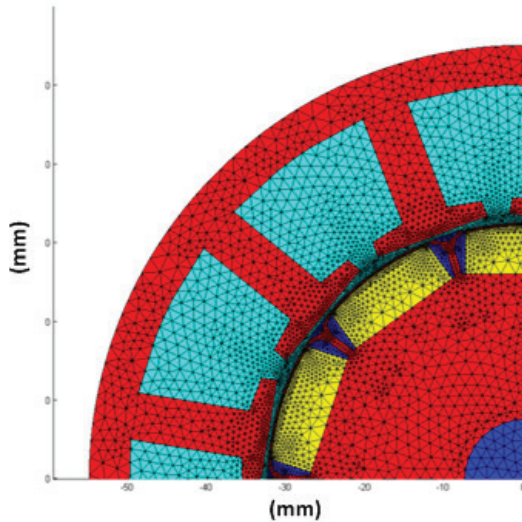

**Figure 1:** Discretisation of space on finite elements

The condition for the correct use of transformation matrices is that the magnetic conditions do not change during the transformation [2,4,5].

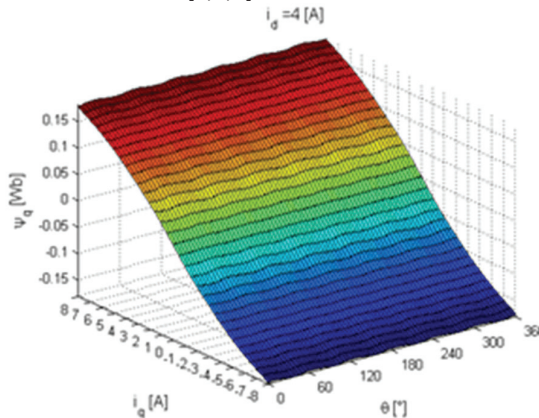

**Figure 2:** Graphic representation of the magnetic flux linkage distribution  $\Psi_q$  for current  $i_d = 4$  A

The results of FEM calculation are flux linkages:  $\Psi_a(i_a, i_b, i_c, \theta)$ ,  $\Psi_b(i_a, i_b, i_c, \theta)$  and  $\Psi_c(i_a, i_b, i_c, \theta)$ . Furthermore, using a three-phase to two-axis transformation, it is necessary to convert the linked magnetic fluxes into a two-axis model  $\Psi_d(i_d, i_q, \theta)$  and  $\Psi_q(i_d, i_q, \theta)$  used in a magnetically nonlinear dynamic model. The magnetic nonlinear properties to be determined can be divided into two groups. The first group includes flux linkages that result from the excitation of permanent magnets. These flux linkages are current independent. The second group are flux linkages resulting from stator currents.

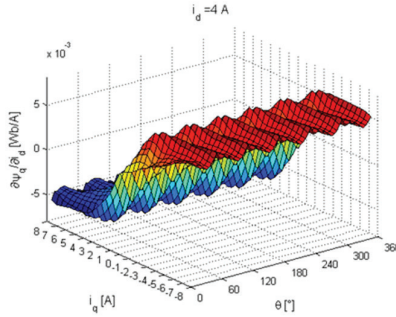
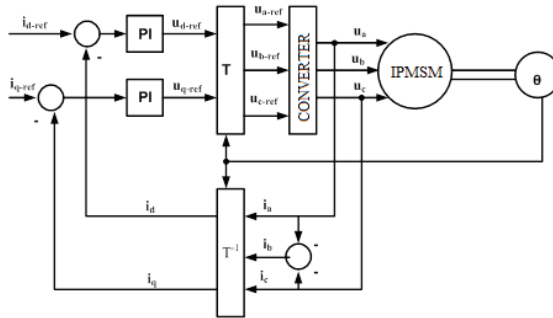

**Figure 3:** Graphic representation of the distribution of partial derivation  $\partial \Psi_q / \partial i_d$  for current  $i_d = 4 \text{ A}$

The numerical calculations of FEM for the flux linkages were done by discretisation of the motor through 38 616 derivations in the form of a three-dimensional graph.

### 3 EXPERIMENTAL DETERMINATION OF FLUX LINKAGES CAUSED BY STATOR CURRENTS

The parameters of a dynamic model of a synchronous motor can be determined experimentally, because the flux linkages in the d-axis  $\Psi_d(i_d, i_q, \theta)$  and in the q-axis  $\Psi_q(i_q, i_d, \theta)$  depend on the currents and the rotor position, while the flux linkages of permanent magnets  $\Psi_{mdq}(\theta)$  depend only on the rotor position. The flux linkages ( $\Psi_d$  and  $\Psi_q$ ) in d and q-axes are determined by an experiment with a locked rotor, whereby the position of the rotor must be known [ 5,6].



**Figure 4:** Measuring system for determining current and position dependent flux linkages

The procedure is carried out by applying a rectangular variable voltage in one axis and a constant current in the other axis. The measuring system for determining current and position-dependent

flux linkages flows is shown in Figure 4. The elements of the measuring system are: The tested IPMSM motor, a three-phase converter, a module with a signal processor with input and output units, a module for pulse-width modulation, a rotor position meter (MP), two measuring converters for current measurement. Current control is performed via PI regulators. [7,8] The voltage converter applies the constant current  $i_q$  in the q-axis, and the variable rectangular voltage  $u_d$  of a certain period in the d-axis. The duration of this period is determined as the time during which the current assumes a constant value in the greater part of the half-period.

In further examples, flux linkages are determined with given current values. As the rotor is locked, all members in the voltage equation with change in the angle  $d\theta$  are dropped, so the equation takes the form [9]:

$$u_d = i_d R_d + \frac{d\psi_d}{dt} \tag{3.1}$$

For the calculation of the flux linkage  $\psi_d$  numerical integration must be applied:

$$\psi_d(t) = \int_0^t (u_d(\tau) - Ri_d(\tau)) d\tau \tag{3.2}$$

According to this expression, flux linkages  $\Psi_d$  and  $\Psi_q$  are calculated for  $i_q=7$  A,  $i_d=0$ , at time period  $T = 0.4$  s with numerical integration to be compared with the experimentally obtained values.

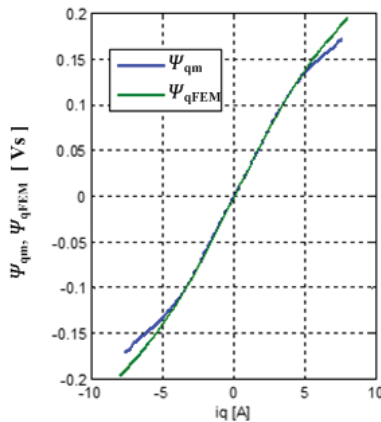

**Figure 5:** Comparison of the measured  $\Psi_{qm}$  and numerically calculated  $\Psi_{qFEM}$  as a function of current  $i_q$

A comparison of the measured results with the values obtained by the FEM calculation can be seen in Fig. 5, and only small deviations are observed. The deviations can be explained with the error of the numerical calculation, as well as the non-uniform voltages and currents applied to the stator winding from the frequency converter. Given the curve dependencies of flux linkages are about current values (in this case the values are currents from -8 A to 8 A, with a step of 0.5A) they can provide the uniform (i) characteristic at characteristic current values. From the uniform characteristics thus obtained, two two-dimensional matrices can be formed: Current and position-dependent magnetic fluxes  $\Psi_d(i_d, i_q, \theta)$  and  $\Psi_q(i_d, i_q, \theta)$ .

## 4 EXPERIMENTAL DETERMINATION OF THE PERMANENT MAGNET FLUX LINKAGES

The measurement of the induced voltage on the stator windings is carried out at a constant rotor speed. The measuring system for determining the flux linkage of permanent magnets, shown in Figure 6, consists of a DM drive machine controlled by a measuring transducer. The DM drive machine is connected mechanically to the tested IPMSM motor by an axle on which the MP rotor position transducer is also installed. The induced voltages in all three phases of the tested motor are measured by a voltage converter VC and stored in a PC via the A/D card as a rotor position data. In this case, the stator currents in d-axis and q-axis are equal to zero, and only the flux linkages of the permanent magnets in d-axis and q-axis and the angular velocity remain [5].

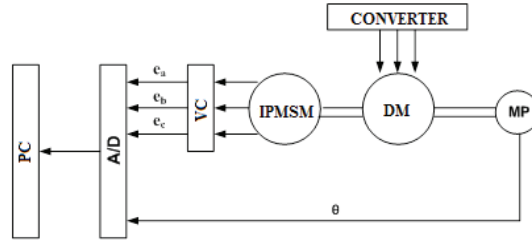

Figure 6: Measurement system for determining the flux linkages of permanent magnets

For the open terminals on the stator, the voltage equations have the form:

$$e_d = -\Psi_{mq} \frac{d\theta}{dt} + \frac{\partial \Psi_{md}}{\partial \Theta} \frac{d\theta}{dt} \quad (4.1)$$

$$e_q = \Psi_{md} \frac{d\theta}{dt} + \frac{\partial \Psi_{mq}}{\partial \Theta} \frac{d\theta}{dt} \quad (4.2)$$

After sorting, a second-order partial differential equations for  $\Psi_{md}$  and  $\Psi_{mq}$  are obtained:

$$\Psi_{md} + \frac{\partial^2 \Psi_{md}}{\partial \theta^2} = \frac{\partial}{\partial \theta} \left( \frac{e_d}{\omega} \right) + \frac{e_q}{\omega} \quad (4.3)$$

$$\Psi_{mq} + \frac{\partial^2 \Psi_{mq}}{\partial \theta^2} = \frac{\partial}{\partial \theta} \left( \frac{e_q}{\omega} \right) - \frac{e_d}{\omega} \quad (4.4)$$

The numerical solution of these equations for the measured values of induced voltages and the given frequency, gives the values of the flux linkages of the permanent magnets, depending on the position of the rotor. An example of the calculation of the flux linkage of permanent magnets is carried out in such a way that the rotor rotates at a constant rated speed, and the three-phase induced voltages  $e_a$ ,  $e_b$  and  $e_c$  are recorded on open stator terminals which are transformed into a two-axis d-q system  $e_d$  and  $e_q$ . [10-12]

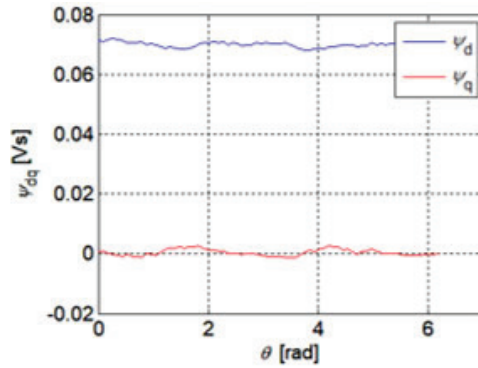

Figure 7: Flux linkages in the d-q axis obtained by the measurement

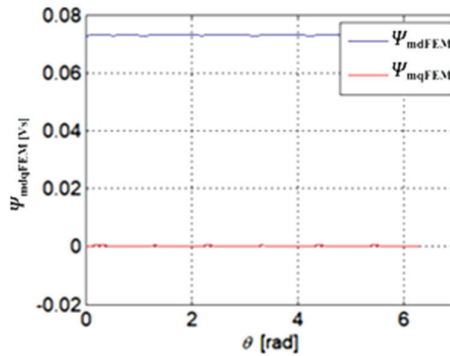

Figure 8: Flux linkages in d-q axis obtained by the FEM calculation

Solution of the system of equations (Eq. 4.1 - Eq. 4.4) for the flux linkages of the permanent magnet  $\Psi_{md}$  and  $\Psi_{mq}$  is shown in Fig. 7, while solution using the FEM calculation is shown in Fig. 8.

### 3 CONCLUSION

The problem of creating a magnetic nonlinear model and incorporating the results of the FEM calculations (distributed parameters) was solved by analysing all the subsystems (electrical and mechanical) that are connected nonlinearly.

The paper explains an algorithm for the correct definition of the model using partial differential equations, i.e. the calculation of the partial derivatives of the flux linkages. The magnetically nonlinear dynamic model of IPMSM is useless as long as the magnetically nonlinear properties and their partial derivatives are undetermined.

These magnetically nonlinear characteristics represent the variable parameters of the derived model and are determined by the Finite Element Method (FEM). To verify the model, i.e. the numerical calculations of the FEM, a measuring system was prepared and experimental testing was performed on the sample IPMSM.



## References

- [1] **Jacek F. Gieras**, "Permanent magnet motor technology: design and applications", CRC Press, 2010.
- [2] **T. Marčić, G. Štumberger, B. Štumberger, M. Hadžiselimović and P. Vrtič**, "Determining Parameters of a Line-Start Interior Permanent Magnet Synchronous Motor Model by the Differential Evolution", in IEEE Transactions on Magnetics, vol. 44, no. 11, pp. 4385-4388, Nov. 2008
- [3] **C. C. Hwang, S. P. Cheng, and C. M. Chang**, "Design of High-Performance Spindle Motors With Concentrated Windings", IEEE Transactions On Magnetics, Vol. 41, No. 2, February 2005.
- [4] **G. H. Kang, J. P. Hong, G. T. Kim, and J. W. Park**, "Improved parameter modeling of interior permanent magnet synchronous motor based on finite element analysis", IEEE Trans. Magn., vol. 36, pp. 1867-1870, July 2000.
- [5] **Z. Xinghua and C. Pengfei**, "Efficiency optimization of a direct torque controlled interior permanent magnet synchronous motor considering iron losses", 2016 19th International Conference on Electrical Machines and Systems (ICEMS), 2016, pp. 1-5.
- [6] **S. P. Lim and K. J. Tseng**, "Dynamic model of an interior permanent magnet motor with skewed stator slots," IECON'99. Conference Proceedings. 25th Annual Conference of the IEEE Industrial Electronics Society (Cat. No.99CH37029), 1999, pp. 1471-1476 vol.3
- [7] **M. Hadžiselimović, G. Štumberger, B. Štumberger and I. Zagradišnik**, "Magnetically nonlinear dynamic model of a synchronous motor with permanent magnets", J. Magn. Mater., vol. 316, pp. e257-e260, 2007.
- [8] **A. Khlaief, M. Bendjedia, M. Boussak and M. Gossa**, "A nonlinear observer for high-performance sensorless speed control of IPMSM drive", IEEE Trans. Power Electron., vol. 27, no. 6, pp. 3028-3040, Jun. 2012
- [9] **N. Yang, G. Luo, W. Liu and K. Wang**, "Interior permanent magnet synchronous motor control for an electric vehicle using a look-up table", Proceedings of The 7th International Power Electronics and Motion Control Conference, 2012, pp. 1015-1019
- [10] **S. P. Lim and K. J. Tseng**, "Dynamic model of an interior permanent magnet motor with skewed stator slots", IECON'99. Conference Proceedings. 25th Annual Conference of the IEEE Industrial Electronics Society (Cat. No.99CH37029), 1999, pp. 1471-1476 vol.3
- [11] **X. Xiao, C. Chen and M. Zhang**, "Dynamic Permanent Magnet Flux Estimation of Permanent Magnet Synchronous Machines", in IEEE Transactions on Applied Superconductivity, vol. 20, no. 3, pp. 1085-1088, June 2010
- [12] **E. Sokolov and M. Mihov**, "Parameter Estimation of an Interior Permanent Magnet Synchronous Motor", 2019 16th Conference on Electrical Machines, Drives and Power Systems (ELMA), 2019, pp. 1-5