

Analiza delovanja pnevmatičnega ventila s predkrmilnim piezoventilom

Analysis of the Operation of Pilot-Stage Piezo-Actuator Valves

Niko Herakovič - Dragica Noe
(Fakulteta za strojništvo, Ljubljana)

Zaradi vse večjih zahtev po boljših dinamičnih lastnostih in manjši porabi energije pnevmatičnih ventilov, je treba nenehno izboljševati sedanje elektromagnetne izvršilnike, obenem pa raziskati možnosti uporabe alternativnih aktuatorjev. Odkar so piezoelektrični izvršilniki, predvsem upogibni, pridobili na preprostosti oz. cenenosti, hitrosti delovanja in zanesljivosti, so v zadnjih letih pritegnili veliko pozornosti tudi za uporabo pri krmiljenju pnevmatičnih ventilov. V okviru predstavljene raziskave je bil razvit predkrmilni ventil z dvema upogibnima piezoelementoma ter prigraven standardnemu pnevmatičnemu ventilu velikosti ISO 3, 5/2. V prispevku so prikazane bistvene značilnosti piezoelementov, možnosti uporabe le-teh za krmiljenje pnevmatičnih ventilov in na koncu analiza ventila s predkrmilnim piezoelementom.

© 2006 Strojniški vestnik. Vse pravice pridržane.

(Ključne besede: ventili pnevmatični, analize delovanja, predkrmiljenje ventilov, elementi piezoelektrični)

Due to the ever-growing demands for better dynamic properties and lower energy consumption for pneumatic valves, constant efforts to improve existing electromagnetic actuators are required, while at the same time new possibilities for alternative actuators are being searched for. Since piezoelectric actuators, especially the bender type, have become low-cost, easy to use, faster and more reliable in operation, they have also attracted a lot of attention in pneumatic control-valve applications. The presented study reports on the experimental development of a pilot-stage valve with two bending piezo-elements attached to a standard pneumatic valve of size ISO 3, 5/2. The most important characteristics of piezo-actuators and the possibilities for their use in pneumatic control valves are discussed, and the features of the developed pilot-stage piezo-actuator valve are presented.

© 2006 Journal of Mechanical Engineering. All rights reserved.

(Keywords: pneumatic valves, operation analysis, piezo-controlled hydraulic pilot stage, piezo-elements)

0 UVOD

Pri razvoju ventilov se srečujemo z zahtevami po čim manjših izmerah, dobrih dinamičnih značilkah ter čim manjšo porabo električne energije. Pogosto se zahteva izpolnjevanje vseh treh meril. Tehnične izboljšave pri razvoju pnevmatičnih ventilov pa bo mogoče doseči tako z optimizacijo konstrukcije kakor tudi z novimi načini krmiljenja in uporabo novih materialov [1]. Raziskave na področju razvoja predkrmilnih pnevmatičnih ventilov so pokazale, da je uporaba elektromagnetnih izvršilnikov, kot predkrmilnih ventilov, omejena in je treba iskati nove rešitve. Ugotoviti je mogoče, da dosedanja uporaba piezoelektričnih pogonov v razvoju

0 INTRODUCTION

In the design and development of valves, the requirements that have to be met are the smallest possible dimensions, good dynamic characteristics and the lowest possible electric power consumption. Quite often these three criteria have to be fulfilled. Technical improvements in the development of pneumatic valves can be achieved by optimizing the design as well as introducing new principles of pneumatic control and new materials [1]. Research in the field of pilot-stage pneumatic valves has shown that the use of electromagnetic actuators in the pilot-stage has its own restrictions and that new solutions have to be sought. On the other hand, it can be established that in the development of fluid-power components and

fluidnotehničnih komponent in drugih mehatronskih sistemov kaže obetavne rezultate ([2] do [6]).

Razvoj piezoelektričnih izvršilnikov zahteva dobro poznavanje piezotehnike, postopka izdelave piezoelementov ter možnosti, ki jih posamezne izvedbe piezoelementov ponujajo. Pomembna sta tako raztezek in sile, oblike in izmere piezoelementov pa so lahko prilagojene vsakokratni uporabi.

V predkrmilnih ventilih so bili v predhodnih raziskavah uporabljeni predvsem upogibni konzolni piezoelementi ([6],[10] in [18]). Namen naše raziskave pa je analizirati možnosti uporabe mostičnega piezoelementa [1]. Zato je bil okviru raziskave standardni izvedbi pnevmatičnega potnega ventila, namesto magnetnih premikal, prigraden predkrmilni ventil z mostičnim piezoizvršilnikom, rezultate delovanja oz. značilke ventila pa smo primerjali z elektromagnetnim predkrmilnim ventilom.

1 IZHODIŠČA ZA RAZVOJ VENTILA S PREDKRMILNIM PIEZOVENTILOM

Pnevmatični posredno krmiljeni ventili so zgrajeni iz glavnega ventila, ki usmerja zrak od napajanja k porabniku ter predkrmilnega ventila (pk1 in pk2), ki preklaplja oziroma krmili glavni ventil – gv (sl. 1). Naloga predkrmilnega ventila je spremeniti električno energijo v mehansko delo, oziroma premik zapirnega elementa, ki usmerja krmilni zrak na krmilni priključek glavnega ventila. Na ta način so izmere izvršilnikov predkrmilnega ventila manjše, manjša pa je tudi poraba moči.

V preteklosti je bilo razvitih več načinov pogonov, ki električni signal spremenijo v silo ali premik. Naloga pogona je povezovati električni krmilni obtok s pnevmatičnim, oziroma spremeniti električno energijo v energijo

other mechatronic systems the use of piezoelectric actuators has become very promising ([2] to [6]).

The development of piezoelectric actuators requires a good knowledge of piezo technology, manufacturing procedures and the possibilities offered by their particular designs. Factors that are important to consider are the extension and the force, while the shapes and sizes of piezo elements can be adapted to each particular application.

In pilot-stage valve applications, previous researchers have mainly used bending cantilever piezo-elements ([6],[10] and [18]). The aim of our study was to analyze the use of another possible type, i.e., a bending crossbow piezo-element [1]. For this purpose, a pilot-stage valve with a crossbow piezo-actuator was built to a standard pneumatic directional valve, and the results and the characteristics of the thus obtained valve were compared to an electromagnetic pilot-stage valve.

1 CONSIDERATIONS IN THE DESIGN OF PILOT-STAGE PIEZO-ACTUATOR VALVE

Pneumatic pilot-stage valves consist of the main valve that directs the air from the supply source to the consumer and a pilot-stage component (pk1 and pk2) that switches on/off the main valve (gv), Fig 1. The task of the pilot-stage valve is to convert the electrical energy into mechanical work or displacement of the closing element, which then directs the controlling air onto the control element of the main valve. This kind of design makes it possible for the dimensions of pilot-stage actuators to be smaller and the power consumption to be lower.

In the past, a number of actuator principles for converting an electrical signal into a force or motion have been developed. The task of the actuator is to connect the electrical control circuit with the pneumatic circuit, or, in other words, to convert the electri-

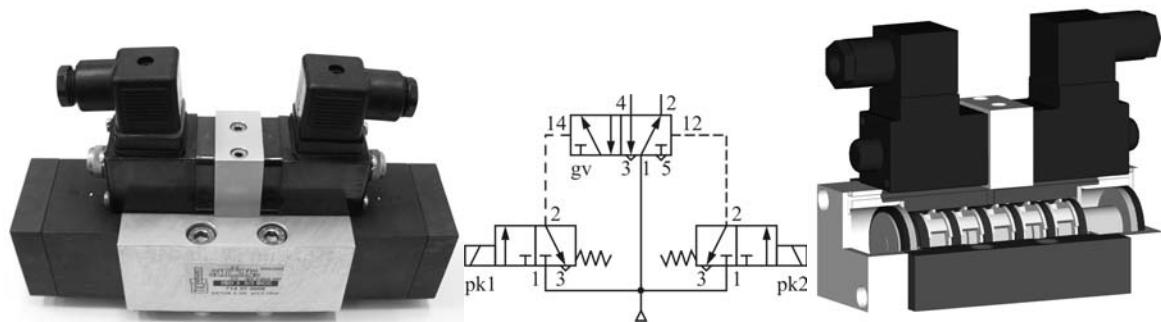

Sl. 1. Elektromagnetni posredno krmiljeni pnevmatični 5/2 potni ventil [17]
Fig. 1. Electromagnetic pilot-stage directional pneumatic valve 5/2 [17]

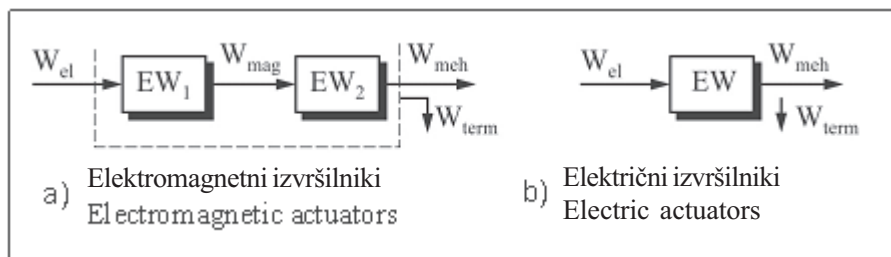

Sl. 2. Spreminjanje električne energije v mehansko

Fig. 2. Conversion of electrical energy into mechanical energy

stisnjenega zraka. Po načinu delovanja so elektromehanski pretvorniki (EP) razdeljeni v elektromagnetne in električne izvršilnike. Elektromagnetni najprej električno energijo spremenijo v magnetno energijo in nato v mehansko, pri električnih pa je ta sprememba neposredna (sl. 2 a in b).

Vprašanje je, kakšne možnosti ima elektromagnetni izvršilnik v smislu skrajševanja preklonnih časov, zmanjševanja izmer ter zmanjševanja porabe moči. V fizikalnem smislu nastanejo, zaradi magnetne indukcije in vrtničnih tokov pri vklopu električnega toka, zakasnitve pri preklonu. Preklonni časi so tem krajši, čim manjše so mase gibljivih delov in čim krajši je gib jedra tuljave. Pri najboljši izvedbi elektromagnetnih premikal so preklonni časi v območju 500 μ s, za običajne izvedbe ventilov pa je čas preklopa med 10 in 20 ms. Pomembna za uporabnike pa je tudi ponovljivost preklapljanja v vsej dobi trajanja v pričakovanem okolju. Posebni ventili lahko dosežejo ponovljivost tudi pri 100 milijonih gibov ([1], [3], [6] in [7]).

Naslednji ukrepi, ki jih je mogoče zaslediti pri razvoju elektromagnetnih predkrmilnih ventilov, so povezani z zmanjševanjem prostornine pnevmatičnih komponent pri enakih ali celo povečanih pretokih stisnjenega zraka. Trenutno se je zmanjševanje ustavilo pri 10 mm. Nadaljnje zmanjševanje izmer onemogočajo elektromagnetni izvršilniki. Izdelava manjših ventilov je zaradi zahtevnih tehnoloških postopkov manjših elektromagnetov ekonomsko neupravičena. Napredek je mogoče iskati v smeri izvršilnikov na podlagi silicija. Trenutno je tako imenovana mikropnevmatika, pri kateri so izmere pnevmatičnih predkrmilnih ventilov samo nekaj mm, na začetku svojega razvoja. Problem, ki nastane pri zmanjševanju izmer, se kaže dandanes v nesorazmerju pnevmatičnega dela s priključki za zaznavala, pri

cal energy into the energy of compressed air. In terms of operation, electro-mechanical transducers (EP) can be divided into electromagnetic and electrical actuators. The electromagnetic actuators convert electrical energy first into magnetic energy and then into mechanical energy, whereas the electrical actuators transform it directly (Fig 2 a and b).

The potentials of the electromagnetic actuators are questionable when factors such as shorter switchover times, smaller dimensions and lower power consumption are considered. In the physical sense, due to magnetic induction and eddy currents during switching the current on, delays in switchover occur: the shorter the switchover times, the lower are the masses of the moving parts and the shorter is the movement of the core of the coil. In optimal electromagnetic-actuator design solutions, the switchover times are in the range of 500 μ s, while for standard valve designs the switchover time ranges between 10 to 20 ms. The switchover repeatability during the life time in a foreseen environment is also important for customers. Special valves may reach a repeatability as high as 100 million strokes ([1], [3], [6] and [7]).

Some efforts in the development of electromagnetic pilot-stage valves are directed into reducing the volume of the pneumatic component at equal or even higher compressed air-flow rates. So far the reductions have stopped at 10 mm^3 . A further scale-down of dimensions is not possible because of the electromagnetic actuators. Due to demanding technological procedures the manufacturing of smaller valves is not economically justifiable. However, an advancement could be looked for in the direction of making actuators based on silicon. Currently, the so-called micro-pneumatics, where the dimensions of pneumatic pilot-stage valves reach just a few mm, is still in its early stages. The problem in scaling down the dimensions is in the disproportion between the pneumatic part and the sensor connectors, where the pneumatic part can be

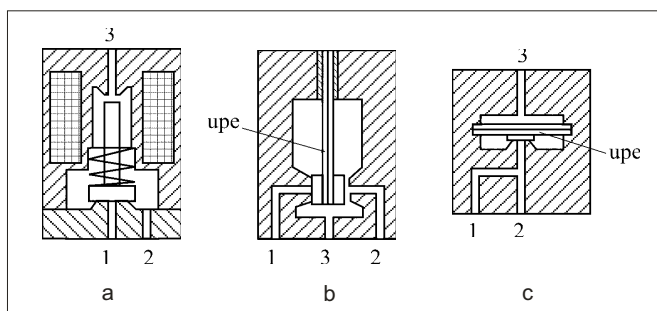

Sl. 3. Izvedbe predkrmilnih ventilov, a - elektromagnetni, b - z dvoslojnim upogibnim piezoelementom, c - z mostičnim piezoelementom - izvedba z odbojno šobo, upe - upogibni piezoelement
 Fig. 3. Designs of pilot-stage valves a - electromagnetic, b - two-layer bending piezo-element, c - crossbow piezo-element – flapper nozzle system, upe - bending piezo-element

katerih je pnevmatični del bistveno manjših izmer od priključkov za zaznavala. Za zdaj tu še ni ustreznih rešitev (M12 priključek je sedaj še nujnost) [6].

Več razlogov narekuje razvoj učinkovitih elektromehanskih pretvornikov, ki se uporabljajo v vrsti elektronskih naprav in nenazadnje tudi v pnevmatiki. Eden izmed njih je tudi zahteva po energetsko varčnih komponentah in je posledica zahtev po varčevanju energije v vseh vrstah uporab. Razviti so piezoelektrični, elektrouporni, magnetouporni, spominski elementi, elektromagnetni itn. [1]. Za velike dinamične zahteve je piezoelektrični izvršilnik prav gotovo najprimernejši. Prednost piezoelektričnih materialov je v tem, da spreminjajo električno energijo v mehansko in nasprotno skoraj brez izgub (sl. 2).

Med različnimi izvedbami električnih izvršilnikov imajo piezoelektrični največje možnosti za široko in ekonomsko upravičeno uporabo ([4], [6] in [7]). Ker so v pnevmatiki preklapne sile, v primerjavi s hidravliko majhne, so primerni za uporabo predvsem upogibni piezoizvršilniki oziroma elementi. Razvoj piezo materialov in pogonov je v zadnjih letih močno napredoval, tako da je mogoče z uporabo novih materialov in tehnologij izdelati upogibne piezoizvršilnike, primerne za krmilne sile tudi do 100 N ali v posebnih izvedbah do 1 kN [15]. V pnevmatiki so se do sedaj v največji meri uporabljali predvsem konzolni upogibni piezoelementi, vendar imajo tudi mostični piezoelementi primerne značilnosti za uporabo pri krmiljenju potnih ventilov (sl. 3).

2 UPOGIBNI PIEZOIZVRŠILNIKI

Piezopojav je lastnost številnih materialov, ki jih najdemo v naravi. Njihova poglavitna značilnost

je bistveno manjša od priključkov. At the current stage of development there are still no suitable solutions available (an M12 connection is still a necessity) [6].

There is a growing need to develop efficient electro-mechanical transducers that can be used in electronic devices and fluid power systems. One reason for this is the need for energy-saving as a general trend in all kinds of applications. Some of the most recent developments are piezoelectric, magnetoresistive, electromagnetic and shape-memory elements [1]. There is no doubt that for high-dynamic-load applications the piezoelectric actuators are the best choice. The advantage of piezoelectric materials lies in the fact that they convert electrical energy into mechanical and vice versa, almost without any losses (Fig 2).

Among the various kinds of electric actuator, the piezoelectric actuators have the best chance to become widespread and economically justifiable. ([4], [6] and [7]). Since in pneumatic systems the switchover forces are low compared to hydraulic systems, the bending piezo-actuators are the ones that are especially suitable for pneumatic applications. Recently, there has been considerable progress in the development of piezo-materials and piezo-actuators so that with the use of new materials and technologies it is possible to manufacture bending piezo-actuators suitable for control forces up to 100 N, or in cases of special design, even 1 kN [15]. In pneumatic systems, cantilever bending piezo-actuators are mostly used, though the crossbow piezo-actuators also possess properties suitable for use in directional control valves (Fig 3).

2 BENDING PIEZO-ACTUATORS

The piezo effect is a feature of numerous materials found in nature. Their basic characteristic is

je ta, da se na kristalu pri mehanski deformaciji, zaradi tlačne ali natezne sile, pojavi električni naboj. Ta pojav je imenovan tudi neposredni piezopojav. Nasprotni pojav, ko se kristal pod vplivom električnega polja deformira – skrči ali raztegne, pa se imenuje inverzni ali povratni piezopojav in je uporaben za premikala oziroma pogone.

2.1 Osnovna načela delovanja

Za razumevanje povratnega piezopojava, ki sta ga opredelila v letu 1881 Curie in Lippman ([8] in [9]) je treba razumeti *električno polarnost*, katere povzročitelji so *električni dipoli*. Pri tem je električni dipol primerljiv z magnetnim, torej s tako imenovanim elementarnim magnetom vendar v električnem smislu. Dipol je mogoče prikazati z negativnim ($-q$) in pozitivnim nabojem ($+q$) in puščico, ki je usmerjena od negativnega k pozitivnemu dipolu. Opisati ga je mogoče z momentom dipola, z vektorjem p , ki je definiran kot zmnožek naboja q in medsebojne oddaljenosti l in je podan v enoti dolžine (sl. 4 a).

Električna polariteta je lahko naravna ali pa nastane pri delovanju električnega polja na nepolarizirane atome - spontana polarizacija. Polarizacija je lahko trajna ali pa po prenehanju delovanja električnega polja izgine. Za razvoj piezopogonov je zanimiva trajna ali permanentna polarnost.

Dipol se v močnem električnem polju E usmeri glede na smer polja. Pri tem deluje na pozitivni del dipola sila F_1 v smeri električnega polja in sila F_2 v nasprotni smeri (sl. 4 b). Dvojica sil se izrazi kot vrtilni moment M , ki je enak zmnožku potenciala p in električnega polja E ($M = p \cdot E$).

that on a crystal subjected to mechanical deformation, as a result of compressive and tensile forces, an electrical charge is created. This effect is also known as the direct piezo effect. The opposite phenomenon, when under the influence of an electric field the crystal deforms, i.e., it contracts or extends, is called the reverse piezo effect. This is used in actuators.

2.1 Basic principles of operation

The reverse piezo-effect, first described in 1881 by Curie and Lippman ([8] and [9]), can be explained by the electrical polarity caused by electric dipoles. Here, the electrical dipole is comparable to the magnetic one, i.e., to the so-called elementary magnet, but in the electrical sense. A dipole can be presented with a negative ($-q$) and positive charge ($+q$) and an arrow directed from the negative to the positive dipole. It can be defined by the dipole moment, vector p , defined as the product of the charge q and the distance l between them, Fig 4a.

Electrical polarity can be natural or can occur when an electrical field acts on non-polarized atoms, i.e., spontaneous polarization. Polarization can be permanent or can disappear after the electrical field stops acting. It is the permanent polarization that is of interest in the development of piezo-actuators.

In a strong electric field, E , a dipole aligns with the direction of the electric field. In this way only the positive part of the dipole is acted on by force F_1 in the direction of the electrical field, and F_2 in the reverse direction (Fig 4b). The force couple expresses itself as a rotating moment M equal to the product of the potential, p , and the electrical field E ($M = p \cdot E$).

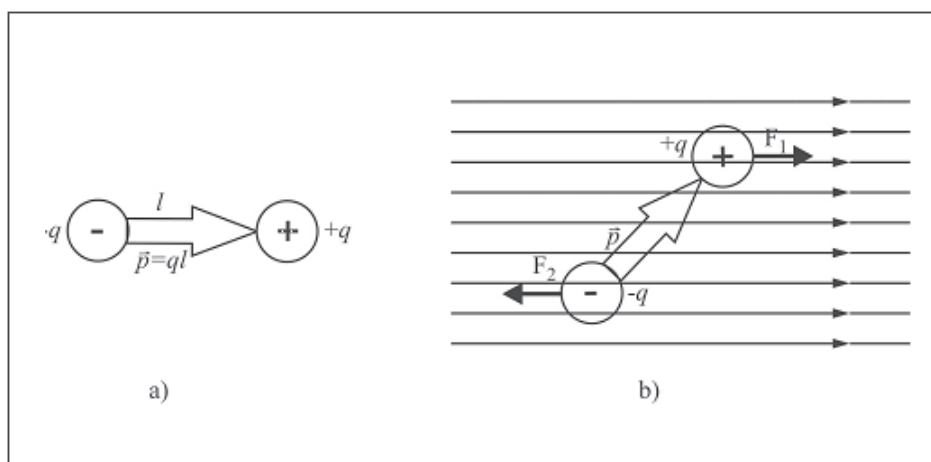

Sl. 4. Dipol (a) in dipol v električnem polju (b)
Fig. 4. Dipole (a) and dipole in the electric field (b)

Za dipole v dielektriku velja, da so naključno usmerjeni in je material navzven nevtralen. S postavitvijo materiala v električno polje se dipoli ustrezno usmerijo in na površini dielektrika nastane površinski naboj.

Kadar govorimo o dipolih v trdnih telesih, mislimo s tem polarizirane elementarne kristalne mreže. Najbolj znan piezomaterial je kremen, vendar piezopojav pri njem ni dovolj izrazit, sile so majhne in tako ni primeren za krmiljenje pnevmatičnih ventilov. Mnogo primernejši materiali so različne feroelektrične keramike, med njimi barijev titanat (BaTiO_3), svinčev titanat, svinčev cirkonat in svinčev cirkonat-titanat (PZT). Fizikalne lastnosti PZT piezokeramike so odvisne od mešanice cirkonija in titanata in dodanih drugih materialov, ki so specifični za posamezne izdelovalce piezoelementov.

Kristaliti PZT so pred polarizacijo centrosimetrično kubični (izotropno), po polarizaciji pa kažejo tetragonalno simetrijo (anizotropna sestava), in sicer v pogojih, ko vrednost temperature ne presega Curie-jeve temperature [9]. Nad to temperaturo kristali izgubijo piezoelektrične lastnosti.

V piezomaterialu, ki je zgrajen iz več osnovnih kristalov, so dipoli umerjeni naključno. Vendar se v materialu najdejo skupine kristalov oziroma dipolov, ki so enako usmerjene. Take skupine so označene kot območja, ki v bistvu ustrezajo makroskopskemu dipolu, saj so znotraj polarizirane. Ker so ta območja ponovno naključno usmerjena, kristal na zunaj ne kaže polarnosti. Če se tak material postavi v močno električno polje nekaj kV na mm dolžine, se območja pričnejo usmerjati, posamezne skupine jeder kristala dobijo enako usmerjenost in jedra rastejo na račun drugih. Z zamrznitvijo polariziranega stanja dobimo piezoelektrični kristal s polarizirano osjo. Pod Curie-

Dipoles in a dielectric fluid have a random sense of direction, and outwardly the material acts as neutral. By placing the material into an electric field, the dipoles align accordingly, and on the surface of the dielectric a surface charge is produced.

Dipoles in reference solids are displayed as polarized elementary crystals in the crystal lattice. As is commonly known, quartz is a piezo-material; however, in quartz the piezo effect is not distinct enough, the forces induced are small, which makes it inappropriate for use in pneumatic valves. Much more suitable materials include some ferromagnetic ceramics, among them barium-titanate (BaTiO_3), lead-titanate, lead-zirconate and lead-zirconate-titanate (PZT). The physical properties of PZT piezo-ceramics depend on the proportion of zirconium and titanium and their additions specific for each particular manufacturer of piezo-elements.

Prior to polarization PZT crystallites are axisymmetrical cubes (isotropic), after the polarization, however, they display a tetragonal symmetry (anisotropic structure), and this is in conditions when the temperature does not exceed the Curie temperature [9]. Above this temperature the crystals lose their piezoelectric properties.

In a piezo material made from several basic crystals, the dipoles are directed randomly. However, in the material it is possible to find groups of crystals that have the same direction. These groups are marked as domains and actually correspond to the macroscopic dipole because they are polarized on the inside. Since these domains again are randomly directed, on the outside the crystal does not display any polarity. If such materials are subjected to a strong electric field of a few kV per mm of length, the domains start aligning themselves, and particular groups in the crystal core become equally directed and these cores start growing at the expense of others. By freezing such a polarized state, a piezoelectric crystal with a polarized axis is obtained. Below the Curie temperature and on removal

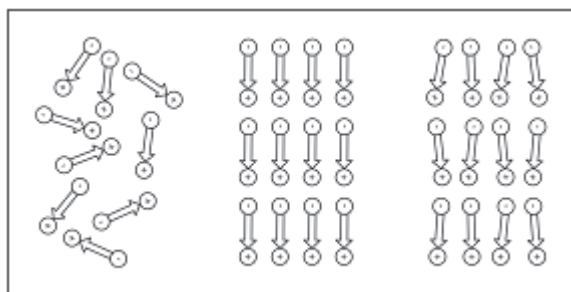

Sl. 5. Predstavitev posameznih kristalnih zrn in njihovih območij
Fig 5. Presentation of crystal grains and their domains

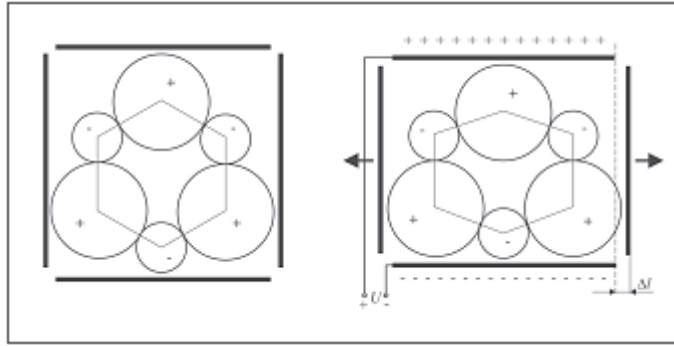

Sl. 6. Deformacija kristalne rešetke pri postavitvi v električno polje
 Fig. 6. Deformation of crystal lattice when subjected to electric field

jevo temperaturo in po odstranitvi električnega polja se dipoli sicer nekoliko razbremenijo, vendar v večini ostanejo v dani usmerjenosti (sl. 5).

Pri ponovni postavitvi piezoelektrične keramike v električno polje se polarizacija območij ponovno ojači in kristal se deformira, oziroma razširi vzdolž osi polarizacije (sl. 6).

Deformacija kristala Δl je odvisna od jakosti električnega polja E oziroma napetosti U in piezo modula d_{ij} , kjer je i smer električnega polja v kartezičnem koordinatnem sistemu in j smer deformacije za dano polarizacijo kristala (sl. 7).

$$\Delta l = d_{ij} \cdot E \cdot l_0 = d_{ij} \cdot l_0 \cdot U/l_0 = d_{ij} \cdot U \tag{1}$$

Glede na smer delovanja električnega polja in smer polarizacije se kristal lahko deformira v smeri polarizacije ali pravokotno na polarizacijo. Tako predstavlja piezomodul d_{33} vzdolžno deformacijo kristala v smeri osi z , ko je smer električnega polja enaka smeri prvotne polarizacije, v osi z , piezomodul d_{31} pa prečno deformacijo glede na smer električnega polja, ko je smer polarizacije v osi z in deformacija

of the electric field, the dipoles discharge slightly, but mainly remain in the given direction (Fig 5).

By putting the piezoelectric ceramic back into the electric field, the polarization of the domains intensifies again and the crystal deforms or extends along the polarization axis (Fig 6).

The deformation of the crystal depends on the intensity of the electric field, E , or the voltage, U , and piezo-module, d_{ij} , where i denotes the direction of the electric field in the Cartesian coordinate system and j the direction of deformation for a given polarization of the crystal (Fig 7).

With respect to the working direction of the electric field and the direction of polarization, the crystal may deform in the direction of polarization or perpendicularly to it. Thus, the piezo module, d_{33} , represents the longitudinal deformation of the crystal in the direction of the z -axis, when the sense of direction of the electrical field is the same as the direction of the original polarization in the z - axis, and the piezo-module d_{31} presents a transverse deformation with respect to the direction of

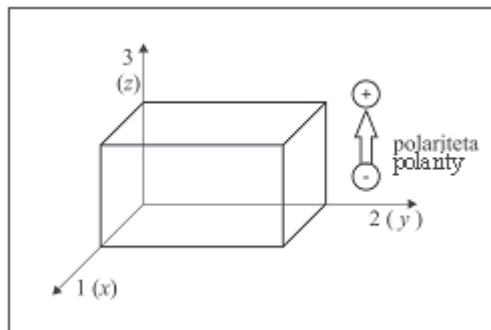

Sl. 7. Opredelitev indeksov piezomodula
 Fig. 7. Determination of the subscripts of a piezo module

pravokotno na os z . Za polikristalno keramiko PZT je vrednost modula d_{33} med vrednostjo 50 in 765 pm/V [11].

Pri izbiri piezoizvršilnikov, primernih za pogon pri pnevmatičnih ventilih, je poleg največjega raztezka aktuatorja Δl treba poznati še največjo dopustno silo F , ki jo lahko piezoizvršilnik doseže, ter točko delovanja glede na najboljšo silo in raztezek. Največja sila, imenovana tudi omejevalna sila, ki se vzpostavi v piezoelementu, ko je ta pod napetostjo in je vpet med dve absolutno togi površini, ki ne dopuščata raztezka - $\Delta l/l=0$. Sila je odvisna od vzmetne stalnice kristala in deformacije:

$$F = k_T \cdot d_{ij} \cdot U \quad (2),$$

kjer je k_T - vzmetna stalnica piezo kristala oziroma količnik togosti, ki je odvisen od vrste parametrov.

Primer delovnega diagrama piezoizvršilnika je podan na sliki 8. S tem diagramom, ki je specifičen za vsak piezoizvršilnik, je mogoče preprosto razbrati delovne točke piezoizvršilnika med obema mejnima vrednostima sile in raztezka. Najboljša točka delovanja vsakega piezoizvršilnika je na polovici zveznice med največjo silo in največjim upogibom oz. raztezkom (sl. 8).

Pri ogrevanju piezomaterialov nad Curie-jevo temperaturo T_c polarizacija kristalov piezoizvršilnika izgine. Podatek je pomemben prav za uporabo v

the electrical field, when the sense of direction of the polarization is in the z -axis and the deformation is perpendicular to the z -axis. For PZT polycrystalline ceramics the value of the module d_{33} ranges between 50 to 765 pm/V [11].

When selecting piezo-actuators suitable for pneumatic valves, besides the maximum elongation of the actuator, we also need to know the maximum allowable force F a piezo-actuator can reach, and the point of action with respect to the optimal force and extension. The maximum force, called the blocking force, is the force occurring in the piezo element when the latter is under stress and is fixed between two absolutely rigid surfaces allowing no extension, i.e., $\Delta l/l=0$. The force depends on the spring constant of the crystal and the deformation.

where k_T is the spring constant of the piezo-crystal or the coefficient of stiffness, depending on a number of parameters.

Figure 8 shows in a graph the optimal operating point of a piezo-actuator. From this force-deflection graph, which is specific for each piezo-actuator, we can easily see the operating points of piezo-actuators lying between the limit values of force and extension. The optimal operating point of each piezo-actuator is in the middle of the connecting line between the maximum force and the maximum deflection or extension (Fig. 8).

When piezo-materials are heated above the Curie temperature, T_c , the polarization of the crystals disappears. This data is important for high-

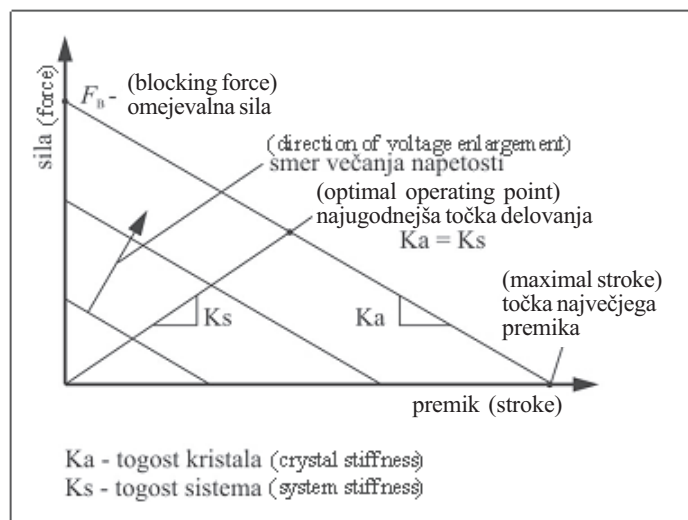

Sl. 8. Diagram sila - raztezek pri različnih električnih napetostih napajanja
Fig. 8. Force-deflection graph in relation to voltage

delovanju pri povišanih temperaturah. Curie-jeva temperatura za keramični kristal je $T_c = 570^\circ\text{C}$, medtem ko ima svinčev cirkonijev titanat PZT ($\text{Pb}[\text{ZrTi}]\text{O}_3$) Curie-jevo temperaturo okrog 350°C . Pri ohlajanju kristal ponovno samodejno polarizira, vendar ne dobimo izrazite usmerjenosti dipolov, zato je treba tak pogonski element ponovno polarizirati.

2.2 Izvedbe upogibnih piezoizvršilnikov

Za krmiljenje pnevmatičnih ventilov je mogoče izbirati med več konstrukcijskimi različicami upogibnih piezopogonov. Najpogosteje sta to enostransko vpet trak ali obojestransko vpeta ploščica (sl. 9). Najpreprostejši upogibni izvršilniki so zgrajeni iz jeklenega traku, na katerega je nanesen (prilepljen) sloj piezomateriala. S priključitvijo električne napetosti se piezokeramični material podaljša, posledica pa je upogib oz. izbočitev nosilca oz. traku.

Upogibni dvoslojni piezoizvršilniki sestojijo iz dveh piezokeramičnih ploščic, ki sta vezani zaporedno oziroma vzporedno glede na smer polarizacije (sl. 10). Pri piezoizvršilniku z zaporedno vezavo električno napajanje deluje preko obeh plasti. Vzporedna vezava zahteva dovajanje napetosti na vsako plast ločeno, tako dvoplastni izvršilnik zahteva tri priključke, dva priključka na zunanji elektrodi in en priključek za vmesno plast, ki ločuje oba piezoelementa. Za enak raztezek oz. upogib izvršilnika v vzporedni vezavi je potrebna polovična električna napetost kakor pri zaporedni vezavi.

temperature applications. The Curie temperature for a ceramic crystal is $T_c = 570^\circ\text{C}$, while the lead-zirconium titanate PZT ($\text{Pb}[\text{ZrTi}]\text{O}_3$) has a Curie temperature around 350°C . During cooling down, the crystal is automatically re-polarized; however, the sense of direction of the dipoles is no longer clear, so that such an actuator has to be re-polarized.

2.2 Configurations of bending piezo-actuators

For the operation of pneumatic control valves it is possible to choose among several configurations of bending piezo-actuators. Most often these configurations involve either cantilever bending strips or plates fixed on both ends in a crossbow (Fig 9). The simplest bending actuators are built from a steel strip with a layer of piezo-material deposited (or glued) onto it. When the electrical power is switched on, the piezo-ceramic material extends and the result of this is the bending or deflection of the beam or strip.

A bending two-layer piezo-actuator consists of two piezo-ceramic plates in series or parallel connection with respect to the direction of polarization (Fig. 10). In the series connection the power supply acts across both layers, whereas in the parallel connection the power has to be supplied separately to each layer. Thus, a two-layer actuator requires three power supplies, two on the outer electrode and one for the middle layer, separating both piezo-elements. To reach the same actuator extension or deflection as in the series connection, the required voltage in the parallel connection is halved.

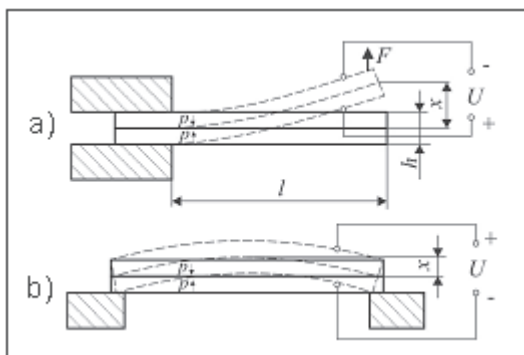

Sl. 9. Enostransko vpet piezoelement (a) in mostični piezoelement (b)
Fig. 9. Cantilever piezo-element (a) and crossbow piezo-element (b)

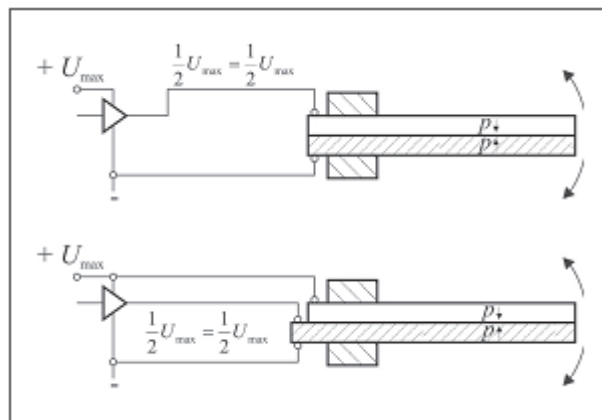

Sl. 10. Električno napajanje vzporedno in zaporedno vezanih piezoizvršilnikov
Fig. 10. Power supply in parallel and series connection

3 RAZVOJ PREDKRMILNEGA VENTILA S PIEZOELEMENTOM, ŠOBO IN ODBOJNO PLOŠČO

V okviru raziskave je bil razvit nov predkrmilni ventil, ki je bil prigraden na glavni pnevmatični ventil običajne izvedbe velikosti ISO 3. V predkrmilnem ventilu je bil uporabljen sistem, ki deluje po načelu šoba – odbojna plošča (sl. 11 a). Ventil sestavljata dve šobi – nespremenljiva šoba (kš) s premerom d_{ks} in nastavljiva šoba (nš) s premerom d_{ns} ter odbojna plošča (op), ki je oddaljena od nastavljive šobe za razdaljo h in pritrjena na mostični piezoelement. Izvršilnik napaja stisnjen zrak tlaka p_n , ki odteka skozi obe šobi v ozračje in tudi v krmilno komoro pnevmatičnega ventila. S približevanjem odbojne plošče se tlak p_k na izhodu počasi zvišuje, oz. pri oddaljevanju znižuje. Pri tem je bilo treba upoštevati, da mora piezoizvršilnik omogočati dotok zraka na eno stran potnega ventila in odzračitev druge strani (sl. 11 b) ter zagotoviti dovolj veliko silo tlaka za prekrmljenje glavnega ventila kakor tudi ustrezno frekvenco preklopov.

Za določitev najboljšega razmerja premerov obeh šob (d_{ks} in d_{ns}) je bilo treba analizirati delovanje predkrmilnega piezoventila. V ta namen je bilo postavljeno preizkuševališče ([12] in [13]) in izvedene meritve poteka tlaka p_k oz. posredno poteka preklapne sile glavnega ventila. Na temelju meritev sta bila določena potreben premik odbojne plošče h in potrebna sila F , ki jo mora zagotoviti piezoelement, da pride do popolnega odzračanja krmilne komore glavnega ventila na eni strani in vzpostavitev dovolj velike preklapne sile oz. tlaka

3 DEVELOPMENT OF A PILOT-STAGE PIEZO-ACTUATOR VALVE WITH A FLAPPER/NOZZLE SYSTEM

In the experimental part of our research, a new pilot-stage valve was developed and built into the main pneumatic valve of a standard configuration size, ISO 3. In the pilot-stage valve a system working on the nozzle/flapper principle was used, Fig 11. The valve consists of two nozzles: the constant nozzle (kš) with a diameter d_{ks} , and an adjustable nozzle (nš) with a diameter d_{ns} . There is also a flapper (op) distanced from the adjustable nozzle by a distance h and fixed to the crossbow piezo-element. The actuator is fed by compressed air with a pressure p_n , which flows out through both nozzles into the atmosphere, but also into the control chamber of the pneumatic valve. When the flapper is approaching the nozzle the pressure p_k at the outlet gradually increases and when the flapper is returning the pressure decreases. Here, it was necessary to consider that the piezo-actuator has to enable air inflow to one side of the directional valve and air relief on the other side (Fig 11) and provide a large enough pressure for piloting the main valve as well as a suitable switchover frequency.

To determine the optimal diameter ratio of both nozzles (d_{ks} / d_{ns}) it was necessary to analyze the operation of the pilot-stage piezo-actuators. For this purpose a test rig was set up ([12] and [13]) to measure and observe the histories of the pressure p_k and the switchover force of the main valve. The measurements provided a basis for the determination of the necessary flapper displacement, h , and the necessary force, F , that have to be provided by the piezo-element to achieve complete air relief in the control chamber of the main valve, on the one side, and a large enough switchover

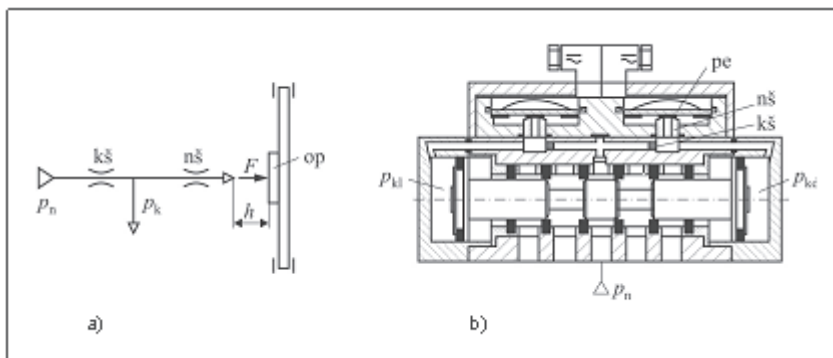

Sl. 11. Shematični prikaz sistema šoba - odbojna plošča (a) in glavni ventil s predkrmilnima piezoventiloma, ki delujeta po načelu šoba - odbojna plošča, v prerezu (b)

Fig. 11. a) Schematic of the nozzle-flapper system; b) the main valve with the pilot-stage piezo-actuators, flapper/nozzle design, cross section

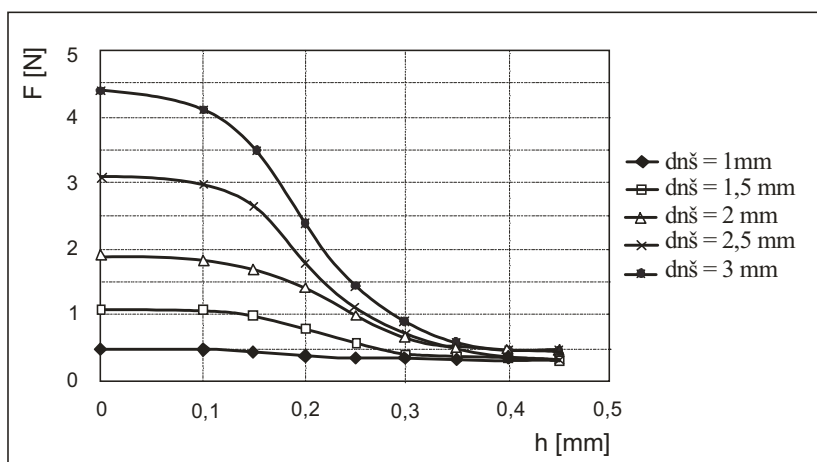

Sl. 12. Potek odvisnosti sile F od odmika odbojne plošče in premera nastavljive šobe
 Fig. 12. Force, F , versus flapper displacement for various adjustable nozzle diameters

v krmilni celici na drugi strani bata glavnega ventila. Na sliki 12 so prikazani rezultati meritev tlaka p_k oz. sile F v odvisnosti od odmika odbojne plošče h od nastavljive šobe pri različnih razmerjih premerov obeh šob (kš in nš).

Poteki sile F pri različnih premerih nastavljive šobe so značilni in kažejo odvisnost sile F od odmika odbojne plošče h . Rezultati kažejo, da se sila F prične zmanjševati pri odmiku odbojne plošče $h=0,1$ mm (sl. 12). Hitrost zmanjševanja sile se z večanjem premera šobe večja. Sila F se pri odmiku $h=0,4$ mm zmanjša na vrednost 0,5 N, neodvisno od premera nastavljive šobe. Iz tega je mogoče sklepati, da v krmilni celici ostaja še vedno tlak v vrednosti okrog 1 bar. Ugotovimo tudi, da je največja sila pri premeru nastavljive šobe 3 mm pod 4,5 N. Pri manjših premerih šob se sila tlaka na odbojno ploščo zmanjšuje.

Na potek preklapljanja ventila neposredno vplivata obe šobi v predkrmilnem ventilu ter odmik zaslonke h . Raziskava je pokazala, da na delovanje pnevmatičnega potnega ventila značilno vpliva razmerje med premerom nespremenljive šobe in premerom spremenljive šobe. Izpolnjen mora biti pogoj, da je $d_{kš} < d_{nš}$. Številne meritve so pokazale, da je za dani primer najugodnejše delovanje piezopremikala pri premeru $d_{kš} = 1,6$ mm in $d_{nš} = 2,5$ mm do $d_{nš} = 3$ mm ([12] in [13]).

Za določitev piezoelementa in njegovih značilk je treba opredeliti še razmere pri praznjenju in polnjenju krmilnih celic glavnega ventila v povezavi s premikom odbojne plošče h in sile F s katero deluje curek zraka pri iztoku iz $d_{nš}$ na mostični piezoelement.

force or pressure in the control chamber on the other side of the piston of the main valve. Fig 12 shows the measured results of the pressure, p_k , or force, F , versus the flapper displacement, h , from the adjustable nozzle at various diameter ratios of both nozzles (kš and nš).

The successive changes of the force, F , at various diameters of the adjustable nozzle are characteristic and show the dependence of force, F , on the flapper displacement, h . The results show that the force, F , starts falling at the flapper displacement $h = 0.1$ mm (Fig 12). The rate at which the force is falling increases with increasing nozzle diameter. At the displacement $h = 0.4$ mm, the force, F , falls to 0.5 N, irrespective of the diameter of the adjustable nozzle. From this we can conclude that in the control chamber there still remains a pressure of about 1 bar. It can also be seen that the maximum force at the adjustable nozzle diameter 3 mm is below 4.5 N. At smaller nozzle diameters the pressure acting on the flapper is falling.

The switchover of the valve is directly dependent on the sizes of both nozzles in the pilot-stage valve and the flapper displacement, h . Our research has shown that the operation of a pneumatic directional valve is largely influenced by the ratio between the constant nozzle diameter and the adjustable nozzle diameter. For a successful operation the condition $d_{kš} < d_{nš}$ has to be fulfilled. Numerous measurements have shown that for the studied case, the actuator operates best at a diameter $d_{kš} = 1,6$ mm and $d_{nš} = 2,5$ mm to $d_{nš} = 3$ mm ([12] in [13]).

To determine the piezo element characteristics, it is also necessary to measure the relationships between the supply and relief of the main chamber and the flapper displacement, h , and force, F , with which the air jet acts at the nozzle outlet ($dnš$) onto the crossbow piezo element.

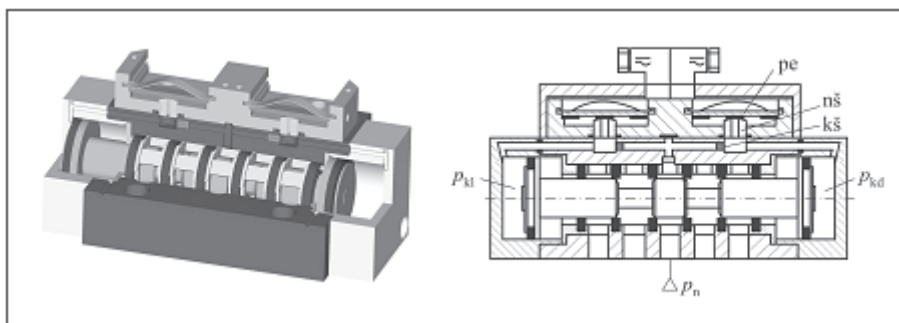

Sl. 13. Pnevmatični ventil ISO 3, 5/2 s predkrmilnim piezoventilom

Fig 13. Pneumatic valve ISO 3, 5/2 with a pilot-stage piezo-actuator.

Dana meritev je temelj za izbiro piezoelementa in določitev njegove najboljše delovne točke. Sila piezoelementa mora biti večja od sile tlaka. Temelj za izbiro piezoelementa sta tako potreben gib h oziroma deformacija piezoelementa in sila, ki jo mora piezoelement zagotavljati. Sklepiti je mogoče, da mora upogibni piezoelement omogočati gib med 0,1 in 0,4 mm in zagotavljati silo, večjo od 5 N, če želimo doseči zanesljivo delovanje ventila. Na podlagi rezultatov uvodne raziskave je bil izbran piezoelement [16] z največjim upogibom $\Delta x = 250 \mu\text{m}$, z največjo silo $F = 35 \text{ N}$ pri $U = 200 \text{ V}$ enosmerne napetosti.

Na sliki 13 je prikazan prirejen glavni potni ventil velikosti ISO 3, 5/2 s prigradenim predkrmilnim piezoventilom. Raziskava možnosti uporabe piezoizvršilnikov z upogibnimi elementi je pokazala, da je za krmiljenje 5/2 potnega ventila mogoče uporabiti na novo razviti predkrmilni ventil z upogibnim piezoelementom, ki deluje po načelu šoba - odbojna plošča. V predkrmilnem ventilu sta uporabljena dva mostična piezoelementa (sl. 3c, 9b in 13) ([16] in [17]). Vod napajalnega tlaka p_n je speljan iz glavnega napajalnega priključka glavnega potnega ventila. Napajalni zrak tako teče skozi nespremenljivo šobo do spremenljive šobe. V mirujoči legi sta oba piezoelementa neobremenjena, zrak teče iz obeh šob v ozračje. Pri vklopu enega izmed predkrmilnih ventilov se piezoizvršilnik upogne in se premakne proti šobi za premik h . Zaradi oviranja iztekanja zraka v krmilnem prostoru se tlak p_k zviša. Pri ustrezno veliki sili tlaka v krmilnem prostoru se ventil premakne v novo lego.

4 RAZULTATI MERITEV IN ANALIZA

4.1 Preizkuševališče

Za potrebe izvedbe meritev značilk ventila je bilo postavljeno preizkuševališče, kar je prikazano

This measurement serves as the basis for the selection of the piezo-element and the determination of its optimal operating point. The force of the piezo-element has to be greater than the force resulting from the pressure. The basis for the selection is thus the necessary displacement, h , or the deformation of the piezo-element and the force it has to ensure. It is possible to conclude that a bending piezo-element has to enable a deflection of between 0.1 to 0.4 mm and ensure a force greater than 5 N for reliable operation. On the basis of the results of our preliminary research, a piezo-element was selected with a maximum deflection of $\Delta x = 250 \mu\text{m}$, maximum force $F = 35 \text{ N}$ at $U = 200 \text{ V DC}$.

Fig 13 shows the main directional valve of size ISO 3, 5/2 with a pilot-stage piezo-actuator. The research into the possibilities of using piezo-actuators with bending elements has shown that for controlling a 5/2 directional valve it is possible to use the discussed crossbow piezo-element with a flapper/nozzle system. In the pilot-stage two such crossbow elements were used (Fig 3c, 9b and 13) ([16] in [17]). The supply pressure, p_n , is led from the main power supply on the main directional valve. The supply air flows through the constant nozzle to the adjustable nozzle. At standstill both piezo-elements are unloaded and the air flows from both nozzles into the atmosphere. When switching on one of the pilot-stage valves, the piezo-actuator bends and moves towards the nozzle by a displacement h . Due to greater blockage of the air outflow, the pressure, p_k , in the chamber rises. When the pressure in the chamber is big enough, the valve is switched over into a new position.

4 ANALYSIS OF MEASUREMENT RESULTS

4.1 Test rig

A test rig was set up to carry out the measurements of the valve's characteristics. A photograph of the rig is

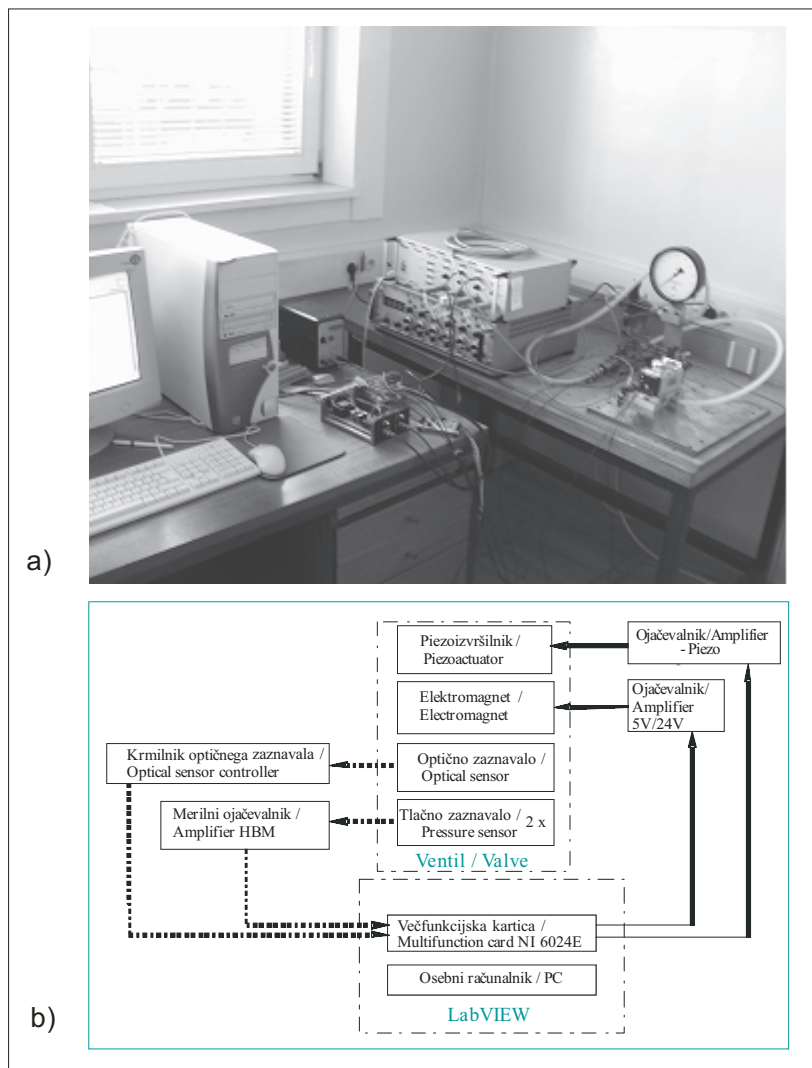

Sl. 14. a) Preizkuševališče, b) shema merilne verige

Fig. 14. a) A photograph of the test rig, b) block diagram of the measuring chain

na sliki 14a. Verižna shema merilne verige je prikazana na sliki 14b. Poteki tlakov v obeh celicah so bili merjeni s piezomerilniki tlakov ([13] in [14]), lega gibljivega dela glavnega ventila pa s svetlobnimi mejnimi stikali, ki omogočajo zaznavanje le končnih leg bata ventila, medtem ko vmesnih leg ni mogoče meriti. Potek preizkušanja je bil voden in rezultati so vrednoteni v okolju LabVIEW.

4.2 Analiza delovanja

Temelj za uspešen razvoj pnevmatičnega ventila s piezoventilom je potreben potek tlaka v obeh krmilnih celicah pri različnih premerih nespremenljive

shown in Fig 14a, while a block diagram of the measuring chain is presented in Fig. 14b. The histories of the pressures in both chambers were measured with piezo pressure gauges [13, 14], and the position of the moving part of the main valve with light limit switches, sensing only the final positions of the valve piston, while the intermediate positions could not be measured. The testing procedure was guided and the results evaluated in the LabVIEW environment.

4.2 Analysis of operation

The basis for the successful development of a pneumatic valve with a piezo-actuator is to be able to produce the required continuous changes of pres-

in spremenljive šobe pri napajalnem tlaku $p_n = 6$ bar. Rezultati meritev potekov tlakov pri običajnem elektromagnetnem ventilu so prikazani na sliki 15. Poteki tlakov so značilni in kažejo, da se v krmilni celici pri preklopu tlak p_{kL} na napajalni (tlačni) strani najprej hitro zviša, nato pa zniža in ob koncu preklopa ventila ponovno zviša na vrednost, ki je enaka napajalnemu tlaku. Sočasno se na drugi, odzračeni strani, tlak p_{kD} hitro zniža in ob koncu preklopa doseže vrednost pod $p_{kD} = 1$ bar, praktično $p_{kD} = 0$ bar. Iz diagrama je mogoče določiti tudi čas zakasnitve po vklopu predkrmilnega ventila, čas preklopa predkrmilnega ventila t_{pv} , čas preklopa glavnega ventila t_{gv} ter skupni čas preklopa t_p . Čas preklopa določa frekvenco ventila.

Na velikost potrebne sile za preklon in s tem krmilnega tlaka - p_{kL} , vplivajo masa gibljivega dela ventila m , sila trenja F_{tr} ter višina tlaka na nasprotni strani ventila p_{kD} . Gibljivi del ventila se premakne v novo lego, ko je sila tlaka na eni strani večja od vsote vseh sil, ki delujejo v nasprotni smeri gibanja.

Na sliki 16 so prikazani rezultati meritev tlakov v okolju LabVIEW za razviti ventil s predkrmilnim piezoventilom. Pri napajalnem tlaku $p_n = 5$ bar je potek značilen, v levi celici se tlak p_{kL} hitro zviša in nato zniža, ob koncu giba pa se ponovno zviša na največjo vrednost. Odzračitev nasprotno celice je hitra, vendar je vrednost tlaka v celici ob koncu giba bata ventila še vedno

sure in both chambers at different diameters of the constant and adjustable nozzles at the supply pressure $p_n = 6$ bar. The results of the measurements of pressure history in the standard electromagnetic valve are shown in Fig 15. The pressure histories are characteristic and show that on switchover in the control chamber the pressure, p_{kL} , on the supply side (pressure side) first rises steeply and then falls, and then at the end of the switchover rises again to a value equal to the supply pressure. Simultaneously, on the other air-relief side, the pressure, p_{kD} , falls and at the end of the switchover reaches a value below $p_{kD} = 1$ bar, practically $p_{kD} = 0$ bar. From the graph we can also determine the switchover time of the pilot-stage valve, t_{pv} , the switchover time of the main valve, t_{gv} , and total switchover time, t_p . This defines the frequency of the valve.

The magnitude of the force necessary for switching-over, i.e., the control pressure, p_{kL} , depends on the mass of the moving part of the valve, m , friction force, F_{tr} , and the pressure on the opposite side of the valve, p_{kD} . The moving part of the valve moves into a new position when the pressure force on one side is greater than the sum of all the forces acting in the opposite direction.

Fig. 16 shows the results of measurements of pressures in the LabVIEW environment for the developed pilot-stage piezo-actuator valve. At the supply pressure, $p_n = 5$ bar, the pressure changes are typical. In the left chamber the pressure, p_{kL} , rises steeply and then falls, and at the end of the stroke rises again to its maximum value. The air relief on the opposite side is fast; however, at the end of the piston stroke the value

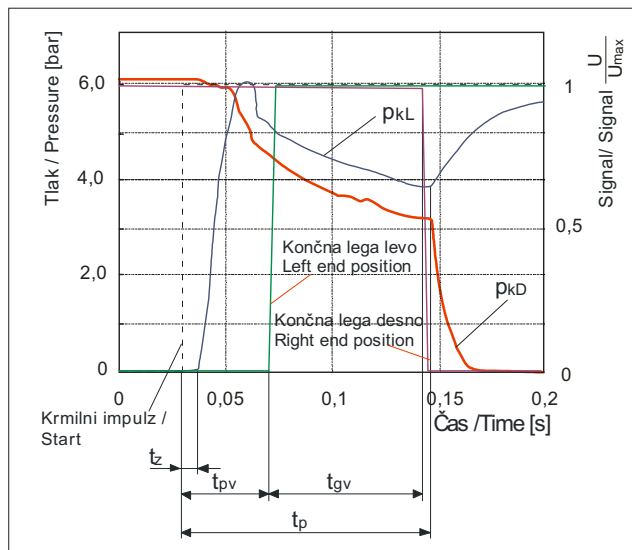

Sl. 15. Poteki tlakov in značilke preklopa ventila
 Fig. 15. Pressure histories and characteristics of valve switchover

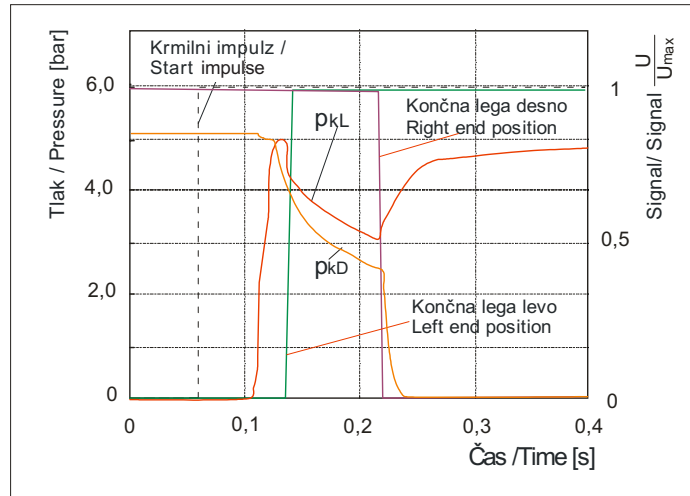

Sl. 16. Odvisnost posameznih časov od višine tlaka pri ventilu s piezopogonom
 Fig. 16. Characteristic times versus pressure values in a piezo-actuator valve

$p_{kD} = 2,5$ bar, kar dejansko zmanjšuje hitrost preklopa ventila.

Lastnosti ventila s piezopogonom in s sistemom šobe odbojne plošče je mogoče dobro ponazoriti z odvisnostjo časov preklopa - postavitve bata ventila iz začetne v končno lego in časov zakasnitve giba bata pri različnih napajalnih tlakih (sl. 17). Rezultati kažejo pričakovano povezavo med časi preklopa ventila in zakasnitve z višino napajalnega tlaka, vendar se je izkazalo, da višina napajalnega tlaka ne vpliva odločilno na čase preklopa ventila.

Mejno število preklapov prikazanega ventila je največje število gibov, ki jih gibljivi del ventila lahko opravi ob največji amplitudi, to pomeni, da se popolnoma premakne iz začetne v končno lego in nazaj. Za opazovani ventil s piezopogonom je mejna frekvenca 4,35 Hz in je

of the pressure in the chamber is still $p_{kD} = 2.5$ bar, which actually lowers the switchover rate.

The characteristics of a piezo-actuator valve with a nozzle-flapper system can be well illustrated by the relationship between the switchover times, i.e., the times necessary for the valve piston to get from the initial into its final position, the piston stroke delay times and the different supply pressures, Fig 17. The results display an expected relationship between the valve switchover times, the delay times and the supply pressure values; however, it was found that the supply pressure value does not significantly influence the valve switchover time.

The limiting number of switchovers of the developed piezo-valve represents the highest number of strokes that the moving part of the valve can perform at maximum amplitude, i.e., the fully completed motion from the initial into the final position and back. The piezo-drive valve under observation had a limit frequency of

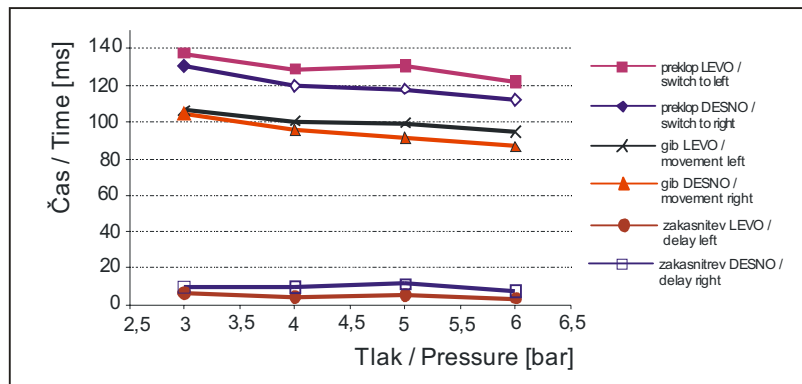

Sl. 17. Odvisnost posameznih značilnih časov ventila pri različnih napajalnih tlakih
 Fig 17. Characteristic times of the valve versus supply-pressure values

bila določena iz odziva ventila na vhodni pravokotni signal. Seveda na mejno frekvenco poleg pogonskega dela vplivata še masa gibljivega dela ventila, trenje med gibljivimi in negibljivimi deli ventila ter pretočne in tlačne sile v ventilu.

5 SKLEP

Razvoj pnevmatičnih komponent v svetu terja nenehno optimiranje sedanjih in tudi razvoj novih komponent. Eno izmed možnosti razvoja novih ventilov in optimiranja sedanjih je vsekakor uporaba drugačnih, predvsem piezoizvršilnikov za krmiljenje ventilov.

Na podlagi teoretičnih izhodišč in meritev pnevmatičnega ventila je mogoče sklepati, da uporaba upogibnih piezoelementov v predkrmilnih potnih ventilih ponuja vrsto prednosti pred elektromagnetnimi izvršilniki. Poleg konzolnih upogibnih izvršilnikov je mogoče uporabiti za preklapljanje ventila tudi mostično izvedbo v sistemu šoba odbojna plošča, kar je bilo izvedeno tudi v tej raziskavi.

Razviti predkrmilni izvršilnik je prigraden k običajnemu potnemu ventilu velikosti ISO 3, 5/2, kar omogoča tudi primerjave med elektromagnetnim in piezoizvršilnikom. Meritve so pokazale, da ima prototipna izvedba ventila preklapne frekvence v mejah, kakršne imajo primerjalni elektromagnetni ventili.

Mejne frekvence so dovolj velike tudi za hitre delovne kroge. Ustrezne konstrukcijske rešitve in integracija napajalne elektronike bo v nadaljevanju omogočila gradnjo manjših in hitrejših ventilov.

4.35 Hz, which was determined from the valve response to the rectangular signal. It is, of course, understood that, apart from the driving part, the limit frequency is influenced by the mass of the moving part of the valve, the friction between the moving and inert parts of the valve, the flow force and the pressure in the valve.

5 CONCLUSION

Trends in the development of fluid power systems dictate continuous efforts to optimise the existing components and develop new ones. One of the possible developments in this area is the use of alternative piezo-actuators for piloting valves.

On the basis of a theoretical study and experimental measurements it is possible to conclude that the use of bending piezo elements in the pilot-stage of directional valves offers a number of advantages over electromagnetic actuators. Besides the cantilever configuration, also the crossbow flapper nozzle design can be successfully used, which was also realized in this research.

The developed pilot-stage actuator is a unit built to the standard directional valve ISO 3 5/2, offering a comparison between the electromagnetic and piezo-actuators. The measurements have shown that the prototype design has switchover frequencies ranging within the limits that are also characteristic for electromagnetic valves.

The limit frequencies are high enough to allow for rapid working cycles. In future, better design solutions and the integration of power-supply electronics will enable smaller valve sizes and faster operation.

6 LITERATURA

6 REFERENCES

- [1] Herakovič N., Noe D. (1998) Nova generacija energetske varčnih pnevmatičnih ventilov. *Ventil*, letnik 4, št. 4, str. 210-214.
- [2] O+P-Gesprächsrunde (2002) Aktoren für Ventile und ihre Peripherie, *O+P Ölhydraulik und Pneumatik*, 46(2002) Nr. 11-12, Str. 640-689
- [3] Herakovič N. (1999) Die Untersuchung des Nutzung des Piezoeffektes zur Ansteuerung fluidtechnischer Ventile, *Verlag Meinz*, Aachen.
- [4] Matten N., Ohmenhäuser M. (1994) Stetigwirkendes Wegeventil mit piezoaktuatorischem Stellelement. *Ölhydraulik und Pneumatik*, Vol. 38, Nr. 6, Seite 350-355.
- [5] Herakovič N. (1995) Piezoaktorbetätigung für ein einstufiges hochdynamisches Servoventil. *Ölhydraulik und Pneumatik*, Vol. 39, Nr. 8, Seite 601-605.
- [6] Murenhoff H. (2003) Trends in Ventilentwicklung, *O+P Ölhydraulik und Pneumatik*, Nr. 47 (2003), Str. 226-241.

- [7] Wennmacher G., Yamada H. (1993) Prototyp eines dynamischen Schnellschaltventils mit piezoelektrischer Ansteuerung. *Ölhydraulik und Pneumatik*, Vol. 37, Nr. 10, Seite 794-797.
- [8] N.N. Physik Instrumente (PI) Katalog.
- [9] N.N. Piezooxide (PXE), Eigenschaften und Anwendungen, Valvo, Philips 1.Auflage, Juli 1988.
- [10] Loesel M. (2003) Klein- und Versteuerventile, Steuerung neutraler und aggressiver Fluide, *O+P Ölhydraulik und Pneumatik*, 47 (2003) Nr. 5, Str. 360-362.
- [11] <http://users.telenet.be/educyclopedia/electronics/sensorspiezo.htm>
- [12] Kezele N. (2001) Določitev karakteristik pnevmatičnih potnih ventilov. Diplomaska naloga, *Fakulteta za strojništvo, Univerza v Ljubljani*, Ljubljana.
- [13] Slamnik G. (2002) Razvoj krmiljenja pnevmatičnega ventila s piezoaktuatorjem. Diplomaska naloga, *Fakulteta za strojništvo, Univerza v Ljubljani*, Ljubljana.
- [14] Fabjan R. (2003) Določitev dinamičnih karakteristik pnevmatičnih potnih ventilov. Diplomaska naloga, *Fakulteta za strojništvo, Univerza v Ljubljani*, Ljubljana.
- [15] www.face-int.com/pdf/whtpaper.pdf
- [16] Podatki podjetja Ceramtec
- [17] Katalog podjetja TIO
- [18] Hoerbiger katalog

Naslov avtorjev: doc. dr. Niko Herakovič
prof. dr. Dragica Noe
Univerza v Ljubljani
Fakulteta za strojništvo
Aškerčeva 6
1000 Ljubljana
niko.herakovic@fs.uni-lj.si
dragica.noe@fs.uni-lj.si

Authors' Address: Doc. Dr. Niko Herakovič
Prof. Dr. Dragica Noe
University of Ljubljana
Faculty of Mechanical Eng.
Aškerčeva 6
1000 Ljubljana, Slovenia
niko.herakovic@fs.uni-lj.si
dragica.noe@fs.uni-lj.si

Prejeto:
Received: 7.3.2006

Sprejeto:
Accepted: 22.6.2006

Odprto za diskusijo: 1 leto
Open for discussion: 1 year